**Structural timber — Visual strength
grading — Basic principles**

*Bois de structure — Classification visuelle selon la résistance —
Principes de base*



Reference number
ISO 9709:2005(E)

© ISO 2005

PDF disclaimer

This PDF file may contain embedded typefaces. In accordance with Adobe's licensing policy, this file may be printed or viewed but shall not be edited unless the typefaces which are embedded are licensed to and installed on the computer performing the editing. In downloading this file, parties accept therein the responsibility of not infringing Adobe's licensing policy. The ISO Central Secretariat accepts no liability in this area.

Adobe is a trademark of Adobe Systems Incorporated.

Details of the software products used to create this PDF file can be found in the General Info relative to the file; the PDF-creation parameters were optimized for printing. Every care has been taken to ensure that the file is suitable for use by ISO member bodies. In the unlikely event that a problem relating to it is found, please inform the Central Secretariat at the address given below.

© ISO 2005

All rights reserved. Unless otherwise specified, no part of this publication may be reproduced or utilized in any form or by any means, electronic or mechanical, including photocopying and microfilm, without permission in writing from either ISO at the address below or ISO's member body in the country of the requester.

ISO copyright office
Case postale 56 • CH-1211 Geneva 20
Tel. + 41 22 749 01 11
Fax + 41 22 749 09 47
E-mail copyright@iso.org
Web www.iso.org

Published in Switzerland

Contents

Page

Foreword.....	iv
Introduction	v
1 Scope	1
2 Normative references	1
3 Terms and definitions.....	1
4 Symbols and abbreviated terms	1
5 General.....	1
5.1 Visual strength-graded timber.....	1
5.2 Visual strength-grading operations	1
5.3 Visual strength-grading principles of quality control	2
6 Resource and sawn timber input requirements	2
6.1 General.....	2
6.2 Input requirements	2
6.3 Control of inputs	3
6.4 Reprocessing of previously graded material.....	3
7 Visual strength-grading requirements.....	3
7.1 Grader requirements	3
7.2 Grading process	3
7.3 Check on visual grading process	4
8 Visual graded timber structural properties	4
8.1 General.....	4
8.2 Initial evaluation	4
8.3 Periodic evaluation	5
9 Product identification	5
10 Documentation	5
Annex A (informative) Example of a visual strength-grading timber standard — based on the need for design values where a high degree of certainty of structural properties is required	6
Annex B (informative) Example of a visual strength-grading timber standard — based on the need for design values where a high degree of certainty of structural properties is <i>not</i> required.....	19
Bibliography	25

Foreword

ISO (the International Organization for Standardization) is a worldwide federation of national standards bodies (ISO member bodies). The work of preparing International Standards is normally carried out through ISO technical committees. Each member body interested in a subject for which a technical committee has been established has the right to be represented on that committee. International organizations, governmental and non-governmental, in liaison with ISO, also take part in the work. ISO collaborates closely with the International Electrotechnical Commission (IEC) on all matters of electrotechnical standardization.

International Standards are drafted in accordance with the rules given in the ISO/IEC Directives, Part 2.

The main task of technical committees is to prepare International Standards. Draft International Standards adopted by the technical committees are circulated to the member bodies for voting. Publication as an International Standard requires approval by at least 75 % of the member bodies casting a vote.

ISO 9709 was prepared by Technical Committee ISO/TC 165, *Timber structures*.

Introduction

The general principle of this International Standard is that any type of visual strength-grading procedure is acceptable, provided it is defined, controlled, and documented to the extent required to reflect the degree of certainty of structural properties intended for the structural application of the product. The body of this International Standard specifies the essential features common to all visual strength-grading operations. The requirements are minimal so as to ensure maximum scope and flexibility in the application of a standard applied to the visual strength-grading process as applied to timber. The annexes provide a detailed example of a conformance standard resulting in strength properties having a high degree of engineering reliability and a simple to apply standard resulting in strength properties where a high degree of engineering reliability is not required.

This International Standard was based initially on the European Standard EN 518, *Structural timber — Grading — Requirements for visual strength-grading standards* and modified to bring it into conformance with ISO procedures and requirements.

The bibliography lists a number of additional standards referenced during the development of this International Standard.

.....

Structural timber — Visual strength grading — Basic principles

1 Scope

This International Standard establishes the basic principles for rules and procedures governing the visual sorting of timber for use in structural applications.

2 Normative references

The following referenced documents are indispensable for the application of this document. For dated references, only the edition cited applies. For undated references, the latest edition of the referenced document (including any amendments) applies.

ISO 13910, *Structural timber — Characteristic values of strength-graded timber — Sampling, full-size testing and evaluation*

3 Terms and definitions

For the purposes of this document, the terms and definitions given in ISO 13910, and in Annexes A and B apply. The terms and definitions given in Annexes A and B are representative of those in rules and procedures governing the visual sorting of timber for use in structural applications.

4 Symbols and abbreviated terms

For the purposes of this document, the symbols and abbreviated terms given in ISO 13910 and in Annex A apply. The symbols and abbreviated terms given in Annex A are representative of those in rules and procedures governing the visual sorting of timber for use in structural applications.

5 General

5.1 Visual strength-graded timber

Visual strength-graded timber is sawn wood that has been sorted into structural or non-structural grades according to visual criteria. The visual criteria identify physical features that may affect timber strength.

5.2 Visual strength-grading operations

A typical visual strength-grading operation shall be comprised of a visual grader who sorts an input resource into one or more output grades (see Figure 1). Some of the timber may not meet the requirements of the minimum specified grade.

In addition to the structural requirements, nonstructural or utility requirements may also be specified.

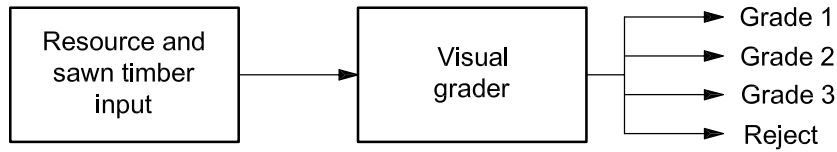

Figure 1 — Schematic of visual strength-grading operation

5.3 Visual strength-grading principles of quality control

Visual grading is one element of quality control operations. This International Standard requires that the quality control related to the visual grading operation is undertaken by placing checks on the three components of the grading operation: 1) the resource and sawn timber inputs; 2) the visual sorting process; and 3) the graded timber output (see Figure 1).

NOTE In theory it is possible to control quality either

- a) by control on the resource input and the visual sorting operation, or
- b) by checks of the visual sorting operation and of the quality of the output grades.

However, in practice it is not feasible to rely solely on the checks on the output grades because of the high variability and complexity of timber, and because of the large sample sizes that may be required to reliably measure the 5-percentile strength values.

6 Resource and sawn timber input requirements

6.1 General

The input resources shall be identified in terms of all parameters that may affect the output of the visual grade sorting operation.

6.2 Input requirements

6.2.1 Resource

The parameter that shall be identified is the timber species or mixture of species.

Other parameters that may be identified are

- a) silvicultural practices used,
- b) log source,
- c) log size,
- d) cutting pattern used to manufacture sawn timber from logs, and
- e) any other parameters deemed to be important.

6.2.2 Sawn timber

Parameters that shall be specified are

- a) condition (such as seasoned, unseasoned, etc.),

- b) moisture content and moisture content range, and
- c) any other parameters deemed to be important.

6.3 Control of inputs

A periodic check on the resource and sawn timber inputs should be defined and specified.

6.4 Reprocessing of previously graded material

If major reprocessing of previously graded material is permitted, then any requirements for re-grading of the material should be specified.

7 Visual strength-grading requirements

7.1 Grader requirements

The grader shall be qualified to grade timber accurately at the necessary operational speeds and to evaluate the visual quality of all grades and sizes that the grader will encounter in commercial visual grading operations.

7.2 Grading process

7.2.1 General

The grading process shall be specified. During grading, methods shall be in place to ensure that the timber species and the timber moisture content comply with the requirements specified.

The detail required in the standard is directly related to the reliability of the stated/claimed structural properties.

- Annex A, an informative annex, provides a detailed example of a conformance standard resulting in strength properties having a high degree of engineering reliability.
- Annex B, an informative annex, provides an example of a conformance standard resulting in strength properties where a high degree of engineering reliability is not required.

7.2.2 Rules to satisfy the structural requirements

To ensure adequate structural properties, limitations shall be specified on one or more of the following features:

- a) knots (type, size and location);
- b) slope of grain;
- c) rate of growth;
- d) fissures (shake, checks, and/or splits);
- e) moisture condition; and
- f) any other features that are deemed to be important.

7.2.3 Rules to satisfy the utility requirements

To ensure adequate visual quality, limitations may be specified on one or more of the following features:

- a) crookedness;
- b) dimensions and tolerances;
- c) fungal decay;
- d) insect damage;
- e) sapstain;
- f) squareness;
- g) white speck; and
- h) any other features that are deemed to be important.

7.3 Check on visual grading process

A periodic check shall be required to assess the accuracy of the grading process. If a check indicates that the process is inadequate, then appropriate measures may be specified to modify the process so that the process is adequate.

8 Visual graded timber structural properties

8.1 General

The critical properties of strength-graded timber are structural properties. These structural properties may be incorporated in the visual strength-grading standard or may be in other appropriate standards referencing the grades determined using the criteria of the visual strength-grading standard. These properties shall be as defined and measured as specified in the test methods in ISO 13910.

The structural design properties shall be determined from tests on timber having a defined moisture content, if the tests are conducted on timber having a moisture content that differs from that specified by the procedure conforming to this International Standard, the properties resulting from the tests shall be adjusted (using sound engineering principles) so that the structural design properties reflect the intent of these basic requirements and/or the applicable associated design codes.

8.2 Initial evaluation

Once the grading operation has been selected, evidence shall be provided that the resultant output grades have the structural properties stated for the material. This evidence may be linked to other mills carrying out equivalent sorting procedures.

For cases where such evidence is not available or it is not appropriate to link the evidence to other mills, an initial test program should be specified. The requirements for this test program should be based on sound sampling principles and the tests for the structural properties shall be based on the test procedures specified in 8.1.

For cases where a high degree of certainty of the structural properties is not required, then the structural properties of the material may be based on other mechanical or physical properties representative of the grade being evaluated providing these properties have been defined and related to the test procedures as specified in 8.1 and continue to be used as the basis of the sorting process.

8.3 Periodic evaluation

Direct measurement of the structural properties of full-size timber shall be undertaken if there is a reason to expect that the structural properties of visually graded lumber have changed and may also be specified to be undertaken at periodic specified intervals.

9 Product identification

A product identification mark on the timber shall be specified to indicate the document conforming to this International Standard on which the sorting is based, the grade and/or strength class, and the producer responsible. The product identification mark may also include other information deemed important.

Each piece of timber shall be marked except for high quality strength-graded timber intended for structural as well as appearance purposes. For this high quality appearance timber, each shipment shall be accompanied by documentation containing the product identification requirements specified in the standard.

10 Documentation

Documentation requirements shall include:

- a) the standard on which the visual strength-grading process is based;
- b) specifications of the resource input;
- c) specifications of the visual grade sorting process;
- d) specifications for the timber grade criteria;
- e) methods for assigning and confirming a grade; and
- f) specifications for the identification of the product.

Documentation requirements may include:

- g) specifications and control checks of the resource input;
- h) specifications and control checks of the visual grade sorting process;
- i) specifications and control checks of the structural properties;
- j) materials identifying the allocation of responsibilities for quality control operations; and
- k) other specifications or materials deemed to be important.

Annex A (informative)

Example of a visual strength-grading timber standard — based on the need for design values where a high degree of certainty of structural properties is required

This is one of a number of possible systems provided as an example only - not a system proposed for universal usage. This example is a practical implementation of the visual strength-grading principles defined in the main body of ISO 9709, as applied to the following case:

- rectangular timber;
- for structural applications;
- requiring strength characteristic values within 5 % of the expected values.

The layout corresponds to that of an International Standard (not a normal Annex) to clearly show how an International Standard in this domain should look. It includes both

- normative elements (Scope, Normative references, Terms and definitions, Symbols and abbreviated terms, Requirements, Sampling, Test methods), and
- supplementary informative elements (Bibliography).

Informative annexes (like this Annex A) and normative annexes may also form part of an International Standard.

NOTE The Scope does not usually form part of an annex, but is included in this example for completeness purposes.

A.1 Scope

This standard provides an example of the grading procedures for producing visually sorted strength and stiffness graded rectangular timber for structural applications requiring strength characteristic values within 5 % of the expected values.

It is applicable for timber that is graded in the seasoned state.

It may be applicable for timber that is graded in the unseasoned state providing the structural design properties for the timber are modified to reflect the intent of this standard and/or to the associated design codes.

A.2 Normative references

The following referenced documents are indispensable for the application of this document. For dated references, only the edition cited applies. For undated references, the latest edition of the referenced document (including any amendments) applies.

ISO 9709, *Structural timber — Visual strength grading — Basic principles*

ISO 13910, *Structural timber — Characteristic values of strength-graded timber — Sampling, full-size testing and evaluation*

A.3 Terms and definitions

For the purposes of this document, the following terms and definitions apply.

A.3.1

compression wood

abnormal wood that forms on the underside of leaning and crooked coniferous trees

A.3.2

fungal decay

not sapstain but wood that has been damaged by fungal attack

A.3.3

grade

population of timber derived from a specified resource and by applying a specified sorting procedure

A.3.4

insect damage

damage that has been caused by insects

A.3.5

knot area ratio

KAR

ratio of the sum of the cross-sectional knots to the cross-sectional area of a piece of timber

A.3.6

knot

portion of a branch or limb that has become incorporated into a piece of timber. In timber, knots are classified as to form, size, quality, and occurrence

A.3.7

margin knot area ratio

MKAR

ratio of the projected cross-sectional area of all knots intersected by the margin areas of the piece

A.3.8

pith

small soft core in the structural centre of a log

A.3.9

pocket

well defined opening between the rings of annual growth which develops during the growth of the tree and typically contains resin or bark

A.3.10

sapstain

natural variation from the colour of the sapwood

A.3.11

seasoned timber or dry timber

timber with an average moisture content of 15 % or less at the time of grading

A.3.12

structural requirements

grade requirements that affect the structural properties of the timber. Structural features are: knots, slope of grain, fissures, and any other features that may cause a decrease in strength properties to an amount which threatens the serviceability of the piece

A.3.13

thickness

lesser dimension perpendicular to the longitudinal axis of a piece of timber

A.3.14

total knot area ratio

TKAR

ratio of the projected cross-sectional areas of all knots intersected by the total cross-sectional area of the piece

A.3.15

unseasoned timber

timber with moisture content greater than 20 % at the time of grading

A.3.16

utility requirements

grade requirements that do not affect the structural properties of the timber and/or to an amount which threatens the serviceability of the piece

A.3.17

visual graded timber

sawn wood that has been sorted into structural or non-structural grades according to visual criteria. The visual criteria identify visible physical features that affect timber strength, utility of the product and/or the visual quality of the product

A.3.18

white speck

white or brown pit or spot in wood caused by the "Fomes Pini" fungus that only develops in the living tree and does not develop further in service

A.3.19

width

greater dimension perpendicular to the longitudinal axis of a piece of timber

Other features such as bow, cup, fissures, knots, rate of growth, slope of grain, spring, twist and wane should be defined in the appropriate subclauses and by referencing the features to an illustration.

A.4 Symbols and abbreviated terms

A.4.1 General notation

E modulus of elasticity

f strength

N sample size

CV coefficient of variation

A.4.2 Subscripts

0,05 5-percentile

data value measured on data sample

mean mean value

m bending

target target or specified value for the grade

A.5 General

A.5.1 Visual strength-grading operations

The visual strength-grading operation shall be comprised of one or more visual graders who sort an input resource into two output grades. Some of the timber may not meet the requirements of the minimum grade.

Structural and utility requirements are specified for the visual strength-graded timber.

A.5.2 Principles of quality control

The visual strength grading is one element of the quality control operations. This standard requires that the quality control be undertaken by placing checks on the three components of the strength-grading operation: the resource input, the visual grade sorting, and the graded timber output.

A.6 Resource input requirements

The input resource shall be defined in terms of all parameters that may affect the output of the visual grade sorting operation.

Parameters that shall be defined are

- a) timber species or mixture of species,
- b) log source,
- c) log size,
- d) silvicultural practices used,
- e) cutting pattern used to manufacture sawn timber from logs,
- f) seasoning condition at the time of visual grade sorting, and
- g) moisture content.

Limits on resource parameters shall be stated in a quality manual.

If major reprocessing of previously graded material is undertaken that may reduce the structural design properties or lower the visual grade, then the material shall be re-graded.

A.7 Visual properties

A.7.1 Grader requirements

The grader shall be qualified to grade timber to the requirements of this standard at the necessary operational speeds and to evaluate the visual quality and sizes being manufactured.

A.7.2 Visual grading requirements

A.7.2.1 Definitions of features

In addition to the features defined in A.3, the size of a knot is assessed by the knot area ratio (KAR) (see A.3.5 and Figure A.1). In addition, the location of a knot is defined in terms of edge, face and margin areas (see Figure A.2).

Two types of knot area ratios are defined:

- the margin knot area ratio (MKAR) (see A.3.7); and
- the total knot area ratio (TKAR) (see A.3.14).

Fissures are measured as illustrated in Figure A.3.

The slope of grain (see Figure A.4) is assessed over a distance sufficiently great so as to avoid the influence of local deviations.

To assess rate of growth, measurements are made on one end of the piece, and expressed as the average ring width in millimetres along a straight line 75 mm long normal to the growth rings, passing through the centre of the end of the pieces [see Figure A.5 a)]; or commencing 25 mm from the pith when it is present [see Figure A.5 b)]. When a line 75 mm in length is unobtainable, the measurements are to be made on the longest possible line normal to the growth rings and passing through the centre of the piece.

A.7.2.2 Limits for structural features

The following limitations shall be applied so as to meet the visual grade structural requirements.

Table A.1 provides the limits for ensuring adequate structural properties. Two visual strength grades, denoted by G1 and G2, are specified. To qualify for a grade, a piece shall not contain characteristics which exceed the limits given in Table A.1.

Sapstain is not a structural defect and shall be acceptable without limitation.

Any piece which contains defects such as compression wood, insect damage, fungal decay (not sapstain), physical damage, combinations of knots and/or other characteristics, which can cause a decrease in strength properties to an amount which threatens the serviceability of the piece, shall be excluded from the grades.

It shall be permissible for pieces to be accepted, where the reduction in strength caused by the abnormal defect or damage is obviously less than that caused by the defects admitted by the grade, subject to the provision that these abnormal defects are of a type which will not progress after conversion and drying, e.g. white speck derived from the standing tree.

Table A.1 — Grade limits for ensuring structural properties for G1 and G2 grades

Feature	Feature limit	
	Grade G1	Grade G2
Limitation on knot sizes	Either MKAR > 1/2 TKAR ≤ 1/2 or MKAR ≤ 1/2 TKAR ≤ 1/2	Either MKAR ≤ 1/2 TKAR ≤ 1/3 or MKAR > 1/2 TKAR ≤ 1/4
Slope of grain	1 in 6	1 in 10
Average width of annual rings (rate of growth)	≤ 10 mm	≤ 6 mm
Fissures — not through thickness — through thickness	unlimited ≤ 600 mm	L/2 2b
Pockets (resin pockets and bark pockets)	Unlimited if shorter than half width of piece, otherwise same limits as for size of fissures	
NOTE		
L is the length of piece		
b is the width of piece		
TKAR is the total knot area ratio		
MKAR is the margin knot area ratio		

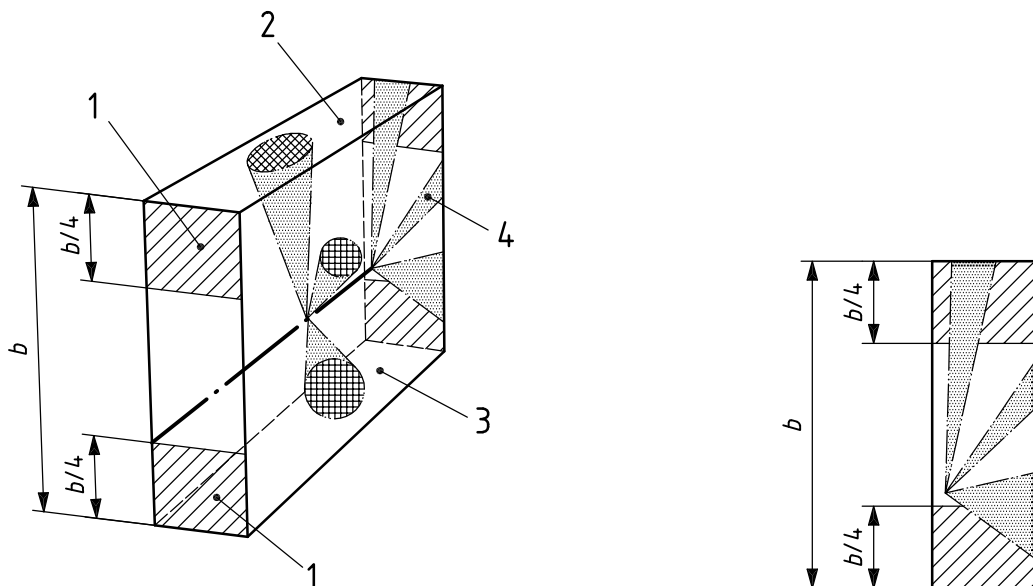

a) Axonometric view, showing a group of knots and their projection on a cross-section plane

b) Front view of projection plane showing projection of knots

Key

- 1 margin
- 2 edge
- 3 face
- 4 plane of projection

Figure A.1 — Illustration of knot projection area

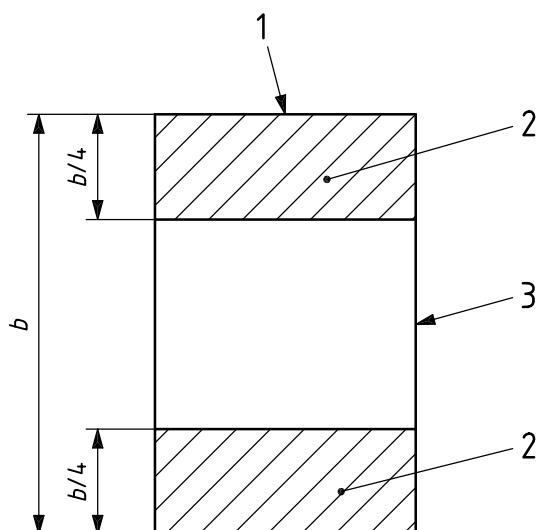

Key

- 1 edge
- 2 margin area
- 3 face

Figure A.2 — Illustration of edge, face and margin areas

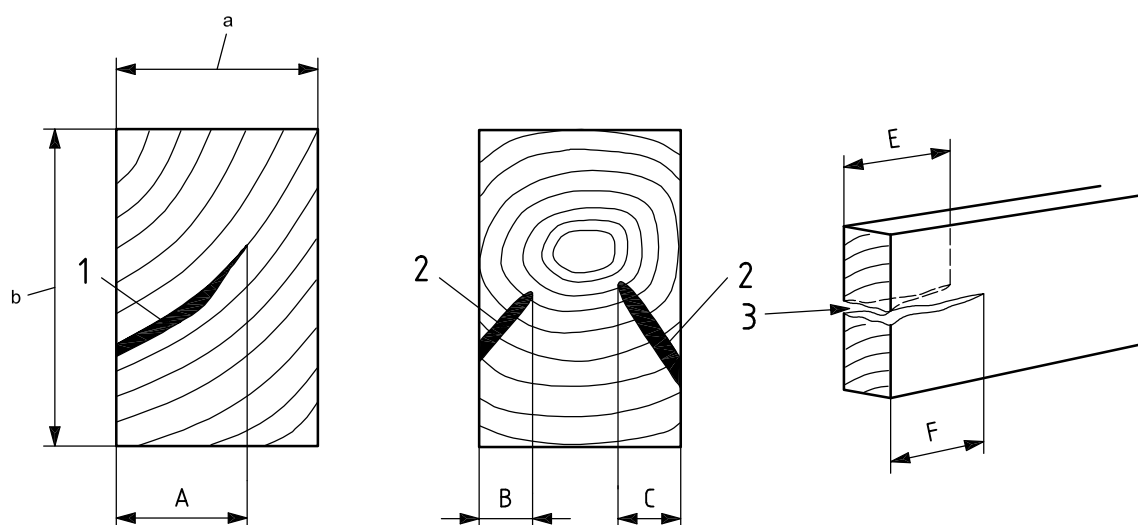

Key

- 1 shake The length of the shake is A
- 2 check The length of the check is B + C
- 3 split The length of the split is $(E + F)/2$

- a Thickness.
- b Width.

Figure A.3 — Measurement of fissure

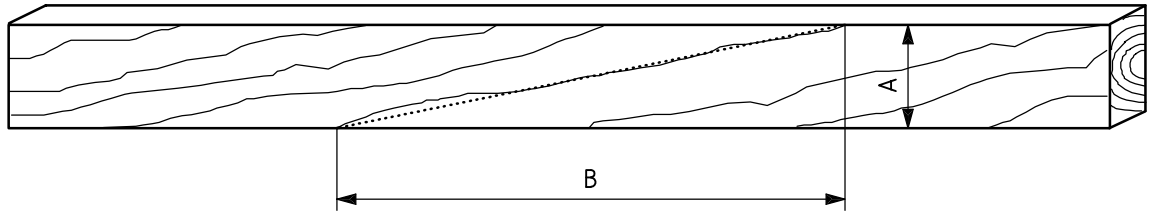

Key

- 1 slope of grain is A/B

Figure A.4 — Measurement of slope of grain

Dimensions in millimètres

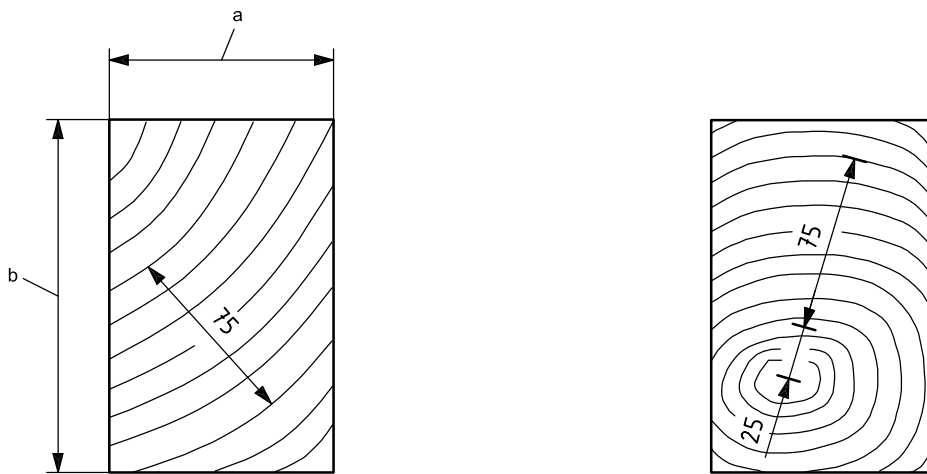

a) Average ring width measurement, passing through the centre of the end of the piece

b) Average ring width measurement, commencing 25 mm from the pith when this is present

Key

- a Thickness.
b Width.

Figure A.5 — Measurement of rate of growth

A.7.2.3 Limits for utility features

The following limitations shall be applied to meet the visual grade utility requirements:

- | | |
|-----------------------------|--|
| a) knot on wide face | 1/2 width; |
| b) thickness and width | 0 mm to +2 mm; |
| c) squareness | ± 2 degrees; |
| d) wane (see Figure A.6) | 1/3 of width of either face; |
| e) bow (see Figure A.7) | 5 mm per meter of length; |
| f) spring (see Figure A.7) | 4 mm per metre of length; |
| g) twist (see Figure A.7) | 1 mm per 25 mm of width per metre of length; and |
| h) cupping (see Figure A.8) | 1 mm per 50 mm of width. |

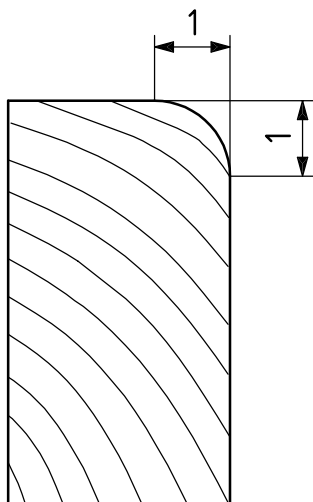

Key

- 1 wane

Figure A.6 — Measurement of wane

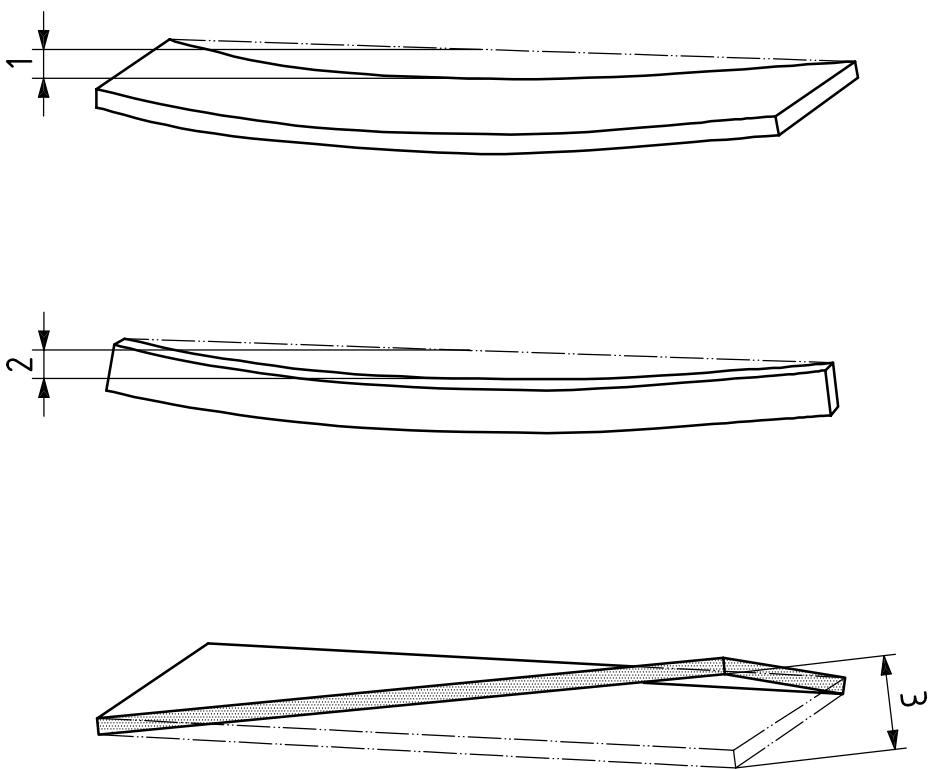

Key

- 1 bow
- 2 spring
- 3 twist

Figure A.7 — Measurement of bow, spring, and twist

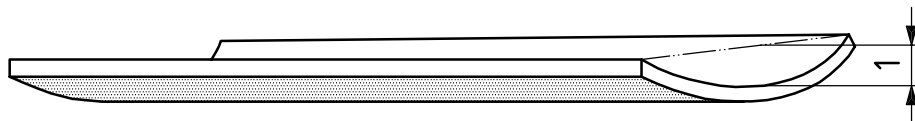
**Key**

- 1 cupping

Figure A.8 — Measurement of cupping

A.7.3 Check on visual grading process

During each production shift a check shall be made to assess the accuracy of the grading process. This shall be done by regrading a sample of graded timber. The pass criterion is that not more than 5 % of the pieces fall below grade and that not more than 20 % of the pieces fail the utility limitations.

If the checks indicate that the process is inadequate, then appropriate measures shall be undertaken to modify the process.

A.8 Structural properties

A.8.1 General

The critical properties of visual strength-graded timber are structural properties. These properties are defined and measured as specified in ISO 13910.

NOTE ISO 9709 principles identify that the structural properties may be incorporated in the visual strength-grading standard or may be in other appropriate standards referencing the grades determined using the criteria of the visual strength-grading standard. This Annex A example standard incorporates structural properties in its grade criteria.

A.8.2 Initial evaluation

Once the visual grading operation has been selected, evidence shall be provided that the resultant output grades have the required structural properties. This evidence shall be through direct measurement of structural properties of full-size timber (see A.8.1) or through the equivalent data from other equivalent grading operations.

Initial evaluation procedures by case are given below.

- a) For the case where a strength-grading operation in a mill commences with a grade-sorting procedure and input resource that are equivalent to those already existing in other mills, no special initial evaluation is required as the evaluation data obtained from the other mills may be cited as initial evidence of properties of the graded timber.
- b) For the case where an existing grade-sorting procedure is applied to a new species and/or a new mixture of species, then measurements of the graded material shall be made at least for bending and tension strength and modulus of elasticity.
 - 1) All grades and at least two sizes spanning the range of commercial material to be produced should be evaluated.
 - 2) Other structural properties may be deduced from relationships observed in other similar species or mixtures of species.

- c) For the case of a new grade-sorting procedure, all specified grade properties and all grades shall be assessed.
- 1) For material having a limited range of sizes, then all sizes shall be evaluated.
 - 2) For material having three or more widths and/or two or more thicknesses, then it shall be sufficient to limit the evaluation to three widths and two thicknesses providing the widths and thicknesses evaluated are representative of the overall range of sizes available.

A.8.3 Periodic evaluation

If there is a reason to expect that the structural properties of visual graded lumber have changed or, at periodic intervals as documented in the specifications on controls checks of the graded timber (see A.10), direct measurement of the structural properties of full-size timber shall be undertaken. Such direct measurement should be based on the requirements of A.8.1 or another procedure providing statistically reliable data equivalent to A.8.1 and so documented in the specifications on control checks.

NOTE 1 An equivalent evaluation procedure may be strength evaluations based on proof loading to approximately the 10-percentile value, and where the unbroken pieces may be returned to production.

NOTE 2 The periodic evaluation criteria verify the acceptability of the material as meeting the stated (or claimed) characteristic strengths and modulus and not necessarily the data as developed from the initial evaluation.

Sampling for this purpose should be undertaken during normal production. The sampling rate recommended is a minimum of 1 in 10 000 pieces of timber graded, and a rate of 1 in 1 000 when tight control is required. The timber is tested to measure bending strength and modulus of elasticity.

A check is made when the sample size for a given grade/size has the value N given by

$$N = 1\,000 (CV)^2 \quad (\text{A.1})$$

where

CV is the coefficient of variation of the bending strength.

The 5-percentile of the bending strength data, denoted by $f_{m,0,05,data}$ shall satisfy the following criterion

$$f_{m,0,05,data} > 0,91 f_{m,0,05,target} \quad (\text{A.2})$$

where

$f_{m,0,05,target}$ is the target 5-percentile for the grade/size.

If the sample fails to satisfy this criterion, then a second sample shall be taken as soon as possible and tested according to the same criterion. If this second sample passes the criterion, then production may proceed without further delay; if however the second sample also fails, then there is a probability that there is an error in the grading process and action should be undertaken to determine and correct the cause.

Where specified, the above procedure may be applied to the tension strength.

The mean value of modulus of elasticity, denoted by $E_{mean,data}$ shall comply with the following criterion

$$E_{mean,data} > 0,96 E_{mean,target} \quad (\text{A.3})$$

where

$E_{mean,target}$ is the target mean value for the grade/size.

If the sample fails to satisfy this criterion, then a second sample shall be taken as soon as possible and tested according to the same criterion. If this second sample passes the criterion, then production may proceed without further delay; if however the second sample also fails, then there is a probability that there is an error in the grading process and action should be undertaken to determine and correct the cause.

A.9 Product identification

Except for exceptional circumstances where the end use of the timber may require marking to be omitted for aesthetic reasons and where the customer specifically requests/orders timber to be free of marks, timber shall be marked to identify:

- a) reference to this standard;
- b) producer responsible;
- c) grade;
- d) certification body;
- e) timber condition (stated/claimed moisture content at the time of grading); and
- f) species or species mixture (group) and origin (growth range).

Figure A.9 provides a visual reference of a mark providing this required information.

For those cases where the customer specifically requests/orders timber free of marks, each parcel/package of timber of a single grade/strength class shall be dispatched under the cover of a certificate of compliance stating the following information:

- g) serial name and date of the certificate;
- h) customer's name and address;
- i) customer's purchase or order number;
- j) species or species mixture (species group), grade, and dimensions and quantities, grade;
- k) reference to this standard, timber condition (stated/claimed moisture content at the time of grading, and date the timber was graded); and
- l) signature of the operator or of the grader.

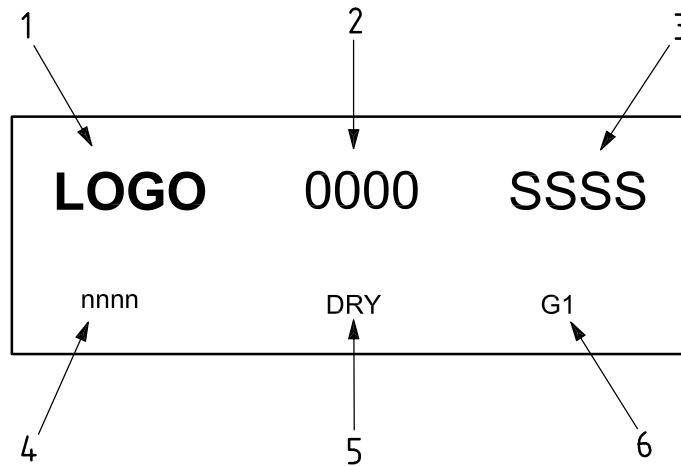

Key

- 1 certification body LOGO or MARK
- 2 grader and/or company reference
- 3 species or species group
- 4 standard reference (a reference to this example standard)
- 5 timber condition (as defined in this example standard, i.e. seasoned, dry, or unseasoned)
- 6 grade (see Table A.1, i.e. G1 or G2)

Figure A.9 — Example of a mark on visually strength-graded timber

A.10 Documentation

A quality manual shall include the following:

- a) specifications of the resource input;
- b) this standard;
- c) definition of the grade sorting process;
- d) specifications of the structural and utility requirements;
- e) specifications on controls for the grade sorting process;
- f) specifications on the methods used to initially and periodically evaluate the properties of the timber;
- g) specifications on control checks of graded timber;
- h) specifications of the information marked on the timber, or where applicable for timber ordered free of marks specifications for the certificate of compliance accompanying each parcel/package of timber;
- i) allocation of responsibilities for quality control operations; and
- j) specifications used by the certification body.

Annex B (informative)

Example of a visual strength-grading timber standard — based on the need for design values where a high degree of certainty of structural properties is *not* required

This is one of a number of possible systems provided as an example only - not a system proposed for universal usage. This example is a practical implementation of the visual strength-grading principles defined in the main body of ISO 9709, as applied to the following case:

- rectangular timber
- for structural applications
- where a high degree of engineering reliability is not required.

The layout corresponds to that of an International Standard (not a normal Annex) to clearly show how an International Standard in this domain should look. It includes both

- normative elements (Scope, Terms and definitions, Symbols and abbreviated terms, Requirements, Sampling, Test methods), and
- supplementary informative elements (Bibliography).

Informative annexes (like this Annex B) and normative annexes may also form part of an International Standard.

NOTE The Scope does not usually form part of an annex, but is included in this example for completeness purposes.

B.1 Scope

This standard specifies the grading procedures for producing visually sorted strength and stiffness graded rectangular timber for structural applications where a high degree of engineering reliability is not required.

It is applicable for timber that is graded in the seasoned state where the strength characteristic values within 30 % of the expected values are acceptable.

B.2 Normative references

The following referenced documents are indispensable for the application of this document. For dated references, only the edition cited applies. For undated references, the latest edition of the referenced document (including any amendments) applies.

ISO 9709, *Structural timber — Visual strength grading — Basic principles*

ISO 13910, *Structural timber — Characteristic values of strength-graded timber — Sampling, full-size testing and evaluation*

B.3 Terms and definitions

For the purposes of this document, the following terms and definitions apply.

B.3.1

density

mass per unit volume expressed as kilograms per cubic metre at a moisture content of 12 %

B.3.2

grade

population of timber, derived from a specified resource by applying a specified sorting procedure

B.3.3

pith

small soft core in the biological centre of a log

B.3.4

pocket

a well-defined opening between the rings of annual growth which develops during the growth of the tree and typically contains resin or bark

B.3.5

seasoned timber

timber with an estimated average moisture content of 15 % or less at the time of grading

B.3.6

thickness

lesser dimension perpendicular to the longitudinal axis of a piece of timber

B.3.7

utility requirements

grade requirements that are non-structural

B.3.8

width

greater dimension perpendicular to the longitudinal axis of a piece of timber

B.4 General

B.4.1 Visual strength-grading operations

The visual strength-grading operation shall be comprised of a visual grader who sorts an input resource into four output grades. Some of the timber may not meet the requirements of the minimum grade.

B.4.2 Principles of quality control

This standard requires that the quality control be undertaken by placing checks on the resource input, the visual grade sorting, and the graded timber output.

B.5 Resource input requirements

The input resource shall be defined in terms of timber species or mixture of species, log size, log source and the sawn timber's moisture condition and content.

B.6 Strength-grading requirements

B.6.1 Limits for grade sorting

B.6.1.1 For structural purposes

The acceptable limits on features for grade GG-3, are given in Table B.1 and illustrated in Figure B.1.

Table B.1 — Sorting limits for structural grade GG-3

Sorting feature	Feature limit Grade GG-3
Width of knot size and pockets ^a	1/2 surface
Slope of grain	1 in 5
Length of splits and resin veins	3 times width of timber
Pith	none
^a Check all four surfaces.	

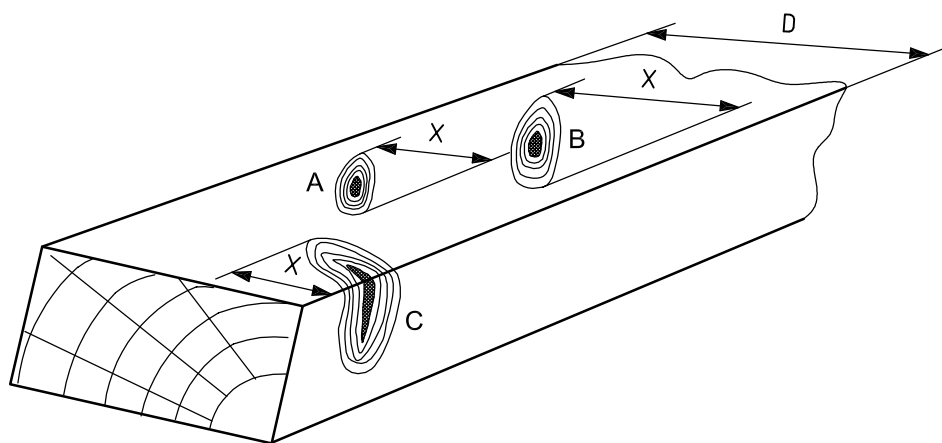

a) Knot size

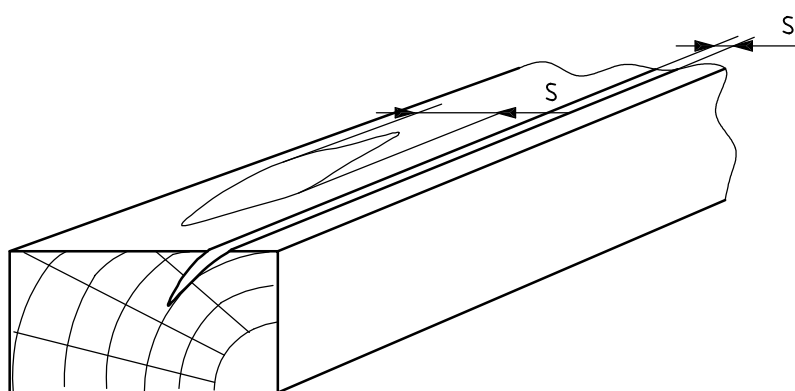

b) Width of pocket

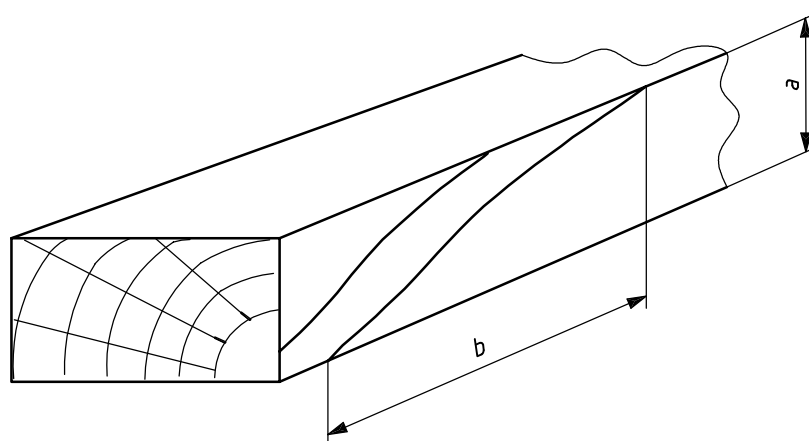

c) Slope of grain

Key

X knot size

S width of pocket

a/b slope of grain

Figure B.1 — Method of measurement of structural features

B.6.1.2 For utility purposes

No pith is permitted.

The spring of the timber shall be measured as indicated in Figure B.2 and shall not exceed 10 mm per meter of length of the timber.

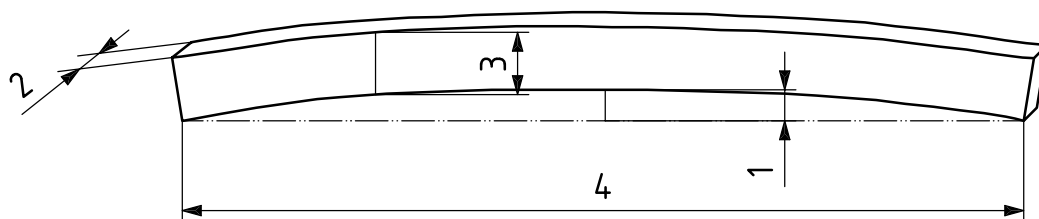
**Key**

- 1 spring
- 2 thickness
- 3 width
- 4 length

Figure B.2 — Measurement of spring

B.6.2 Check on grading process

During each production shift some check shall be made to assess the accuracy of the grade sorting process.

B.7 Structural properties**B.7.1 General**

The structural properties are defined and measured as specified in the ISO 13910.

NOTE ISO 9709 principles identify that the structural properties may be incorporated in the visual strength-grading standard or may be in other appropriate standards referencing the grades determined using the criteria of the visual strength-grading standard. This Annex B example standard incorporates the criteria used to define characteristic values of the structural properties but does not list the properties.

B.7.2 Initial evaluation

The timber species (or species mixture) shall be classified according to its density as stated in Table B.2. Density shall be measured on pieces of full cross-section cut from clear wood from the structural timber. A minimum sample of 10 specimens shall be used. The specimens shall be selected at random. The average value shall be used for classification purposes.

Table B.2 — Classification limits for clear wood density

Mean density at 12 moisture content (kg/m ³)	Species class
400	IC – 1
600	IC – 2
800	IC – 3
1 000	IC – 4

B.7.3 Periodic evaluation

Each working day a piece of strength-graded timber shall be selected at random and set aside. When 20 such pieces have been collected a check shall be made with respect to resource, moisture content, grade and classification of the timber.

B.8 Product identification

Timber shall be marked to indicate reference to this standard, the grade (GG-3) and the species class (IC-1, IC-2, IC-3, or IC-4), and the producer responsible.

B.9 Documentation

A quality manual shall include:

- a) specifications of the resource;
- b) this standard;
- c) the grade sorting process;
- d) timber grade specifications; and
- e) mark specifications.

Bibliography

Grade sorting standards

- [1] Australian Standard AS 2082, *Visually stress-graded hardwood for structural purposes*
- [2] Australian Standard AS 2858, *Timber—Softwood —Visually stress-graded for structural purposes*
- [3] Belgian Standard, Specifications unifiées STS 04 — *Bois et panneaux base de bois*
- [4] British Standard BS 4978, *Specification for visual strength grading of softwood*
- [5] British Standard BS 5756, *Specification for visual strength grading of hardwood*
- [6] French Standard NF B 52–001, *Regles d'utilisation du bois dans les constructions — Classement visuel pour l'emploi en structure pour les principales essences résineuses et feuillues*
- [7] German Standard DIN 4074 Teil 1, *Sortierung von nadelholz nach der tragfähigkeit, nadelschnittholz*
- [8] Irish Standard IS I27, *Specifications for stress grading soft wood timber*
- [9] Italian Standard UNI 8198, *Segati di conifere. Classificazione in base alla resistenza meccanica*
- [10] Japanese Agriculture Standard JAS 143, *Structural softwood lumber*
- [11] Japanese Agriculture Standard, JAS 600, *Structural lumber for wood frame construction*
- [12] Korean Standard, KS F 2151 *Visual grading for softwood structural lumber*
- [13] National Lumber Grades Authority (NLGA), *Standard Grading Rules for Canadian Lumber*
- [14] New Zealand NZ S 3631 *Timber Grading Rules*
- [15] Nordic grading rules — INSTA 142, *Nordic visual stress grading rules for timber*
- [16] South African Standard SABS 1783, *Sawn Softwood Timber*
- [17] Western Wood Products Association, *Western Lumber Grading Rules* (and other grading rules certified by the American Lumber Standard Committee)

Quality control standards

- [18] Australian Standard AS 2082, *Timber — Hardwood — Visually stress-graded for structural purposes*
- [19] Australian/New Zealand Standard AS/NZS 4063, *Timber — Stress-graded — In-grade strength and stiffness evaluation*
- [20] Australian/New Zealand Standard AS/NZS 4490, *Timber — Stress-grading — Procedure for Monitoring Structural Properties*
- [21] Canadian Standard CAN/CSA–0141, *Softwood lumber*
- [22] South Africa Standard SABS Method 1122
- [23] USA Standard PS 20, *American Softwood Lumber Standard*

1

ICS 79.040

Price based on 25 pages