

INTERNATIONAL
STANDARD

ISO
9667

Second edition
2016-01-15

**Aircraft ground support
equipment — Tow bars**

Équipement au sol pour aéronefs — Barres de tractage



Reference number
ISO 9667:2016(E)

© ISO 2016



COPYRIGHT PROTECTED DOCUMENT

© ISO 2016, Published in Switzerland

All rights reserved. Unless otherwise specified, no part of this publication may be reproduced or utilized otherwise in any form or by any means, electronic or mechanical, including photocopying, or posting on the internet or an intranet, without prior written permission. Permission can be requested from either ISO at the address below or ISO's member body in the country of the requester.

ISO copyright office
Ch. de Blandonnet 8 • CP 401
CH-1214 Vernier, Geneva, Switzerland
Tel. +41 22 749 01 11
Fax +41 22 749 09 47
copyright@iso.org
www.iso.org

Contents

Page

Foreword	iv
1 Scope	1
2 Normative references	1
3 Aircraft mass categories	1
4 Tow bar general requirements	2
5 Aircraft connection	2
5.1 Dimension of tow bar connection to aircraft	2
5.2 Aircraft interface requirements	2
5.3 Aircraft protective provisions	2
5.3.1 General requirements	2
5.3.2 Shear pins	3
5.3.3 Marking	4
6 Tractor connection	4
7 Tow bar undercarriage	5

Foreword

ISO (the International Organization for Standardization) is a worldwide federation of national standards bodies (ISO member bodies). The work of preparing International Standards is normally carried out through ISO technical committees. Each member body interested in a subject for which a technical committee has been established has the right to be represented on that committee. International organizations, governmental and non-governmental, in liaison with ISO, also take part in the work. ISO collaborates closely with the International Electrotechnical Commission (IEC) on all matters of electrotechnical standardization.

The procedures used to develop this document and those intended for its further maintenance are described in the ISO/IEC Directives, Part 1. In particular the different approval criteria needed for the different types of ISO documents should be noted. This document was drafted in accordance with the editorial rules of the ISO/IEC Directives, Part 2 (see www.iso.org/directives).

Attention is drawn to the possibility that some of the elements of this document may be the subject of patent rights. ISO shall not be held responsible for identifying any or all such patent rights. Details of any patent rights identified during the development of the document will be in the Introduction and/or on the ISO list of patent declarations received (see www.iso.org/patents).

Any trade name used in this document is information given for the convenience of users and does not constitute an endorsement.

For an explanation on the meaning of ISO specific terms and expressions related to conformity assessment, as well as information about ISO's adherence to the WTO principles in the Technical Barriers to Trade (TBT) see the following URL: [Foreword - Supplementary information](#)

The committee responsible for this document is ISO/TC 20, *Aircraft and space vehicles*, Subcommittee SC 9, *Air cargo and ground equipment*.

This second edition cancels and replaces the first edition (ISO 9667:1998), which has been technically revised.

Aircraft ground support equipment — Tow bars

1 Scope

This International Standard specifies dimensional and physical requirements of tow bar connections to tractor and aircraft (see [Figure 1](#)). It is applicable to any new type of commercial-transport-category aircraft tow bar designed or built after publication of this International Standard.

The purpose of this International Standard is to standardize tow bar attachments to airplane and tractor according to the mass category of the towed aircraft, so that one tow bar head with different shear levels can be used for all aircraft that are within the same mass category and are manufactured in compliance with ISO 8267 (all parts).

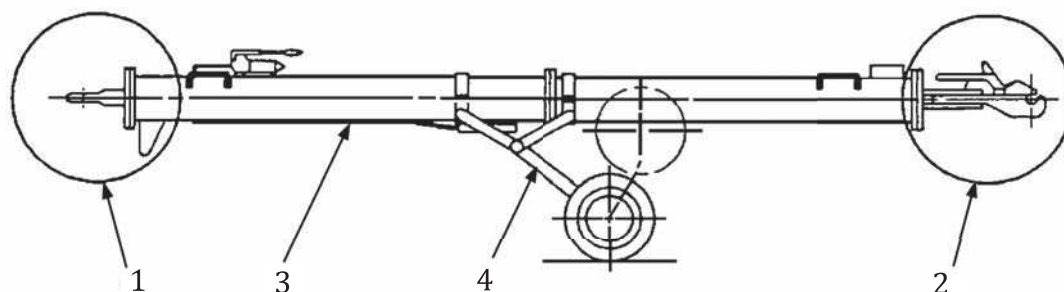

Key

- 1 tractor connection
- 2 aircraft connection
- 3 tow bar body
- 4 tow bar undercarriage

Figure 1 — Tow bar

2 Normative references

The following documents, in whole or in part, are normatively referenced in this document and are indispensable for its application. For dated references, only the edition cited applies. For undated references, the latest edition of the referenced document (including any amendments) applies.

ISO 8267-1, *Aircraft — Tow bar attachment fittings interface requirements — Part 1: Main line aircraft*

ISO 8267-2, *Aircraft — Tow bar attachment fittings interface requirements — Part 2: Regional aircraft*

EN 12312-7:2005+A1:2009, *Aircraft ground support equipment — Specific requirements — Part 7: Aircraft movement equipment*

3 Aircraft mass categories

The aircraft mass categories shall be in accordance with ISO 8267 (all parts).

A given tow bar type may be used on several aircraft types within the same ISO 8267-1 or ISO 8267-2, as appropriate, weight category, provided

- their nose landing gear towing interface meets the ISO 8267-1 or ISO 8267-2 requirements for that category, and
- the protective provisions are chosen to meet or exceed the minimum requirement for each aircraft.

4 Tow bar general requirements

As a safety feature the tow bar (body or head holding section or retaining feature) shall be designed to sustain at least 150 % of the protective device(s) functioning point or as otherwise specified by the customer.

The tow bar, when unladen, shall be both towable and stable at speeds up to 25 km/h (15 mph). The maximum towing speed shall be suitably placarded.

For use in the EU and EFTA, the tow bar shall, in addition, meet the Health and Safety requirements contained in EN 12312-7:2005, 5.9.

5 Aircraft connection

5.1 Dimension of tow bar connection to aircraft

The standard configuration of the tow bar connection to the aircraft shall be compatible with the horizontal pin of the aircraft tow bar attachment fitting as specified in ISO 8267 (all parts).

NOTE Several common aircraft types designed prior to publication of ISO 8267 (all parts) still use non-standard nose gear tow bar attachment fittings. Refer to the aircraft type manufacturer's documentation for interface requirements.

5.2 Aircraft interface requirements

The design of the tow bar aircraft connection device that clamps to the horizontal cylindrical pin of the aircraft

- shall grip the pin uniformly over 96 % to 98 % of its length,
- shall be designed to eliminate inadvertent disengagement of the tow bar during towing or pushing operations,
- shall be designed to provide adequate clearance during engagement and disengagement of the tow bar from the aircraft connection [allowable space envelope for clearance is specified in ISO 8267 (all parts)], and
- should be adjustable to provide pressure on the pin when locked.

NOTE Several common aircraft types designed prior to publication of ISO 8267 (all parts) still use non-standard nose gear tow bar attachment fittings. Refer to the aircraft type manufacturer's Aircraft Characteristics for Airport Planning Manual for interface requirements.

5.3 Aircraft protective provisions

5.3.1 General requirements

The tow bar should be so constructed as to prevent any item from becoming a Foreign Object Damage (FOD) hazard, e.g. broken parts of the shear pin and any bushes always remain captive to prevent aircraft engine ingress.

The tow bar shall incorporate a device or devices, such as for example shear pins (typically two, respectively for push/pull and torsion protection), to protect the aircraft from damage due to towing which shall

- relieve fore/aft and torsional towing forces applied to the aircraft nose gear through the tow bar which exceed the maximum force recommendations of the aircraft manufacturer by means of a shock absorbing device that is designed to function at values below tow bar design values,
- have an energy-absorbing device in order to limit loads induced in the landing gear that shall be designed to function at values beyond tow bar design values,
- simultaneously alert the tow tractor operator, audibly, visually or both, that a device has been actuated,
- be replaceable or repairable with a minimum of effort, and
- transfer overload to a retaining feature preventing separation and therefore loss of control of the aircraft from the towing vehicle. The retaining feature shall allow free rotation on $\pm 90^\circ$ about aircraft centreline at the retaining fastener. The retaining feature should be designed so that the towing forces do not exceed the aircraft type manufacturer's maximum force recommendations. See [Figure 2](#) example.

5.3.2 Shear pins

If shear pins are used as a protective device, they shall

- discourage hazardous replacement and encourage the exclusive use of manufacturer's original parts and be clearly identified for their specific usage,
- shear at or below the nominal force specified by the aircraft manufacturer(s),
- have a functioning point within a relative tolerance of (+0/-10 %), and
- have a specific predetermined shear plane, whether provided with or without hardened bushings (see [Figure 2](#)).

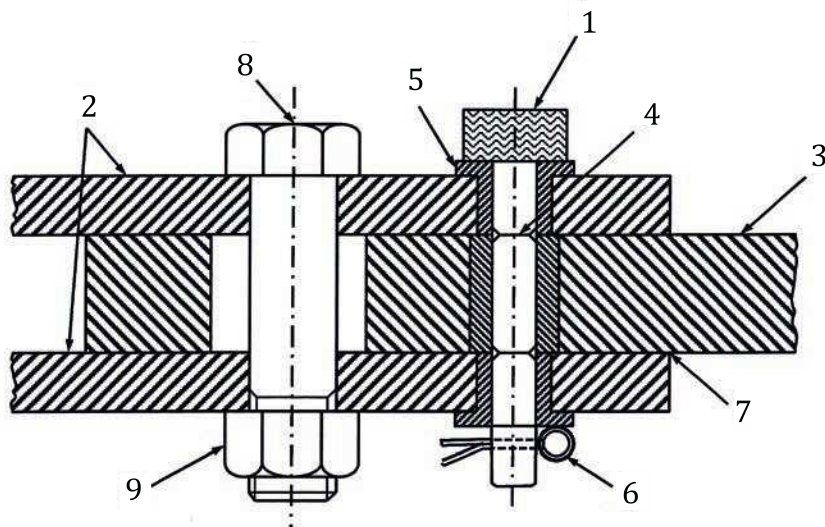

Key

- 1 shear pin
- 2 head retention plates
- 3 head
- 4 preset shear plane
- 5 hardened steel bushings
- 6 retaining clip
- 7 sliding fit
- 8 head retention bolt
- 9 self-locking nut

NOTE Do not clamp up assembly.

Figure 2 — Typical shear pin/bushing configuration

5.3.3 Marking

The tow bar shall be clearly and indelibly marked to identify the allowable type(s) of aircraft and maximum towing force.

6 Tractor connection

The attachment on the tow bar for connection to the tractor

- shall be as shown in [Figure 3](#) for all mass categories as specified in [Clause 3](#), and
- shall contain a rotating tow bar eye.

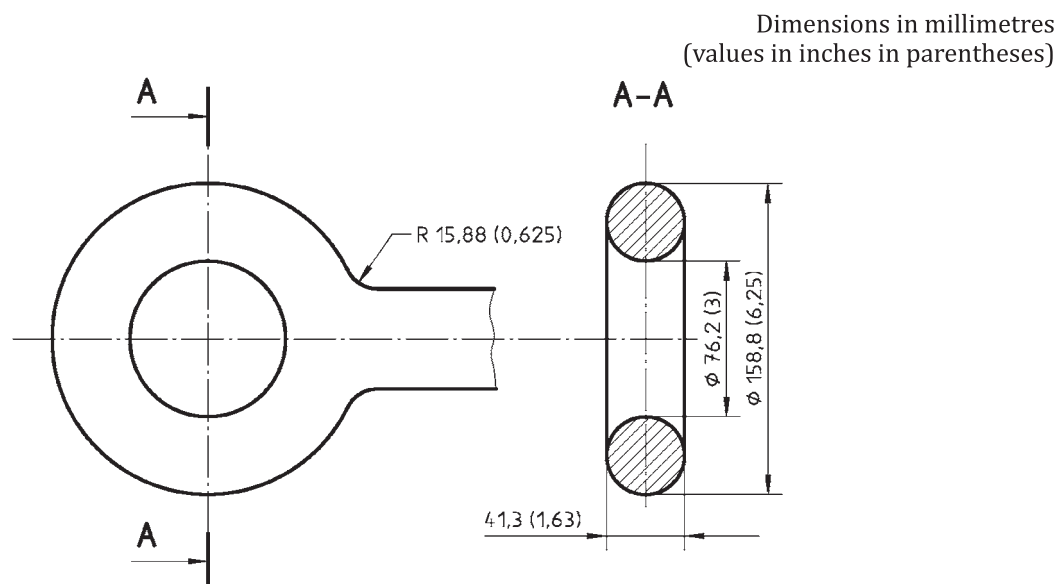

Figure 3 — Dimensions of tow bar eye (tractor connection)

7 Tow bar undercarriage

The tow bar shall be equipped with a wheeled undercarriage to support it while being moved unladen and to serve as height adjustment device while attaching the end connections.

The undercarriage shall be extendable by use of a mechanical device, or a hand pump and hydraulic cylinder. It shall retract mechanically or by hydraulic pressure release.

Height adjustment shall cover the range necessary for connecting to and towing all aircraft types the tow bar is intended for, with the wheels clearing ground by a minimum of 50 mm (2 in) during towing.

Longitudinal adjustment of the undercarriage shall allow centre of gravity adjustments in the event of, e.g. changing the tow bar head or installing a Ground Power Unit cable.

- Where design is such that the tow bar is attached below the aircraft towing spool (see [Figure 4](#)), the tow bar centre of gravity shall ensure it is heavier at the tractor end by no more than 12 kg (25 lb).
- Where design is such that the tow bar is attached above the aircraft towing spool (see [Figure 5](#)), the tow bar centre of gravity shall ensure it is heavier at the aircraft end by no more than 12 kg (25 lb).

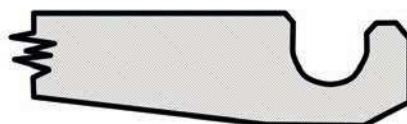

Figure 4 — Attachment below aircraft spool

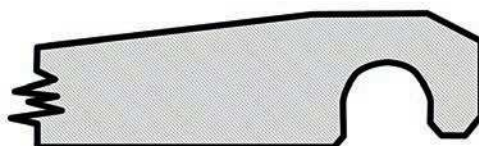

Figure 5 — Attachment above aircraft spool

