

INTERNATIONAL STANDARD

ISO
9652-5

First edition
2000-03-01

Masonry — **Part 5:** **Vocabulary**

Maçonnerie —
Partie 5: Vocabulaire



Reference number
ISO 9652-5:2000(E)

© ISO 2000

PDF disclaimer

This PDF file may contain embedded typefaces. In accordance with Adobe's licensing policy, this file may be printed or viewed but shall not be edited unless the typefaces which are embedded are licensed to and installed on the computer performing the editing. In downloading this file, parties accept therein the responsibility of not infringing Adobe's licensing policy. The ISO Central Secretariat accepts no liability in this area.

Adobe is a trademark of Adobe Systems Incorporated.

Details of the software products used to create this PDF file can be found in the General Info relative to the file; the PDF-creation parameters were optimized for printing. Every care has been taken to ensure that the file is suitable for use by ISO member bodies. In the unlikely event that a problem relating to it is found, please inform the Central Secretariat at the address given below.

© ISO 2000

All rights reserved. Unless otherwise specified, no part of this publication may be reproduced or utilized in any form or by any means, electronic or mechanical, including photocopying and microfilm, without permission in writing from either ISO at the address below or ISO's member body in the country of the requester.

ISO copyright office
Case postale 56 • CH-1211 Geneva 20
Tel. + 41 22 749 01 11
Fax + 41 22 734 10 79
E-mail copyright@iso.ch
Web www.iso.ch

Printed in Switzerland

Contents

Page

Foreword.....	iv
1 Scope	1
2 Normative reference	1
3 Units	1
4 Mortar	6
5 Ancillary components	7
6 Structural design	8
7 Structural components	11
8 Miscellaneous terms	13
9 Test methods and equipment.....	13
10 Dimensions and mass.....	14
11 Water-related properties	15
Bibliography	16
Index.....	17

Foreword

ISO (the International Organization for Standardization) is a worldwide federation of national standards bodies (ISO member bodies). The work of preparing International Standards is normally carried out through ISO technical committees. Each member body interested in a subject for which a technical committee has been established has the right to be represented on that committee. International organizations, governmental and non-governmental, in liaison with ISO, also take part in the work. ISO collaborates closely with the International Electrotechnical Commission (IEC) on all matters of electrotechnical standardization.

International Standards are drafted in accordance with the rules given in the ISO/IEC Directives, Part 3.

Draft International Standards adopted by the technical committees are circulated to the member bodies for voting. Publication as an International Standard requires approval by at least 75 % of the member bodies casting a vote.

Attention is drawn to the possibility that some of the elements of this part of ISO 9652 may be the subject of patent rights. ISO shall not be held responsible for identifying any or all such patent rights.

International Standard ISO 9652-5 was prepared by Technical Committee ISO/TC 179, *Masonry*, Subcommittee SC 3, *Test methods*.

ISO 9652 consists of the following parts, under the general title *Masonry*:

- *Part 1: Unreinforced masonry design by calculation*
- *Part 2: Unreinforced masonry design by simple rules*
- *Part 3: Reinforced masonry design by calculation*
- *Part 4: Test methods*
- *Part 5: Vocabulary*

Masonry —

Part 5: Vocabulary

1 Scope

This part of ISO 9652 defines terms used in the structural design of unreinforced masonry.

This part of ISO 9652 is applicable to masonry in general, except for the following aspects of masonry design:

- a) seismic design;
- b) resistance to fire (see ISO/IEC Guide 52);
- c) thermal insulation (see ISO 7345);
- d) sound insulation.

NOTE It is assumed that the design of masonry is entrusted to structural or civil engineers or other appropriately qualified persons for whose guidance this International Standard was prepared.

2 Normative reference

The following normative document contains provisions which, through reference in this text, constitute provisions of this part of ISO 9652. For a dated reference, subsequent amendments to, or revisions of, the publications do not apply. However, parties to agreements based on this part of ISO 9652 are encouraged to investigate the possibility of applying the most recent edition of the normative document indicated below. For an undated reference, the latest edition of the normative document referred to applies. Members of ISO and IEC maintain registers of currently valid International Standards.

ISO 9652-1:—¹⁾, *Masonry — Part 1: Unreinforced masonry design by calculation.*

3 Units

3.1

masonry unit

preformed component, intended for use in bonded masonry construction

SEE 9.1 of ISO 9652-1:—¹⁾

NOTE In the following terms and definitions, the term “masonry unit” is for simplicity referred to as “unit”.

1) To be published.

3.2 Unit types according to material

3.2.1

calcium silicate unit

unit formed from a mixture of lime and predominantly siliceous materials, shaped by pressing and combined by the action of steam under pressure

3.2.2

clay unit

unit formed predominantly from clay, loam, brickearth or shale, subsequently fired to a temperature sufficiently high to produce an adequate ceramic bond

3.2.3 Concrete units

3.2.3.1

autoclaved aerated concrete unit

unit formed from a mixture of fine siliceous aggregate, hydraulic binder, other materials and an aeration agent, then autoclaved after rising and cutting

3.2.3.2

dense-aggregate concrete unit

unit formed from a mixture of normal-density aggregate, hydraulic binder and other materials, moulded under pressure and/or vibration

3.2.3.3

lightweight-aggregate concrete unit

unit formed from a mixture of low-density inorganic principal aggregate, hydraulic binder and other materials, moulded under pressure and or vibration

3.2.4 Stone units

3.2.4.1

dressed stone unit

unit formed from natural stone by cutting or cleaving to a regular rectangular shape

3.2.4.2

manufactured stone unit

unit formed from aggregate and cementitious binder; intended to resemble, and to be used for similar purposes to that of, natural stone

3.3 Grouping of units according to their percentage and direction of holes as laid in the wall

3.3.1

group 1 unit²⁾

units without, or with less than or equal to 25 % by volume of, formed vertical voids that may or may not pass right through the unit or unit with less than or equal to 25 % by volume of frogs in the bed faces

See Figure 1a).

3.3.2

group 2 unit²⁾

unit with more than 25 % and less than 60 % by volume of formed vertical voids that may or may not pass right through the unit

See Figure 1b).

2) Units in which voids are filled with thermal insulating material are not considered to be solid.

3.3.3**group 3 unit²⁾**

unit with less than 50 % by volume of formed horizontal voids that may or may not pass right through the unit

See Figure 1c).

3.4 Terms relating to units**3.4.1****cells**

formed voids which do not pass through a masonry unit

3.4.2**frog**

depression formed in one or both bed faces of a unit, the total volume of which does not exceed 25 % of the gross volume of the unit

See Figure 2.

3.4.3**grip-hole****hand-hold**

two or more formed voids in a unit to enable it to be more readily grasped and lifted with one or both hands or by a machine

3.4.4**hole core US**

formed void which passes completely through a masonry unit

3.4.5**void**

empty space

3.4.6**web**

solid material between the voids in a masonry unit

See Figure 3.

3.4.7**shell**

peripheral solid material of a masonry unit including that between a void and end of a unit

See Figure 3.

3.4.8**face shell**

solid material between the voids and the front and rear faces of a masonry unit

See Figure 3.

3.5 Size**3.5.1****coordinating size**

nominal size (deprecated)

size of a coordinating space allocated to a unit including allowances for joints and tolerances

3.5.2**work size**

size of a unit specified for its manufacture to which the actual size should conform within specified permissible deviations

3.5.3

actual size

size of a unit as measured

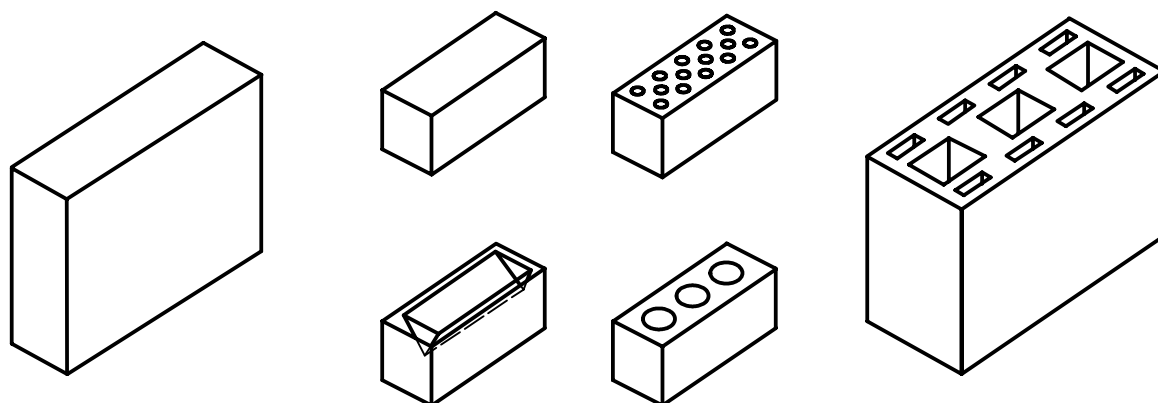

a) Group 1 units

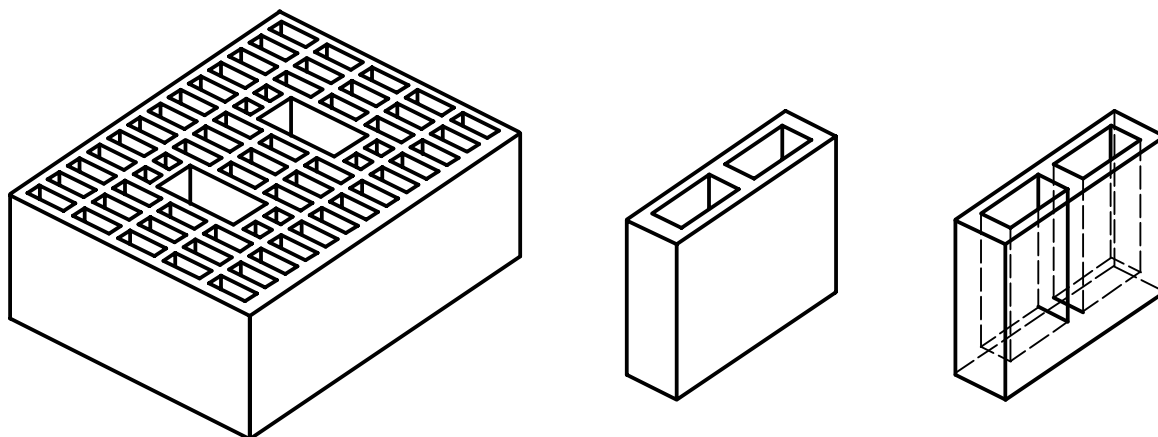

b) Group 2 units

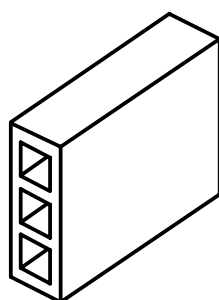

c) Group 3 unit

Figure 1 — Units in normal view

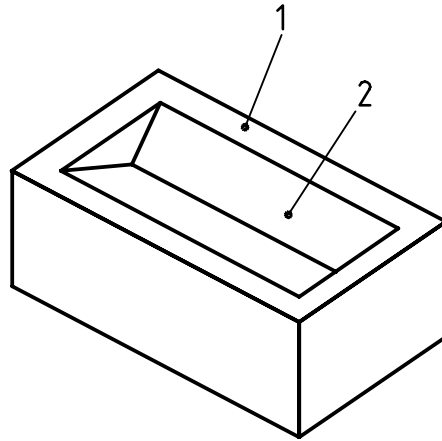

Key

- 1 Bed face
- 2 Frog

Figure 2 — Frog

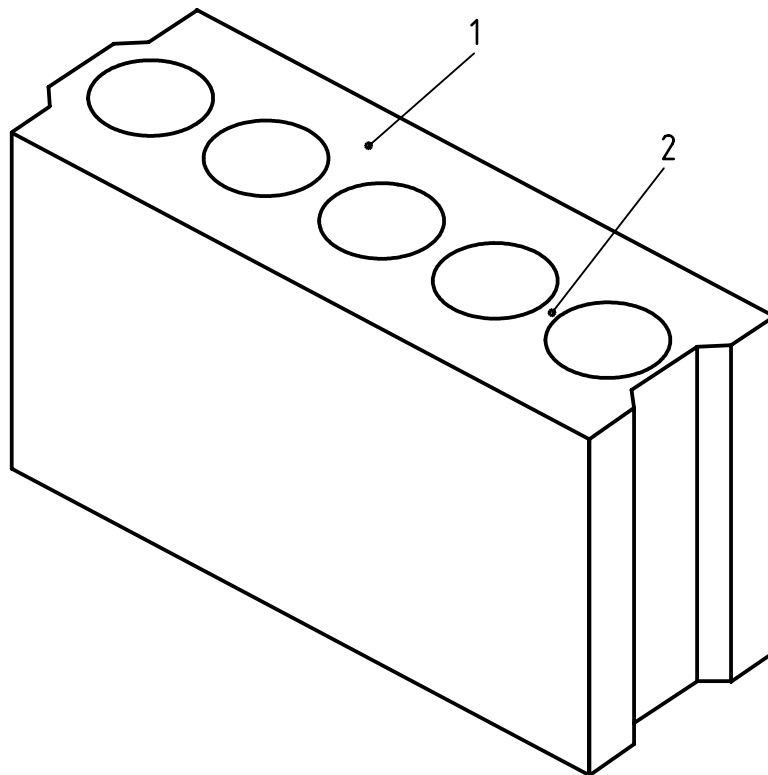

Key

- 1 Face shell
- 2 Web

Figure 3 — Shell and web

4 Mortar

4.1 addition

finely divided inorganic material that may be added to concrete or mortar in order to improve properties or to achieve special properties

4.2 admixture

material added in small quantities in relation to the mass of the cement, before or during mixing of the mortar or concrete to produce specified modifications to the properties

4.3 binder

material used to hold solid particles together in a coherent mass

4.4 masonry cement

factory-made, finely powdered hydraulic binder consisting of Portland cement clinker, inorganic materials and, where appropriate, specified organic materials

4.5 face-shell bedding

two separate strips of mortar covering the front and rear faces of the units in both horizontal and vertical joints

4.6 grout

mortar or concrete of suitable consistency and particle size to fill cavities or holes in masonry

4.7 lime

product, consisting mainly of calcium oxide, obtained by heating limestone or other material containing calcium carbonate

4.7.1 hydrated lime

fine, dry powder consisting mainly of calcium hydroxide

4.7.2 lime putty

mixture of hydrated lime and water in plastic form ready for addition to mortar or grout

4.7.3 hydraulic lime

lime containing sufficient soluble silica, aluminates, etc. to enable it to set in the presence of water

4.8 mortar

material consisting of a mixture of inorganic binders, aggregates and water which may also contain additions and admixtures

NOTE Mortar is used for bedding, jointing, pointing or grouting of masonry.

4.8.1 lightweight mortar

mortar using lightweight aggregates and having a dry hardened density of less than 1 500 kg/m³

4.8.2**factory-made mortar**

mortar batched and mixed in a factory and supplied to the building site

4.8.3**ready-mixed mortar**

dry factory-made mortar to which water is added on site

4.8.4**ready-to-use mortar**

factory-made mortar containing a retarder to delay the set for sufficient time to allow for delivery and use

4.8.5**thin-layer mortar**

ready-mixed mortar with a maximum particle size of 1 mm, containing additions and admixtures intended for use in beds not less than 1 mm nor greater than 3 mm thick

4.9**mortar bond**

adhesion of the jointing mortar to the masonry units

4.10 Mortar joints**4.10.1****jointing**

finishing of a mortar joint as the work proceeds

4.10.2**pointing**

filling and finishing of raked-out joints

4.10.3**bed joint**

mortar layer on which masonry units are set

4.10.4**collar joint**

continuous vertical joint, between two leaves parallel to the face of the wall

4.10.5**cross joint**

vertical joint perpendicular to the face of the wall

4.10.6**perpend****head joint**

cross joint between two units

4.10.7**thin-layer joint**

joint with a maximum thickness of 3 mm

5 Ancillary components**5.1****connector**

component to attach two assemblies to one another

EXAMPLE A floor or a roof can be connected to a wall.

NOTE The term connector includes anchors, **straps** and **ties** (5.5.4).

5.2
damp-proof course
dpc

layer or coating of material covering the bedding surface of a masonry wall to resist the passage of water

5.3
joist hanger

metal connector, one end of which is firmly supported by a wall or other structural member and into which the end of a joist (timber beam) sits

5.4
lintel

beam over an opening in a wall

5.5 Steel

5.5.1
galvanized steel

steel coated with zinc to a prescribed weight per unit area

5.5.2
low-carbon steel

steel having a mass fraction of carbon not greater than 0,2 %

5.5.3
stainless steel

alloy steel which contains substantial quantities of chromium, with or without the addition of nickel and other elements, and which is resistant to many forms of corrosive attack

5.5.4
strap
tie

connector capable of transferring loads from one part of the structure to another

5.5.5
wall tie

connector capable of transferring loads from one wall or leaf to another wall or leaf

6 Structural design

6.1
eccentricity

distance between the line of action of a load and the centroid of the supporting member

6.1.1
accidental eccentricity
unintentional eccentricity

EXAMPLE Accidental eccentricities can be due to workmanship.

6.1.2
structural eccentricity
eccentricity due to the assumed behaviour of the structure

6.2 Height

6.2.1

clear height

height between the top surface of a floor and the underside of the structural floor above or between the top floor and a roof

6.2.2

effective height

value used in structural calculations to represent the height of a wall, pier or column allowing for restraints

6.2.3

storey height

distance between the centre of one floor and the centre of the next or the centre of the roof

6.3

stiffened section

combination of two or more intersecting walls to make one composite section

6.4

effective width

that part of a wall taken into account in the design of a stiffened section

6.5 Load

6.5.1

accidental load

load, which is not specifically foreseen because its occurrence is unlikely, but for which an allowance is made in design

6.5.2

dead load

load of constant magnitude and position that acts permanently, including self weight

6.5.3

characteristic dead load

dead load based on specified dimensions and densities

6.5.4

imposed load

load on a structure or member, other than wind load, produced by the external environment and intended occupancy and use

EXAMPLE Snow or moveable partitions.

6.5.5

wind load

load caused by wind flow around structures which exerts lateral or vertical pressure

6.5.6

characteristic imposed or wind load

load which has a probability of not more than 5 % of being exceeded where it acts unfavourably or, where it acts favourably, the load which has a probability of at least 95 % of being exceeded

6.6 Loading conditions

6.6.1

axial loading

application of a load to a member along an axis

6.6.2

concentric loading

application of a load to the centroid of the plan area of a member

6.6.3

eccentric loading

application of a load to a member at a distance from its centroid

SEE 6.4

6.6.4

lateral loading

application of a load to a column or wall at right angles to its vertical plane

6.7

movement joint

control joint

joint designed to permit movement in the plane of the wall to occur without impairing its functional integrity

6.8

restraint

means of restricting movement in one or more directions which may be horizontal or vertical

6.8.1

lateral restraint

⟨wall or pier⟩ restraint acting in the direction of the thickness

6.8.2

lateral restraint

⟨column⟩ restraint acting in the direction of the thickness or width

6.8.3

fixed restraint

lateral restraint that substantially restricts rotation

6.8.4

simple restraint

lateral restraint that permits rotation

6.9

slenderness ratio

ratio of the effective height to the effective thickness

6.10 Strength of masonry

6.10.1

compressive strength

strength of masonry in compression, without the effects of platen restraint or slenderness

6.10.2

design strength

characteristic strength of masonry divided by the appropriate partial safety factor for materials

6.10.3

flexural strength

strength of masonry in bending without the effects of edge restraint

6.10.4**shear strength**

strength of masonry subjected to equal and opposite parallel forces that tend to displace, or produce relative sliding of, adjacent planes

6.10.5**tensile strength**

strength of masonry subjected to direct tensile forces

6.11 Strength of masonry units**6.11.1****crushing strength**

failure load under compression of a single specimen divided by its loaded area

6.11.2**compressive strength**

mean crushing strength of a sample of a specified number of masonry units

6.11.3**normalized compressive strength**

f_b
compressive strength of masonry units modified to the air-dried strength of an equivalent 100 mm wide × 100 mm high masonry unit

6.12 Strength of mortar**6.12.1****compressive strength**

mean crushing strength of a specified number of mortar specimens after curing for 28 days

6.12.2**site compressive strength**

compressive strength of mortar specimens made from samples of fresh mortar taken from the site

6.13**support**

means of carrying vertical load

SEE also **restraint** (6.8)

6.14 Thickness**6.14.1****effective thickness**

figure used in structural calculations to represent the thickness of a wall, pier or column used in calculating the slenderness ratio

6.14.2**thickness of masonry**

thickness based on the work size of the units

7 Structural components**7.1****column**

slender structural member, usually vertical, that transmits to its base the forces, primarily in compression, that are applied to it

7.2 Masonry

7.2.1

unreinforced masonry

assemblage of units laid in a specified pattern and joined together with mortar

7.2.2

reinforced masonry

masonry in which bars or mesh, usually of steel, are embedded in mortar or grout so that all the materials act together in resisting forces

7.2.3

prestressed masonry

masonry in which internal stresses have been induced, usually by means of steel

7.3

masonry bond

disposition of units in masonry to form a regular pattern

7.4 Masonry panels

7.4.1

confined masonry

masonry built rigidly between structural columns and beams on all four sides

7.4.2

infill panel

masonry restrained on at least two sides and which is not designed to resist vertical load other than its own weight

7.5

peripheral tie ring anchor US

tie incorporated into the floor or beam elements around the periphery of a building capable of transmitting loads continuously over the whole length of the perimeter

7.6

pier pilaster US

integral part of a wall, in the form of thickened sections placed at intervals along the wall

7.7

ring beam

horizontal beam around the structure tying it together at that level, capable of transmitting horizontal forces in bending

7.8 Wall

7.8.1

bracing wall buttressing wall stiffening wall

wall set at right angles to another to give it support against lateral forces

7.8.2

cavity wall

two parallel single-leaf walls, usually at least 50 mm apart, and effectively tied together with wall ties, the space between being left as a continuous cavity or filled with non-load-bearing material

7.8.3**double-leaf wall**

collar-jointed wall (deprecated)

two parallel leaves with the space between (not exceeding 25 mm) filled solidly with mortar and tied together so as to result in common action under load

7.8.4**faced wall**

wall in which the facing and backing are bonded so as to result in common action under load

7.8.5**grouted cavity wall**

two parallel single-leaf walls, spaced at least 50 mm apart, securely tied together with wall ties and with the intervening cavity filled with grout so as to result in common action under load

7.8.6**load-bearing wall**

wall primarily designed to carry an imposed load in addition to its own weight

7.8.7**panel**

wall not subject to significant vertical load, usually subject to significant wind loading

7.8.8**pocket-type retaining wall**

reinforced masonry wall with the main reinforcement in concrete-filled vertical pockets formed in the tension face of the masonry

7.8.9**shear wall**

wall to resist in-plane lateral forces

7.8.10**single-leaf wall**

wall without cavity or continuous vertical joint in its plane

7.8.11**wallette**

small wall constructed for test purposes

8 Miscellaneous terms**8.1****chase**

channel cut in masonry to accommodate pipes, ducts, etc.

8.2**recess**

indentation in a face of the wall

9 Test methods and equipment**9.1****air-dried condition**

moisture content achieved by prolonged exposure to ambient conditions in a laboratory

9.2

capping

material applied to the surfaces of a specimen to make them plane and parallel

EXAMPLE Mortar or gypsum.

9.3 Platens

9.3.1

auxiliary platens

separate plates of substantial and specified thickness attached to the platens

9.4

reference test

test specified sufficiently precisely to enable different laboratories to achieve comparable results and to ensure reliable data for design purposes

10 Dimensions and mass

10.1 Area

10.1.1

gross area

area of a section through a unit including the areas of any holes, voids and re-entrants

10.1.2

loaded area

area over which the load is applied

10.1.3

net area

mean area of the cross-section of solid material of a unit or the gross area less the area of voids and re-entrants

10.2 Density of masonry units

10.2.1

gross density

mass per unit gross volume

10.2.2

net density

mass per unit net volume of the solid material (excluding the volume of holes and indentations)

10.2.3

density

{powders and wet mortar} mass per unit volume

10.3 Volume of masonry units

10.3.1

gross volume

{for units in which holes pass right through} gross area multiplied by the mean height

10.3.2

net volume

net area multiplied by the mean height

10.3.3**net volume**

(for units with cells or frogs) gross volume of the unit less the measured volume of the voids

11 Water-related properties**11.1 Masonry units****11.1.1****suction rate****initial rate of absorption US**

average rate, measured over 1 min, starting from the first contact, at which the bed face of the masonry unit absorbs water at ambient temperature

NOTE The suction rate is expressed as a mass per unit area of the gross area of the bed face per unit time. However, the initial rate of absorption is based upon the net area of the bed face.

11.1.2**water absorption**

amount of water, as a proportion of the dry weight of the unit, absorbed under prescribed conditions

11.2 Mortar**11.2.1****consistence**

degree of firmness with which the particles of a concrete mortar, or grout cohere

11.2.2**flow**

measure of the consistence of freshly mixed concrete, mortar or grout

11.2.3**water retentivity**

ability of mortar to retain its moisture under suction from a masonry unit

Bibliography

- [1] ISO 7345:1987, *Thermal insulation — Physical quantities and definitions.*
- [2] ISO 9652-2:—³⁾, *Masonry — Part 2: Unreinforced masonry design by simple rules.*
- [3] ISO 9652-3:—³⁾, *Masonry — Part 3: Reinforced masonry design by calculation.*
- [4] ISO 9652-4: —³⁾, *Masonry — Part 4: Test methods.*
- [5] ISO/IEC Guide 52, *Glossary of fire terms and definitions.*

3) To be published.

Index

- A**
- accidental eccentricity 6.1.1
 - accidental load 6.5.1
 - actual size 3.5.3
 - addition 4.1
 - admixture 4.2
 - air-dried condition 9.1
 - area 10.1
 - autoclaved aerated concrete unit 3.2.3.1
 - auxiliary platens 9.3.1
 - axial loading 6.6.1
- B**
- bed joint 4.10.3
 - binder 4.3
 - bracing wall 7.8.1
 - buttressing wall 7.8.1
- C**
- calcium silicate unit 3.2.1
 - capping 9.2
 - cavity wall 7.8.2
 - cells 3.4.1
 - characteristic dead load 6.5.3
 - characteristic imposed or wind load 6.5.6
 - chase 8.1
 - clay unit 3.2.2
 - clear height 6.2.1
 - collar joint 4.10.4
 - collar-jointed wall (deprecated) 7.8.3
 - column 7.1
 - compressive strength 6.10.1, 6.11.2, 6.12.1
 - concentric loading 6.6.2
 - concrete units 3.2.3
 - confined masonry 7.4.1
 - connector 5.1
 - consistence 11.2.1
 - control joint 6.7
 - coordinating size 3.5.1
 - cross joint 4.10.5
 - crushing strength 6.11.1
- D**
- damp-proof course 5.2
 - dead load 6.5.2
 - dense-aggregate concrete unit 3.2.3.2
 - density of masonry units 10.2
 - density 10.2.3
 - design strength 6.10.2
 - double-leaf wall 7.8.3
- dpc** 5.2
- dressed stone unit** 3.2.4.1
- E**
- eccentric loading 6.6.3
 - eccentricity 6.1
 - effective height 6.2.2
 - effective thickness 6.14.1
 - effective width 6.4
- F**
- face-shell bedding 4.5
 - face shell 3.4.8
 - faced wall 7.8.4
 - factory-made mortar 4.8.2
 - f_b 6.11.3
 - fixed restraint 6.8.3
 - flexural strength 6.10.3
 - flow 11.2.2
 - frog 3.4.2
- G**
- galvanized steel 5.5.1
 - grip-hole 3.4.3
 - gross area 10.1.1
 - gross density 10.2.1
 - gross volume 10.3.1
 - group 2 unit 3.3.2
 - group 3 unit 3.3.3
 - group 1 unit 3.3.1
 - grout 4.6
 - grouted cavity wall 7.8.5
- H**
- hand-held 3.4.3
 - head joint 4.10.6
 - height 6.2
 - hole core US 3.4.4
 - hydrated lime 4.7.1
 - hydraulic lime 4.7.3
- I**
- imposed load 6.5.4
 - infill panel 7.4.2
 - initial rate of absorption US 11.1.1
- J**
- jointing 4.10.1
 - joist hanger 5.3
- L**
- lateral loading 6.6.4
 - lateral restraint 6.8.1
 - lateral restraint 6.8.2
 - lightweight mortar 4.8.1
 - lightweight-aggregate concrete unit 3.2.3.3
 - lime putty 4.7.2
 - lime 4.7
 - lintel 5.4
 - load 6.5
 - load-bearing wall 7.8.6
 - loaded area 10.1.2
 - loading conditions 6.6
 - low-carbon steel 5.5.2
- M**
- manufactured stone unit 3.2.4.2
 - masonry 7.2
 - masonry bond 7.3
 - masonry cement 4.4
 - masonry panels 7.4
 - masonry unit 3.1
 - masonry units 11.1
 - mortar bond 4.9
 - mortar joints 4.10
 - mortar 11.2
 - mortar 4.8
 - movement joint 6.7
- N**
- net area 10.1.3
 - net density 10.2.2
 - net volume 10.3.2, 10.3.3
 - nominal size (deprecated) 3.5.1
 - normalized compressive strength 6.11.3
- P**
- panel 7.8.7
 - peripheral tie 7.5
 - perpend 4.10.6
 - pier 7.6
 - pilaster US 7.6
 - platens 9.3
 - pocket-type retaining wall 7.8.8
 - pointing 4.10.2
 - prestressed masonry 7.2.3
- R**
- ready-mixed mortar 4.8.3
 - ready-to-use mortar 4.8.4
 - recess 8.2
 - reference test 9.4

reinforced masonry 7.2.2
restraint 6.8
ring anchor US 7.5
ring beam 7.7

S

shear strength 6.10.4
shear wall 7.8.9
shell 3.4.7
simple restraint 6.8.4
single-leaf wall 7.8.10
site compressive strength 6.12.2
slenderness ratio 6.9
stainless steel 5.5.3
steel 5.5
stiffened section 6.3
stiffening wall 7.8.1

stone units 3.2.4
storey height 6.2.3
strap 5.5.4
strength of masonry units 6.11
strength of masonry 6.10
strength of mortar 6.12
structural eccentricity 6.1.2
suction rate 11.1.1
support 6.13

T

tensile strength 6.10.5
thickness of masonry 6.14.2
thickness 6.14
thin-layer joint 4.10.7
thin-layer mortar 4.8.5
tie 5.5.4

U

unreinforced masonry 7.2.1

V

void 3.4.5
volume of masonry units 10.3

W

wall tie 5.5.5
wall 7.8
walette 7.8.11
water absorption 11.1.2
water retentivity 11.2.3
web 3.4.6
wind load 6.5.5
work size 3.5.2

ICS 91.080.30

Price based on 18 pages

© ISO 2000 – All rights reserved