

INTERNATIONAL STANDARD

ISO
9652-2

First edition
2000-04-01

Masonry —

Part 2: Unreinforced masonry design by simple rules

Maçonnerie —

*Partie 2: Conception de la maçonnerie non armée par des règles
simplifiées*

This material is reproduced from ISO documents under International Organization for Standardization (ISO) Copyright License Number HIS/CC/1996. Not for resale. No part of these ISO documents may be reproduced in any form, electronic retrieval system or otherwise, except as allowed in the copyright law of the country of use, or with the prior written consent of ISO (Case postale 56, 1211 Geneva 20, Switzerland Fax +41 22 734 10 79), IHS or the ISO Licensor's members.



Reference number
ISO 9652-2:2000(E)

© ISO 2000

ISO 9652-2:2000(E)**PDF disclaimer**

This PDF file may contain embedded typefaces. In accordance with Adobe's licensing policy, this file may be printed or viewed but shall not be edited unless the typefaces which are embedded are licensed to and installed on the computer performing the editing. In downloading this file, parties accept therein the responsibility of not infringing Adobe's licensing policy. The ISO Central Secretariat accepts no liability in this area.

Adobe is a trademark of Adobe Systems Incorporated.

Details of the software products used to create this PDF file can be found in the General Info relative to the file; the PDF-creation parameters were optimized for printing. Every care has been taken to ensure that the file is suitable for use by ISO member bodies. In the unlikely event that a problem relating to it is found, please inform the Central Secretariat at the address given below.

© ISO 2000

All rights reserved. Unless otherwise specified, no part of this publication may be reproduced or utilized in any form or by any means, electronic or mechanical, including photocopying and microfilm, without permission in writing from either ISO at the address below or ISO's member body in the country of the requester.

ISO copyright office
Case postale 56 • CH-1211 Geneva 20
Tel. + 41 22 749 01 11
Fax + 41 22 734 10 79
E-mail copyright@iso.ch
Web www.iso.ch

Printed in Switzerland

Contents

Page

Foreword	iv
Introduction	v
1 Scope	1
2 Normative references	2
3 Terms and definitions	3
4 Symbols	3
5 Stability and robustness	3
6 Limiting loads, strengths and dimensions	4
6.1 General	4
6.2 Limits in respect of walls (but see Table 1)	4
6.3 Limits on sizes of openings	5
6.4 Limits on positions of openings	6
7 Thickness of walls	7
7.1 External and separating walls	7
7.2 Internal walls	8
7.3 Basement walls	8
8 Rules for stiffening walls, piers and chimneys	9
8.1 General	9
8.2 Internal stiffening walls providing restraint	9
8.3 Piers and chimneys providing restraint	9
9 Walls subjected mainly to wind load	10
10 Non-loadbearing internal walls	15
11 Chases and recesses	15
Annex A (normative) Rules for seismic zones	17
Annex B (normative) External walls of certain small single-storey buildings and annexes	19

Foreword

ISO (the International Organization for Standardization) is a worldwide federation of national standards bodies (ISO member bodies). The work of preparing International Standards is normally carried out through ISO technical committees. Each member body interested in a subject for which a technical committee has been established has the right to be represented on that committee. International organizations, governmental and non-governmental, in liaison with ISO, also take part in the work. ISO collaborates closely with the International Electrotechnical Commission (IEC) on all matters of electrotechnical standardization.

International Standards are drafted in accordance with the rules given in the ISO/IEC Directives, Part 3.

Draft International Standards adopted by the technical committees are circulated to the member bodies for voting. Publication as an International Standard requires approval by at least 75 % of the member bodies casting a vote.

Attention is drawn to the possibility that some of the elements of this part of ISO 9652 may be the subject of patent rights. ISO shall not be held responsible for identifying any or all such patent rights.

International Standard ISO 9652-2 was prepared by Technical Committee ISO/TC 179, *Masonry*, Subcommittee SC 1, *Unreinforced masonry*.

ISO 9652 consists of the following parts, under the general title *Masonry*:

- *Part 1: Unreinforced masonry design by calculation*
- *Part 2: Unreinforced masonry design by simple rules*
- *Part 3: Reinforced masonry design by calculation*
- *Part 4: Test methods*
- *Part 5: Vocabulary*

Annexes A and B form a normative part of this part of ISO 9652.

Introduction

The rules in this part of ISO 9652 are intended to provide certain masonry designs without the need for structural calculations. ISO 9652-1 and some national standards will be more restrictive in certain circumstances.

Annex A gives additional rules for use in seismic zones. Annex B gives rules for certain small single-storey buildings and annexes.

Masonry —

Part 2: Unreinforced masonry design by simple rules

1 Scope

This part of ISO 9652 gives limited rules for the structural design and construction of unreinforced masonry for which calculations of loading and strength criteria are not required. This part of ISO 9652 is applicable to masonry built with Group 1, 2, or 3 masonry units [see 5.2.1 of ISO 9652-1:—] of clay, calcium silicate, concrete (including autoclaved aerated concrete), and manufactured stone units. The field of application is defined in Table 1 and is subject to the limitations of normative annex A.

NOTE Clauses 5, 6, 7 and 8 should be taken together; clauses 9 and 10 may be applied separately; clause 11 applies to all walls covered by this part of ISO 9652.

For masonry designed by calculation, see ISO 9652-1.

Table 1 — Field of application

Type of wall	Type of building	Location	Type of loading
Loadbearing	Low-rise dwelling of not more than two floor levels in addition to any basement	Sheltered coastal sites and inland sites except very exposed hills and crests	Vertical and wind loads (for limits see clause 6)
	Other small single-storey buildings		
Basement walls	All buildings	All sites	Earth pressure and vertical loads
External non-loadbearing	All buildings up to and including four storeys except low-rise dwellings of not more than two floor levels in addition to any basement	Site with many windbreaks, such as city, town or well-wooded areas	Wind load. No significant vertical load
Internal non-loadbearing	All buildings	Inside buildings without large openings	No significant vertical or wind loads

ISO 9652-2:2000(E)

The following are not covered by this part of ISO 9652:

- a) foundations as shown in Figure 1;
- b) free-standing walls;
- c) retaining walls other than basement walls;
- d) basement walls subjected to hydrostatic pressure;
- e) masonry in seismic areas with expected ground accelerations in excess of $1,0 \text{ m/s}^2$ (see normative annex A).

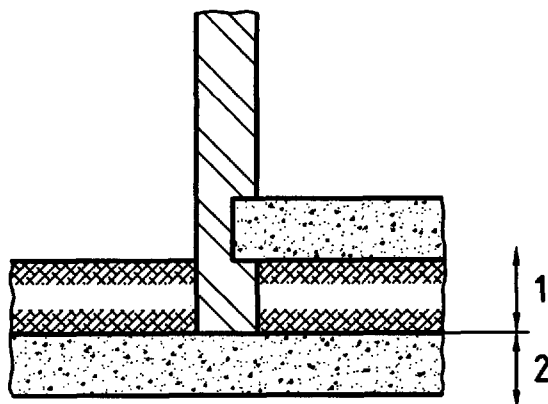
**Key**

- 1 Within scope
- 2 Outside scope

Figure 1 — Foundations

2 Normative references

The following normative documents contain provisions which, through reference in this text, constitute provisions of this part of ISO 9652. For dated references, subsequent amendments to, or revisions of, any of these publications do not apply. However, parties to agreements based on this part of ISO 9652 are encouraged to investigate the possibility of applying the most recent editions of the normative documents indicated below. For undated references, the latest edition of the normative document referred to applies. Members of ISO and IEC maintain registers of currently valid International Standards.

ISO 9652-1:—¹⁾, *Masonry — Part 1: Unreinforced masonry design by calculation.*

ISO 9652-3:—¹⁾, *Masonry — Part 3: Reinforced masonry design by calculation.*

ISO 9652-4:—¹⁾, *Masonry — Part 4: Test methods.*

ISO 9652-5:2000, *Masonry — Part 5: Vocabulary.*

1) To be published.

3 Terms and definitions

For the purposes of this part of ISO 9652, the terms and definitions given in ISO 9652-5 apply.

4 Symbols

A_o	Permitted area of opening, in square metres (m ²)
a_1, a_2, a_3	Lengths of wall between one opening and another or between an opening and a buttressing wall or pier
d	Maximum dimension of an opening (height or width) in a wall, which relates to the distance of the opening from the main restraints or roof
H	Height of a wall
h_u	Height of a masonry unit, in millimetres (mm)
h_t	Height of the ground above the basement floor
l or L	Length of a wall
l_1, l_2	Widths of openings in a wall
t	Wall thickness (whether of solid or cavity construction), in millimetres (mm)
t_1	Thickness of the outer leaf of a cavity wall, in millimetres (mm)
t_2	Thickness of the inner leaf of a cavity wall, in millimetres (mm)
t_a, t_b	Thickness of restraining wall and wall to be restrained respectively, in millimetres (mm)
u	Minimum overlap between the perpend in a course of masonry and the perpend in the course immediately above or below it, in millimetres (mm)
x	Depth of a chimney or pier (direction perpendicular to the plane of the wall), in millimetres (mm),
X	A factor which governs the relationship between the widths of openings in a wall and <ol style="list-style-type: none"> the lengths of wall between one opening and another, the lengths of wall between an opening and a buttressing wall or pier
y	Depth of a pier (direction perpendicular to the plane of the wall), in millimetres (mm).

5 Stability and robustness

For a robust and stable structure, it will be necessary to provide a layout of walls which will enable all lateral forces to be resisted in the two main directions. Such a design can be achieved most satisfactorily when the walls are arranged in a cellular form in which the loadbearing walls are provided with substantial returns, piers or chimneys. The connections between interacting walls and between walls, roofs or floors should be capable of transmitting lateral forces to the foundations; one way of achieving this is by the use of ring beams. The design should also ensure that any foreseeable negative loads, particularly suction loads on flat or shallow pitched-roof structures are resisted by suitable connections.

ISO 9652-2:2000(E)

Connections may be achieved by the bonding of masonry or, in some cases, by friction at floor and beam bearings on masonry. Alternatively, strong, durable, creep-resistant straps, ties, hangers, brackets and angles may be used as connections between walls and restraining walls and between walls and floors or roofs acting as buttresses. Ring beams at the head of each storey may also be used to provide horizontal supports.

6 Limiting loads, strengths and dimensions**6.1 General**

If loads, strengths or dimensions fall outside the limits given in this clause then calculations should be made for that part of the structure affected.

6.2 Limits in respect of walls (but see Table 1)

- 6.2.1** The imposed load on any roof, for example snow load, should not exceed 0,9 kN/m², excluding wind load.
- 6.2.2** The imposed load on any suspended floor, excluding the load from internal walls, should not exceed 2,0 kN/m².
- 6.2.3** The imposed load on any floor due to any internal walls should not exceed 1,2 kN/m².
- 6.2.4** The wind load, including internal and external pressures, should not exceed 1,2 kN/m².
- 6.2.5** Floors and roofs should not have a mass greater than 550 kg/m², including any screed or concrete topping.
- 6.2.6** The minimum normalized compressive strength of masonry units measured in accordance with ISO 9652-4 should be 4,0 N/mm² unless otherwise required by the rules (normative annex A and Table 2). If the minimum wall thickness of 100 mm is increased to 240 mm then the minimum normalized strength may be reduced to 3,0 N/mm². Linear interpolation is permitted. The minimum mortar class in accordance with ISO 9652-1 should be M2, except where the web thickness of units that have more than 50 % voids is 20 mm or less. In that case, the minimum mortar class should be M10.
- 6.2.7** The thickness of the loadbearing leaf of a cavity wall may be reduced to 90 mm provided that the minimum normalized compressive strength given in 6.2.6 is increased by 10 %.
- 6.2.8** The clear span of floors or concrete roof members should not exceed 6 m.
- 6.2.9** The clear span of timber roofs should not exceed 12 m when the reaction of the timber roof on the loadbearing leaf is sensibly axial, otherwise the clear span should not exceed 9 m.
- 6.2.10** The clear span of lintels over openings should not exceed 3 m (see Figure 2 and 6.3).
- 6.2.11** In the absence of calculations, the length of lintel bearings (see Figure 2) should be not less than the following for masonry built from units of Group 1:
- a) for timber floors spanning at right angles to the lintel, one tenth²⁾ of the length of the opening; or
 - b) for concrete floors spanning at right angles to the lintel, one sixth of the length of the opening
- but, in any case not less than 150 mm except where the length of masonry between openings is less than 300 mm in accordance with 6.3, when the bearing length should be not less than 120 mm and the bearing area should be not less than 15 000 mm².

2) For a single-leaf wall or the inner leaf of a cavity wall of thickness greater than 100 mm, the minimum length of bearing given here may be multiplied by the ratio: 100 / leaf thickness (in millimetres)

For masonry built from units of Groups 2 or 3, the length of lintel bearing shown above should be increased by 1/3.

6.2.12 The bearing for floors spanning on walls should be not less than 85 mm.

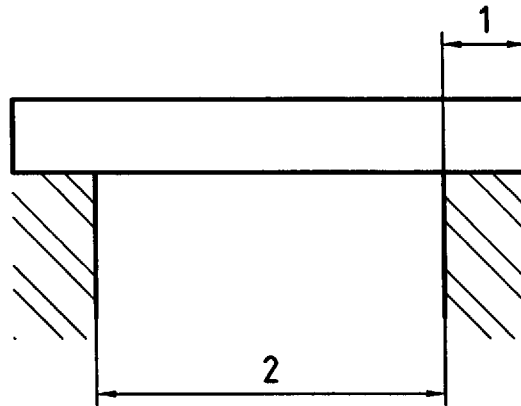

Key

- 1 Bearing length (see 6.2.11 and 6.2.12)
- 2 Opening (see 6.2.10)

Figure 2 — Length of lintel bearing

6.2.13 For single-leaf construction, masonry units should have a normalized compressive strength equal to or greater than that for the inner leaf of a cavity wall in the same position.

6.2.14 To ensure adequate bonding, masonry units should overlap by a length of at least $0,4 \times$ the height of the unit when looking at the face of the wall, or 45 mm, whichever is the greatest (see Figure 3).

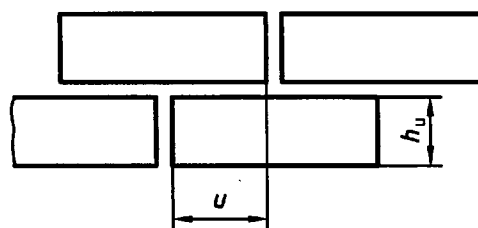

Key

- u Minimum overlap which should be greater than or equal to $0,4 h$ and greater than or equal to 45 mm
- h Height of a masonry unit, in millimetres

Figure 3 — Bonding of units; minimum overlap

6.3 Limits on sizes of openings

The sizes of openings should be determined in accordance with the following rules:

- $l_1 + l_2$ should not exceed $\frac{2l}{3}$
- l_1 or l_2 should not exceed 3 m

- a_1 should be greater than or equal to $\frac{l_1}{X}$
- a_2 should be greater than or equal to $\frac{l_1 + l_2}{X}$
- a_3 should be greater than or equal to $\frac{l_2}{X}$

where a and l are shown in Figure 4, and X is a factor taken from Table 2.

a_1 , a_2 and a_3 should be not less than 1½ units in length for Group 2 units having more than 50 % voids or for Group 3 units. More than two openings are permitted in a wall, provided that they meet the principles of the criteria above.

6.4 Limits on positions of openings

Where the wall acts as a lateral restraint, any opening, other than openings having an area less than 0,1 m², should be not less than 550 mm from the wall junction.

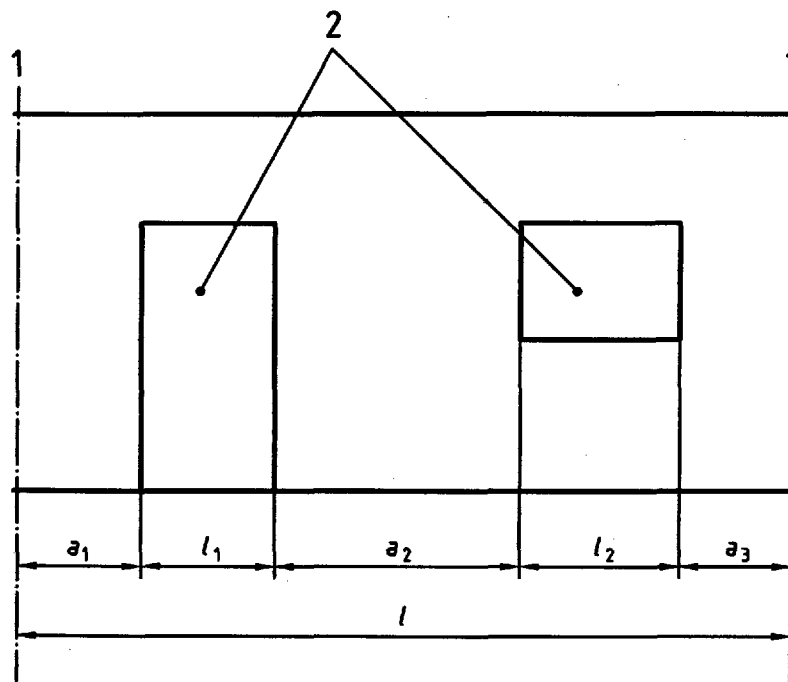

Key

- 1 Centre-line of buttressing wall or pier
- 2 Opening

Figure 4 — Sizes of openings

Tableau 2 — Value of factor X (see 6.3 and Figure 4)

Nature of roof	Maximum roof span m	Minimum thickness of wall or loadbearing leaf of a cavity wall mm	Span of floor parallel to wall	Span of timber floor into wall		Span of floors, other than timber, of maximum mass 550 kg/m ²	
				max. 4,5 m	max. 6,0 m	max. 4,5 m	max. 6,0 m
Value of factor X							
Roofs spans parallel to wall	not applicable	100	6	6	6	6	6
		> 100	See note 1				
Timber roof spans onto wall	12	100	6	6	5 (see note 2)	4 (see note 2)	3 (see note 2)
		> 100	See note 1				
Roof, other than timber, of maximum mass 550 kg/m ² spans onto wall		100	6	6	6	6 (see note 3)	6 (see note 3)
		> 100	See note 1				

NOTE 1 If the wall or loadbearing leaf is thicker than 100 mm, the value of factor X may be divided by the ratio of 100/the wall thickness, that is to give the equivalent plan area, provided that the length of masonry is never less than the length of a whole masonry unit.

NOTE 2 The value of factor X may be increased to 6, provided that the normalized compressive strength of the masonry units in the wall (or loaded leaf of a cavity wall) is not less than 10 N/mm².

NOTE 3 The lower storey of two-storey buildings should be constructed of masonry units of minimum normalized compressive strength of 10 N/mm².

7 Thickness of walls

7.1 External and separating walls

7.1.1 Loadbearing single-leaf walls

The minimum thickness in relation to the interval of restraint of external loadbearing and separating single-leaf masonry walls should be as given in column 1 of Table 3.

Table 3 — Minimum thickness of external and separating single-leaf walls

Minimum thickness of loadbearing wall mm	Maximum clear height m	Maximum interval between lateral restraints m
150	2,8	6,0
225	3,5	8,0

NOTE Interpolation is permitted.

7.1.2 Loadbearing cavity walls

Where the load is carried entirely on one leaf which is stiffened by another leaf of not less than 100 mm in thickness and the two leaves are connected by wall ties, the minimum thickness of the loadbearing leaf and the spacing of wall ties should be as given in Table 4. In other cases, the minimum thickness should be as given in Table 3. For separating walls between dwellings, wall ties are only necessary at floor and ceiling levels.

Table 4 — Minimum thickness of loadbearing leaf of cavity walls and wall-tie spacing

Minimum thickness of loadbearing leaf mm	Maximum clear height m	Maximum interval between lateral restraints m	Spacing of ties(see note)		Minimum number of ties per m ²
			Horizontal m	Vertical m	
90	2,75	9,0	≤ 1,0	≤ 0,5	≥ 2,5
140	3	9,0	≤ 1,0	≤ 0,5	≥ 2,5

NOTE Additional wall ties should be provided within 300 mm of all openings and adjacent to the unreturned edges of panels so that there is one for each 300 mm of height.

7.2 Internal walls

7.2.1 Loadbearing internal single-leaf walls

The thickness of a loadbearing internal single-leaf wall with lateral restraint at the top of each storey should be not less than 1/27 of the storey height between horizontal lateral restraints, but never less than 90 mm. Walls of height greater than 1 m below ground-floor level of a two-storey building should be not less than 140 mm thick.

7.3 Basement walls

The rules for basement walls, given below, apply only if

- a) the clear height of the basement wall is not greater than 2,60 m,
- b) the basement wall supports a concrete or masonry floor of minimum mass 300 kg/m² and a minimum span of 4 m which provides adequate lateral restraint,
- c) the basement wall supports a further floor or a roof of minimum mass 300 kg/m² and a minimum span of 4 m,
- d) the ground surface adjacent to the wall is sensibly level and is not subjected to any imposed loading and deadloading exceeding 5 kN/m²,
- e) the minimum wall thickness in relation to the height of the ground above the basement floor is as given in Figure 5, and
- f) the wall is not subject to hydrostatic pressure.

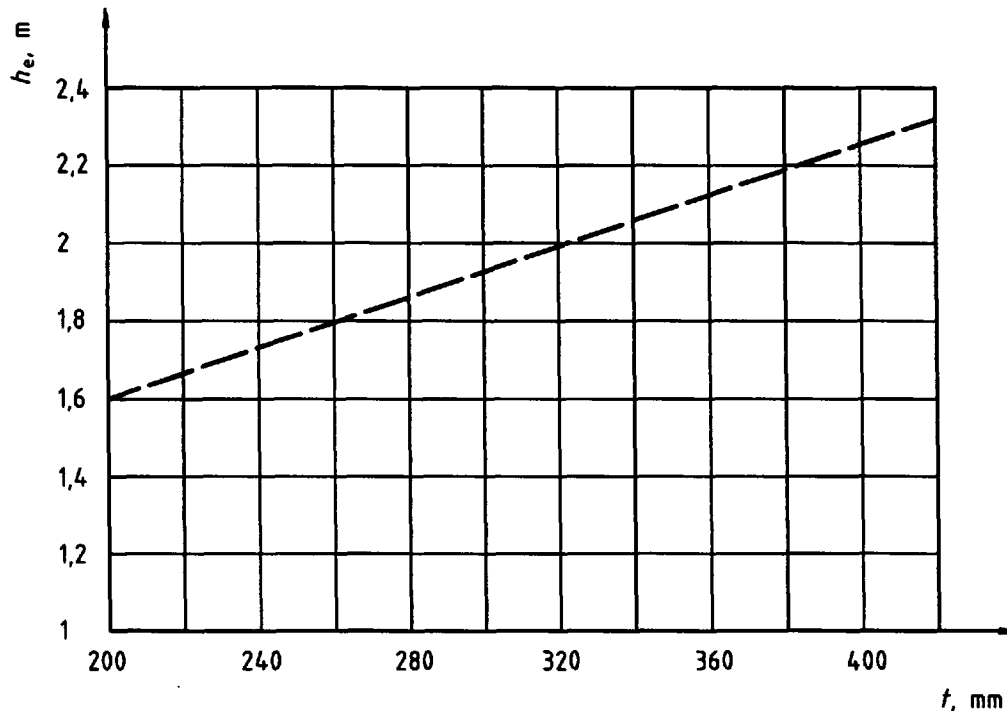

Figure 5 — Minimum basement wall thickness (t , in millimetres) in relation to height of ground (h_e , in metres) above the basement floor

8 Rules for stiffening walls, piers and chimneys

8.1 General

The ends of every loadbearing wall should be bonded or otherwise securely tied throughout the full height of the wall to a stiffening wall, pier or chimney. Walls whose length exceeds the maximum interval between lateral restraints given in Table 3, may be subdivided by stiffening walls, piers or chimneys, which should then provide restraint for the full height of the restrained wall.

8.2 Internal stiffening walls providing restraint

The stiffening wall should be bonded or securely tied to the wall, or loadbearing leaf of a cavity wall, which it is restraining. The other end of the stiffening wall should also be bonded or securely tied to a stiffening wall, pier or chimney. In the case of a connection between a loadbearing wall on foundations and a non-loadbearing wall supported on a ground-bearing slab, it is preferable to tie, not bond, the walls to reduce the risk of cracking due to differential vertical movement. The position and size of openings or recesses in a stiffening wall should not impair the vertical restraint which is provided by the stiffening wall (see Figure 6). In dwelling houses, a non-loadbearing masonry wall of thickness not less than 90 mm may be used as a stiffening wall to provide restraint to other walls.

8.3 Piers and chimneys providing restraint

Piers should be at least 3 times the required masonry thickness of the restrained wall, and chimneys should be at least twice the required thickness, measured at right angles to the wall. Piers should have a minimum width of 190 mm (see Figure 7).

The sectional area on plan of chimneys (excluding openings for fireplaces and flues) should be not less than the area required for a pier in the same wall, and the overall thickness should be not less than twice the required masonry thickness of the restrained wall (see Figure 7).

The masonry thickness is the overall thickness in the case of a single-leaf wall and the sum of the thicknesses of the leaves of a cavity wall.

9 Walls subjected mainly to wind load

For buildings other than low-rise dwellings of not more than two floor levels in addition to any basement with a storey height not greater than 3,5 m, the maximum area of an external masonry wall subjected mainly to wind load should be as given in Table 5.

Fixed restraints should be assumed only when the conditions shown in Figure 8 are satisfied.

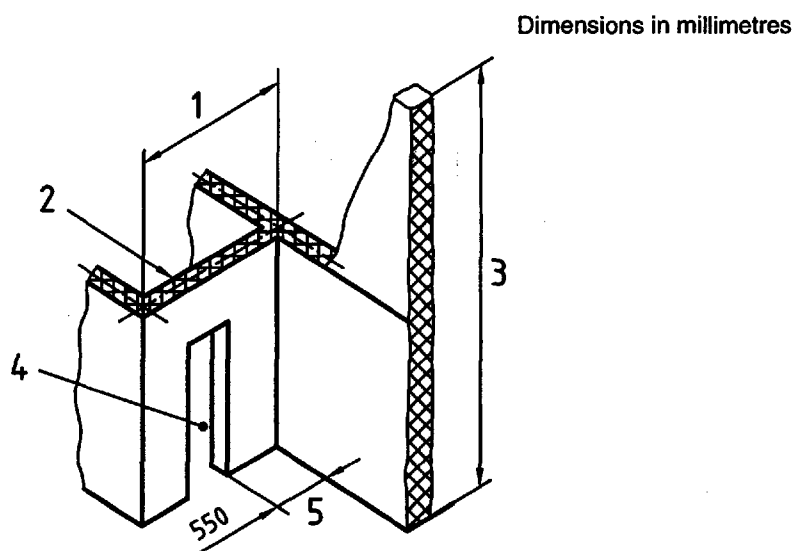

Key

- 1 The length of the stiffening wall should be at least $1/6$ of the overall height of the restrained wall.
- 2 Stiffening wall
- 3 Height of restrained wall
- 4 The opening height should be not more than 0,9 times the floor to ceiling height, and the depth of the lintel including any masonry over the opening should be not less than 150 mm.
- 5 An opening or recess should be at least 550 mm from the restrained wall with the exception of small holes for services etc. which should be limited to a maximum aggregate area of 0,1 m².

Figure 6 — Internal stiffening walls

Dimensions in millimetres

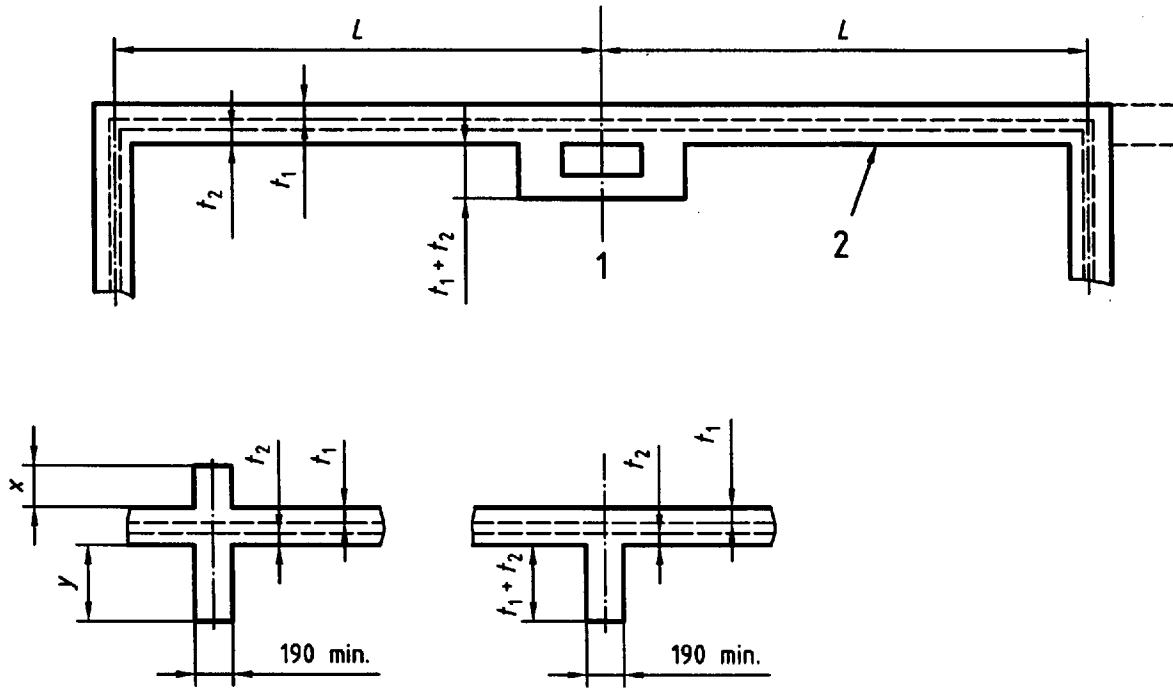

$$(x + y)_{\min} = 2(t_1 + t_2)$$

Key

- 1 Centre-line of chimney
- 2 Restrained wall (cavity or solid)

Figure 7 — Sizes of stiffening chimneys and piers

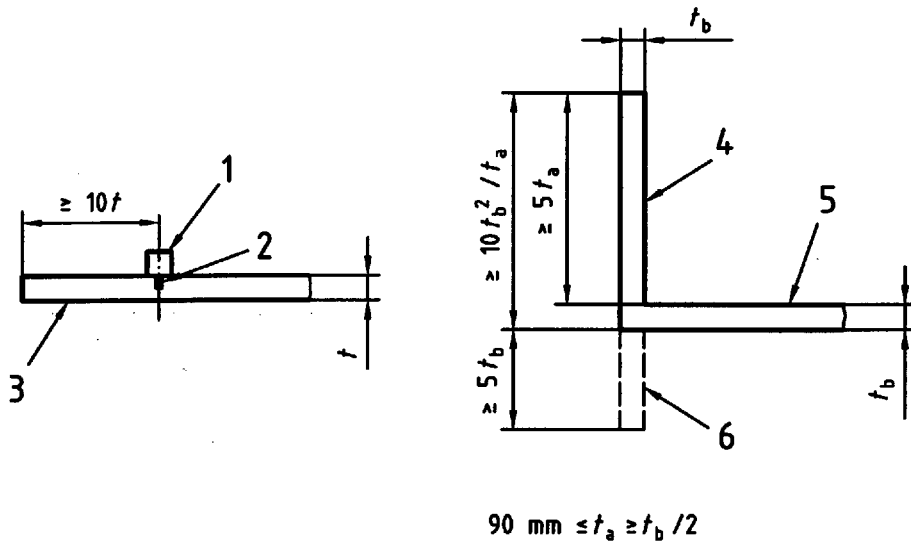

Key

- 1 Column or pier
- 2 Tie
- 3 Wall to be restrained
- 4 Restraining wall one side only
- 5 Wall to be restrained
- 6 Restraining wall both sides

a) Solid walls

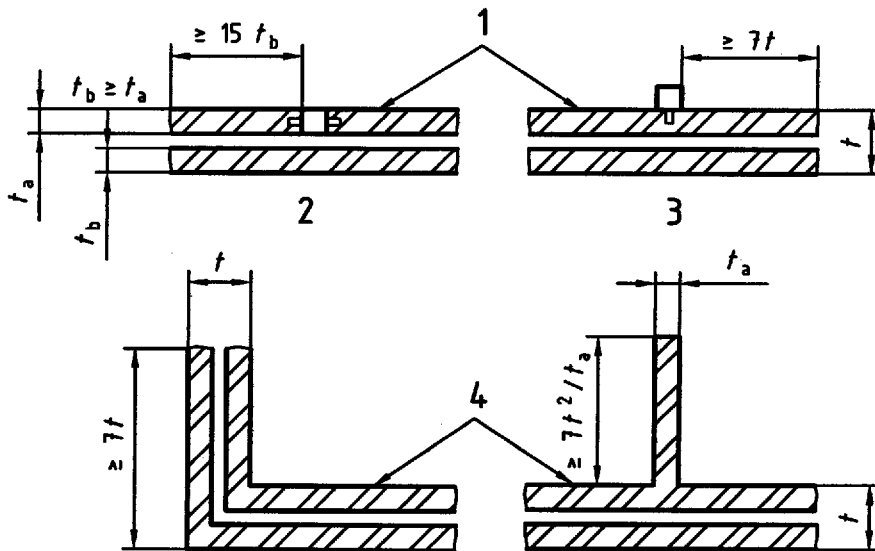

Key

- 1 Wall to be restrained
- 2 Inner leaf abuts and is tied to column
- 3 Both leaves pass column
- 4 Wall to be restrained

b) Cavity walls

NOTE Walls should continue without openings for distances shown to provide fixity to adjacent walls.

Figure 8 — Fixed restraint conditions

Tableau 5 — Maximum area of external walls subjected mainly to wind load

Type of wall	Maximum area of wall with fixed restraint on three sides and no restraint at the top m ²	Maximum area of wall with simple restraint on three sides and no restraint at the top m ²	Maximum area of wall with fixed restraint on four sides m ²	Maximum area of wall with simple restraint on four sides m ²
Single-leaf wall 110 mm thick ^a	—	—	16	8
Single-leaf wall 150 mm thick ^a	15	9	30	15
Single-leaf wall 225 mm thick ^a	22	13	44	24
Cavity wall ^b with one leaf 100 mm thick and the other leaf 90 mm thick	15	9	30	15
Cavity wall ^b with one leaf 140 mm thick and the other leaf 90 mm thick	18	11	36	18

^a Interpolation is permitted.

^b These are minimum thicknesses of the two leaves. One or the other leaf may be thicker.

The walls should not contain any doors, windows or other openings, unless either

- a) intermediate restraints are provided, such as those shown in Figure 9 a), or
- b) the total area of such openings is not greater than 10 % of the appropriate maximum area given in Table 5 or 25 % of the actual area of the wall, whichever is less, and no opening is less than half its maximum dimension from the edge of the wall, other than its base, or from any other opening [see figure 9 b)].

In a single-leaf wall, the distance between restraints should not exceed 40 times the total thickness of the wall.

In a cavity wall:

- the distance between restraints should not exceed 30 times the total thickness of the masonry in the wall;
- the thickness of one leaf should be not less than 100 mm and the thickness of the other leaf should be not less than 90 mm, excluding plaster or render;
- the cavity width should not exceed 150 mm;
- wall ties should be spaced in accordance with Table 4.

Pitched-roof gable walls which have restraint at the top should be regarded as being equivalent to a rectangular area whose height is measured to halfway up the triangular portion [see Figure 9 c)]. Three-sided or four-sided restraint should be assumed to be appropriate.

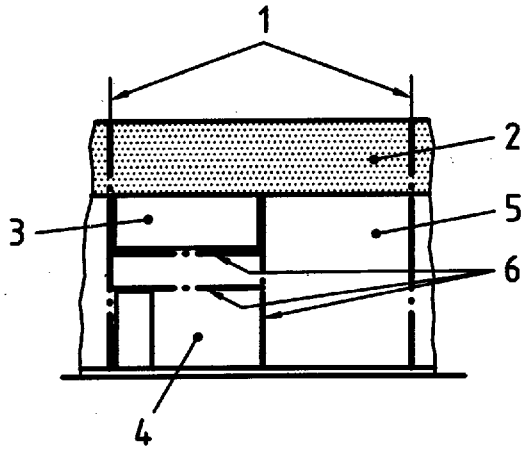

Key

- 1 Main restraints
- 2 Roof
- 3 Panel 1
- 4 Panel 2
- 5 Panel 3
- 6 Intermediate supports

a) Example of division of a wall into panels with intermediate restraint

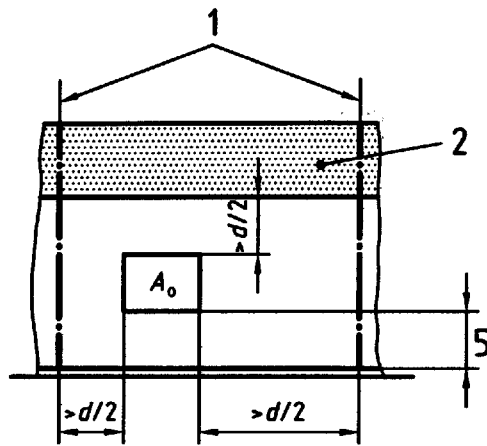

Key

- 1 Main restraints
- 2 Roof
- 3 No limit

b) Effect of opening in a wall

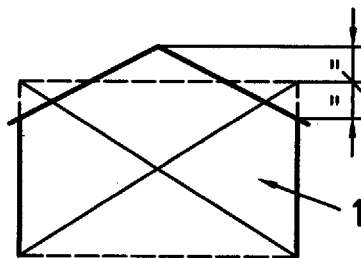

Key

- 1 Equivalent rectangular panel

c) Pitched-roof gable walls

Figure 9 — Walls with edge restraint

10 Non-loadbearing internal walls

The rules for non-loadbearing internal walls given in this clause apply only if:

- a) the walls will not be affected adversely by deflection of floors;
- b) where lateral restraint is needed at the top, it is provided, for example, by the frictional resistance of a mortar joint or alternatively by metal angles fixed to the floor;
- c) where adequate lateral restraint is needed at an end, it is provided, for example, by masonry bonding or suitable metal ties.

The size of the wall should be limited to that which results from the use of Figure 10 a), 10 b), 10 c) or 10 d), depending on the restraint condition, where H is the height of the wall, L is the length of the wall and t is the thickness of the wall. Notwithstanding the figures obtained, H should be not greater than 6 m and L not greater than 12 m. The thickness, t , may include the thickness of the plaster.

The minimum thickness should be 50 mm excluding the thickness of the plaster.

11 Chases and recesses

Chases should be kept to a minimum and not be so positioned as to impair stability of the wall, particularly where Group 2 or Group 3 units are used. Where such units are used, not less than 15 mm of material should be retained between the void and the back of the chase.

Vertical chases and recesses, not wider than 300 mm, should be not deeper than 30 mm.

Horizontal and diagonal chases should be avoided if possible, but in any case should be not deeper than 15 mm and be positioned not further than 1/8th of the storey height above or below the floor level.

When recesses wider than 300 mm and/or deeper than 30 mm are required, they should be treated as openings and sized in accordance with 6.3.

The sum of the widths of all chases and recesses should not exceed 1/4 of the length of the wall.

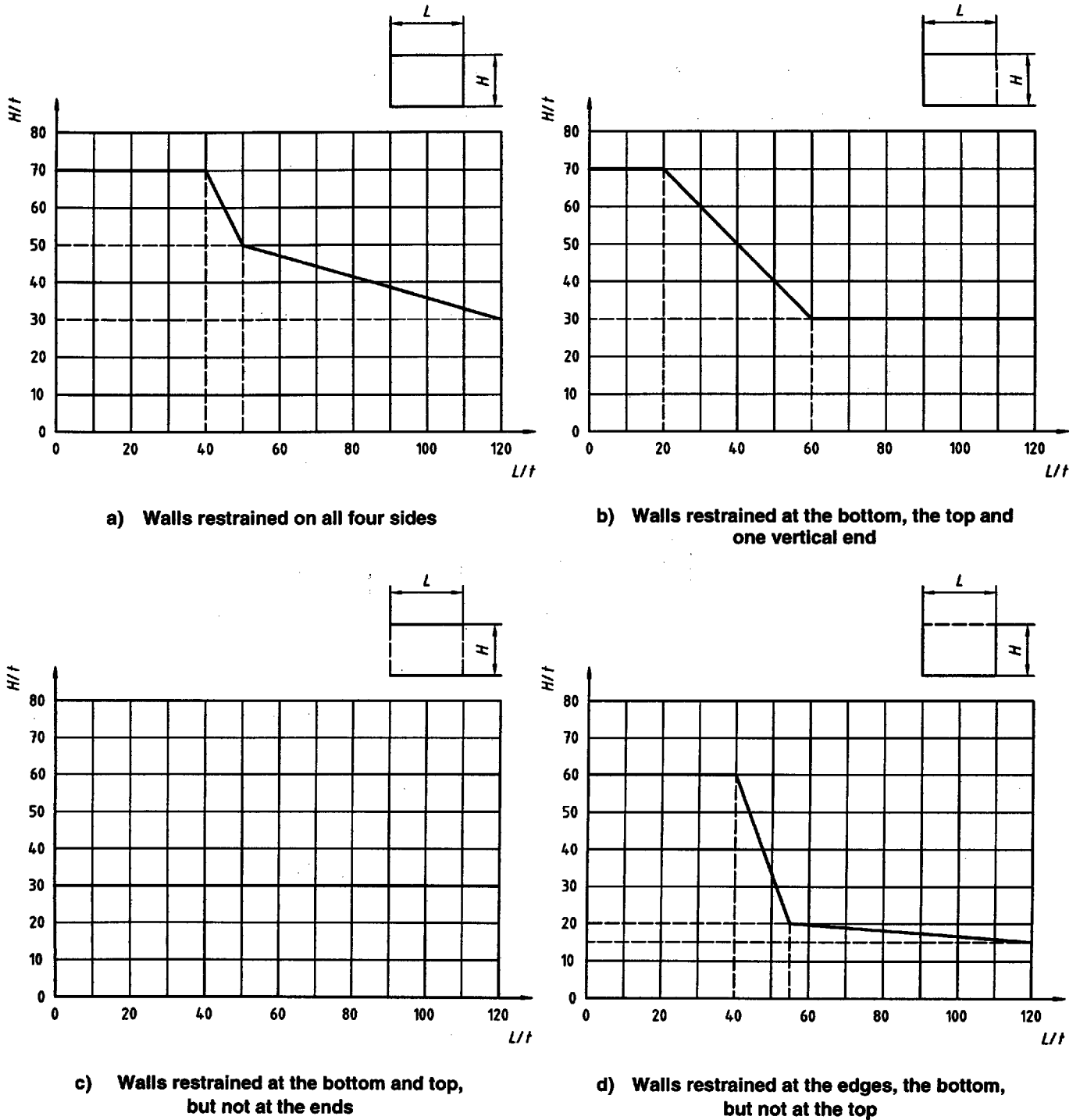

Figure 10 — Limiting height and length to thickness ratios of non-loadbearing internal walls for stability

Annex A (normative)

Rules for seismic zones

A.1 General

It would be uneconomical to design buildings with protection against destructive earthquakes using a "no significant damage" criterion. Generally, the aim should be to prevent major failures and loss of life.

A.2 Ground accelerations not exceeding $0,65 \text{ m/s}^2$

In seismic areas with ground accelerations not exceeding $0,65 \text{ m/s}^2$, the rules in this part of ISO 9652 can be applied without any additions.

A.3 Ground accelerations from $0,65 \text{ m/s}^2$ to $1,0 \text{ m/s}^2$

A.3.1 In seismic areas with ground accelerations from $0,65 \text{ m/s}^2$ to $1,0 \text{ m/s}^2$ the rules in this part of ISO 9652 should be applied with the following additions.

- a) The maximum interval between stiffening walls should be 5 m.
- b) Group 1 units only should be used.
- c) The minimum normalized compressive strength of masonry units should be 10 N/mm^2 .
- d) The minimum mortar class should be M10.
- e) The maximum storey height should be 3 m.
- f) The minimum thickness of wall should be 200 mm.
- g) The minimum length of wall between openings and the minimum length of wall between the centre of supporting wall and the edge of opening should be 500 mm.
- h) The distance between an opening in an internal wall and any part of another wall should not be less than twice the thickness of the internal wall.
- i) The roofs and floors should be of reinforced concrete or there should be a reinforced concrete ringbeam at the top of each storey.
- j) All floor and roof diaphragms should be well anchored to their supporting walls.
- k) The building should be divided into independent parts separated by unfilled joints of width up to 50 mm. The centre of mass of the independent parts should be as close as possible to the centre of rotation.
- l) The sum of the widths of the openings should be not greater than one-half the wall length in any direction, and not more than one-third of the total perimeter length.
- m) The independent parts should be symmetrical in plan.

A.4 Ground accelerations greater than 1,0 m/s²

In seismic areas with ground accelerations greater than 1,0 m/s², the rules given in this part of ISO 9652 cannot be used and masonry buildings should be designed in accordance with ISO 9652-3.

Annex B (normative)

External walls of certain small single-storey buildings and annexes

NOTE National building codes may restrict occupancy of certain buildings.

Single-leaf external walls which are

- a) constructed in masonry as given in clause 1,
- b) not subject to any load other than wind load and the distributed load of the roof of the small building or annex,
- c) in a building with an area of less than 36 m², and
- d) at least 90 mm thick,

should be of the proportions shown in Figure B.1.

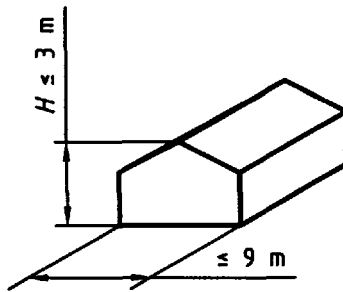

a) Small single-storey buildings (including detached garages)

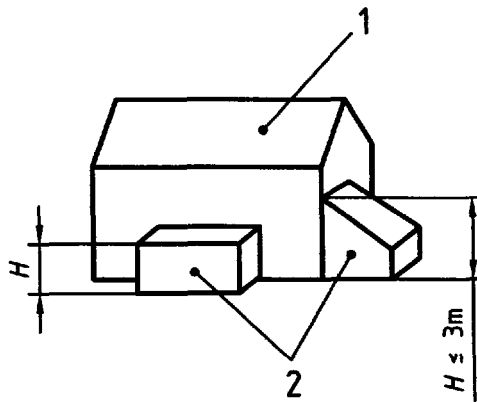

b) Annexes

Key

- 1 Building
- 2 Annexes

Figure B.1 — Size and shape of annexes and single-storey detached buildings

ISO 9652-2:2000(E)

Where such single-leaf masonry walls are greater than 2,5 m in length or height, they should be bonded or tied to stiffening walls or piers at intermediate points and at each end (see Figure B.2). Where ties are used to bond piers to walls, durable metal ties should be placed at not greater than 450 mm vertically from the centres. Piers should be such as to ensure the stability of the restrained wall, but not less than the size or spacing shown in Figure B.2.

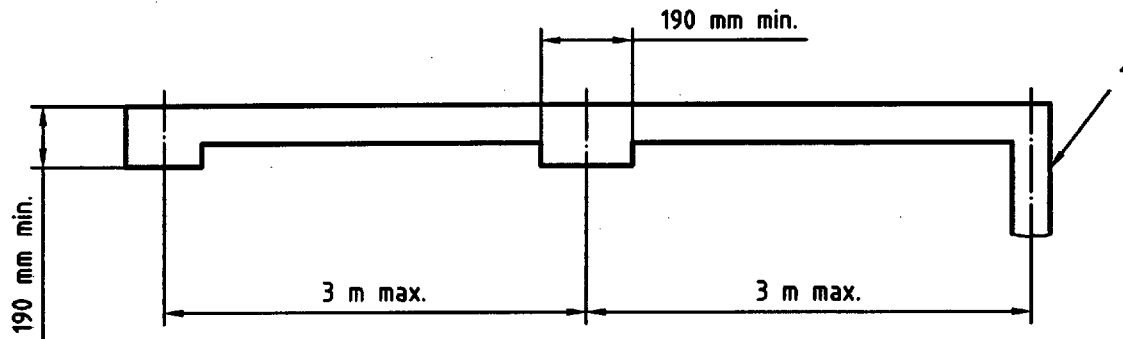

Key

- 1 Buttressing wall

Figure B.2 — Size and spacing of piers in annexes and single-storey detached buildings

ISO 9652-2:2000(E)

ICS 91.080.30

Price based on 20 pages

© ISO 2000 – All rights reserved