Small craft — Inflatable liferafts —
Part 3:
Materials

Petits navires — Radeaux de survie gonflables —
Partie 3: Matériaux



Reference number
ISO 9650-3:2009(E)

PDF disclaimer

This PDF file may contain embedded typefaces. In accordance with Adobe's licensing policy, this file may be printed or viewed but shall not be edited unless the typefaces which are embedded are licensed to and installed on the computer performing the editing. In downloading this file, parties accept therein the responsibility of not infringing Adobe's licensing policy. The ISO Central Secretariat accepts no liability in this area.

Adobe is a trademark of Adobe Systems Incorporated.

Details of the software products used to create this PDF file can be found in the General Info relative to the file; the PDF-creation parameters were optimized for printing. Every care has been taken to ensure that the file is suitable for use by ISO member bodies. In the unlikely event that a problem relating to it is found, please inform the Central Secretariat at the address given below.



COPYRIGHT PROTECTED DOCUMENT

© ISO 2009

All rights reserved. Unless otherwise specified, no part of this publication may be reproduced or utilized in any form or by any means, electronic or mechanical, including photocopying and microfilm, without permission in writing from either ISO at the address below or ISO's member body in the country of the requester.

ISO copyright office
Case postale 56 • CH-1211 Geneva 20
Tel. + 41 22 749 01 11
Fax + 41 22 749 09 47
E-mail copyright@iso.org
Web www.iso.org

Published in Switzerland

Foreword

ISO (the International Organization for Standardization) is a worldwide federation of national standards bodies (ISO member bodies). The work of preparing International Standards is normally carried out through ISO technical committees. Each member body interested in a subject for which a technical committee has been established has the right to be represented on that committee. International organizations, governmental and non-governmental, in liaison with ISO, also take part in the work. ISO collaborates closely with the International Electrotechnical Commission (IEC) on all matters of electrotechnical standardization.

International Standards are drafted in accordance with the rules given in the ISO/IEC Directives, Part 2.

The main task of technical committees is to prepare International Standards. Draft International Standards adopted by the technical committees are circulated to the member bodies for voting. Publication as an International Standard requires approval by at least 75 % of the member bodies casting a vote.

Attention is drawn to the possibility that some of the elements of this document may be the subject of patent rights. ISO shall not be held responsible for identifying any or all such patent rights.

ISO 9650-3 was prepared by Technical Committee ISO/TC 188, *Small craft*.

This second edition cancels and replaces the first edition (ISO 9650-3:2005), which has been technically revised.

ISO 9650 consists of the following parts, under the general title *Small craft — Inflatable liferafts*:

- *Part 1: Type I*
- *Part 2: Type II*
- *Part 3: Materials*

1

Small craft — Inflatable liferafts —

Part 3: Materials

1 Scope

This part of ISO 9650 specifies requirements and test methods for the materials used in the construction of the inflatable liferafts specified in ISO 9650-1 and ISO 9650-2.

2 Normative references

The following referenced documents are indispensable for the application of this document. For dated references, only the edition cited applies. For undated references, the latest edition of the referenced document (including any amendments) applies.

ISO 1419, *Rubber- or plastics-coated fabrics — Accelerated-ageing tests*

ISO 1421, *Rubber- or plastics-coated fabrics — Determination of tensile strength and elongation at break*

ISO 2231, *Rubber- or plastics-coated fabrics — Standard atmospheres for conditioning and testing*

ISO 2411, *Rubber- or plastics-coated fabrics — Determination of coating adhesion*

ISO 3011, *Rubber- or plastics-coated fabrics — Determination of resistance to ozone cracking under static conditions*

ISO 4674-1, *Rubber- or plastics-coated fabrics — Determination of tear resistance — Part 1: Constant rate of tear methods*

ISO 4675:1990, *Rubber- or plastics-coated fabrics — Low-temperature bend test*

ISO 5978, *Rubber- or plastics-coated fabrics — Determination of blocking resistance*

ISO 9227, *Corrosion tests in artificial atmospheres — Salt spray tests*

3 Fabrics

3.1 Materials

The materials used for the buoyancy chambers, floor, canopy support and canopy shall be single- or double-faced coated fabrics.

The base fabric shall be inherently rot-proof.

NOTE Cotton base fabric will not be considered as rot-proof.

3.2 Tests

When tested by the methods described in Clause 6, the materials shall comply with the requirements specified in Table 1.

Table 1 — Performance requirements

Property	Performance requirements		Subclause number
	Buoyancy chambers/floor	Canopy	
Tensile strength	Not less than 1500 N/50 mm warp 1300 N/50 mm weft	Not less than 650 N/50 mm warp 650 N/50 mm weft	6.2
Tear strength, constant rate of traverse method A	Not less than 80 N for both warp and weft	Not less than 30 N for both warp and weft	6.3
Coating adhesion, ply separation and surface receptiveness test	Not less than 15 N/10 mm	Not less than 5 N/10 mm only for glued and welded assemblies	6.4
Low-temperature bend test	1) buoyancy chamber material ^a Cracking when tested at – 50 °C is permissible only if an internal insulation and protection system is used. No cracking or other visible deterioration when tested at – 30 °C 2) floor material No cracking or other visible deterioration when tested at – 15 °C ± 1 °C	No cracking or other visible deterioration when tested at – 15 °C	6.5
Ozone resistance	No visible cracking	N/A	6.6
Porosity	No bubbles visible within 5 min of the start of the test ^a	N/A	6.7
Ageing test	No cracking, blistering or stickiness	N/A	6.8
Hydrolysis test	After 14 d at 70 °C, 95 % relative humidity, following ISO 1419, method C: 1) coating adhesion test: not less than 10 N/10 mm 2) folding test: no cracks	N/A	6.9
Resistance to blocking test	Rating between one and two	N/A	6.10
Oil resistance test	2 h at 20 °C No tackiness Test with ASTM no.1 oil	N/A	6.11
Buoyancy chamber seam strength test	1) On new samples: tensile strength not less than 90 % of the value specified ^b in warp and weft 2) After ageing in accordance with 6.8: tensile strength not less than 70 % of the value obtained on new samples in warp and weft	N/A	6.12

^a For liferafts using an internal bladder construction, these tests (low-temperature bend test and porosity test) are applicable only to the inner bladder material. The outer support material shall meet a – 15°C low-temperature bend test.

^b For liferafts using internal bladders, the specified value is 1 000 N/50 mm.

4 Adhesives

Adhesives used in the manufacture of liferafts shall be compatible with the materials used. Whenever a test method requires the use of an adhesive, the method of preparation of the adhesive and its method of application shall be the same as those used during manufacture of the liferaft.

5 Metallic parts

All exposed metallic parts shall be tested in accordance with ISO 9227 for two periods of 24 h with a 2 h drying period in between (i.e. a total test time of 50 h).

After this test there shall be no corrosion that might impair the function of the component.

6 Methods of test for coated materials

6.1 General conditions for tests

6.1.1 Standard environmental conditions

Unless otherwise specified, the standard environmental conditions for the tests shall be in conformance with ISO 2231. Atmosphere B shall be used. The temperature, humidity and atmospheric pressure at the time of test shall be recorded.

6.1.2 Test specimens

The required number of test specimens shall be taken from the effective width of a coated fabric, well away from the selvages and the ends, and in a direction parallel with the warp or parallel with the weft as required. This does not apply to the ozone test or the porosity test.

6.2 Tensile strength

This test shall be carried out to determine the breaking strength under a tensile load.

The test shall be performed in accordance with ISO 1421, method 1, using dry test strips.

6.3 Tear test (constant rate of traverse method)

This test shall be carried out in accordance with ISO 4674-1, method A, using dry test specimens.

6.4 Coating adhesion, ply separation and surface receptiveness test

Adhesion between coating and fabric shall be tested in accordance with the method specified in ISO 2411. All coated surfaces shall be tested.

The adhesion strength is expressed as the arithmetic mean of the strengths of the specimens.

6.5 Low-temperature bend test

This test shall be carried out in accordance with ISO 4675 on each coated surface of the material.

Test specimens for all materials shall be exposed at the test temperature for one hour before tests are carried out.

6.6 Ozone resistance test

This test shall be carried out in accordance with ISO 3011.

Three test specimens 25 mm wide and 100 mm long shall be tested under the following conditions:

- concentration of ozone (50 ± 5) parts per hundred million by volume;
- temperature (30 ± 2) °C;
- time test 24 h;
- mandrel diameter 10 times the material thickness.

Inspect the specimens under a magnification of × 5 on a mandrel of a diameter 10 times the thickness of the material. There shall be no visible cracking in accordance with ISO 4675:1990, Clauses 8 and 9.

6.7 Porosity test

6.7.1 Apparatus

The apparatus required is shown diagrammatically in Figure 1.

Dimensions in millimetres

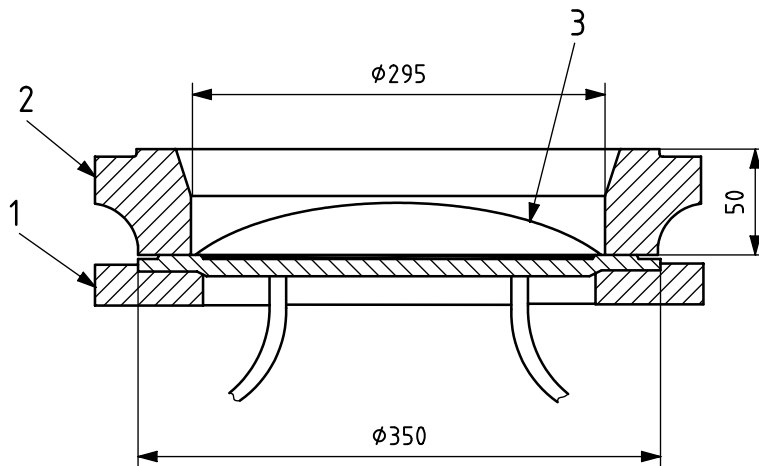

Key

- 1 base plate with air inlet and connection to gauge, having grooved margin for clamping
- 2 grooved mating clamping ring having sufficient depth to permit flooding of specimen with water
- 3 fabric specimen

The fabric shall be gripped tightly between the clamping ring and base by the use of G-clamps. Alternatively, the ring and base shall have eight equally spaced lugs cast on them, drilled to take bolts.

Figure 1 — Apparatus for air porosity test

6.7.2 Preparation of specimen

Cut from the test sample a disc 350 mm in diameter and seal at the periphery on both surfaces and the edge by dipping in molten wax to leave a wax-free central test area 290 mm in diameter. Air the specimen for 24 h before testing.

NOTE A mixture of seven parts petroleum jelly and two parts beeswax is suitable.

If the material used is not a fabric but a film, a high-porosity fabric or a frame may be added on top of the film to avoid an excessive extension of the film during the porosity test.

6.7.3 Procedure

Carry out the following procedure at a temperature of not less than 19 °C:

- a) Clamp the specimen, with the outer face uppermost, firmly in the apparatus.
- b) Apply and maintain beneath the fabric an air pressure of 27,5 kN/m².
- c) Not less than 10 min nor more than 15 min after the pressure has become steady, flood the fabric with water so that the crown of the bulge is immersed to a depth of about 13 mm.
- d) Allow to stand for 1 min and then brush the surface all over with a fairly soft brush to remove adherent air bubbles.
- e) Record zero time and count the number of bubbles breaking the surface of the water in 5 min.
- f) If the specimen contains a single-site leak, disregard the result, repeat the test on two further specimens from the same piece and report the occurrence.

6.8 Ageing test

This test shall be carried out in accordance with ISO 1419, method B, for 7 d at a temperature of (70 ± 1) °C. There shall be no visible cracking in accordance with ISO 4675:1990, Clauses 8 and 9.

6.9 Hydrolysis test

6.9.1 Method

14 d at 70 °C, 95 % relative humidity following ISO 1419, method C.

6.9.2 Coating test

See 6.4.

6.9.3 Folding test

Reference to MSC.81(70), clause 5.17.13.2.2.4.6.3:

Remove the other two specimens. After 15 min at room temperature, fold the specimens consecutively in two directions parallel to the edges at right angles to each other so as to reduce the exposed area of each specimen to one quarter of its original size. Unfold and refold along the same creases but with each fold reversed in direction. After each folding, press the fold by rubbing fingers and thumb along it: inspect the specimens for cracks, separation of plies, stickiness or brittleness.

There shall be no visible cracking in accordance with ISO 4675:1990, Clauses 8 and 9.

6.10 Resistance to blocking test

This test shall be carried out in accordance with ISO 5978 [5 kg mass for 3 h at $(70 \pm 2)^\circ\text{C}$].

6.11 Oil resistance test

Reference to MSC.81(70), Clause 5.17.13.2.2.8:

When tested by the method prescribed below, after exposing the outer surface to oil ASTM No. 1 for 2 h at $(20 \pm 2)^\circ\text{C}$, there should be no separation of coating from textile and no residual tackiness when two exposed faces are pressed together. The coating should not smear when rubbed with a single pass of the finger.

The test should be carried out not less than 16 h after vulcanization or curing.

The apparatus, preparation of specimens and test procedure should be in accordance with ISO/TR 6065:1991, A.2.5. Each coated face should be tested.

6.12 Chamber seam strength test

This test shall be carried out in accordance with ISO 1421 with ageing according to 6.8.

The seam to be tested is the longitudinal closing of the chamber.

Bibliography

- [1] ISO/TR 6065:1991, *Shipbuilding and marine structures — Inflatable liferafts — Materials*
- [2] IMO Res. A.689 (17), as amended through Res. MSC.81(70), *Revised recommendation on testing of life-saving appliances*, International Maritime Organization (IMO)

ICS 47.080

Price based on 7 pages