

INTERNATIONAL
STANDARD

ISO
9628

Second edition
2006-04-01

**Rolling bearings — Insert bearings and
eccentric locking collars — Boundary
dimensions and tolerances**

*Roulements — Roulements "insert" et bagues de blocage
excentriques — Dimensions d'encombrement et tolérances*



Reference number
ISO 9628:2006(E)

© ISO 2006

PDF disclaimer

This PDF file may contain embedded typefaces. In accordance with Adobe's licensing policy, this file may be printed or viewed but shall not be edited unless the typefaces which are embedded are licensed to and installed on the computer performing the editing. In downloading this file, parties accept therein the responsibility of not infringing Adobe's licensing policy. The ISO Central Secretariat accepts no liability in this area.

Adobe is a trademark of Adobe Systems Incorporated.

Details of the software products used to create this PDF file can be found in the General Info relative to the file; the PDF-creation parameters were optimized for printing. Every care has been taken to ensure that the file is suitable for use by ISO member bodies. In the unlikely event that a problem relating to it is found, please inform the Central Secretariat at the address given below.

© ISO 2006

All rights reserved. Unless otherwise specified, no part of this publication may be reproduced or utilized in any form or by any means, electronic or mechanical, including photocopying and microfilm, without permission in writing from either ISO at the address below or ISO's member body in the country of the requester.

ISO copyright office
Case postale 56 • CH-1211 Geneva 20
Tel. + 41 22 749 01 11
Fax + 41 22 749 09 47
E-mail copyright@iso.org
Web www.iso.org

Published in Switzerland

Contents

Page

Foreword	iv
1 Scope	1
2 Normative references	1
3 Terms and definitions	1
4 Symbols	1
5 Characteristics	5
5.1 General	5
5.2 Bore diameter	6
5.3 Outside diameter of bearing	6
5.4 Width of inner ring and locking device	6
5.5 Width of outer ring	6
5.6 Relubrication	6
6 Boundary dimensions	6
7 Tolerances	17
8 Radial internal clearances	17

Foreword

ISO (the International Organization for Standardization) is a worldwide federation of national standards bodies (ISO member bodies). The work of preparing International Standards is normally carried out through ISO technical committees. Each member body interested in a subject for which a technical committee has been established has the right to be represented on that committee. International organizations, governmental and non-governmental, in liaison with ISO, also take part in the work. ISO collaborates closely with the International Electrotechnical Commission (IEC) on all matters of electrotechnical standardization.

International Standards are drafted in accordance with the rules given in the ISO/IEC Directives, Part 2.

The main task of technical committees is to prepare International Standards. Draft International Standards adopted by the technical committees are circulated to the member bodies for voting. Publication as an International Standard requires approval by at least 75 % of the member bodies casting a vote.

Attention is drawn to the possibility that some of the elements of this document may be the subject of patent rights. ISO shall not be held responsible for identifying any or all such patent rights.

ISO 9628 was prepared by Technical Committee ISO/TC 4, *Rolling bearings*, Subcommittee SC 6, *Insert bearings and accessories*.

This second edition cancels and replaces the first edition (ISO 9628:1992), which has been technically revised.

Rolling bearings — Insert bearings and eccentric locking collars — Boundary dimensions and tolerances

1 Scope

This International Standard specifies the characteristics, boundary dimensions and tolerances of insert bearings and eccentric locking collars and the radial internal clearances of insert bearings.

2 Normative references

The following referenced documents are indispensable for the application of this document. For dated references, only the edition cited applies. For undated references, the latest edition of the referenced document (including any amendments) applies.

ISO 15:1998, *Rolling bearings — Radial bearings — Boundary dimensions, general plan*

ISO 1132-1, *Rolling bearings — Tolerances — Part 1: Terms and definitions*

ISO 5593, *Rolling bearings — Vocabulary*

ISO 15241, *Rolling bearings — Symbols for quantities*

3 Terms and definitions

For the purposes of this document, the terms and definitions given in ISO 1132-1 and ISO 5593, and the following, apply.

3.1

insert bearing

radial rolling bearing with a spherical outside surface and an extended inner ring with a locking device

NOTE The locking device, used for fixing the inner ring to the shaft, may be an eccentric locking collar or set screws either in a concentric locking collar around the inner ring or directly in the inner ring.

4 Symbols

For the purposes of this document, the symbols given in ISO 15241 and the following apply.

The symbols (except those for tolerances) shown in Figures 1 to 6 and the values given in Tables 1 to 8 denote nominal dimensions unless specified otherwise.

NOTE Figures 1 to 6 are drawn schematically and sealing devices and cages are not shown in Figures 1 to 4.

A	width of eccentric surface of inner ring
A_1	width of eccentric surface of eccentric locking collar
B	width of inner ring

B_1	overall width of inner ring including eccentric locking collar
B_2	width of eccentric locking collar
C	width of outer ring
C_1	distance from centre of outer ring to centre of lubrication zone
C_2	width of lubrication zone
D	outside diameter of bearing
d	bore diameter of bearing and of eccentric locking collar
d_1	outside diameter of eccentric locking collar
d_2	small bore diameter of eccentric surface (at theoretical sharp corner) of eccentric locking collar
d_3	large outside diameter of eccentric surface (at theoretical sharp corner) of inner ring
H	eccentricity of inner ring eccentric extension and of eccentric locking collar
r_1	chamfer dimension of eccentric surface of inner ring
$r_{1s \text{ min}}$	smallest single chamfer dimension of eccentric surface of inner ring
r_2	fillet radius of eccentric surface of inner ring
$r_{2s \text{ max}}$	largest single fillet radius of eccentric surface of inner ring
r_3	fillet radius of eccentric surface of eccentric locking collar
$r_{3s \text{ max}}$	largest single fillet radius of eccentric surface of eccentric locking collar
r_4	chamfer dimension of eccentric surface of eccentric locking collar
$r_{4s \text{ min}}$	smallest single chamfer dimension of eccentric surface of eccentric locking collar
S	distance from centre of raceway to face of inner ring on side opposite locking device
S_1	distance from centre of raceway to face of inner ring or eccentric locking collar limiting overall bearing width on locking device side
V_{dsp}	variation of bore diameter of bearing in a single plane
Δ_{A1s}	deviation of a single width of eccentric surface of eccentric locking collar
Δ_{B2s}	deviation of a single width of eccentric locking collar
Δ_{dmp}	deviation of mean bore diameter of bearing in a single plane
Δ_{ds}	deviation of a single bore diameter of eccentric locking collar
Δ_{d2s}	deviation of a single small bore diameter of eccentric surface of eccentric locking collar
Δ_{Hs}	deviation of eccentricity of inner ring eccentric extension and of eccentric locking collar in a single plane

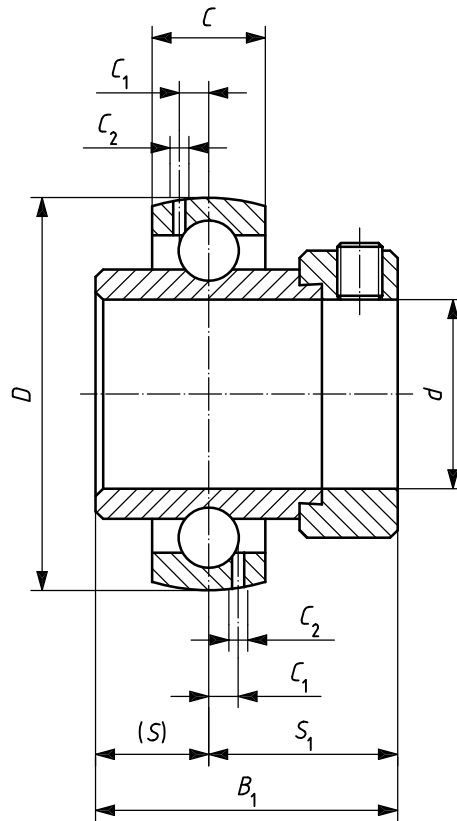

Figure 1 — Bearing with eccentric locking collar — Wide overall width

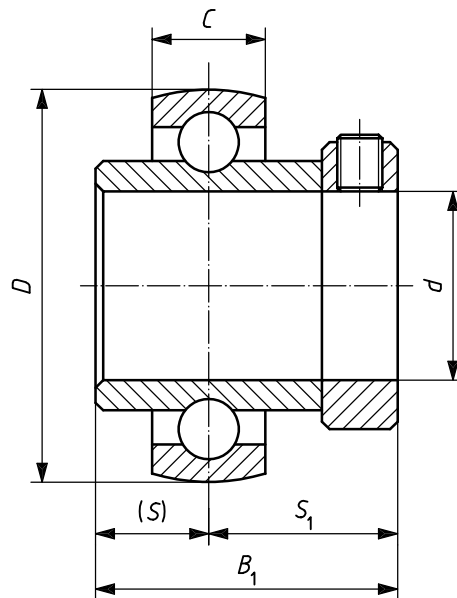

Figure 2 — Bearing with concentric locking collar around the inner ring — Intermediate overall width

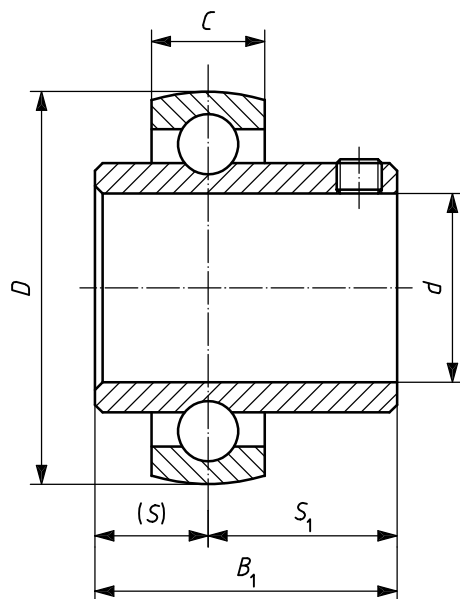

Figure 3 — Bearing with set screws in the inner ring — Intermediate overall width

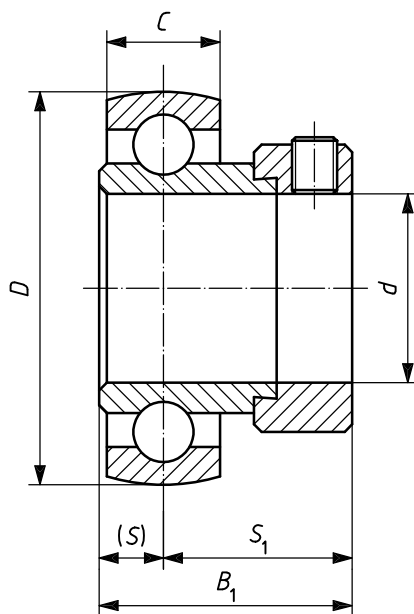

Figure 4 — Bearing with eccentric locking collar — Narrow overall width

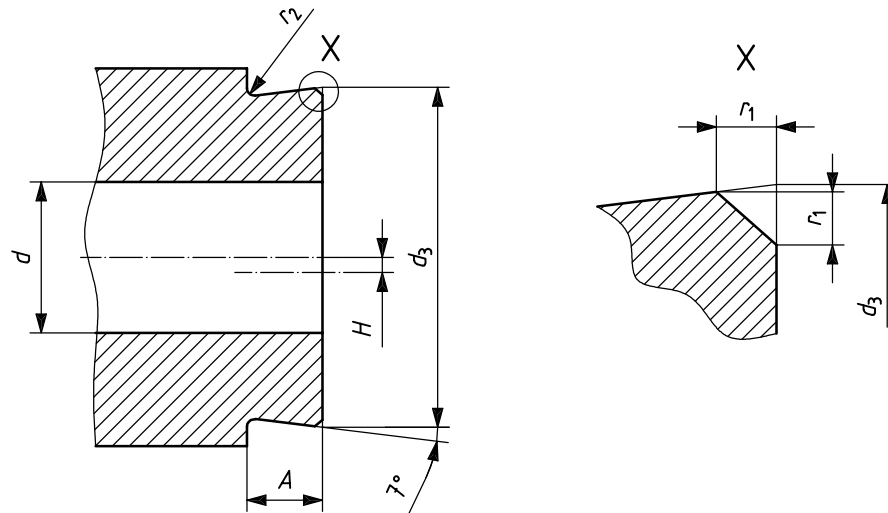
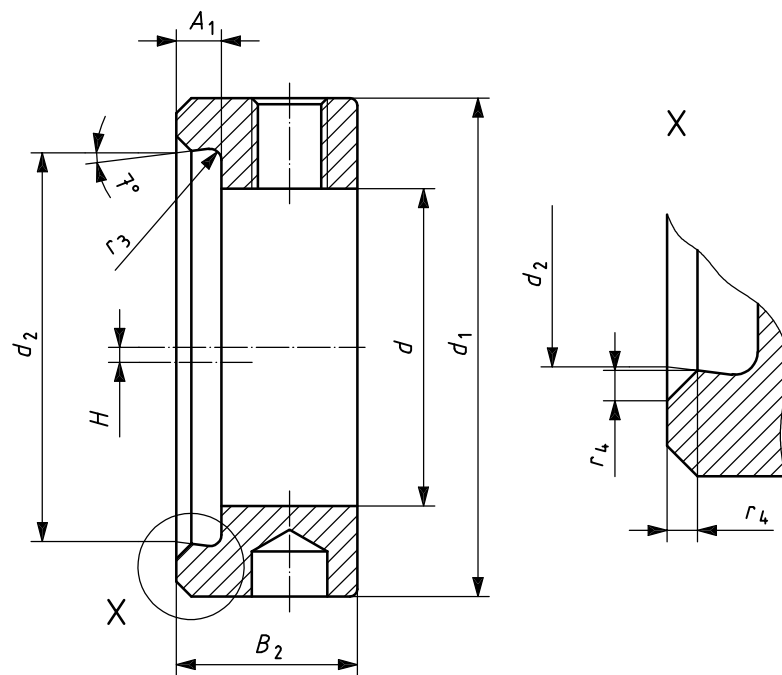

Figure 5 — Eccentric extension of inner ring



NOTE The relative angular position of the plain and tapped holes to each other and to the eccentricity is optional.

Figure 6 — Eccentric locking collar

5 Characteristics

5.1 General

The bearings on one shaft are, as a rule, mounted in two or more separate housings, which are not always perfectly aligned. The outer ring has a spherical outside surface so that the bearing can be mounted in a housing with a matching spherical seating to accommodate permanent angular misalignment.

The bore surface of the bearing inner ring and the eccentric locking collar may be plated or treated with a surface treatment to reduce corrosion during operation.

5.2 Bore diameter

For bearings with eccentric locking collar, the size of the eccentric feature on the inner ring and the locking collar is generally common for one metric and several inch inner ring bore sizes. The non-preferred inch bore sizes, which are given in parentheses in Tables 1 to 3, should be avoided whenever possible.

Contrary to general rolling bearing practice, the inner ring bore diameter tolerance is on the plus side of the nominal bore diameter, in order that the bearing and collar can be slipped over standard size shafting.

5.3 Outside diameter of bearing

The outside diameter of the bearing corresponds (with respect to the metric bore diameter) to the diameter series 2 of ISO 15:1998.

5.4 Width of inner ring and locking device

The inner ring width (with respect to the metric bore diameter) does not conform to the requirements of dimension series 02 of ISO 15:1998. It is determined by the requirements of space for sealing and locking devices and by the axial extension of the shaft support considered suitable for various applications.

Where the locking device extends axially beyond the inner ring, the width over the locking device, called the overall width, and the location with respect to the outer ring centreline of the side face limiting the overall width, are important dimensions and are therefore specified in this International Standard.

Three series of overall widths are given, designated wide, intermediate and narrow. Each of Figures 1 to 4 shows one example only of locking device design.

5.5 Width of outer ring

For bearings with a spherical outside surface the width of the outer ring is not important, provided the range of width is known so that assembly slots in the housing can be properly dimensioned. This International Standard therefore gives outer ring widths which range from a minimum that conforms to dimension series 02 in ISO 15:1998, to a maximum that provides sufficient space for various seals and relubrication holes.

5.6 Relubrication

Depending on the application, these bearings are supplied with or without means for relubrication, for example, one or more small radial holes drilled through the outer ring. The exact design and location of such means are not specified in this International Standard. Given only is the width and location of a zone in which any relubrication means, provided on one or both sides of the outer ring, should intersect in such a way that lubricant will satisfactorily feed into the bearing from the housing bore groove covering the zone.

6 Boundary dimensions

Boundary dimensions for insert bearings and eccentric locking collars are given in Tables 1 to 5.

Table 1 — Insert bearings — Wide overall width — Axially extending eccentric locking collar
(see Figure 1)

d		D	B_1 max.	(S)	S_1 max.	C^a		C_1^b	C_2^b
mm	in					mm	mm		
12	—	40	37,3	13,9	23,4	12	15	3,4	2
12,7	1/2								
(14,288)	(9/16)								
15	—	47	43,7	17,1	26,6	14	17	3,7	2
15,875	5/8								
17	—								
(17,462)	(11/16)	52	44,4	17,5	26,9	15	17	3,9	2,5
19,05	3/4								
20	—								
(20,638)	(13/16)	62	48,4	18,3	30,1	16	19	5	2,5
22,225	7/8								
(23,812)	(15/16)								
25	—	72	51,1	18,8	32,3	17	20	5,7	3
25,4	1								
(26,988)	(1-1/16)								
28,575	1-1/8	80	56,3	21,4	34,9	18	21	6,2	3
30	—								
30,162	1-3/16								
(31,75)	(1-1/4)	85	56,3	21,4	34,9	19	22	6,4	3
31,75	1-1/4								
(33,338)	(1-5/16)								
34,925	1-3/8	90	62,7	24,6	38,1	20	24	6,5	3,5
35	—								
36,512	1-7/16								
38,1	1-1/2	90	62,7	24,6	38,1	20	24	6,5	3,5
(39,688)	(1-9/16)								
40	—								
(41,275)	(1-5/8)	90	62,7	24,6	38,1	20	24	6,5	3,5
42,862	1-11/16								
44,45	1-3/4								
45	—	90	62,7	24,6	38,1	20	24	6,5	3,5
(46,038)	(1-13/16)								
(47,625)	(1-7/8)								
49,212	1-15/16	90	62,7	24,6	38,1	20	24	6,5	3,5
50	—								
(50,8)	(2)								

Table 1 (continued)

<i>d</i>		<i>D</i> mm	<i>B</i> ₁ max.	<i>(S)</i> mm	<i>S</i> ₁ max.	<i>C</i> ^a		<i>C</i> ₁ ^b mm	<i>C</i> ₂ ^b mm
mm	in		mm		mm	mm	min.		
50,8 (52,388) (53,975)	2 (2-1/16) (2-1/8)	100	71,4	27,8	43,6	21	25	7	3,5
55 55,562	— 2-3/16								
57,15 (58,738)	2-1/4 (2-5/16)								
60 (60,325)	— (2-3/8)	110	77,8	31	46,8	22	27	7,6	4
61,912	2-7/16								
(63,5)	(2-1/2)								
65	—	120	85,7	34,1	51,6	23	32	8,9	5
68,262	2-11/16								
70	—								
(71,438)	(2-13/16)	130	92,1	37,3	54,8	25	39	8,9	5
74,612	2-15/16								
75	—								
(79,375)	(3-1/8)	140	100	40,5	59,5	26	43	8,8	6
80	—								
80,962	3-3/16								
85	—	150	106,4	43,7	62,7	28	50	10	6
87,312	3-7/16								
90	—								
93,662	3-11/16	170	114,3	46,8	67,5	32	50	10	6
95	—								
100	—								
100,012	3-15/16	180	125,4	50	75,4	34	51	11,2	6

NOTE Non-preferred inch bore sizes are shown in parentheses.

^a The minimum and maximum widths are not tolerances; they indicate a range within which the nominal value shall fall.

^b The relubrication means in the outer ring, if used, shall be located on one or both sides of the outer ring in the zones defined by the dimensions *C*₁ and *C*₂ in such a way that lubricant will satisfactorily feed into the bearing from a housing bore groove covering the zone.

Table 2 — Insert bearings — Intermediate overall width — Locking device not axially extending
(see Figures 2 and 3)

d		D	B_1 max.	(S)	S_1 max.	C^a		C_1^b	C_2^b
mm	in					mm	mm		
12	—	40	27,4	11,5	15,9	12	15	3,4	2
12,7	1/2								
(14,288)	(9/16)								
15	—	47	31	12,7	18,3	14	17	3,7	2
15,875	5/8								
17	—								
(17,462)	(11/16)	52	34,1	14,3	19,8	15	17	3,9	2,5
19,05	3/4								
20	—								
(20,638)	(13/16)	62	38,1	15,9	22,2	16	19	5	2,5
22,225	7/8								
(23,812)	15/16								
25	—	72	42,9	17,5	25,4	17	20	5,7	3
25,4	1								
(26,988)	(1-1/16)								
28,575	1-1/6	80	49,2	19	30,2	18	21	6,2	3
30	—								
30,162	1-3/16								
(31,75)	(1-1/4)	85	49,2	19	30,2	19	22	6,4	3
31,75	1-1/4								
(33,338)	(1-5/16)								
34,925	(1-3/8)	90	51,6	19	32,6	20	24	6,5	3,5
35	—								
36,512	1-7/16								
38,1	1-1/2	90	51,6	19	32,6	20	24	6,5	3,5
(39,688)	(1-9/16)								
40	—								
(41,275)	(1-5/8)	90	51,6	19	32,6	20	24	6,5	3,5
42,862	1-11/16								
44,45	1-3/4								
45	—	90	51,6	19	32,6	20	24	6,5	3,5
(46,038)	(1-13/16)								
(47,625)	(1-7/8)								
49,212	1-15/16	90	51,6	19	32,6	20	24	6,5	3,5
50	—								
(50,8)	(2)								

Table 2 (continued)

<i>d</i>		<i>D</i>	<i>B</i> ₁ max.	<i>(S)</i>	<i>S</i> ₁ max.	<i>C</i> ^a		<i>C</i> ₁ ^b	<i>C</i> ₂ ^b
mm	in					mm	mm		
50,8 (52,388) (53,975)	2 (2-1/16) (2-1/8)	100	55,6	22,2	33,4	21	25	7	3,5
55 55,562	— 2-3/16								
57,15 (58,738)	2-1/4 (2-5/16)								
60 (60,325)	— (2-3/8)	110	65,1	25,4	39,7	22	27	7,6	4
61,912	2-7/16								
(63,5)	(2-1/2)								
65 (66,675)	— (2-5/8)	120	68,3	25,4	42,9	23	32	8,9	5
68,262 (69,85)	2-11/16 (2-3/4)								
70	—								
(71,438) (73,025)	(2-13/16) (2-7/8)	130	77,8	33,3	44,5	25	39	8,9	5
74,612	2-15/16								
75	—								
76,2	3								
(79,375)	(3-1/8)	140	82,6	33,3	49,3	26	43	8,8	6
80	—								
80,962	3-3/16								
(82,55)	(3-1/4)	150	85,7	34,1	51,6	28	50	10	6
85	—								
(85,725)	(3-3/8)								
87,312 (88,9)	3-7/16 (3-1/2)								
88,9	3-1/2	160	96	39,7	56,3	30	50	10	6
90	—								
100 100,012 (101,6)	— 3-15/16 (4)	180	108	42	66	34	51	11,2	6

NOTE Non-preferred inch bore sizes are shown in parentheses.

^a The minimum and maximum widths are not tolerances; they indicate a range within which the nominal value shall fall.

^b The relubrication means in the outer ring, if used, shall be located on one or both sides of the outer ring in the zones defined by the dimensions *C*₁ and *C*₂ in such a way that lubricant will satisfactorily feed into the bearing from a housing bore groove covering the zone.

Table 3 — Insert bearings — Narrow overall width — Axially extending eccentric locking collar
(see Figure 4)

d		D	B_1 max.	(S)	S_1 max.	C^a		C_1^b	C_2^b
mm	in					mm	mm		
12	—	40	28,6	6,5	22,1	12	13	3,4	2
12,7	1/2								
(14,288)	(9/16)								
15	—	47	31	7,5	23,5	14	15	3,7	2
15,875	5/8								
17	—								
(17,462)	(11/16)	52	31	7,5	23,5	15	15	3,9	2,5
19,05	3/4								
20	—								
(20,638)	(13/16)	62	35,7	9	26,7	16	18	5	2,5
22,225	7/8								
(23,812)	15/16								
25	—	72	38,9	9,5	29,4	17	19	5,7	3
25,4	1								
(26,988)	(1-1/16)								
28,575	1-1/8	80	43,7	11	32,7	18	22	6,2	3
30	—								
30,162	1-3/16								
(31,75)	(1-1/4)	85	43,7	11	32,7	19	22	6,4	3
31,75	1-1/4								
(33,338)	(1-5/16)								
34,925	1-3/8	90	43,7	11	32,7	20	22	6,5	3,5
35	—								
36,512	1-7/16								
38,1	1-1/2	90	43,7	11	32,7	20	22	6,5	3,5
(39,688)	(1-9/16)								
40	—								
(41,275)	(1-5/8)	90	43,7	11	32,7	20	22	6,5	3,5
42,862	1-11/16								
44,45	1-3/4								
45	—	90	43,7	11	32,7	20	22	6,5	3,5
(46,038)	(1-13/16)								
(47,625)	(1-7/8)								
49,212	1-15/16	90	43,7	11	32,7	20	22	6,5	3,5
50	—								
(50,8)	(2)								

Table 3 (continued)

d		D	B_1	(S)	S_1	C^a		C_1^b	C_2^b
mm	in		max.		max.	min.	max.		
		mm	mm	mm	mm	mm		mm	mm
50,8	2	100	48,4	12	36,4	21	25	7	3,5
(52,388)	(2-1/16)								
(53,975)	(2-1/8)								
55	—	110	53,1	13,5	39,6	22	27	7,6	4
55,562	2-3/16								
57,15	2-1/4								
(58,738)	(2-5/16)	110	53,1	13,5	39,6	22	27	7,6	4
60	—								
(60,325)	(2-3/8)								
61,912	2-7/16								

NOTE Non-preferred inch bore sizes are shown in parentheses.

^a The minimum and maximum widths are not tolerances; they indicate a range within which the nominal value shall fall.

^b The relubrication means in the outer ring, if used, shall be located on one or both sides of the outer ring in the zones defined by the dimensions C_1 and C_2 in such a way that lubricant will satisfactorily feed into the bearing from a housing bore groove covering the zone.

Table 4 — Insert bearings — Inner ring eccentric extension — Wide and narrow overall width
(see Figures 1, 4 and 5)

<i>d</i>		<i>d</i> ₃ max.	<i>H</i>	<i>A</i> min.	<i>r</i> _{1s} min	<i>r</i> _{2s} max
mm	in	mm	mm	mm	mm	mm
12	—	21,6	0,8	4,2	0,5	0,8
12,7	1/2					
14,288	9/16					
15	—					
15,875	5/8					
17	—					
17,462	11/16					
19,05	3/4	26,6	0,8	4,2	0,5	0,8
20	—					
20,638	13/16	31,6	0,8	4,2	0,5	0,8
22,225	7/8					
23,812	15/16					
25	—					
25,4	1					
26,988	1-1/16	37,9	0,8	4,2	0,5	0,8
28,575	1-1/8					
30	—					
30,162	1-3/16					
31,75	1-1/4					
31,75	1-1/4	44,7	0,8	4,2	0,5	0,8
33,338	1-5/16					
34,925	1-3/8					
35	—					
36,512	1-7/16					
38,1	1-1/2	49,4	1,6	5	0,5	1,2
39,688	1-9/16					
40	—					
41,275	1-5/8	54,4	1,6	5	0,5	1,2
42,862	1-11/16					
44,45	1-3/4					
45	—					
46,038	1-13/16	60	1,6	5	0,5	1,2
47,625	1-7/8					
49,212	1-15/16					
50	—					
50,8	2					

Table 4 (continued)

<i>d</i>		<i>d</i> ₃ max.	<i>H</i>	<i>A</i> min.	<i>r</i> _{1s} min	<i>r</i> _{2s} max
mm	in	mm	mm	mm	mm	mm
50,8	2	66,9	1,6	5	0,5	1,2
52,388	2-1/16					
53,975	2-1/8					
55	—					
55,562	2-3/16					
57,15	2-1/4	73,5	1,6	6,6	0,5	1,6
58,738	2-5/16					
60	—					
60,325	2-3/8					
61,912	2-7/16					
63,5	2-1/2	78,6	1,6	6,6	0,5	1,6
65	—					
68,262	2-11/16	82	1,6	6,6	0,5	1,6
70	—					
71,438	2-13/16	87	1,6	6,6	0,5	1,6
74,612	2-15/16					
75	—					
79,375	3-1/8	92,7	1,6	6,6	0,5	1,6
80	—					
80,962	3-3/16					
85	—	102	1,6	6,6	0,5	1,6
87,312	3-7/16					
90	—	106,1	1,6	6,6	0,5	1,6
93,662	3-11/16	115,5	1,6	6,6	0,5	1,6
95	—					
100	—	118,9	1,6	6,6	0,5	1,6
100,012	3-15/16					

NOTE For preferred bearing sizes, refer to Tables 1 and 3.

Table 5 — Eccentric locking collars for insert bearings — Wide and narrow overall width (see Figure 6)

<i>d</i>		<i>d</i> ₁ max.	<i>d</i> ₂	<i>B</i> ₂	<i>H</i>	<i>A</i> ₁	<i>r</i> _{3s} max	<i>r</i> _{4s} min
mm	in	mm	mm	mm	mm	mm	mm	mm
12	—							
12,7	1/2							
14,288	9/16							
15	—	28,6	21,6	13,5	0,8	4	0,4	0,8
15,875	5/8							
17	—							
17,462	11/16							
19,05	3/4							
20	—	33,3	26,6	13,5	0,8	4	0,4	0,8
20,638	13/16							
22,225	7/8							
23,812	15/16	38,1	31,6	13,5	0,8	4	0,4	0,8
25	—							
25,4	1							
26,988	1-1/16							
28,575	1-1/8							
30	—	44,5	37,9	15,9	0,8	4	0,4	0,8
30,162	1-3/16							
31,75	1-1/4							
31,75	1-1/4							
33,338	1-5/16							
34,925	1-3/8	55,6	44,7	17,5	0,8	4	0,4	0,8
35	—							
36,512	1-7/16							
38,1	1-1/2							
39,688	1-9/16	60,3	49,4	18,3	1,6	4,8	0,4	1,2
40	—							
41,275	1-5/8							
42,862	1-11/16							
44,45	1-3/4	63,5	54,4	18,3	1,6	4,8	0,4	1,2
45	—							
46,038	1-13/16							
47,625	1-7/8							
49,212	1-15/16	69,9	60	18,3	1,6	4,8	0,4	1,2
50	—							
50,8	2							

Table 5 (continued)

<i>d</i>		<i>d</i> ₁ max.	<i>d</i> ₂	<i>B</i> ₂	<i>H</i>	<i>A</i> ₁	<i>r</i> _{3s} max	<i>r</i> _{4s} min
mm	in	mm	mm	mm	mm	mm	mm	mm
50,8	2							
52,388	2-1/16							
53,975	2-1/8	76,2	66,9	20,7	1,6	4,8	0,4	1,2
55	—							
55,562	2-3/16							
57,15	2-1/4							
58,738	2-5/16							
60	—	84,2	73,5	22,3	1,6	6,4	0,4	1,6
60,325	2-3/8							
61,912	2-7/16							
63,5	2-1/2							
65	—	97	78,6	23,9	1,6	6,4	0,4	1,6
68,262	2-11/16							
70	—	97	82	23,9	1,6	6,4	0,4	1,6
71,438	2-13/16							
74,612	2-15/16	102	87	23,9	1,6	6,4	0,4	1,6
75	—							
79,375	3-1/8							
80	—	111,1	92,7	25,4	1,6	6,4	0,4	1,6
80,962	3-3/16							
85	—	113	102	25,4	1,6	6,4	0,4	1,6
87,312	3-7/16							
90	—	119	106,1	25,4	1,6	6,4	0,4	1,6
93,662	3-11/16							
95	—	127	115,5	27	1,6	6,4	0,4	1,6
100	—	139,7	118,9	31,8	1,6	6,4	0,4	1,6
100,012	3-15/16							

NOTE For preferred bearing sizes, refer to Tables 1 and 3.

7 Tolerances

Tolerances for bearings and eccentric locking collars are given in Tables 6 and 7, respectively.

Table 6 — Tolerances for bearings

d		Δ_{dmp}		V_{dsp}	Δ_{Hs}	
$>$	\leq	high	low	max.	high	low
mm		μm		μm	μm	
10	18	+ 15	0	10	+ 100	- 100
18	31,75	+ 18	0	12	+ 100	- 100
31,75	50,8	+ 21	0	14	+ 100	- 100
50,8	80,962	+ 24	0	16	+ 100	- 100
80,962	120	+ 28	0	19	+ 100	- 100

NOTE Tolerance values are applicable to finished bore diameters, whether or not the bore is plated or treated.

Table 7 — Tolerances for eccentric locking collars

d		Δ_{ds}		Δ_{d2s}		Δ_{Hs}		Δ_{B2s}		Δ_{A1s}	
$>$	\leq	high	low	high	low	high	low	high	low	high	low
mm		μm		μm		μm		μm		μm	
10	36,512	+ 250	+ 25	+ 300	0	+ 100	- 100	+ 270	- 270	0	- 180
36,512	55,562	+ 300	+ 25	+ 400	0	+ 100	- 100	+ 330	- 330	0	- 180
55,562	80,962	+ 300	+ 25	+ 400	0	+ 100	- 100	+ 330	- 330	0	- 220
80,962	120	+ 350	+ 35	+ 500	0	+ 100	- 100	+ 330	- 330	0	- 220

NOTE Tolerance values are applicable to finished bore diameters, whether or not the bore is plated or treated.

8 Radial internal clearances

Radial internal clearance of complete bearings is the arithmetical mean of the radial distances through which one of the rings can be displaced relative to the other, from one extreme position to the diametrically opposite extreme position, in different angular directions and without being subjected to any external load.

Values for radial internal clearance of complete bearings are given in Table 8.

Table 8 — Radial internal clearance

<i>d</i>		<i>D</i>	Group N		Group 3	
			min.	max.	min.	max.
mm	in	mm	µm		µm	
12	—	40	10	25	18	33
12,7	1/2					
14,288	9/16					
15	—					
15,875	5/8					
17	—					
17,462	11/16	47	12	28	20	36
19,05	3/4					
20	—					
20,638	13/16					
22,225	7/8					
23,812	15/16					
25	—	52	12	28	23	41
25,4	1					
26,988	1-1/16					
28,575	1-1/8					
30	—					
30,162	1-3/16					
31,75	1-1/4	62	12	28	23	41
26,988	1-1/16					
28,575	1-1/8					
30	—					
30,162	1-3/16					
31,75	1-1/4					
31,75	1-1/4	72	13	33	28	46
33,338	1-5/16					
34,925	1-3/8					
35	—					
36,512	1-7/16					
38,1	1-1/2					
39,688	1-9/16					
40	—					
41,275	1-5/8					
42,862	1-11/16					
44,45	1-3/4					
45	—	85	14	36	30	51
46,038	1-13/16					
47,625	1-7/8					
49,212	1-15/16					
50	—					
50,8	2					
46,038	1-13/16					
47,625	1-7/8					
49,212	1-15/16					
50	—					
50,8	2					

Table 8 (continued)

<i>d</i>		<i>D</i>	Group N		Group 3	
			min.	max.	min.	max.
mm	in	mm	μm		μm	
50,8	2	100	18	43	38	61
52,388	2-1/16					
53,975	2-1/8					
55	—					
55,562	2-3/16					
57,15	2-1/4	110	18	43	38	61
58,738	2-5/16					
60	—					
60,325	2-3/8					
61,912	2-7/16					
63,5	2-1/2	120	18	43	38	61
65	—					
66,675	2-5/8					
68,262	2-11/16	125	18	43	38	61
69,85	2-3/4					
70	—					
71,438	2-13/16	130	20	51	46	71
73,025	2-7/8					
74,612	2-18/16					
75	—					
76,2	3					
79,375	3-1/8	140	20	51	46	71
80	—					
80,962	3-3/16					
82,55	3-1/4	150	20	51	46	71
85	—					
85,725	3-3/8					
87,312	3-7/16					
88,9	3-1/2					
88,9	3-1/2	160	24	58	53	84
90	—					
93,662	3-11/16					
95	—	170	24	58	53	84
100	—					
100,012	3-15/16					
101,6	4	180	24	58	53	84

www.iso.org

ICS 21.100.20

Price based on 19 pages