

---

---

**Aerospace — Nuts, hexagonal, slotted (castellated), reduced height, normal across flats, with MJ threads, classifications: 450 MPa (at ambient temperature)/120 °C, 450 MPa (at ambient temperature)/235 °C, 600 MPa (at ambient temperature)/425 °C, 900 MPa (at ambient temperature)/235 °C, 900 MPa (at ambient temperature)/315 °C, 900 MPa (at ambient temperature)/650 °C, 1 100 MPa (at ambient temperature)/235 °C, 1 100 MPa (at ambient temperature)/730 °C and 1 250 MPa (at ambient temperature)/600 °C — Dimensions**

*Aéronautique et espace — Écrous hexagonaux à créneaux, hauteur réduite, surplats normaux, à filetage MJ, classifications: 450 MPa (à température ambiante)/120 °C, 450 MPa (à température ambiante)/235 °C, 600 MPa (à température ambiante)/425 °C, 900 MPa (à température ambiante)/235 °C, 900 MPa (à température ambiante)/315 °C, 900 MPa (à température ambiante)/650 °C, 1 100 MPa (à température ambiante)/235 °C, 1 100 MPa (à température ambiante)/730 °C et 1 250 MPa (à température ambiante)/600 °C — Dimensions*



**COPYRIGHT PROTECTED DOCUMENT**

© ISO 2016, Published in Switzerland

All rights reserved. Unless otherwise specified, no part of this publication may be reproduced or utilized otherwise in any form or by any means, electronic or mechanical, including photocopying, or posting on the internet or an intranet, without prior written permission. Permission can be requested from either ISO at the address below or ISO's member body in the country of the requester.

ISO copyright office  
Ch. de Blandonnet 8 • CP 401  
CH-1214 Vernier, Geneva, Switzerland  
Tel. +41 22 749 01 11  
Fax +41 22 749 09 47  
copyright@iso.org  
www.iso.org

# Contents

Page

<b>Foreword</b> .....	<b>iv</b>
<b>Introduction</b> .....	<b>v</b>
<b>1 Scope</b> .....	<b>1</b>
<b>2 Normative references</b> .....	<b>1</b>
<b>3 Configuration and dimensions</b> .....	<b>1</b>

## Foreword

ISO (the International Organization for Standardization) is a worldwide federation of national standards bodies (ISO member bodies). The work of preparing International Standards is normally carried out through ISO technical committees. Each member body interested in a subject for which a technical committee has been established has the right to be represented on that committee. International organizations, governmental and non-governmental, in liaison with ISO, also take part in the work. ISO collaborates closely with the International Electrotechnical Commission (IEC) on all matters of electrotechnical standardization.

The procedures used to develop this document and those intended for its further maintenance are described in the ISO/IEC Directives, Part 1. In particular the different approval criteria needed for the different types of ISO documents should be noted. This document was drafted in accordance with the editorial rules of the ISO/IEC Directives, Part 2 (see [www.iso.org/directives](http://www.iso.org/directives)).

Attention is drawn to the possibility that some of the elements of this document may be the subject of patent rights. ISO shall not be held responsible for identifying any or all such patent rights. Details of any patent rights identified during the development of the document will be in the Introduction and/or on the ISO list of patent declarations received (see [www.iso.org/patents](http://www.iso.org/patents)).

Any trade name used in this document is information given for the convenience of users and does not constitute an endorsement.

For an explanation on the meaning of ISO specific terms and expressions related to conformity assessment, as well as information about ISO's adherence to the WTO principles in the Technical Barriers to Trade (TBT) see the following URL: [Foreword - Supplementary information](#).

The committee responsible for this document is ISO/TC 20, *Aircraft and space vehicles*, Subcommittee SC 4, *Aerospace fastener systems*.

This second edition cancels and replaces the first edition (ISO 9618:1996), of which it constitutes a minor revision.

## Introduction

The dimensions specified in this International Standard have been determined to satisfy the requirements of the procurement specification which will be the subject of a future International Standard.



**Aerospace — Nuts, hexagonal, slotted (castellated), reduced height, normal across flats, with MJ threads, classifications: 450 MPa (at ambient temperature)/120 °C, 450 MPa (at ambient temperature)/235 °C, 600 MPa (at ambient temperature)/425 °C, 900 MPa (at ambient temperature)/235 °C, 900 MPa (at ambient temperature)/315 °C, 900 MPa (at ambient temperature)/650 °C, 1 100 MPa (at ambient temperature)/235 °C, 1 100 MPa (at ambient temperature)/730 °C and 1 250 MPa (at ambient temperature)/600 °C — Dimensions**

## 1 Scope

This International Standard specifies the dimensions of hexagon slotted (castellated) nuts, reduced height, normal across flats, with MJ threads, of classifications: 450 MPa/120 °C, 450 MPa/235 °C, 600 MPa/425 °C, 900 MPa/235 °C, 900 MPa/315 °C, 900 MPa/650 °C, 1 100 MPa/235 °C, 1 100 MPa/730 °C, and 1 250 MPa/600 °C.

NOTE 1 450 MPa, 600 MPa, 900 MPa, 1 100 MPa and 1 250 MPa corresponds to the minimum tensile stress which the nut is able to withstand at ambient temperature without breaking or cracking when tested with a bolt of a higher strength class.

NOTE 2 120 °C, 235 °C, 425 °C, 315 °C, 650 °C, 730 °C and 600 °C corresponds to the maximum temperature that the nut is able to withstand without permanent alteration to its original characteristics, after ambient temperature has been restored. The maximum temperature is conditioned by the surface treatment.

These nuts are intended to be used with split pins in conformity with ISO 1234.

This International Standard is applicable for the compilation of aerospace product standards.

## 2 Normative references

The following documents, in whole or in part, are normatively referenced in this document and are indispensable for its application. For dated references, only the edition cited applies. For undated references, the latest edition of the referenced document (including any amendments) applies.

ISO 1234, *Split pins*

ISO 5855-2, *Aerospace — MJ threads — Part 2: Limit dimensions for bolts and nuts*

ISO 8788, *Aerospace — Nuts, metric — Tolerances of form and position*

## 3 Configuration and dimensions

See [Figure 1](#) and [Table 1](#). Dimensions and tolerances are expressed in millimetres. They apply after any surface coating(s) but before the application of any lubricant.

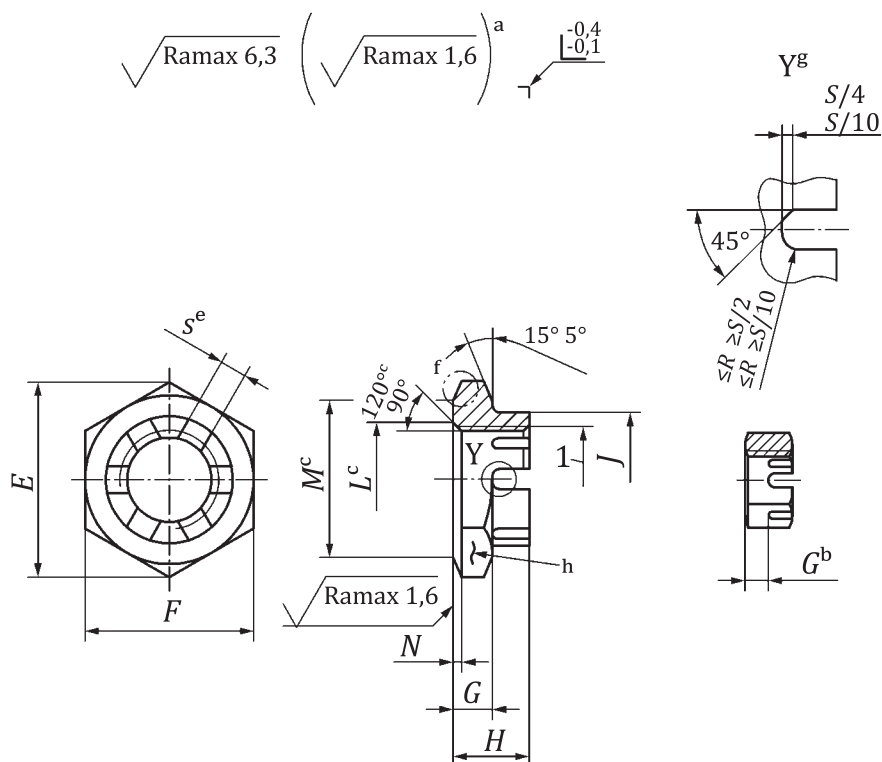

**Key**

- a These values, in micrometres, apply before any surface coating(s) is/are applied. The values do not apply to threads the surface texture of which will be as achieved by the usual manufacturing methods
- b Applies to height below slots and height of flats (diameter codes 060 to 240).
- c This dimension also applies to the upper chamfer. All forms of entry (chamfer or radius) permissible within these limiting dimensions.
- d Diameter  $M$  may be tangential to, but shall not intrude on the flats.
- e 6 slots.
- f Form of contour within limiting dimensions at manufacturer's option
- g (4:1) Form (radius or chamfer) at bottom of slot at manufacturer's option.

NOTE Tolerances of form and position shall conform to those specified in ISO 8788. Details of form not stated are at the manufacturer's discretion.

**Figure 1 — Configurations and dimensions**



**Table 1 — Dimensions**

Dimensions in millimetres

Diameter code	Thread <sup>a</sup>	<i>E</i> min.	<i>F</i>		<i>G</i> h14	<i>H</i> ±0,25	<i>J</i> ±0,25	<i>L</i>		<i>M</i> min	<i>N</i> 0 –0,3	<i>S</i> H14	Maximum split pin diameter <sup>b</sup>
<b>040</b>	MJ4 × 0,7 – 4H6H	7,6	7	h12	2,1	4,1	—	4,2	+0,6 0	6,4	0,5	1,3	1,0
<b>050</b>	MJ5 × 0,8 – 4H6H	8,7	8		2,4	4,8	—	5,2		7,4		1,7	1,4
<b>060</b>	MJ6 × 1 – 4H5H	10,9	10	3,0	5,4	9	6,3	9,3	2,1	1,8			
<b>070</b>	MJ7 × 1 – 4H5H	12,0	11		5,8	10	7,3	10,2	12,2	2,6	2,3		
<b>080</b>	MJ8 × 1 – 4H5H	14,3	13	3,2	6,0	11	8,3	16,0				0,6	3,2
<b>100</b>	MJ10 × 1,25 – 4H5H	18,9	17	4,0	7,6	13	10,3	18,0	4,0	3,7			
<b>120</b>	MJ12 × 1,25 – 4H5H	21,1	19	h13	4,8	8,4	16	12,3			21,0		
<b>140</b>	MJ14 × 1,5 – 4H5H	24,5	22		5,6	10,0	18	14,4	+0,8 0	23,0			
<b>160</b>	MJ16 × 1,5 – 4H5H	26,8	24	6,4	10,8	22	16,4	26,0					
<b>180</b>	MJ18 × 1,5 – 4H5H	30,2	27	7,2	12,4	25	18,4	29,0					
<b>200</b>	MJ20 × 1,5 – 4H5H	33,6	30	8,0	13,2	28	20,4	30,9					
<b>220</b>	MJ22 × 1,5 – 4H5H	35,8	32	8,8	14,0	30	22,4	34,9					
<b>240</b>	MJ24 × 2 – 4H5H	40,4	36	9,6	14,8	32	24,5						

<sup>a</sup> In accordance with ISO 5855-2.

<sup>b</sup> For information, in conformity with ISO 1234 for the split pin maximum diameter but not for the split pin maximum diameter/thread diameter combination.

