

---

---

**Tools for pressing — Guide bushes —**  
**Part 6:**  
**Form E, gliding bushes, flanged, type 1**

*Outillage de presse — Bagues de guidage —*

*Partie 6: Forme E, bagues à collerette à brider pour guidage lisse, type 1*



Reference number  
ISO 9448-6:2013(E)

© ISO 2013



**COPYRIGHT PROTECTED DOCUMENT**

© ISO 2013

All rights reserved. Unless otherwise specified, no part of this publication may be reproduced or utilized otherwise in any form or by any means, electronic or mechanical, including photocopying, or posting on the internet or an intranet, without prior written permission. Permission can be requested from either ISO at the address below or ISO's member body in the country of the requester.

ISO copyright office  
Case postale 56 • CH-1211 Geneva 20  
Tel. + 41 22 749 01 11  
Fax + 41 22 749 09 47  
E-mail [copyright@iso.org](mailto:copyright@iso.org)  
Web [www.iso.org](http://www.iso.org)

Published in Switzerland

# Contents

	Page
<b>Foreword</b> .....	<b>iv</b>
<b>1 Scope</b> .....	<b>1</b>
<b>2 Dimensions</b> .....	<b>1</b>
<b>3 Material</b> .....	<b>3</b>
<b>4 Designation</b> .....	<b>3</b>
<b>Bibliography</b> .....	<b>5</b>

## Foreword

ISO (the International Organization for Standardization) is a worldwide federation of national standards bodies (ISO member bodies). The work of preparing International Standards is normally carried out through ISO technical committees. Each member body interested in a subject for which a technical committee has been established has the right to be represented on that committee. International organizations, governmental and non-governmental, in liaison with ISO, also take part in the work. ISO collaborates closely with the International Electrotechnical Commission (IEC) on all matters of electrotechnical standardization.

The procedures used to develop this document and those intended for its further maintenance are described in the ISO/IEC Directives, Part 1. In particular the different approval criteria needed for the different types of ISO documents should be noted. This document was drafted in accordance with the editorial rules of the ISO/IEC Directives, Part 2. [www.iso.org/directives](http://www.iso.org/directives)

Attention is drawn to the possibility that some of the elements of this document may be the subject of patent rights. ISO shall not be held responsible for identifying any or all such patent rights. Details of any patent rights identified during the development of the document will be in the Introduction and/or on the ISO list of patent declarations received. [www.iso.org/patents](http://www.iso.org/patents)

Any trade name used in this document is information given for the convenience of users and does not constitute an endorsement.

For an explanation on the meaning of ISO specific terms and expressions related to conformity assessment, as well as information about ISO's adherence to the WTO principles in the Technical Barriers to Trade (TBT) see the following URL: [Foreword - Supplementary information](#)

The committee responsible for this document is ISO/TC 29, *Small tools*, Subcommittee SC 8, *Tools for pressing and moulding*.

This second edition results from the reinstatement of ISO 9448-6:1991, which was withdrawn in 2006 and with which it is technically identical.

ISO 9448 consists of the following parts, under the general title *Tools for pressing — Guide bushes*:

- *Part 1: Forms*
- *Part 2: Form A, gliding bushes, plain, type 1*
- *Part 3: Form B, ball cage bushes, plain, type 1*
- *Part 4: Form C, gliding bushes, headed, type 1*
- *Part 5: Form D, ball cage bushes, headed, type 1*
- *Part 6: Form E, gliding bushes, flanged, type 1*
- *Part 7: Form F, ball cage bushes, flanged, type 1*
- *Part 8: Form G, gliding bushes, stepped, type 1*
- *Part 9: Form B, ball cage bushes, plain, type 2*
- *Part 10: Form E, gliding bushes, flanged, type 2*
- *Part 11: Form F, ball cage bushes, flanged, type 2*

# Tools for pressing — Guide bushes —

Part 6:

## Form E, gliding bushes, flanged, type 1

### 1 Scope

This part of ISO 9448 specifies the main dimensions and tolerances, in millimetres, of guide bushes of form E, flanged gliding bushes, type 1, intended for use in press tools and to be mounted in the clamp plate with transition fit and fixed to the plate by means of guide clamps.

It gives guidance on the materials, and specifies the hardness and the designation of bushes in accordance with this part of ISO 9448.

### 2 Dimensions

The dimensions of type 1 flanged gliding bushes (form E) shall conform to the indications of [Figure 1](#) and [Table 1](#).

Details not stated, such as chamfers, radii, lubrication grooves, are left to the manufacturer's discretion.

Surface roughness values in micrometres

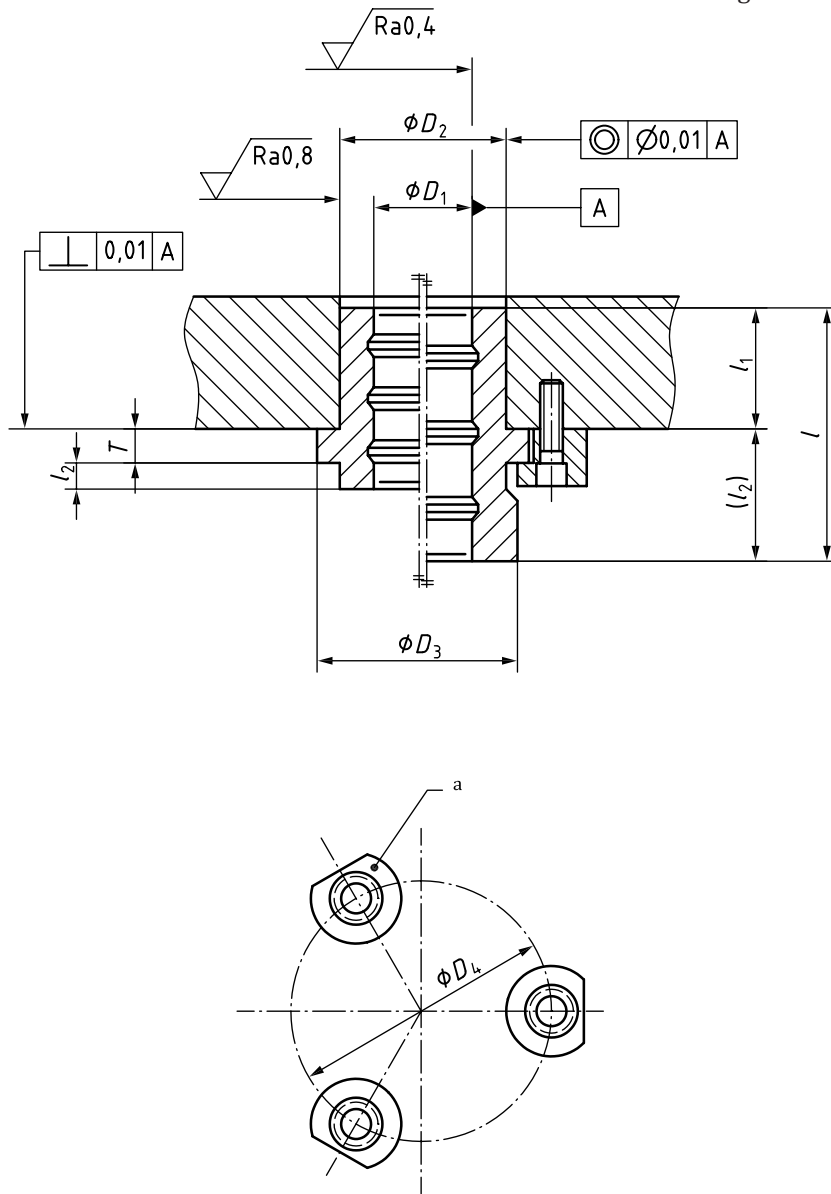

a Number of guide clamps at the manufacturer's discretion.

**Figure 1 — Form E, flanged gliding bushes, type 1**

Table 1

$D_1$	nom.	12		16		20		25		32		40		50		
	tol.	G6												G5		
$D_2$ k5 <sup>a</sup>		22		28		32		40		48		58		70		
$D_3$		30		36		40		48		56		66		80		
$D_4$		47		53		57		65		73		83		97		
$T$ ± 0,1		6,3		6,3		6,3		6,3		6,3		6,3		6,3		
$l_1$	nom.	$l$	$(l_2)$	$l$	$(l_2)$	$l$	$(l_2)$	$l$	$(l_2)$	$l$	$(l_2)$	$l$	$(l_2)$	$l$	$(l_2)$	
	nom.															
20		30	10													
		45	25													
25	-2,0 -2,5	35	10	35	10	37	12	37	12							
		50	25	57	32	45	20	61	36							
32		42	10	42	10	44	12	57	25	44	12					
				64	32	68	36	82	50	77	45					
40				50	10	52	12	52	12	72	32	55	15			
						76	36	80	40	96	56	85	45			
50	-3 -4					62	12	62	12	65	15	82	32	68	18	
								90	40	95	45	113	63	100	50	
63								75	12	78	15	78	15	99	36	
										108	45	113	50	134	71	
80												95	15	98	18	
												130	50	143	63	
100	-3 -5													118	18	
														163	63	

To prevent incorrect assembly of the upper and lower plates of the die set in relation to each other, the following values of  $D_1$  are recommended: 11, 15, 19, 24, 30, 38 and 48.

<sup>a</sup> Intended to fit into a hole having a tolerance of H7.

### 3 Material

The material is left to the manufacturer's discretion and the hardness shall be  $60^{+2}_0$  HRC.

### 4 Designation

A guide bush in accordance with this part of ISO 9448 shall be designated by:

- a) "Guide bush";
- b) a reference to this part of ISO 9448, i.e ISO 9448-6;
- c) its form;

## ISO 9448-6:2013(E)

- d) its guiding diameter,  $D_1$ , in millimetres;
- e) its length,  $l_1$ , in millimetres.
- f) its length,  $l$ , in millimetres.

**EXAMPLE** A guide bush of form E, flanged gliding bush, type 1 of guiding diameter  $D_1 = 12$  mm, of length  $l_1 = 20$  mm and of length  $l = 30$  mm is designated as follows:

**Guide bush ISO 9448-6 E - 12 × 20 × 30**



## Bibliography

- [1] ISO 6508-1, *Metallic materials — Rockwell hardness test — Part 1: Test method*

© ISO 2013. All rights reserved.

