**Continuously hot-rolled stainless steel —
Tolerances on dimensions and form —**

**Part 1:
Narrow strip and cut lengths**

*Acier inoxydable laminé à chaud en continu — Tolérances sur les
dimensions et la forme —*

Partie 1: Bandes étroites et feuillards coupés à longueur



PDF disclaimer

This PDF file may contain embedded typefaces. In accordance with Adobe's licensing policy, this file may be printed or viewed but shall not be edited unless the typefaces which are embedded are licensed to and installed on the computer performing the editing. In downloading this file, parties accept therein the responsibility of not infringing Adobe's licensing policy. The ISO Central Secretariat accepts no liability in this area.

Adobe is a trademark of Adobe Systems Incorporated.

Details of the software products used to create this PDF file can be found in the General Info relative to the file; the PDF-creation parameters were optimized for printing. Every care has been taken to ensure that the file is suitable for use by ISO member bodies. In the unlikely event that a problem relating to it is found, please inform the Central Secretariat at the address given below.



COPYRIGHT PROTECTED DOCUMENT

© ISO 2009

All rights reserved. Unless otherwise specified, no part of this publication may be reproduced or utilized in any form or by any means, electronic or mechanical, including photocopying and microfilm, without permission in writing from either ISO at the address below or ISO's member body in the country of the requester.

ISO copyright office
Case postale 56 • CH-1211 Geneva 20
Tel. + 41 22 749 01 11
Fax + 41 22 749 09 47
E-mail copyright@iso.org
Web www.iso.org

Published in Switzerland

Contents

Page

Foreword.....	iv
1 Scope	1
2 Normative references	1
3 Terms and definitions.....	1
4 Information to be supplied by the purchaser	2
5 Type of delivery and delivery condition	2
6 Tolerances on thickness for hot-rolled narrow strip and cut lengths.....	3
7 Tolerances on width for hot-rolled narrow strip and cut lengths	4
8 Tolerances on length for cut lengths.....	4
9 Tolerances on edge camber for hot-rolled narrow strip and cut lengths	5
10 Tolerances on squareness for cut lengths	5
11 Tolerances on flatness for cut lengths.....	5
12 Form of coils	5
13 Ordered format for cut lengths.....	5
14 Measurement of thickness for hot-rolled narrow strip and cut lengths	5
15 Measurement of width.....	6
16 Measurement of length.....	6
17 Measurement of edge camber	6
18 Measurement of squareness	6
19 Measurement of flatness.....	7
Bibliography	8

Foreword

ISO (the International Organization for Standardization) is a worldwide federation of national standards bodies (ISO member bodies). The work of preparing International Standards is normally carried out through ISO technical committees. Each member body interested in a subject for which a technical committee has been established has the right to be represented on that committee. International organizations, governmental and non-governmental, in liaison with ISO, also take part in the work. ISO collaborates closely with the International Electrotechnical Commission (IEC) on all matters of electrotechnical standardization.

International Standards are drafted in accordance with the rules given in the ISO/IEC Directives, Part 2.

The main task of technical committees is to prepare International Standards. Draft International Standards adopted by the technical committees are circulated to the member bodies for voting. Publication as an International Standard requires approval by at least 75 % of the member bodies casting a vote.

Attention is drawn to the possibility that some of the elements of this document may be the subject of patent rights. ISO shall not be held responsible for identifying any or all such patent rights.

ISO 9444-1 was prepared by Technical Committee ISO/TC 17, *Steel*, Subcommittee SC 4, *Heat treatable and alloy steels*.

This first edition of ISO 9444-1 cancels and replaces the second edition of ISO 9444:2002, the contents of which has been technically revised and separated into two parts.

ISO 9444 consists of the following parts, under the general title *Continuously hot-rolled stainless steel — Tolerances on dimensions and form*:

- *Part 1: Narrow strip and cut lengths*
- *Part 2: Wide strip and sheet/plate*

Continuously hot-rolled stainless steel — Tolerances on dimensions and form —

Part 1: Narrow strip and cut lengths

1 Scope

This part of ISO 9444 specifies the tolerances on dimensions and form for continuously hot-rolled stainless steel narrow strip in actual widths of less than 600 mm. It also applies to cut lengths taken from such strip.

2 Normative references

The following referenced documents are indispensable for the application of this document. For dated references, only the edition cited applies. For undated references, the latest edition of the referenced document (including any amendments) applies.

ISO 6929:1987, *Steel products — Definitions and classification*

3 Terms and definitions

For the purposes of this document, the terms and definitions given in ISO 6929 and the following apply.

3.1

hot-rolled strip

hot-rolled flat product which immediately after the final rolling pass or after pickling or annealing is wound into laps so as to form a coil

NOTE 1 Hot-rolled strip as-rolled has slightly convex edges, but it may also be supplied with sheared edges or be obtained by slitting wider hot-rolled strip.

[ISO 6929:1987, definition 6.2.6.2.2.3.1]

NOTE 2 According to its actual width, including hot-rolled slit strips irrespective of the rolling width, hot-rolled strip is classified as

- hot-rolled wide strip: strip of a width equal to or greater than 600 mm, or
- hot-rolled narrow strip: strip of a width less than 600 mm.

After decoiling and cutting to length, hot-rolled narrow strip may be supplied as cut lengths.

4 Information to be supplied by the purchaser

4.1 It shall be the responsibility of the purchaser to specify all requirements that are necessary for products under this specification. Such requirements to be considered include, in the order listed, but not limited to, the following:

- a) the type of delivery [see 5.1 a) and 5.1 b)];
- b) the number of this part of ISO 9444, i.e. ISO 9444-1;
- c) the thickness, in millimetres (if necessary, accurate to two decimal places);
- d) whether normal tolerances or fine tolerances (F) (see Table 1) of thickness are required;
- e) the width, in millimetres;
- f) the condition of the edges (M = mill edges, T = trimmed edges);
- g) for narrow strip [see 5.1 a)], the condition of the ends [R = mill (rolled) ends, C = cropped ends];
- h) for cut lengths, the length, in millimetres;
- i) any special delivery condition (see 5.2).

EXAMPLE 1 Hot-rolled narrow strip in accordance with this International Standard, with a specified thickness of 2,5 mm, a specified width of 500 mm, with trimmed edges (T) and cropped ends (C):

Hot-rolled narrow strip ISO 9444-1 – 2,5 × 500T-C

EXAMPLE 2 Hot-rolled cut lengths in accordance with this International Standard with a specified thickness of 3,0 mm, fine thickness tolerance (F), a specified width of 100 mm, with trimmed edges (T) and length 1 500 mm:

Hot-rolled cut lengths ISO 9444-1 – 3,0F × 100T × 1500

4.2 In the absence of information in the order concerning special requirements for tolerances on dimension and shape [see 4.1 c) to 4.1 i)], hot-rolled products covered by this part of ISO 9444 will be delivered in accordance with the basic specifications of this part of ISO 9444, i.e. with normal tolerances and/or in the usual delivery condition.

5 Type of delivery and delivery condition

5.1 Type of delivery

Flat products in accordance with this part of ISO 9444 can be supplied as

- a) hot-rolled narrow strip (strip in actual widths less than 600 mm), or
- b) cut lengths [cut from hot-rolled narrow strip in accordance with 5.1 a)].

5.2 Delivery condition

5.2.1 Hot-rolled narrow strip and cut lengths covered by this part of ISO 9444 are supplied in the as-rolled (U) condition, unless the annealed and/or descaled condition has been agreed upon.

5.2.2 Hot-rolled narrow strip is usually supplied with mill (as-rolled) edges. Delivery with trimmed (slit) edges shall be by special agreement.

5.2.3 Hot-rolled cut lengths are usually supplied with trimmed (slit) edges. This is because hot-rolled narrow strip is usually supplied with mill edges, whereas cut lengths are usually supplied with trimmed edges.

5.3 General information

In the absence of agreements at the time of enquiry and order concerning special requirements for the delivery condition given in 5.2, flat products covered by this part of ISO 9444 will be delivered in accordance with the basic specifications of this part of ISO 9444.

6 Tolerances on thickness for hot-rolled narrow strip and cut lengths

6.1 The tolerances on thickness, which include crown, are given in Table 1.

Table 1 — Tolerances on specified thickness for hot-rolled narrow strip and cut lengths

Dimensions in millimetres

Specified thickness t	Tolerances on specified thickness ^a			
	Normal tolerances ^{b, c}		Fine tolerances ^{b, c}	
	Category A	Category B	Category FA	Category FB
$0,80 \leq t \leq 1,50$	$\pm 0,21$	$\pm 0,23$	$\pm 0,12$	$\pm 0,13$
$1,50 < t \leq 2,0$	$\pm 0,22$	$\pm 0,24$	$\pm 0,14$	$\pm 0,16$
$2,0 < t \leq 2,5$	$\pm 0,23$	$\pm 0,25$	$\pm 0,16$	$\pm 0,17$
$2,5 < t \leq 3,0$	$\pm 0,26$	$\pm 0,28$	$\pm 0,16$	$\pm 0,17$
$3,0 < t \leq 4,0$	$\pm 0,29$	$\pm 0,31$	$\pm 0,16$	$\pm 0,17$
$4,0 < t \leq 5,0$	$\pm 0,31$	$\pm 0,34$	$\pm 0,17$	$\pm 0,18$
$5,0 < t \leq 6,0$	$\pm 0,34$	$\pm 0,36$	$\pm 0,18$	$\pm 0,20$
$6,0 < t \leq 8,0$	$\pm 0,38$	$\pm 0,41$	$\pm 0,19$	$\pm 0,21$
$8,0 < t \leq 10,0$	$\pm 0,42$	$\pm 0,45$	$\pm 0,21$	$\pm 0,23$
$10,0 < t \leq 13,0$	$\pm 0,46$	$\pm 0,49$	$\pm 0,23$	$\pm 0,25$
$t > 13,0$	The tolerances have to be agreed upon at the time of enquiry and order.			
^a Trimmed edges or sheared ends may have burrs.				
^b Tolerances of category A and FA apply to all grades except those covered by the exception in footnote c.				
^c Tolerances of category B and FB apply to stainless steel types with Ni > 20 % or Mo > 2 % or N > 0,10 %.				

6.2 The specified fine tolerances on thickness for hot-rolled narrow strip are only valid for deliveries of more than two coils of the same steel grade and same nominal dimensions. For smaller deliveries, a special agreement shall be made at the time of ordering.

The fine tolerances on thickness for cut lengths are valid, regardless of the quantities supplied.

6.3 If required for hot-rolled narrow strip intended for cold rolling, the difference in thickness throughout one coil shall not exceed the values given in Table 2.

These requirements are not applicable at the beginning and at the end of the coil over a length of 3 m.

6.4 If the purchaser requires tolerances on crown tighter than those implicit in the tolerance on thickness, the tolerances on crown shall be subject to agreement between the manufacturer and purchaser, and shall be specified on the purchase order.

Table 2 — Permitted thickness differences within one coil ^a for hot-rolled narrow strip intended for cold rolling

Dimensions in millimetres

Specified thickness <i>t</i>	Permitted thickness differences	
	Normal tolerances Categories A and B ^b	Fine tolerances Categories FA and FB ^b
$t \leq 2,0$	0,20	0,14
$2,0 < t \leq 3,0$	0,22	0,14
$3,0 < t \leq 4,0$	0,28	0,14
$4,0 < t \leq 8,0$	0,28	0,17
$8,0 < t \leq 13,0$	0,28	—

^a The thickness (within one coil) shall change gradually and shall not occur with visible discontinuity.
^b Concerning Categories A, B, FA and FB, see Table 1, footnotes b and c.

7 Tolerances on width for hot-rolled narrow strip and cut lengths

7.1 The tolerances on width for hot-rolled narrow strip and cut lengths with mill (as-rolled) edges shall be 0/+ 15 mm, unless otherwise agreed.

7.2 The tolerances on width for hot-rolled narrow strip and cut lengths with trimmed (slit) edges are given in Table 3.

Table 3 — Tolerances on width for hot-rolled narrow strip and cut lengths with trimmed (slit) edges

Dimensions in millimetres

Specified width <i>w</i>	Tolerances on width for specified thicknesses <i>t</i> of				
	$t \leq 3,0$	$3,0 < t \leq 5,0$	$5,0 < t \leq 7,0$	$7,0 < t \leq 8,0$	$8,0 < t \leq 13,0$
$w < 250$	+0,5 0	+0,7 0	+0,8 0	+1,2 0	+1,8 0
$250 \leq w \leq 600$	+0,6 0	+0,8 0	+1,0 0	+1,4 0	+2,0 0

8 Tolerances on length for cut lengths

The tolerances on length for cut lengths are given in Table 4.

Table 4 — Length tolerances for cut lengths

Dimensions in millimetres

Specified length, <i>l</i>	Tolerances
$l < 2\ 000$	+10 0
$2\ 000 \leq l < 20\ 000$	+0,005 0 × specified length
$l \geq 20\ 000$	To be agreed

9 Tolerances on edge camber for hot-rolled narrow strip and cut lengths

9.1 For cut lengths of thicknesses < 2 mm and for strip of all thicknesses, the tolerance on edge camber shall be agreed upon at the time of ordering.

9.2 For cut lengths of thicknesses ≥ 2 mm, the tolerances on edge camber relative to a standard length of 2 500 mm shall be as follows:

- 20 mm for cut lengths of widths $w < 40$ mm;
- 10 mm for cut lengths of widths $40 \text{ mm} \leq w < 600$ mm.

9.3 For cut lengths of lengths other than standard 2 500 mm, the tolerance on edge camber shall be calculated on the basis of the following formula, with the result being rounded to the next highest millimetre:

$$\text{Tolerance on edge camber} = \frac{(\text{Non-standard length in mm})^2}{(2\,500)^2} \times \text{Tolerance on edge camber defined in 9.2}$$

10 Tolerances on squareness for cut lengths

The out-of-squareness for cut lengths shall not exceed 1 % of the specified width of the product.

11 Tolerances on flatness for cut lengths

The flatness tolerance for cut lengths, measured on any 2 000 mm or less of length, shall be 15 mm.

12 Form of coils

The coils delivered in accordance with this part of ISO 9444 shall be tightly wound, as round as possible.

The edges of the coil are permitted to show a gradual displacement to one side which shall not exceed 35 mm in the case of trimmed (slit) edges and 70 mm in the case of mill (as-rolled) edges.

13 Ordered format for cut lengths

13.1 Except as described in 13.2, cut lengths shall conform to the thickness, width, length, edge camber and out-of-squareness tolerances shown in the applicable tables and text.

13.2 By agreement at the time of enquiry and order, the tolerances on squareness and edge camber may be replaced by the requirement that a perfect rectangle formed by the ordered width and length dimensions can be superimposed on the products delivered.

14 Measurement of thickness for hot-rolled narrow strip and cut lengths

14.1 For products of widths up to 30 mm, the thickness is measured at any point on the longitudinal axis. For products of widths greater than 30 mm, it is measured at any point at least 10 mm or 15 mm from the longitudinal edges, depending on whether they are trimmed (slit) or mill (as-rolled) edges.

14.2 The measurements shall be taken at least 3 000 mm from the ends of coils with end tongues, and at least 2 000 mm for coils without end tongues.

14.3 The measuring points for determining the crown (see 6.4) shall be on a line running perpendicular to the longitudinal axis of the product.

14.4 The difference in thickness within one coil (see 6.3) shall be measured on a line running parallel to the edge of the narrow strip at least 15 mm from it.

15 Measurement of width

The width is measured perpendicularly to the rolling direction of the product and outside the area of any end tongues.

16 Measurement of length

The length of cut lengths is measured along one of the longer edges of the product.

17 Measurement of edge camber

17.1 Edge camber is the greatest deviation of a side edge from a straight line, the measurement being taken on the concave side with a straight-edge (see Figure 1).

17.2 Edge camber is not normally measured by the manufacturer, unless compliance is in doubt.

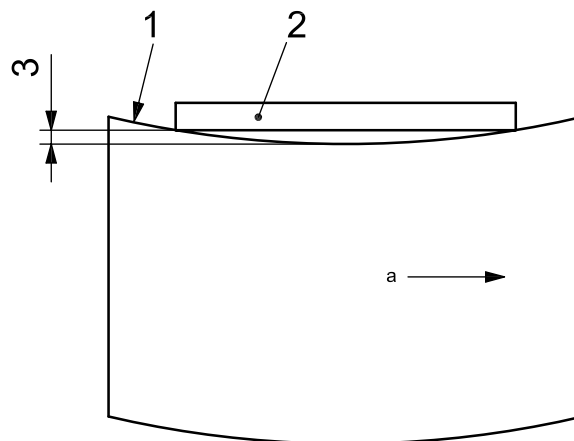

Key

- 1 side edge (concave side)
- 2 straight-edge
- 3 edge camber
- a Rolling direction.

Figure 1 — Measurement of edge camber

18 Measurement of squareness

18.1 Out-of-square is the greatest deviation of an end edge from a straight edge of a square placed at right angles to a side and touching one corner (see Figure 2).

18.2 The out-of-squareness is not normally measured by the manufacturer, unless compliance is in doubt.

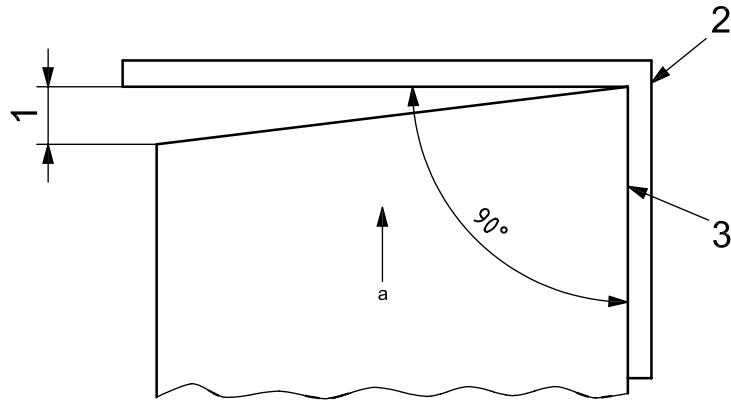
**Key**

- 1 out-of-square
- 2 square
- 3 side edge
- ^a Rolling direction.

Figure 2 — Measurement of out-of-squareness

19 Measurement of flatness

19.1 Verification of flatness tolerances, if required, shall be measured in the following way.

For a maximum deviation from a flat horizontal surface, with the product lying under its own mass on a flat surface, the maximum deviation from flatness is the maximum distance between the lower surface of the product and the flat horizontal surface.

19.2 Flatness is not normally measured by the manufacturer, unless compliance is in doubt.

Bibliography

- [1] ISO 9444-2, *Continuously hot-rolled stainless steel — Tolerances on dimensions and form — Part 2: Wide strip and sheet/plate*
- [2] ISO 18286, *Hot-rolled stainless steel plates — Tolerances on dimensions and shape*

