**Wood-based panels — Determination of
dimensions of test pieces**

*Panneaux à base de bois — Détermination des dimensions des
échantillons*



PDF disclaimer

This PDF file may contain embedded typefaces. In accordance with Adobe's licensing policy, this file may be printed or viewed but shall not be edited unless the typefaces which are embedded are licensed to and installed on the computer performing the editing. In downloading this file, parties accept therein the responsibility of not infringing Adobe's licensing policy. The ISO Central Secretariat accepts no liability in this area.

Adobe is a trademark of Adobe Systems Incorporated.

Details of the software products used to create this PDF file can be found in the General Info relative to the file; the PDF-creation parameters were optimized for printing. Every care has been taken to ensure that the file is suitable for use by ISO member bodies. In the unlikely event that a problem relating to it is found, please inform the Central Secretariat at the address given below.

© ISO 2003

All rights reserved. Unless otherwise specified, no part of this publication may be reproduced or utilized in any form or by any means, electronic or mechanical, including photocopying and microfilm, without permission in writing from either ISO at the address below or ISO's member body in the country of the requester.

ISO copyright office
Case postale 56 • CH-1211 Geneva 20
Tel. + 41 22 749 01 11
Fax + 41 22 749 09 47
E-mail copyright@iso.org
Web www.iso.org

Published in Switzerland

Foreword

ISO (the International Organization for Standardization) is a worldwide federation of national standards bodies (ISO member bodies). The work of preparing International Standards is normally carried out through ISO technical committees. Each member body interested in a subject for which a technical committee has been established has the right to be represented on that committee. International organizations, governmental and non-governmental, in liaison with ISO, also take part in the work. ISO collaborates closely with the International Electrotechnical Commission (IEC) on all matters of electrotechnical standardization.

International Standards are drafted in accordance with the rules given in the ISO/IEC Directives, Part 2.

The main task of technical committees is to prepare International Standards. Draft International Standards adopted by the technical committees are circulated to the member bodies for voting. Publication as an International Standard requires approval by at least 75 % of the member bodies casting a vote.

Attention is drawn to the possibility that some of the elements of this document may be the subject of patent rights. ISO shall not be held responsible for identifying any or all such patent rights.

ISO 9424 was prepared by Technical Committee ISO/TC 89, *Wood-based panels*.

This second edition is based on European Standard EN 325. It cancels and replaces the first edition (ISO 9424:1989) which has been modified to include a range of anvil diameters for the thickness measurement.

Wood-based panels — Determination of dimensions of test pieces

1 Scope

This International Standard specifies a method for measuring the thickness, length and width of test pieces of wood-based panels.

2 Normative references

The following referenced documents are indispensable for the application of this document. For dated references, only the edition cited applies. For undated references, the latest edition of the referenced document (including any amendments) applies.

ISO 16999, *Wood-based panels — Sampling and cutting of test pieces*

3 Principle

The thickness, length and width of the test piece are determined by linear measurement.

4 Apparatus

4.1 Micrometer or similar measuring instrument, for thickness measurement, having flat and parallel circular anvils of diameter between 6,0 mm and 20,0 mm and an operating pressure between 0,02 MPa and 0,05 MPa. The graduation of the apparatus shall allow reading to 0,01 mm.

The anvil diameter selected will depend on the panel type. In principle, panels of low density and/or uneven surface should be measured using the larger anvil diameter.

4.2 Sliding caliper or any other instrument, for length and width measurement, with measuring surfaces of at least 5 mm width, graduated to allow a reading to 0,1 mm.

5 Test pieces

5.1 Sampling and cutting

Sampling and cutting of the test pieces shall be carried out in accordance with ISO 16999.

5.2 Dimensions

The dimensions of the test pieces shall be in accordance with those specified in the relevant test method.

5.3 Conditioning

The test pieces shall be conditioned to constant mass in an atmosphere with a relative humidity of $(65 \pm 5) \%$ and a temperature of $(20 \pm 2) ^\circ\text{C}$. Constant mass is considered as having been reached when the results of two successive weighing operations, carried out at an interval of 24 h, do not differ by more than 0,1 % of the mass of the test piece.

6 Procedure

6.1 Measuring points

The number and positions of the measuring points shall be in accordance with the relevant International Standard for test methods.

6.2 Thickness measurement

For measuring the thickness, apply the surfaces of the measuring instrument (4.1) slowly to the test piece. Measure the thickness to 0,01 mm.

6.3 Length and width measurement

For measuring the length and width, apply the jaw of the sliding caliper (4.2) slowly and without excessive pressure to the test piece, at an angle of approximately 45° to the plane of the test piece (see Figure 1).

Measure the length and width to the nearest 0,1 mm.

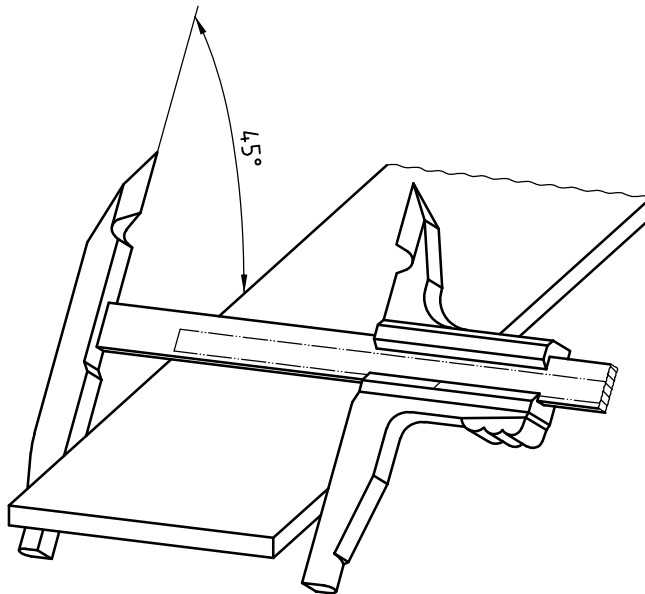

Figure 1 — Inclination of sliding caliper to plane of test piece

7 Test report

The test report shall contain the following information:

- name and address of the test laboratory;
- sampling report according to ISO/FDIS 16999;
- date of the test report;
- reference to this International Standard;
- type and thickness of the panel;
- relevant product specification;
- surface treatment, if relevant;
- specific apparatus used, in case of different possibilities allowed in this International Standard;
- test results, expressed to the nearest 0,01 mm for thickness and to the nearest 0,1 mm for length and width measurement;
- all deviations from this International Standard.

