

# INTERNATIONAL STANDARD

**ISO**  
**9404-1**

First edition  
1991-09-01

---

---

## **Enclosures for protection against ionizing radiation — Lead shielding units for 150 mm, 200 mm and 250 mm thick walls —**

### **Part 1 : Chevron units of 150 mm and 200 mm thickness**

*Enceintes pour la protection contre les rayonnements ionisants — Éléments de  
blindage en plomb pour murs de 150 mm, 200 mm et 250 mm d'épaisseur —*

*Partie 1 : Éléments à chevrons de 150 mm et 200 mm d'épaisseur*



Reference number  
ISO 9404-1 : 1991 (E)

## Contents

Page

### Section 1 : General

1.1	Scope .....	1
1.2	Classification .....	1
1.3	Designation .....	1
1.3.1	Explanation of the reference number .....	2
1.3.2	Explanation of a designation example .....	2
1.4	Specifications of the bricks .....	2
1.4.1	General .....	2
1.4.2	Property of the material .....	3
1.4.3	Profile of the chevron .....	3

### Section 2 : Lead shielding units — Thickness 150 mm

2.1	Categories 1 and 2 .....	5
2.1.1	Plain bricks .....	5
2.1.2	Corner bricks .....	6
2.1.3	End bricks .....	7
2.1.4	Special bricks .....	7
2.1.5	Posts .....	8
2.1.6	Assembly of basic units .....	8
2.1.7	Aperture bricks .....	10

© ISO 1991

All rights reserved. No part of this publication may be reproduced or utilized in any form or by any means, electronic or mechanical, including photocopying and microfilm, without permission in writing from the publisher.

International Organization for Standardization  
Case postale 56 • CH-1211 Genève 20 • Switzerland

Printed in Switzerland

2.1.8	Windows .....	12
2.1.9	Sphere units .....	17
2.1.10	Plugs .....	18
2.1.11	Reducing units .....	19
2.1.12	Assembly of functional units .....	20
2.2	Category 3 .....	23
2.2.1	Plain bricks .....	23
2.2.2	Corner bricks .....	23
<b>Section 3 : Lead shielding units — Thickness 200 mm</b>		
3.1	Categories 1 and 2 .....	24
3.1.1	Basic units and assembly of walls for enclosures of 200 mm thickness ..	24
3.1.2	Posts .....	24
3.1.3	Aperture bricks .....	26
3.1.4	Windows .....	29
3.1.5	Sphere units .....	34
3.1.6	Plugs .....	35
3.1.7	Reducing units .....	36
3.1.8	Assembly of functional units .....	38
<b>Section 4 : Tolerances</b>		
4.1	Tolerances .....	41
<b>Annex</b>		
A	Bibliography .....	44

## Foreword

ISO (the International Organization for Standardization) is a worldwide federation of national standards bodies (ISO member bodies). The work of preparing International Standards is normally carried out through ISO technical committees. Each member body interested in a subject for which a technical committee has been established has the right to be represented on that committee. International organizations, governmental and non-governmental, in liaison with ISO, also take part in the work. ISO collaborates closely with the International Electrotechnical Commission (IEC) on all matters of electrotechnical standardization.

Draft International Standards adopted by the technical committees are circulated to the member bodies for voting. Publication as an International Standard requires approval by at least 75 % of the member bodies casting a vote.

International Standard ISO 9404-1 was prepared by Technical Committee ISO/TC 85, *Nuclear energy*, Sub-Committee SC 2, *Radiation protection*.

ISO 9404 will consist of the following parts, under the general title *Enclosures for protection against ionizing radiation — Lead shielding units for 150 mm, 200 mm and 250 mm thick walls*:

- *Part 1: Chevron units of 150 mm and 200 mm thickness*
- *Part 2: Rounded units of 150 mm, 200 mm and 250 mm thickness*

Annex A of this part of ISO 9404 is for information only.

# Enclosures for protection against ionizing radiation — Lead shielding units for 150 mm, 200 mm and 250 mm thick walls —

## Part 1 : Chevron units of 150 mm and 200 mm thickness

### Section 1 : General

#### 1.1 Scope

This part of ISO 9404 specifies the properties of the various lead units used in the construction of shielded enclosures for protection against ionizing radiation. The units dealt with are:

- basic units: bricks, posts;
- functional units: aperture bricks, windows, sphere units, plugs and reducing units.

Only bricks for walls of 150 mm thickness are standardized in this part of ISO 9404. Since four- and five-chevron bricks are not manufactured, 200 mm and 250 mm thick walls are constructed with bricks of 50 mm, 100 mm and 150 mm thickness.

The 150 mm and 200 mm shielding units are dealt with separately in two sections for clarity. The 50 mm and 100 mm shielding units are standardized in ISO 7212.

#### 1.2 Classification

The units described in this part of ISO 9404 are classified in three categories:

- **Category 1:** standardized units.

(The diagrams in figures 7, 15, 28 represent the standardized units in category 1.)

- **Category 2:** these are units which are either used very infrequently or for very specialized purposes, or are used very frequently in one country and it is felt that this use will become more widespread.

(The diagrams in figures 16 and 29 represent the standardized units in category 2.)

- **Category 3:** units which are acceptable for a transition period. These are units which are used in one or a few countries and which will be withdrawn from this part of ISO 9404 after the transition period. This category may also include units which were in category 2, but which became less important and will be withdrawn after a transition period in category 3.

#### 1.3 Designation

The designation of the lead shielding unit consists of its name written in full, the reference to this part of ISO 9404 and the reference number as explained in 1.3.1.

EXAMPLE

Aperture brick ISO 9404-1 3V0 202

**1.3.1 Explanation of the reference number**

The reference number consists of a figure, a letter followed by another figure and a group of three figures, for example 3V0 202:

- a) 1st figure: lead thickness  
3 = 150 mm      4 = 200 mm
- b) letter: encasing profile  
V = with chevrons      R = rounded form

NOTE — In this part of ISO 9404, only the chevron shielding units are standardized.

- c) 2nd figure: assembly direction  
1 = assembly direction 1 (see 1.4)  
2 = assembly direction 2 (see 1.4)  
0 = two assembly directions
- d) 3rd, 4th and 5th figures: number specific to each unit.

**NOTES**

1 A unit which has two different positions inside the shielding wall has the same reference but, according to its position in the wall, the name of its type is different. For example: the base plain brick and the left-hand end ordinary brick have the same reference number: 3V0 100.

- 2 Throughout the text, it is understood that
  - a plain brick is any module of brick having 100 mm × 100 mm dimensions inserted in a wall, which is neither end, corner, nor special;
  - an ordinary brick is any module of brick which is neither base nor top.

Except for the cases mentioned in note 2, the last three figures are fixed in series according to table 1.

**Table 1 — Series allocation**

Units	Series
Plain bricks	100 to 119
Corner bricks	120 to 149
End bricks	150 to 159
Square bricks	170 to 179
X bricks	180 to 189
Posts	190 to 199
Circular aperture bricks	200 to 219
Square or rectangular aperture bricks	250 to 269
Circular windows	300 to 319
Square and rectangular windows	350 to 369
Sphere units	400 to 419
Plugs	500 to 519
Reducing units	600 to 619

In each of these series, a serial number is given to all the units (for example, 3V0 101, 3V0 102, etc.).

1) The dimensions of bricks may vary by a half module.

**1.3.2 Explanation of a designation example**

Lead circular aperture brick, 150 mm thickness, three chevrons, two assembly directions, No. 202 (300 mm × 300 mm) shall be designated as follows:

**Aperture brick ISO 9404-1 3V0 202**

**1.4 Specifications of the bricks**

**1.4.1 General**

The dimensions of the category 1 and 2 bricks have been standardized in order to ensure a 100 mm by 100 mm module<sup>1)</sup> on installation and, if necessary, to allow staggered joints [see figure 1 a)].

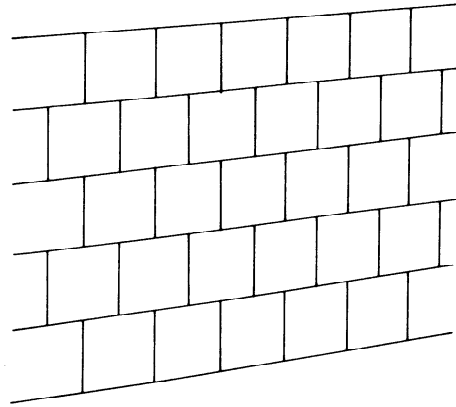

**a) Staggered joints**

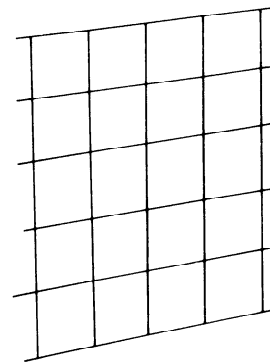

**b) Straight joints**

**Figure 1 — Assembly of bricks**

The bricks have two assembly directions (see figure 2):

- assembly direction 1: chevron pointing upwards to the right
  - assembly direction 2: chevron pointing upwards to the left
- } Looking at the enclosure from the outside

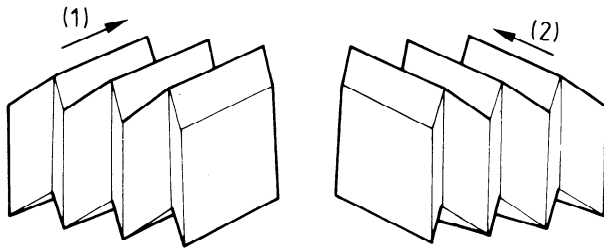

Figure 2 — Assembly directions of bricks

It is recommended that the same assembly direction be used for the entire shielding wall but, if it proves necessary to use the reverse direction, special bricks are used for the join (see 2.1).

A diagram of the basic units of category 1 is given in figure 7.

### 1.4.2 Properties of the material

The units are made out of an antimonial lead alloy, but they are commonly designated as "lead shielding units".

The surface roughness of the faces is  $R_a$  quality 2,8 or better (see ISO 468 and ISO 1302), to give the surface finish required for facilitating decontamination. There shall be no cavities.

The properties of the lead used for the bricks are given in table 2.

Table 2 — Properties of the material

Minimum density of the lead	Percentage of antimony	Minimum hardness
10,9 g/cm <sup>3</sup> 1)	4 ± 0,5	9,5 HB <sup>2)</sup>
1) This value is not the theoretical value, but that obtained by direct measurement at 20 °C on commercially available units.		
2) The value of 9,5 HB is the minimum which shall be obtained at any point on the brick immediately after casting. The Brinell hardness increases in the first few months after manufacture.		

### 1.4.3 Profile of the chevron

The specifications relating to the chevron are given in table 3. Figure 3 shows an example of a three-chevron brick.

Table 3 — Specifications of a chevron

Angle of the chevron		Thickness $e$ mm	Tolerance on height $H$ and length $L$ mm	Angle on face
Male	Female			
$90^\circ + 15'$ 0	$90^\circ - 0'$ -15'	$50 - 0,5$	±0,2	$90^\circ \pm 10'$

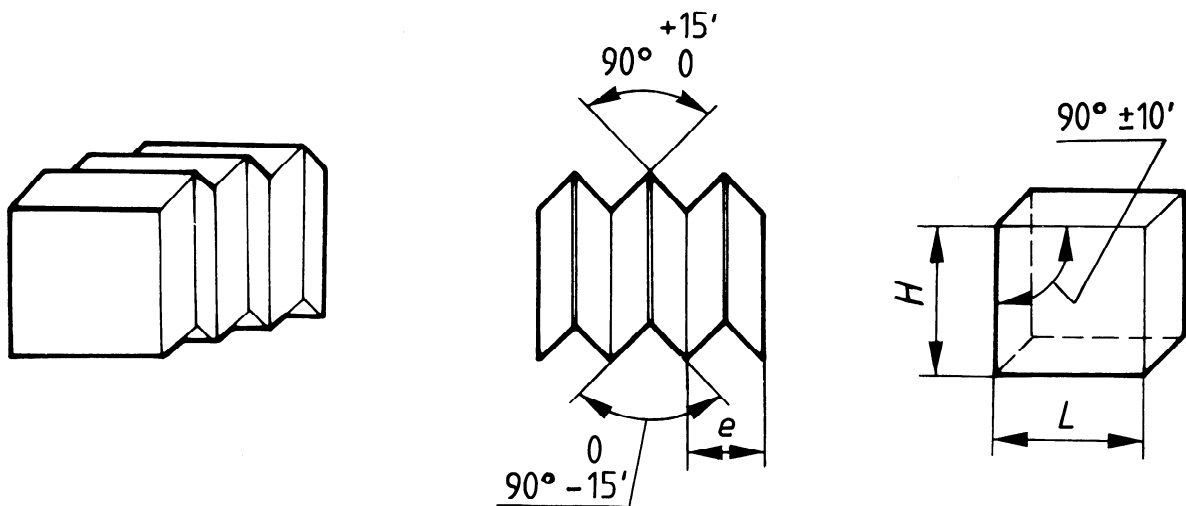

Figure 3 — Example of a three-chevron ordinary plain brick

Bricks with four chevrons are not manufactured except for functional units.

All other parts of a 200 mm thick wall comprise combinations of one-, two- or three-chevron bricks (see figure 4).

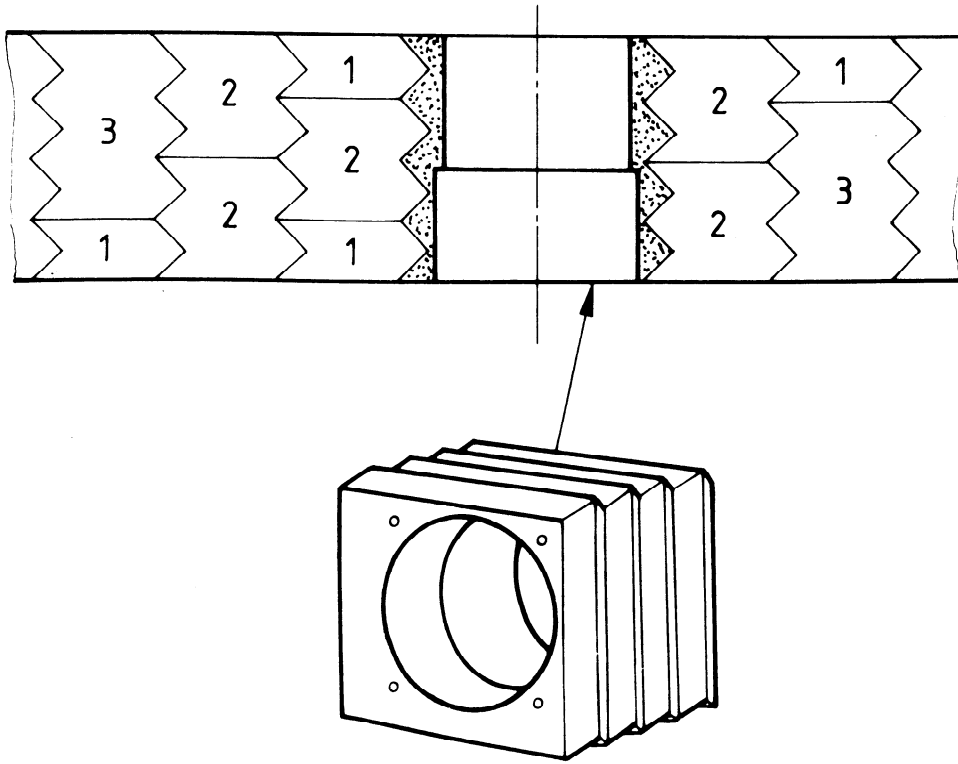

Figure 4 – Example of functional unit with four chevrons – Aperture brick



## Section 2 : Lead shielding units — Thickness 150 mm

### 2.1 Categories 1 and 2

A 150 mm thick wall may be built with three-chevron plain units (see table 4) or, alternatively, by using a combination of one-chevron and two-chevron plain units. For reasons of stability, it is recommended that three-chevron base bricks only be used at the base of a 150 mm thick wall.

Because of their limited use, neither 1/4 plain ordinary bricks nor 1/4 plain top bricks are manufactured with a three-chevron

profile. To compensate for this, a combination of one-chevron and two-chevron 1/4 plain ordinary bricks may be used.

#### 2.1.1 Plain bricks

Each type of plain brick may be assembled in each of the two assembly directions.

Table 4 shows the standardized dimensions of category 1, three-chevron plain bricks. The unit module for the designation of bricks is 100 mm × 100 mm.

Table 4 — Category 1 plain bricks

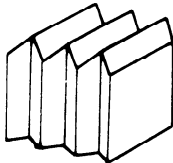
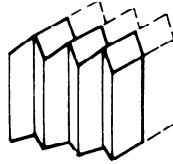
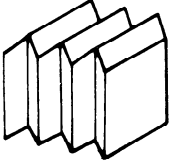
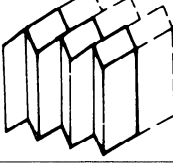
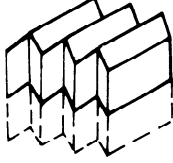
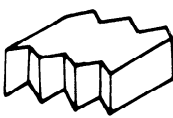
Type	Reference number	Dimensions mm		Diagram	Approximate mass kg
		<i>H</i>	<i>L</i>		
Base plain brick <sup>1)</sup>	3V0 100	100	100		19
1/2 base plain brick <sup>2)</sup>	3V0 101	100	50		9
Ordinary plain brick	3V0 102	100	100		16
1/2 ordinary plain brick <sup>3)</sup>	3V0 103	100	50		8
		50	100		
1/2 top plain brick <sup>4)</sup>	3V0 105	50	100		6

1) Identical to the 100 × 100 left-hand ordinary end brick (see table 6).

2) Identical to the 50 × 100 1/2 left-hand ordinary end brick (see table 6).

3) This brick may be turned round to constitute an ordinary plain brick 50 mm high and 100 mm long.

4) Identical to the 100 × 50 1/2 right-hand ordinary end brick (see table 6).

2.1.2 Corner bricks

The dimensions of category 1, three-chevron corner bricks are given in table 5.

Because of their limited use, 1/2 ordinary corner bricks with a three-chevron profile are not manufactured. To compensate for this, a combination of a 1/2 one-chevron corner brick and a 1/2 two-chevron corner brick may be used.

Table 5 – Category 1 corner bricks

Type	Reference number	Dimensions mm			Diagram	Assembly direction*)	Approximate mass kg
		H	L <sub>1</sub> Re-entrant chevron	L <sub>2</sub> Projecting chevron			
Base corner brick	3V1 120	100	200	150		37	
Base corner brick	3V2 121	100	200	150		37	
Ordinary corner brick	3V1 122	100	200	150		33	
Ordinary corner brick	3V2 123	100	200	150		33	
1/2 top corner brick	3V1 126	50	200	150		12	
1/2 top corner brick	3V2 127	50	200	150		12	

\*) The assembly direction indicated is for convex angle enclosures. For a concave (or reflex) angle :

- either reverse the assembly direction using the same type of corner brick; or
- keep the same assembly direction using the opposite type of corner brick.

See detail on assembly directions in figure 2 and the general diagram in figure 7.

### 2.1.3 End bricks

Left-hand end bricks for assembly direction 1, when reversed, also serve as right-hand end bricks for assembly direction 2.

Because of their limited use, base end and top end bricks with a three-chevron profile are not manufactured. To compensate for this, a combination of one-chevron and two-chevron base end and top end bricks may be used.

The dimensions of the end bricks for assembly direction 1 are given in table 6.

**Table 6 — Category 1 end bricks**

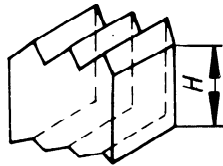
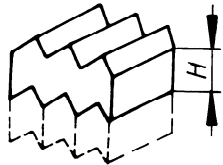
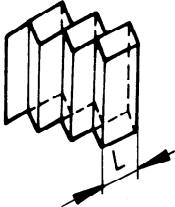
Type	Reference number	Dimensions mm		Diagram	Approximate mass kg
		H	L		
Left-hand ordinary end brick <sup>1)</sup>	3V0 100	100	100		19
1/2 left-hand ordinary end brick <sup>2)</sup>	3V0 101	50	100		9
1/2 right-hand ordinary end brick <sup>3)</sup>	3V0 105	100	50		6
<p>1) Identical to the 100 × 100 base plain brick (see table 4).            2) Identical to the 100 × 50 1/2 base plain brick (see table 4).            3) Identical to the 50 × 100 1/2 top plain brick (see table 4).</p>					

### 2.1.4 Special bricks

Special bricks are used to reverse the assembly direction and are made for walls of 50 mm lead thickness; for walls of 150 mm thickness, three special bricks are used side by side.

There are two types of special bricks: square bricks and X bricks, the assembly directions of which are shown in figures 5 and 6, respectively.

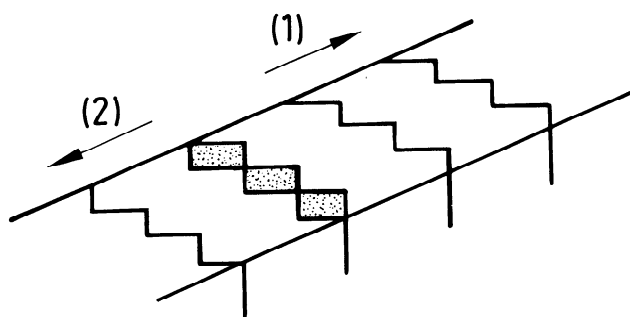

**Figure 5 — Assembly of square bricks**

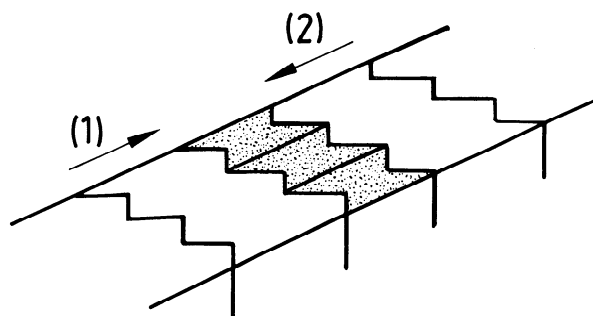

**Figure 6 — Assembly of X bricks**

**2.1.5 Posts**

Posts are used to provide a framework for the brick enclosures.

When used, external tie rods and rigid angle bars can be attached.

These posts have a maximum height of 3 m; they are made either of antimoniated lead or soft lead cast on a steel frame.

**Table 7 – Category 2 posts (assembly direction 1)<sup>1)</sup>**

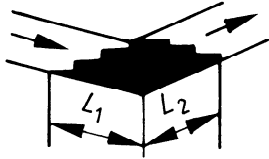
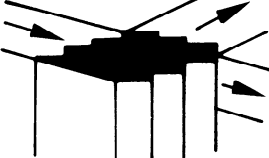
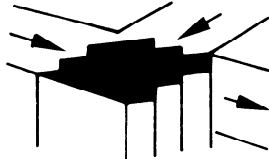
Type	Reference number	Section mm		Diagram	Approximate mass kg
		$L_1$ Re-entrant chevron	$L_2$ Projecting chevron		
Corner post	3V0 190	150	150		250
T-post 2MF (2 male, 1 female)	3V0 191	150	150		270
T-post 2FM (2 female, 1 male)	3V0 192	150	150		230
1) By turning these posts upside down, assembly direction 2 is obtained.					

**2.1.6 Assembly of basic units**

A general diagram of the disposition of the basic units, 150 mm thick, is shown in figure 7 for the units of category 1.



2.1.7 Aperture bricks

Externally, three-chevron aperture bricks are square or rectangular and their internal dimensions are standardized so that the units they hold may be interchanged (see figures 8 and 9).

The dimensions of aperture bricks for a lead thickness of 150 mm are given in tables 8, 9, 10 and 11.

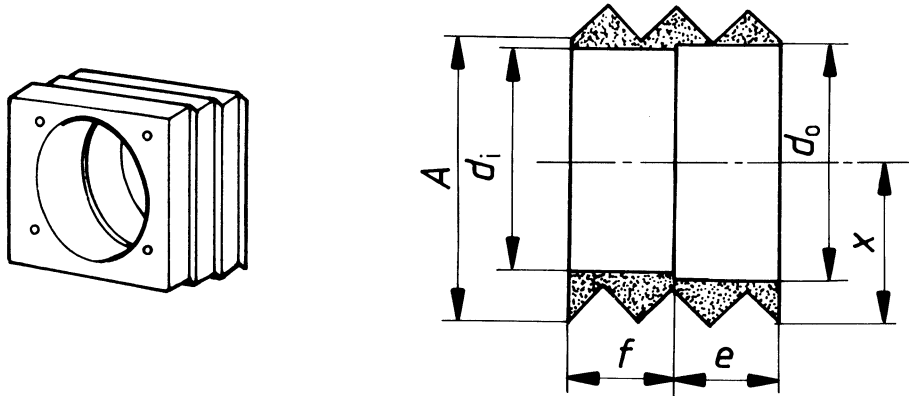

Figure 8 — Aperture brick for circular units

Table 8 — Category 1 aperture bricks for circular units

Reference number	$A \times A$	$x$	$d_i$	$d_o$	$e$	$f$	Approximate mass kg
	mm						
3V0 200	200 × 200	112,5	170	172	72	76,25	30
3V0 202	300 × 300	162,5	266	270	70	76,5	50
3V0 204	400 × 400	212,5	366	370	70	76,5	90

NOTE — If, in special cases, an aperture brick is turned through 180° around the axis of the aperture to change the direction of assembly, it should be noted that, taking into account the chevron, the centreline of the aperture is offset 25 mm from the centreline of the face of the brick.

Table 9 — Category 2 aperture bricks for circular units

Reference number	$A \times A$	$x$	$d_i$	$d_o$	$e$	$f$	Approximate mass kg
	mm						
3V0 207	200 × 200	112,5	150	160	75	75	30
3V0 209	250 × 250	137,5	195	205	75	75	50
3V0 211	300 × 300	162,5	240	250	75	75	70
3V0 213	350 × 350	187,5	285	295	75	75	110

NOTE — If, in special cases, an aperture brick is turned through 180° around the axis of the aperture to change the direction of assembly, it should be noted that, taking into account the chevron, the centreline of the aperture is offset 25 mm from the centreline of the face of the brick.

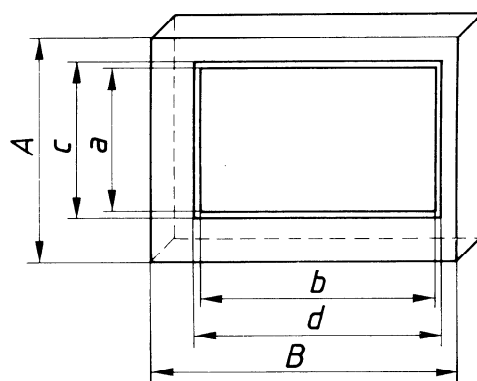

a) Cut

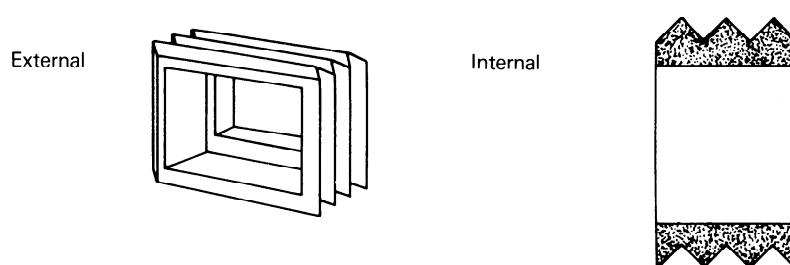

b) Category 1, without step

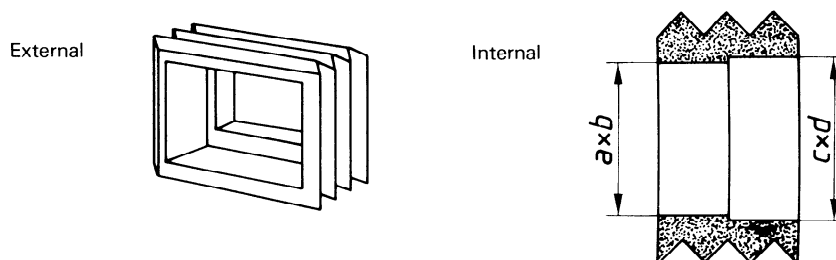

c) Category 1, with step ( $e = f$ )

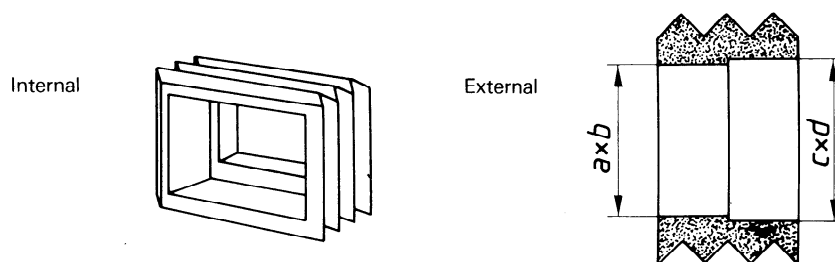

d) Category 2, with step and inner redan ( $e \neq f$ )

Figure 9 – Aperture bricks for square and rectangular windows

Table 10 — Category 1 aperture bricks for square and rectangular windows

Reference number	$A \times B$	Window mounting						Type and shape of window	Approximate mass kg
		$a$	$b$	$c$	$d$	$e$	$f$		
3V0 263	600 × 800	455	655	455	655	150	0 <sup>1)</sup>	Rectangular 400 × 600	145
3V0 264	800 × 1 000	655	855	655	855	150	0 <sup>1)</sup>	Rectangular 600 × 800	370
3V2 265	600 × 900	491	791	511	811	75	75	Rectangular 400 × 700	165 <sup>2)</sup>
3V2 266	550 × 650	421	511			75		Rectangular 330 × 420 external	155 <sup>2)</sup>
				441	531		75	330 × 420 internal	
3V2 267	800 × 1 000	691	891			75		Rectangular 500 × 700 external	200 <sup>2)</sup>
				711	911		75	600 × 800 internal	

1) No step.

2) These aperture bricks are made solely of steel.

NOTE — If, in special cases, an aperture brick is turned through 180° around the vertical axis of the aperture to change the direction of assembly, it should be noted that, taking into account the chevron, the centreline of the aperture is offset 25 mm from the centreline of the face of the brick.

Table 11 — Category 2 aperture bricks for square and rectangular windows<sup>1)</sup>

Reference number	$A \times B$	Window mounting						Type and shape of window	Approximate mass kg
		$a$	$b$	$c$	$d$	$e$	$f$		
3V1 268	650 × 850	455	655			100		Rectangular 400 × 600 external	305
				555	755		50	500 × 700 internal	
3V1 269	750 × 950	555	755			50		Rectangular 500 × 700 external	345
				655	855		100	600 × 800 internal	

1) Unlike category 1 aperture bricks, category 2 aperture bricks have an inner redan [see figure 9d) and the note to figure 11d)].

### 2.1.8 Windows

The minimum average density of the glass is  $5,2 \text{ g/cm}^3 \pm 0,02 \text{ g/cm}^3$ .

The minimum thickness of glass is 330 mm.

NOTE — The shielding value of the glass blocks fitted in these window assemblies is calculated using cobalt-60 as the radiation source.

In certain circumstances, and particularly at lower energies, this may result in windows not providing shielding equal to that of the lead wall for which they were designed. This case may require a special design.



2.1.8.1 Circular windows

See figure 10.

The dimensions of circular windows for 150 mm lead thickness are given in tables 12 and 13.

NOTE — Circular windows are demountable.

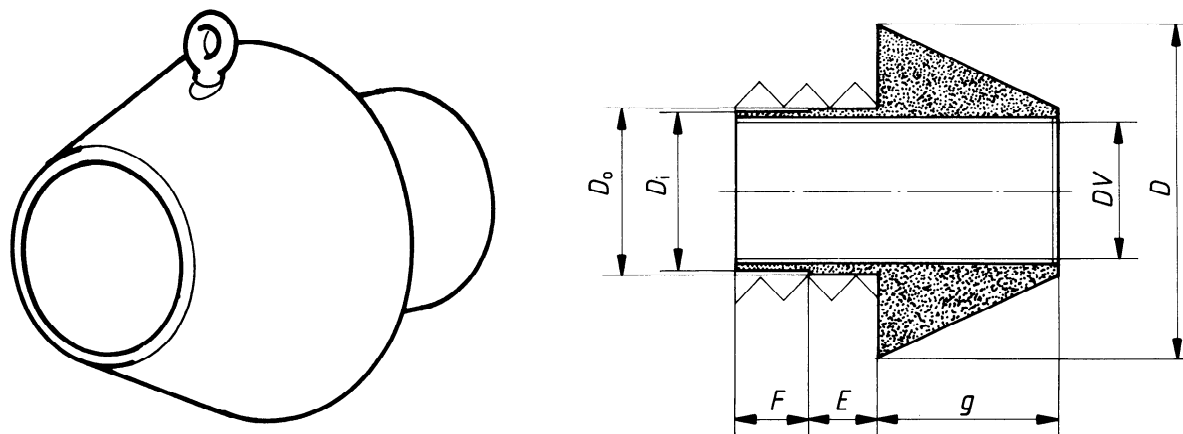

Figure 10 — Circular window

Table 12 — Category 1 circular windows

Aperture brick mm	Reference number	Window mounting <sup>1)</sup>				Flange		Glass		Approximate mass kg
		$D_i$	$D_o$	$E$	$F$	$D$	$g$	$D_V$	Density <sup>2)</sup> g/cm <sup>3</sup>	
200 × 200	3V0 300	170	172	72	76,25	389	188	140	5,2	120
300 × 300	3V0 302	266	270	70	76,5	421	188	230	5,2	195
400 × 400	3V0 304	366	370	70	76,5	521	188	330	5,2	310

1) The dimensions given here are the dimensions of the aperture brick; in practice they shall be reduced by the necessary clearance for installation.

2) The values correspond to measurements performed at 20 °C on commercially available units.

Table 13 — Category 2 circular windows

Aperture brick mm	Reference number	Window mounting <sup>1)</sup>				Flange		Glass		Approximate mass kg
		$D_i$	$D_o$	$E$	$F$	$D$	$g$	$D_V$	Density <sup>2)</sup> g/cm <sup>3</sup>	
200 × 200	3V0 307	150	160	75	75	320	210	130	5,2	110
300 × 300	3V0 311	240	250	75	75	410	210	220	5,2	210

1) The dimensions given here are the dimensions of the aperture brick; in practice they shall be reduced by the necessary clearance for installation.

2) The values correspond to measurements performed at 20 °C on commercially available units.

2.1.8.2 Square and rectangular windows

See figure 11.

The dimensions of square and rectangular windows for a lead thickness of 150 mm are given in tables 14 and 15.

NOTE — Square and rectangular windows for a lead thickness of 150 mm are fixed or demountable.

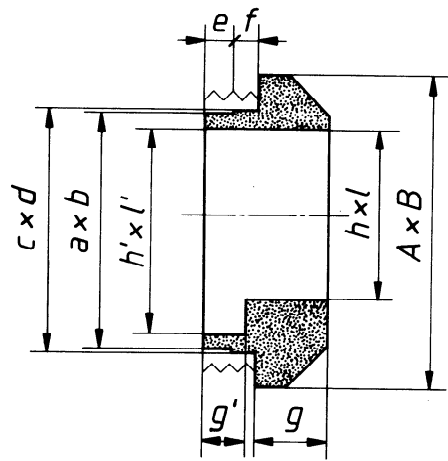

a) Cut

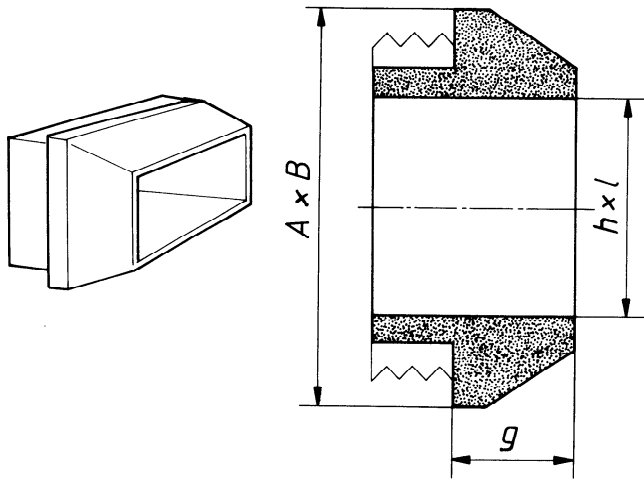

b) Category 1, without step

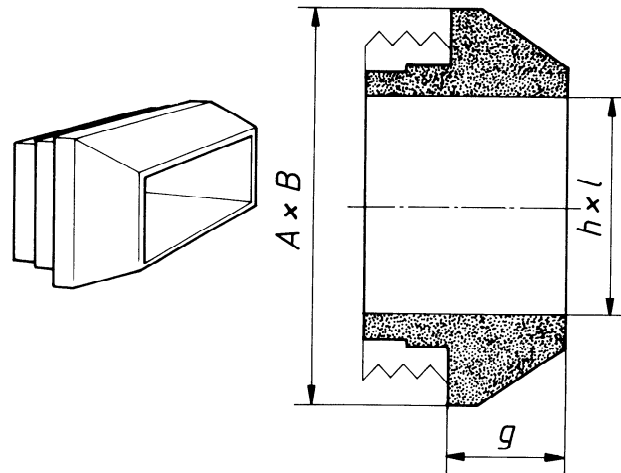

c) Category 1, with step

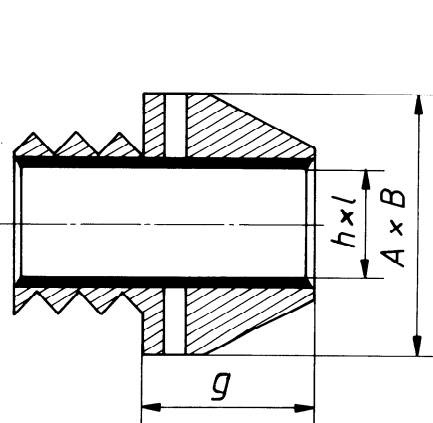

d) Category 2, fixed

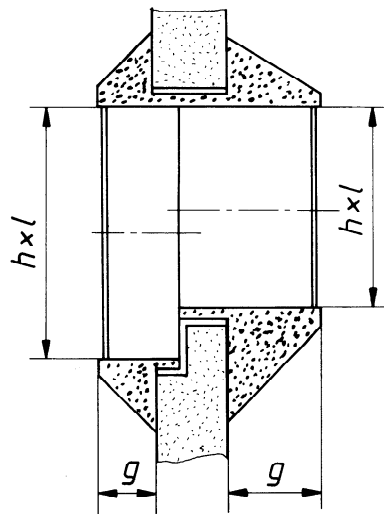

e) Category 2, combined windows

NOTE — These assemblies correspond to the combined use of two existing windows of 50 mm and 100 mm thickness. In this use, only the outer window is demountable, whereas the inner window is permanently fixed in the wall.

Figure 11 — Square and rectangular windows

Table 14 — Category 1 square and rectangular windows

Aperture brick mm	Reference number	Mounting <sup>1)</sup>							External frame							Glass				Approximate mass kg
		a	b	c	d	e	f	A	B	g	g'	h	h'	l	l'	Density <sup>2)</sup> g/cm <sup>3</sup>				
mm																				
200 × 300	3V2 352	—	—	—	—	150	— <sup>3)</sup>	325	425	210	—	145	145	245	245	5,2	260			
600 × 800	3V0 363 <sup>4)</sup>	Fixed					150	— <sup>3)</sup>	670	870	196	—	400	400	600	600	5,2	1 100		
		Demountable																		
800 × 1 000	3V0 364 <sup>5)</sup>	655	855	655	855	150	— <sup>3)</sup>	860	1 060	225	—	600	600	800	800	5,2	1 580			
600 × 900	3V0 365	Demountable					75	75	720	1 020	215	—	400	400	700	700	5,2	1 170 <sup>6)</sup>		
		Demountable																		
550 × 650	3V0 366	Demountable					75	75	670	770	215	—	330	330	420	420	5,2	760 <sup>6)</sup>		
		Demountable																		
800 × 1 000	3V0367	691	891	711	911	75	75	920	1 120	215	130	500	600	700	800	5,2	1 740 <sup>6)</sup>			

1) The dimensions given here are the dimensions of the aperture brick; in practice they shall be reduced by the necessary clearance for installation.

2) The values correspond to measurements performed at 20 °C on commercially available windows.

3) No step.

4) Combined system of rectangular windows 1V0 360 and 2V0 361.

5) Combined system of rectangular windows 1V0 360 and 2V0 362.

6) These windows housings are made solely of cast iron.

Table 15 — Category 2 square and rectangular windows

Aperture brick mm	Reference number	Mounting <sup>1)</sup>										External frame			Glass		Approximate mass kg
		a	b	c	d	e	f	A	B	g	h	l	Density <sup>2)</sup> g/cm <sup>3</sup>				
200 × 200	3V2 355	—	—	—	—	—	—	325	325	210	145	145	145	5,2	200		
300 × 300	3V2 356	—	—	Fixed	—	—	—	425	423	210	245	245	245	5,2	340		
300 × 400	3V2 357	—	—	Fixed	—	—	—	425	510	210	245	245	330	5,2	420		
400 × 500	3V2 358	—	—	Fixed	—	—	—	510	600	210	330	330	420	5,2	620		
650 × 850	3V0 359 <sup>3)</sup>	455	655	555	755	100	50	805	670	142	400	400	600 ext. 700 int.	5,2 5,2	1 250		
750 × 950	3V0 360 <sup>4)</sup>	555	755	655	855	50	100	770	970	120	500	500	700 ext. 800 int.	5,2 5,2	1 750		

1) The dimensions given here are the dimensions of the aperture brick; in practice they shall be reduced by the necessary clearance for installation.

2) The values correspond to measurements performed at 20°C on commercially available windows.

3) This assembly corresponds to the combined use of an existing window of 50 mm thickness (1V0 360) and an existing window of 100 mm thickness (2V0 361).

4) This assembly corresponds to the combined use of an existing window of 100 mm thickness (2V0 362) and an existing window of 50 mm thickness (1V0 360).

2.1.9 Sphere units

See figure 12.

The dimensions of sphere units for a lead thickness of 150 mm are given in tables 16 and 17.

NOTE – The flange is optional. It facilitates handling of the sphere unit, increases biological protection around the mounting and allows the sphere unit to be fixed in its aperture brick.

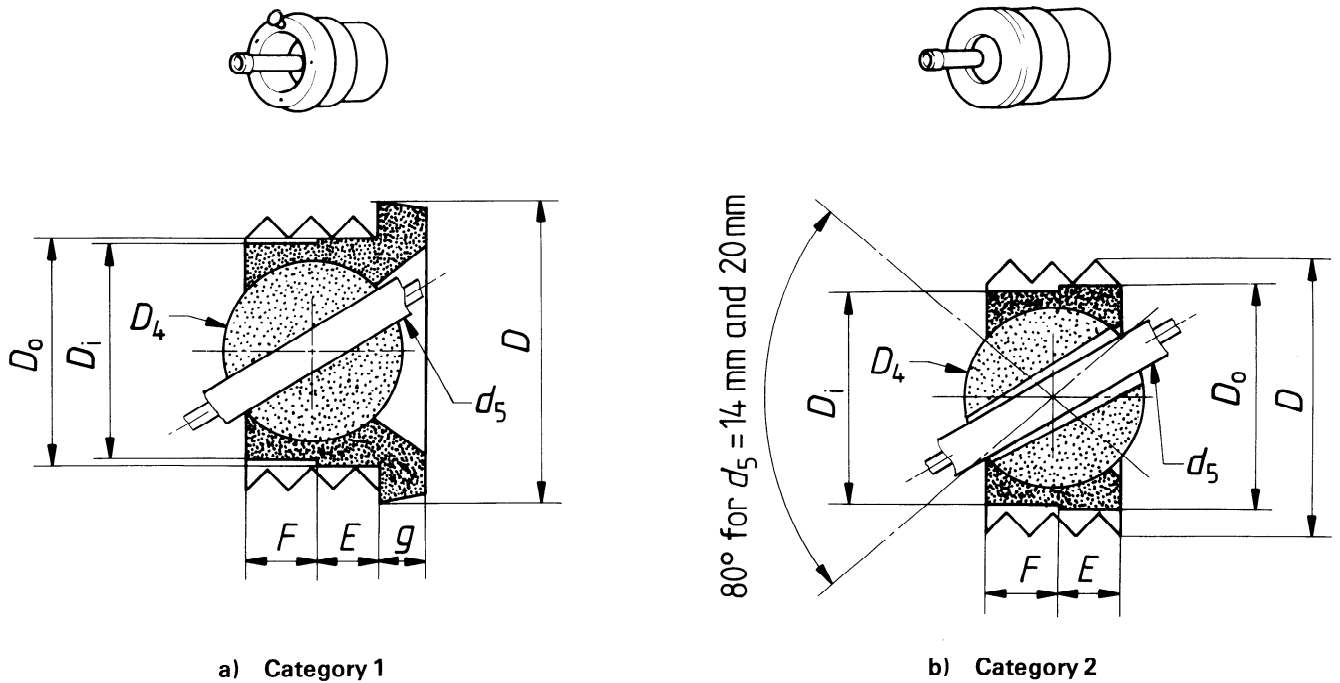

Figure 12 – Sphere units

Table 16 – Category 1 sphere units

Aperture brick mm	Reference number	Sphere unit mounting <sup>1)</sup>				Flange		Sphere unit		Approximate mass kg
		$D_i$	$D_o$	$E$	$F$	$D$	$g$	$D_4$	$d_5$ $\phi$ tong	
300 × 300	3V0 402	266	270	72	76,25	320	43	200	14 20 <sup>2)</sup> 33 <sup>3)</sup>	115

- 1) The dimensions given here are the dimensions of the aperture brick; in practice they shall be reduced by the necessary clearance for installation.
- 2) This passage of the tong is obtained by using a reducing unit which may be removed to obtain a diameter of 38 mm which allows the removal of an articulated tong.
- 3) A sphere unit for a 33 mm diameter tong can receive reducing units to accommodate 20 mm or 14 mm diameter tongs.

Table 17 – Category 2 sphere units

Aperture brick mm	Reference number	Sphere unit mounting <sup>1)</sup>				Flange		Sphere unit		Approximate mass kg
		$D_i$	$D_o$	$E$	$F$	$D$	$g$	$D_4$	$d_5$ $\phi$ tong	
300 × 300	3V0 411	240	250	75	75	270	– <sup>3)</sup>	215	14 20 <sup>2)</sup>	90

- 1) The dimensions given here are the dimensions of the aperture brick; in practice they shall be reduced by the necessary clearance for installation.
- 2) This passage of the tong is obtained by using a reducing unit which may be removed to obtain a diameter of 38 mm which allows the removal of an articulated tong.
- 3) Not standardized.

2.1.10 Plugs

See figure 13.

The dimensions of plugs for a lead thickness of 150 mm are given in tables 18 and 19.

NOTE — The flange is optional. It facilitates handling of the plug unit, increases biological protection around the mounting and allows the plug unit to be fixed in its aperture brick.

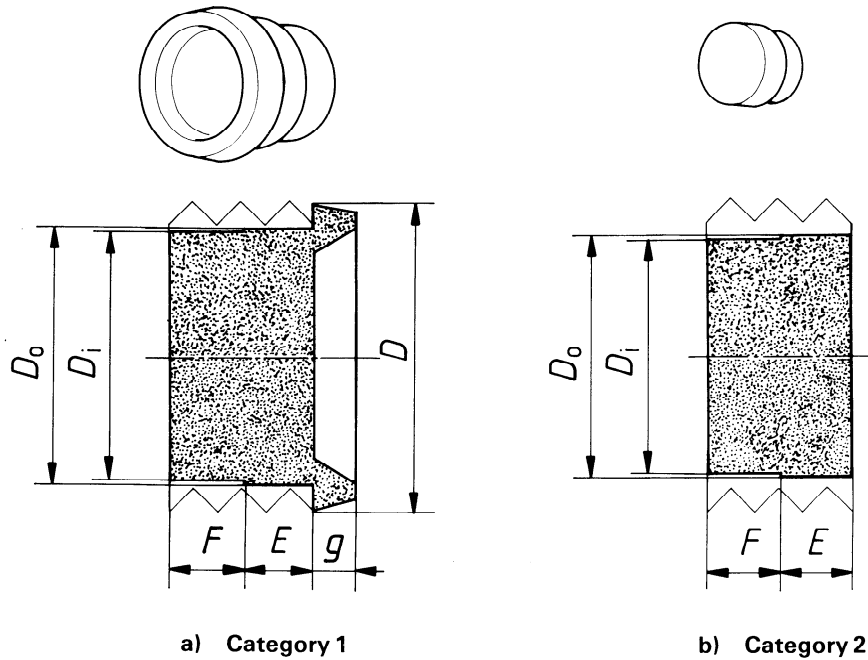

Figure 13 – Plugs

Table 18 – Category 1 plugs

Aperture brick mm	Reference number	Plug mounting <sup>1)</sup>				Flange		Approximate mass kg
		$D_i$	$D_o$	$E$	$F$	$D$	$g$	
mm								
200 × 200	3V0 500	170	172	72	76,25	220	34	45
300 × 300	3V0 502	266	270	70	76,5	320	43	110
400 × 400	3V0 504	366	370	70	76,5	430	60	215

1) The dimensions given here are the dimensions of the aperture brick; in practice they shall be reduced by the necessary clearance for installation.

Table 19 – Category 2 plugs

Aperture brick mm	Reference number	Plug mounting <sup>1)</sup>				Flange		Approximate mass kg
		$D_i$	$D_o$	$E$	$F$	$D$	$g$	
mm								
200 × 200	3V0 507	150	160	75	75	without flange		30
250 × 250	3V0 509	195	205	75	75	without flange		50
300 × 300	3V0 511	240	250	75	75	without flange		80

1) The dimensions given here are the dimensions of the aperture brick; in practice they shall be reduced by the necessary clearance for installation.

2.1.11 Reducing units

See figure 14.

The dimensions of reducing units for a lead thickness of 150 mm are given in tables 20 and 21.

NOTE — The flange is optional. It facilitates handling of the reducing unit, increases biological protection around the mounting and allows the reducing unit to be fixed in its aperture brick.

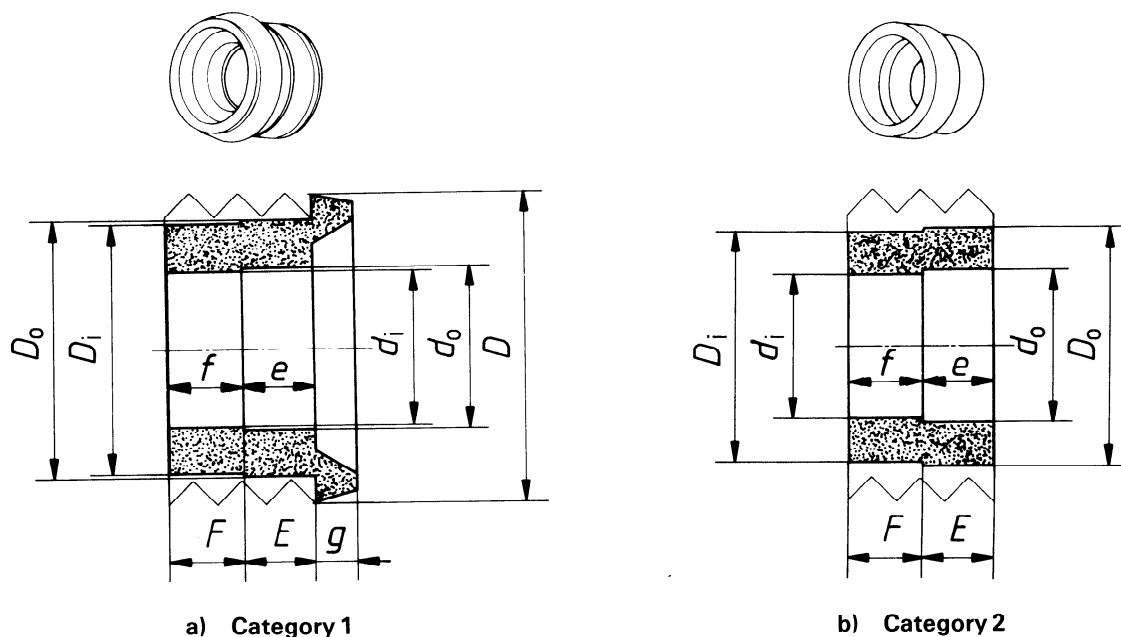

Figure 14 — Reducing units

Table 20 — Category 1 reducing units<sup>1)</sup>

Aperture brick mm	Reference number	External mounting <sup>2)</sup>				Internal mounting				Approximate mass kg
		$D_i$	$D_o$	$E$	$F$	$d_i$	$d_o$	$e$	$f$	
300 × 300	3V0 602	266	270	70 + flange	76,5	170	172	72	76,25	70
400 × 400	3V0 604	366	370	70 + flange	76,5	266	270	70	76,5	120

1) These reducing units have a flange (for the dimensions of the flange, see table 18).

2) The dimensions given here are the dimensions of the aperture brick; in practice they shall be reduced by the necessary clearance for installation.

Table 21 — Category 2 reducing units<sup>1)</sup>

Aperture brick mm	Reference number	External mounting <sup>2)</sup>				Internal mounting				Approximate mass kg
		$D_i$	$D_o$	$E$	$F$	$d_i$	$d_o$	$e$	$f$	
250 × 250	3V0 609	195	205	75	75	150	160	75	75	20
300 × 300	3V0 610	240	250	75	75	150	160	75	75	45
300 × 300	3V0 611	240	250	75	75	195	205	75	75	30
350 × 350	3V0 613	285	295	75	75	240	250	75	75	30

1) These reducing units have no flange.

2) The dimensions given here are the dimensions of the aperture brick; in practice they shall be reduced by the necessary clearance for installation.

### 2.1.12 Assembly of functional units

A general diagram of functional units for 150 mm lead thickness is given in figure 15 for units of category 1 and in figure 16 for units of category 2.

In each of the diagrams, units such as aperture bricks (circular, rectangular and square), windows, plugs, sphere units and reducing units have been illustrated.

NOTE — All units are represented in their usual assembly direction, but they can be reversed, except for

- in category 1 : 3V2 352
- in category 2 : 3V2 355  
3V2 356  
3V2 357  
3V2 358

which are fixed units.



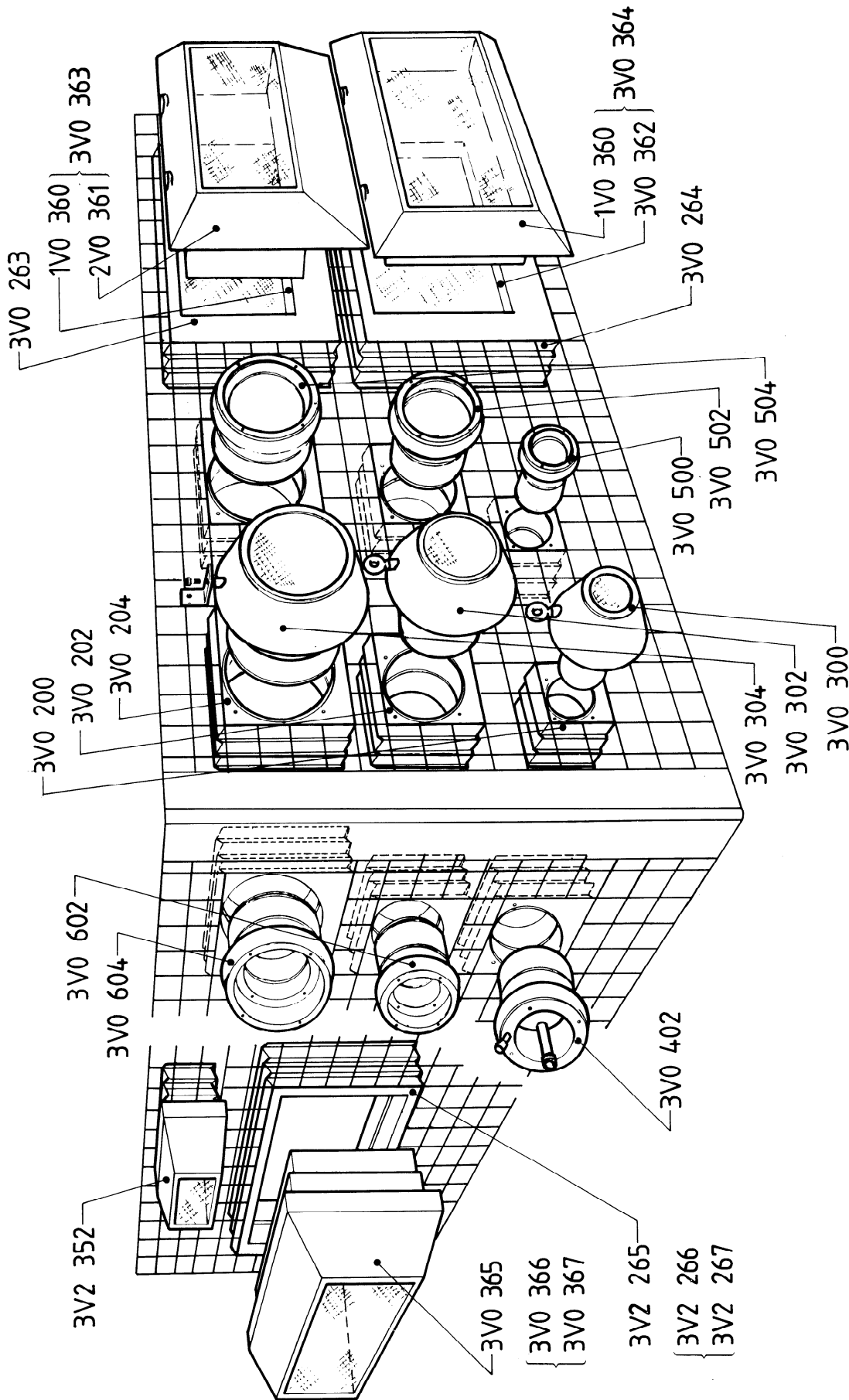

Figure 15 — General diagram of functional units for 150 mm lead thickness (category 1)

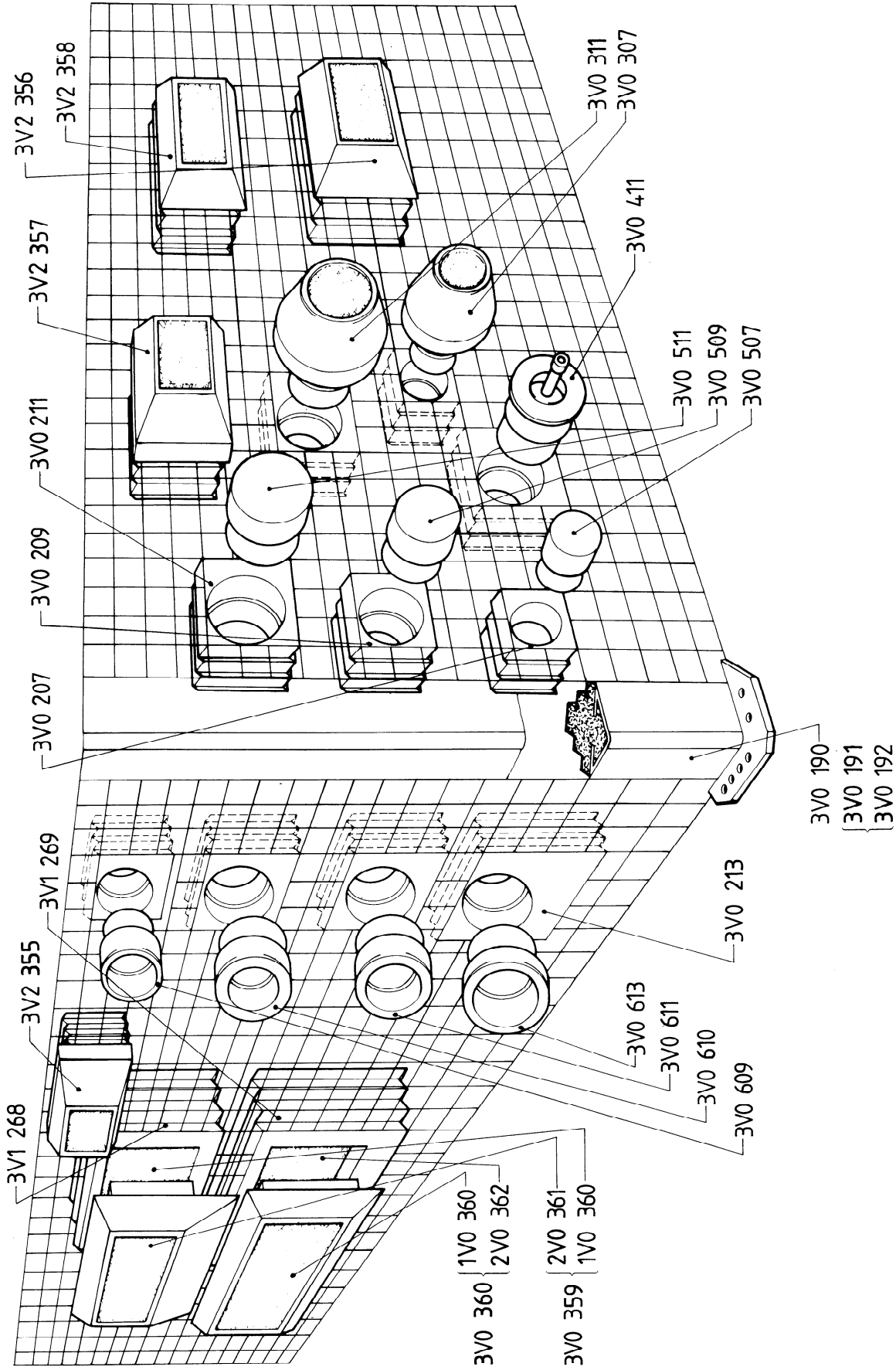

Figure 16 — General diagram of functional and corner units for 150 mm lead thickness (category 2)

## 2.2 Category 3

### 2.2.1 Plain bricks

Each type of plain brick can be assembled in the same way in each of the two assembly directions.

Table 22 shows the dimensions of category 3, three-chevron plain bricks.

**Table 22 — Category 3 plain bricks**

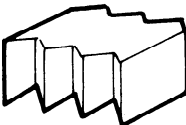
Type	Reference number	Dimensions mm		Diagram	Approximate mass kg
		<i>H</i>	<i>L</i>		
Base plain brick	3V0 110	15	100		4
Top plain brick	3V0 112	85	100		12

### 2.2.2 Corner bricks

The dimensions of category 3, three-chevron corner bricks are given in table 23.

**Table 23 — Category 3 corner bricks**

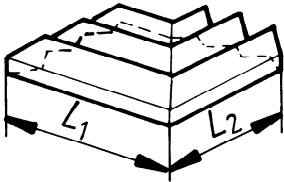
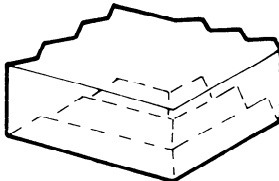
Type	Reference number	Dimensions mm			Diagram	Approximate mass kg
		<i>H</i>	<i>L</i> <sub>1</sub> Re-entrant chevron	<i>L</i> <sub>2</sub> Projecting chevron		
Base plain brick	3V1 140	15	200	150		9
Top corner brick	3V1 142	85	200	150		23

## Section 3 : Lead shielding units — Thickness 200 mm

### 3.1 Categories 1 and 2

#### 3.1.1 Basic units and assembly of walls for enclosures of 200 mm thickness

Basic units with four chevrons are not manufactured. Lead shielding walls of 200 mm thickness must therefore be constructed using a combination of one-, two- and three-chevron basic units. Examples of possible combinations are given in figures 17 and 18.

The specifications of one- and two-chevron basic units are given in ISO 7212, and of three-chevron basic units in 2.1.1 to 2.1.5 of this part of ISO 9404.

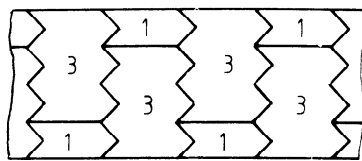

a) One- and three-chevron bricks

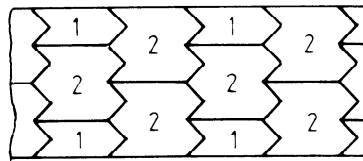

b) One- and two-chevron bricks

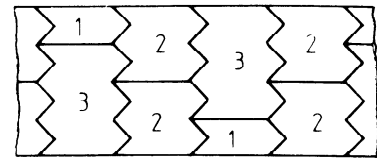

c) One-, two- and three-chevron bricks

Figure 17 — Examples of wall construction with plain bricks

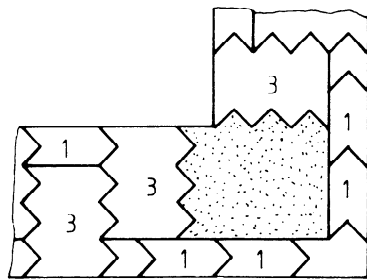

a) One- and three-chevron bricks

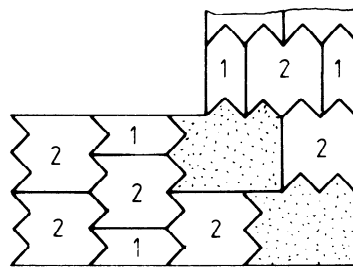

b) One- and two-chevron bricks

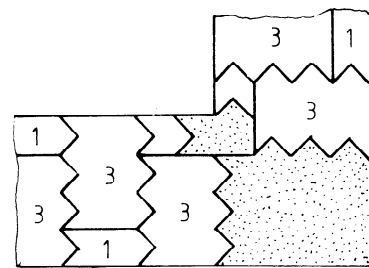

c) One- and three-chevron bricks

Figure 18 — Examples of corner construction with corner bricks and plain bricks

#### 3.1.2 Posts

Posts are used to provide a framework for brick enclosures.

When used, external tie-rods and rigid angle bars can be attached.

A corner post and two T-posts with four chevrons are standardized (see table 24). However, corners for 200 mm thick enclosures can also be constructed using a combination of one- and two-chevron posts, or two two-chevron posts. Some examples of possible combinations are given in figures 19 and 20.

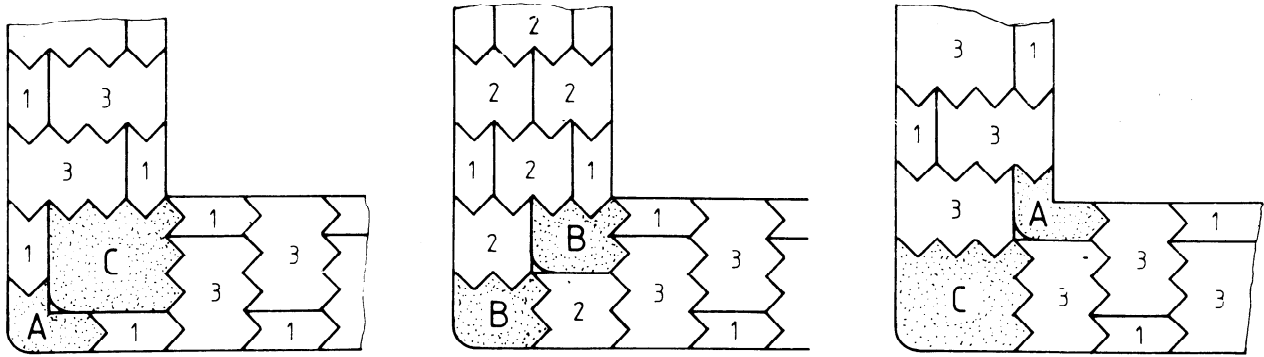

**Key**

- A One-chevron corner posts
- B Two-chevron corner posts
- C Three-chevron corner posts

**Figure 19 – Examples of corner construction using posts**

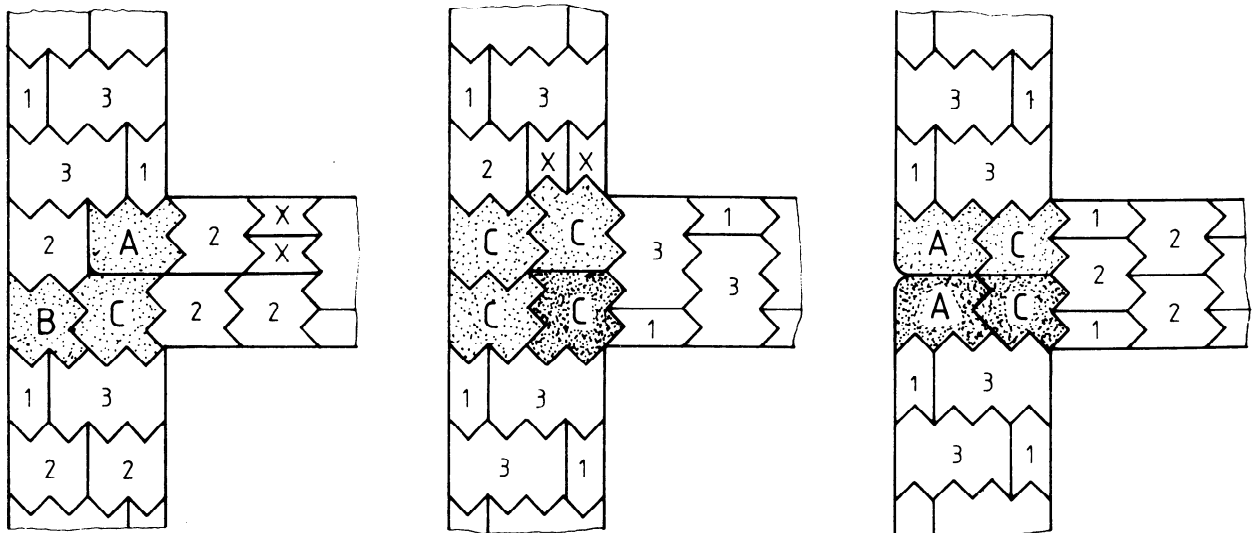

**Key**

- A One-chevron corner posts
- B Two-chevron T-posts, 1M2F (1 male, 2 female)
- C Three-chevron T-posts, 2M1F (2 male, 1 female)

NOTE – The darkened posts are reversed on assembly.

**Figure 20 – Examples of intersecting wall construction with T-posts and corner posts**

Table 24 – Category 2 posts (assembly direction 1)<sup>1)</sup>

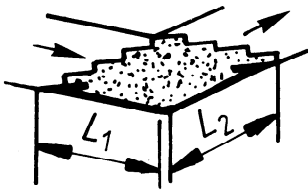
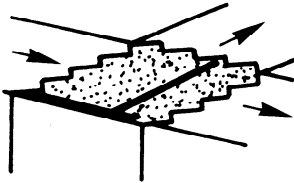
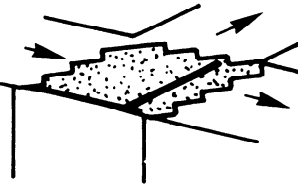
Type	Reference number	Dimensions mm		Diagram	Approximate mass kg
		$L_1$ Re-entrant chevron	$L_2$ Projecting chevron		
Corner posts	4V0 190	200	200		440
T-posts (2M1F)	4V0 191	200	200		465
T-posts (1M2F)	4V0 192	200	200		410

1) By turning these posts upside down, assembly direction 2 is obtained.

### 3.1.3 Aperture bricks

Externally, four-chevron aperture bricks are square or rectangular and their internal dimensions are standardized so that the units they hold may be interchangeable (see figures 21 and 22).

The dimensions of aperture bricks for a lead thickness of 200 mm are given in tables 25, 26, 27 and 28.

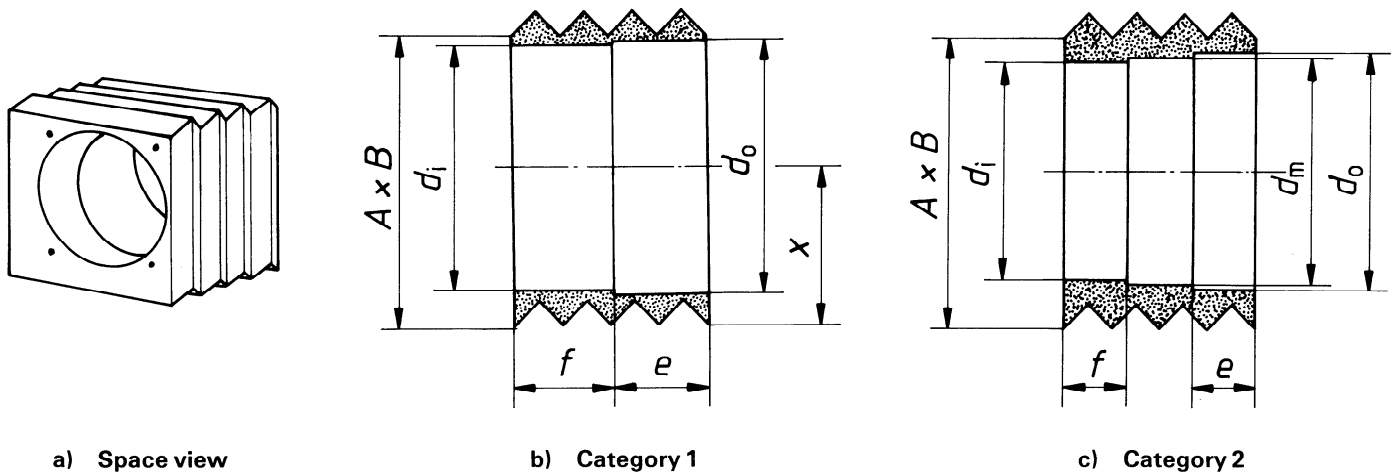
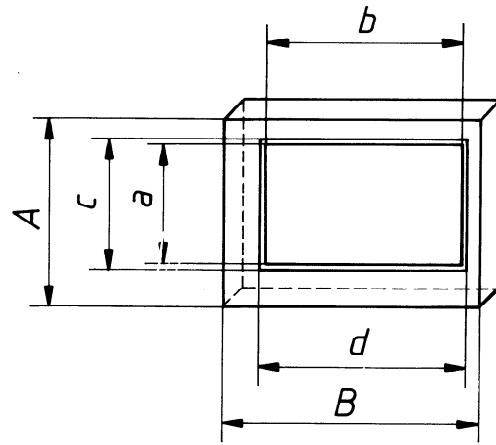
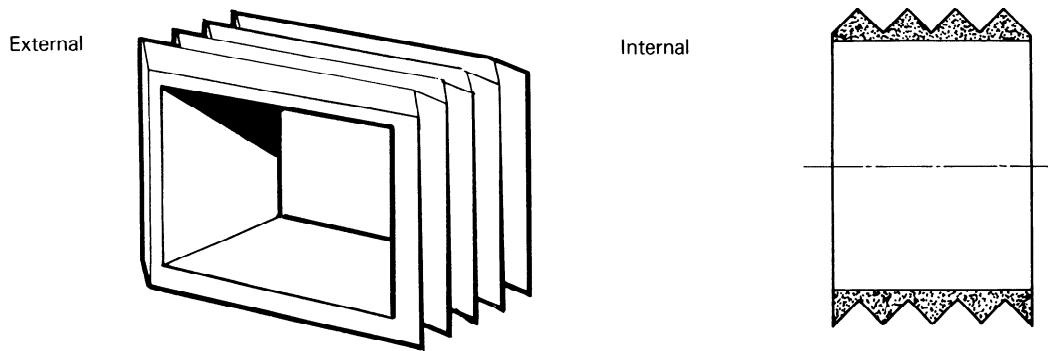

Figure 21 – Aperture bricks for circular units



a) Cut



b) Category 1, without step

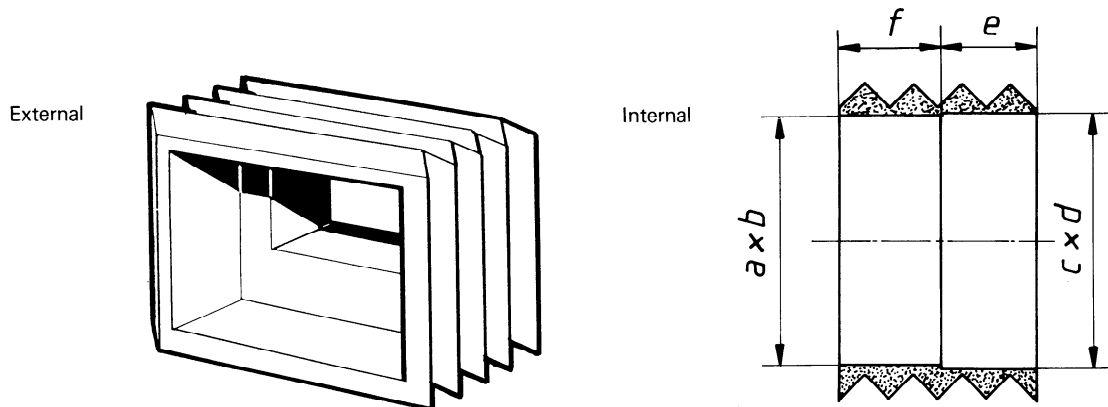

c) Category 1, with step ( $e = f$ )

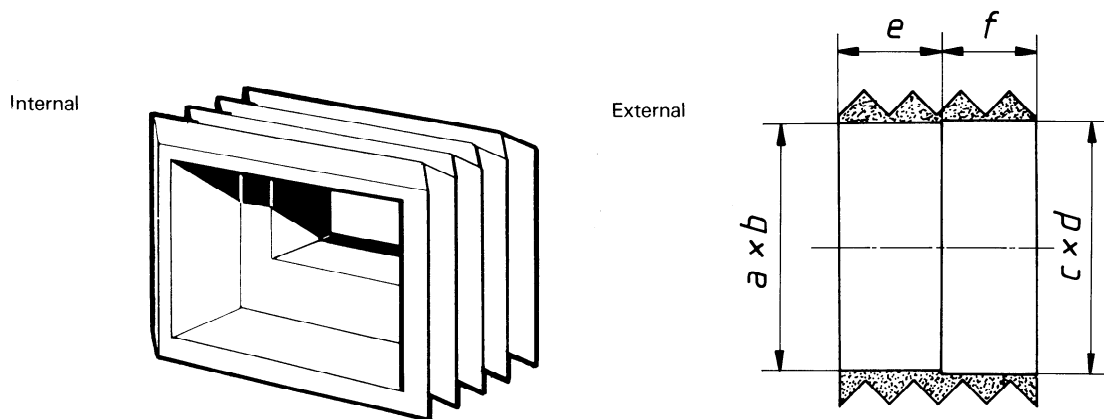

d) Category 2, with step and inner redan ( $e \neq f$ )

Figure 22 – Aperture bricks for square and rectangular windows

**Table 25 – Category 1 aperture bricks for circular units**

Reference number	A × B	x	d <sub>i</sub>	d <sub>m</sub>	d <sub>o</sub>	e	f	Approximate mass kg
4V0 200	200 × 200	112,5	170	—	172	97	101	40
4V0 202	300 × 300	162,5	266	—	270	95	101	70
4V0 204	400 × 400	212,5	366	—	370	95	101	120

NOTE — If, in special cases, an aperture brick is turned through 180° around the vertical axis of the aperture to change the direction of assembly, it should be noted that, taking into account the chevron, the centreline of the aperture is offset 25 mm from the centreline of the face of the brick.

**Table 26 – Category 2 aperture bricks for circular units**

Reference number	A × B	x	d <sub>i</sub>	d <sub>m</sub>	d <sub>o</sub>	e	f	Approximate mass kg
4V0 206	150 × 150	87,5	100	107	114	65	65	30
4V0 207	200 × 200	112,5	140	150	160	65	65	50
4V0 209	250 × 250	137,5	185	195	205	65	65	70
4V0 211	300 × 300	162,5	230	240	250	65	65	100
4V0 213	350 × 350	187,5	275	285	295	65	65	130
4V0 215	400 × 400	212,5	320	330	340	65	65	160
4V0 217	450 × 450	237,5	365	375	385	65	65	190

NOTE — If, in special cases, an aperture brick is turned through 180° around the vertical axis of the aperture to change the direction of assembly, it should be noted that, taking into account the chevron, the centreline of the aperture is offset 25 mm from the centreline of the face of the brick.

**Table 27 – Category 1 aperture bricks for square and rectangular windows**

Reference number	A × B	Window mounting						Type and shape of window	Approximate mass kg
		a	b	c	d	e	f		
4V0 263	600 × 800	455	655	455	655	200	— 1)	Rectangular 400 × 600	195
4V0 264	800 × 1 000	655	855	655	855	200	— 1)	Rectangular 600 × 800	255
4V0 265	600 × 900	491	791	511	811	100	100	Rectangular 400 × 700	220 <sup>2)</sup>
4V2 266	550 × 650	421	511	—	—	100	—	330 × 420 external	205 <sup>2)</sup>
		—	—	441	531	—	100	330 × 420 internal	
4V2 267	800 × 1 000	691	891	—	—	100	—	525 × 680 external or 600 × 800 external	270 <sup>2)</sup>
		—	—	711	911	—	100	600 × 800 internal	

1) No step.

2) These aperture bricks are made solely of steel.

NOTE — If, in special cases, an aperture brick is turned through 180° around the vertical axis of the aperture to change the direction of assembly, it should be noted that, taking into account the chevron, the centreline of the aperture is offset 25 mm from the centreline of the face of the brick.



Table 28 — Category 2 aperture bricks for square and rectangular windows<sup>1)</sup>

Reference number	$A \times B$	Window mounting						Type and shape of window	Approximate mass kg
		$a$	$b$	$c$	$d$	$e$	$f$		
4V1 268	750 × 950	455	655	—	—	100	—	Rectangular 400 × 600 external	600
		—	—	655	855	—	100	Rectangular 600 × 900 internal	
4V1 269	750 × 950	655	855	—	—	100	—	Rectangular 600 × 800 external	340
		—	—	655	855	—	100	Rectangular 600 × 800 internal	

1) Unlike category 1 aperture bricks, category 2 aperture bricks have an inner redan (see figure 22d) and the note to figure 24).

### 3.1.4 Windows

The minimum average density of the glass at 20 °C is  $4,2 \text{ g/cm}^3 \pm 0,02 \text{ g/cm}^3$  at the internal side (stabilized glass) and  $5,2 \text{ g/cm}^3 \pm 0,02 \text{ g/cm}^3$  at the external side.

Because of the instantaneous dose rate which can be reached, in enclosures with 200 mm thickness walls, the first slab of glass of the internal side of the window shall be stabilized.

The minimum thickness of glass for category 1 and 2 windows is 165 mm for stabilized glass and 345 mm for glass of density  $5,2 \text{ g/cm}^3 \pm 0,02 \text{ g/cm}^3$ .

NOTE — The shielding value of the glass blocks fitted in these window assemblies is calculated using cobalt-60 as the radiation source.

In certain circumstances, and particularly at lower energies, this may result in windows not providing shielding equal to that of the lead wall for which they were designed. This case may require a special design.

#### 3.1.4.1 Circular windows

See figure 23.

The nominal dimensions of circular windows for a 200 mm lead thickness are given in tables 29 and 30.

NOTE — Circular windows are demountable.

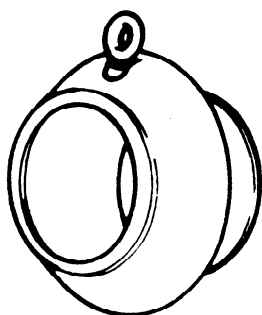

a) Space view

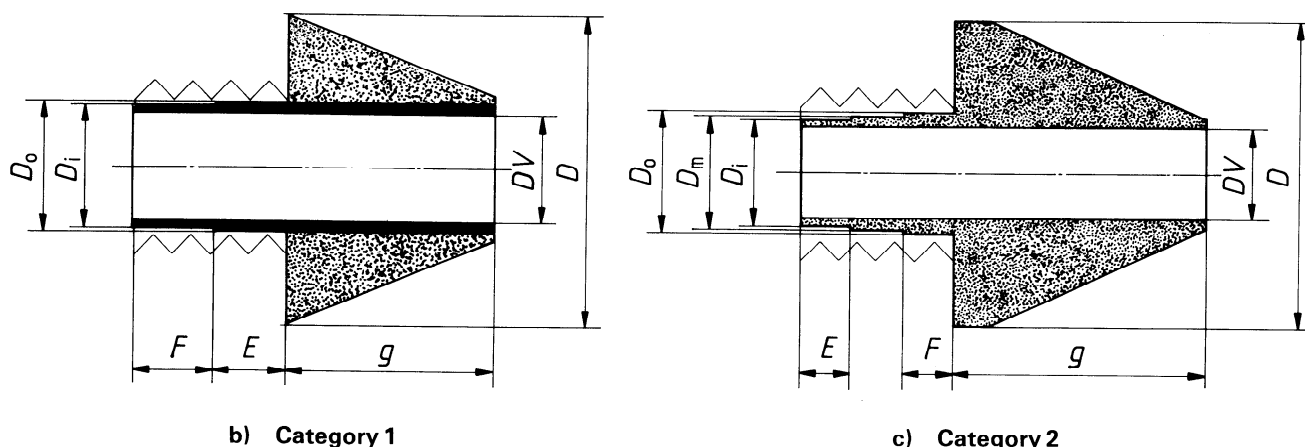

b) Category 1

c) Category 2

Figure 23 — Circular windows

Table 29 — Category 1 circular windows

Aperture brick mm	Reference number	Window mounting <sup>1)</sup>					Flange		Glass		Approximate mass	
		$D_i$	$D_m$	$D_o$	$E$	$F$	$D$	$g$	$DV$	Density <sup>2)</sup>		
mm											g/cm <sup>3</sup>	kg
200 × 200	4V0 300	170	—	172	97	101,25	404	270	140	4,2 and 5,2	215	
300 × 300	4V0 302	266	—	270	95	101,5	486	270	230	4,2 and 5,2	320	
400 × 400	4V0 304	366	—	370	95	101,5	560	270	330	4,2 and 5,2	470	

1) The dimensions given here are the dimensions of the aperture brick; in practice they shall be reduced by the necessary clearance for installation.

2) The values correspond to measurements performed at 20 °C on commercially available windows.

Table 30 — Category 2 circular windows

Aperture brick mm	Reference number	Window mounting <sup>1)</sup>					Flange		Glass		Approximate mass	
		$D_i$	$D_m$	$D_o$	$E$	$F$	$D$	$g$	$DV$	Density <sup>2)</sup>		
mm											g/cm <sup>3</sup>	kg
200 × 200	4V0 307	140	150	160	63	67	400	336	120	4,2 and 5,2	250	
300 × 300	4V0 311	230	240	250	63	67	490	335	210	4,2 and 5,2	400	

1) The dimensions given here are the dimensions of the aperture brick; in practice they shall be reduced by the necessary clearance for installation.

2) The values correspond to measurements performed at 20 °C on commercially available windows.

### 3.1.4.2 Square and rectangular windows

See figure 24.

The square and rectangular windows for a lead thickness of 200 mm are fixed or demountable.

The dimensions of square and rectangular windows for a 200 mm lead thickness are given in tables 31 and 32.

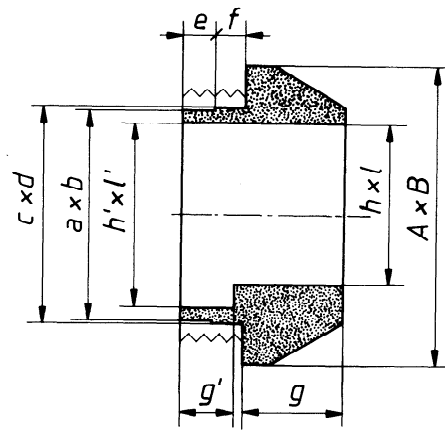

a) Cut

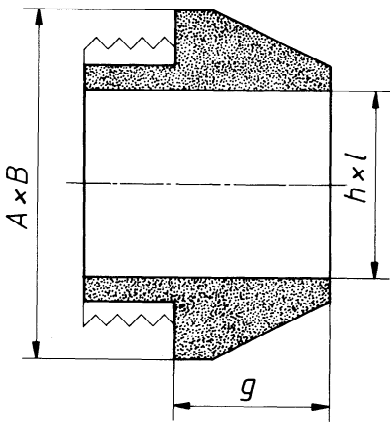
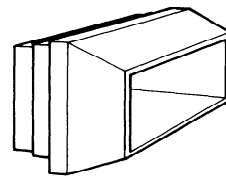
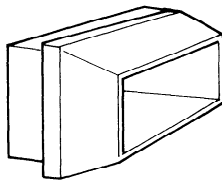

b) Category 1, without step

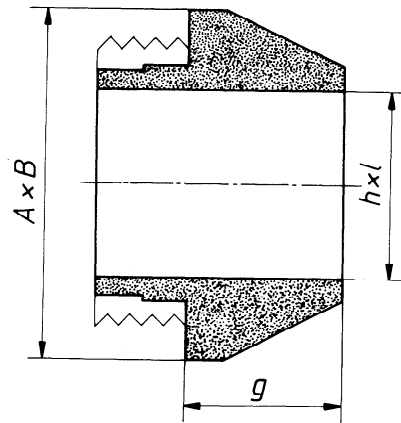

c) Category 2, with step

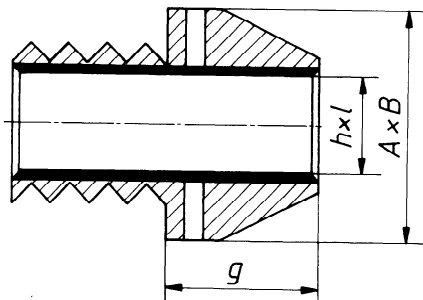

d) Category 2, fixed

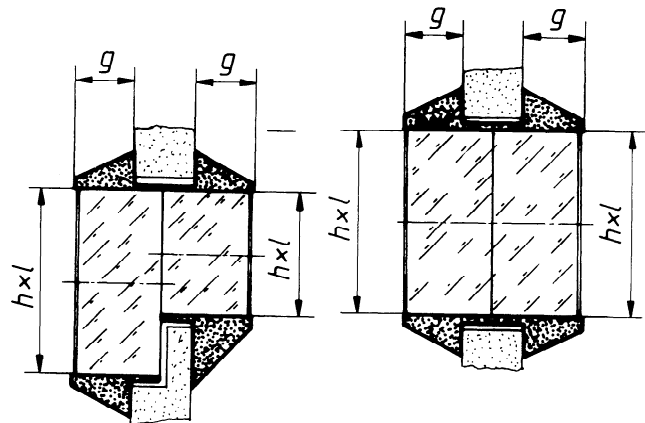

e) Category 2, combined windows<sup>1)</sup>

1) These assemblies correspond to the combined use of two existing windows of 100 mm thickness. In this use, only the outer window is demountable, whereas the inner window is permanently fixed in the wall.

Figure 24 – Square and rectangular windows

Table 31 — Category 1 square and rectangular windows

Aperture brick mm	Reference number	Mounting <sup>1)</sup>							External frame					Glass				Approximate mass kg
		a	b	c	d	e	f	A	B	g	g'	h	h'	l	l'	Density <sup>2)</sup> g/cm <sup>3</sup>		
mm																		
200 × 300	4V2 352	—	—	—	—	—	—	425	525	325	—	145	145	245	245	4,2 and 5,2	550	
600 × 800	4V0 363 <sup>3)</sup>	Fixed							670	870	196	—	400	400	600	600	4,2 and 5,2	1 670
		455	655	455	655	—	—	—										
800 × 1 000	4V0 364 <sup>4)</sup>	Demountable							860	1 060	225	—	600	600	800	800	4,2 and 5,2	2 600
		655	855	655	855	—	—	—										
600 × 900 <sup>5)</sup>	4V0 365	Demountable							750	1 050	330	—	400	400	700	700	4,2 and 5,2	1 800
		491	791	511	811	100	100	100										
550 × 650 <sup>5)</sup>	4V0 366	Demountable							730	830	330	—	330	330	420	420	4,2 and 5,2	1 070
		421	511	441	531	100	100	100										
800 × 1 000 <sup>5)</sup>	4V0367	691	891	711	911	100	100	980	1 180	330	165	525	600	680	680	4,2 and 5,2	2 600	

1) The dimensions given here are the dimensions of the aperture brick; in practice shall be reduced by the necessary clearance for installation.

2) The values correspond to measurements performed at 20 °C on commercially available windows.

3) Combined system of rectangular windows 2V0 361 and 2V0 362.

4) Combined system of rectangular windows 2V0 362 and 2V0 362.

5) These aperture bricks have cast iron housings.

Table 32 — Category 2 square and rectangular windows

Aperture brick mm	Reference number	Mounting <sup>1)</sup>							External frame				Glass			Approximate mass kg
		a	b	c	d	e	f	f	A	B	g	h	l	Density <sup>2)</sup> g/cm <sup>3</sup>		
200 × 200	4V2 355	—	—	—	—	—	—	—	425	425	325	145	145	4,2 and 5,2	440	
300 × 300	4V2 356	—	—	Fixed	—	—	—	—	525	525	325	245	245	4,2 and 5,2	690	
300 × 400	4V2 357	—	—	Fixed	—	—	—	—	525	610	325	245	245	4,2 and 5,2	840	
400 × 500	4V2 358	—	—	Fixed	—	—	—	—	610	700	325	330	330	4,2 and 5,2	1 140	
750 × 950	4V0 359 <sup>3)</sup>	455	655	655	855	100	100	100	805	870	142	400	600 ext.	4,2 and 5,2	1 900	
750 × 950	4V0 360 <sup>4)</sup>	655	855	655	855	100	100	100	865	1 065	200	600	800 int.	4,2 and 5,2	2 400 <sup>5)</sup>	

1) The dimensions given here are the dimensions of the aperture brick; in practice they shall be reduced by the necessary clearance for installation.  
 2) The values correspond to measurements performed at 20 °C on commercially available windows.  
 3) This assembly corresponds to the combined use of an existing window of 100 mm thickness (2V0 361) and a window which is of the same type as an existing window (2V0 362), with a density of 4,2 g/cm<sup>3</sup>.  
 4) This assembly corresponds to the combined use of an existing window of 100 mm thickness (2V0 362) and of the same window but with a density of 4,2 g/cm<sup>3</sup>.  
 5) Exceptional arrangement.

3.1.5 Sphere units

See figure 25.

The dimensions of sphere units for a lead thickness of 200 mm are given in tables 33 and 34.

NOTE — The flange is optional. It facilitates handling of the sphere unit, increases biological protection around the mounting and allows the sphere unit to be fixed in its aperture brick.

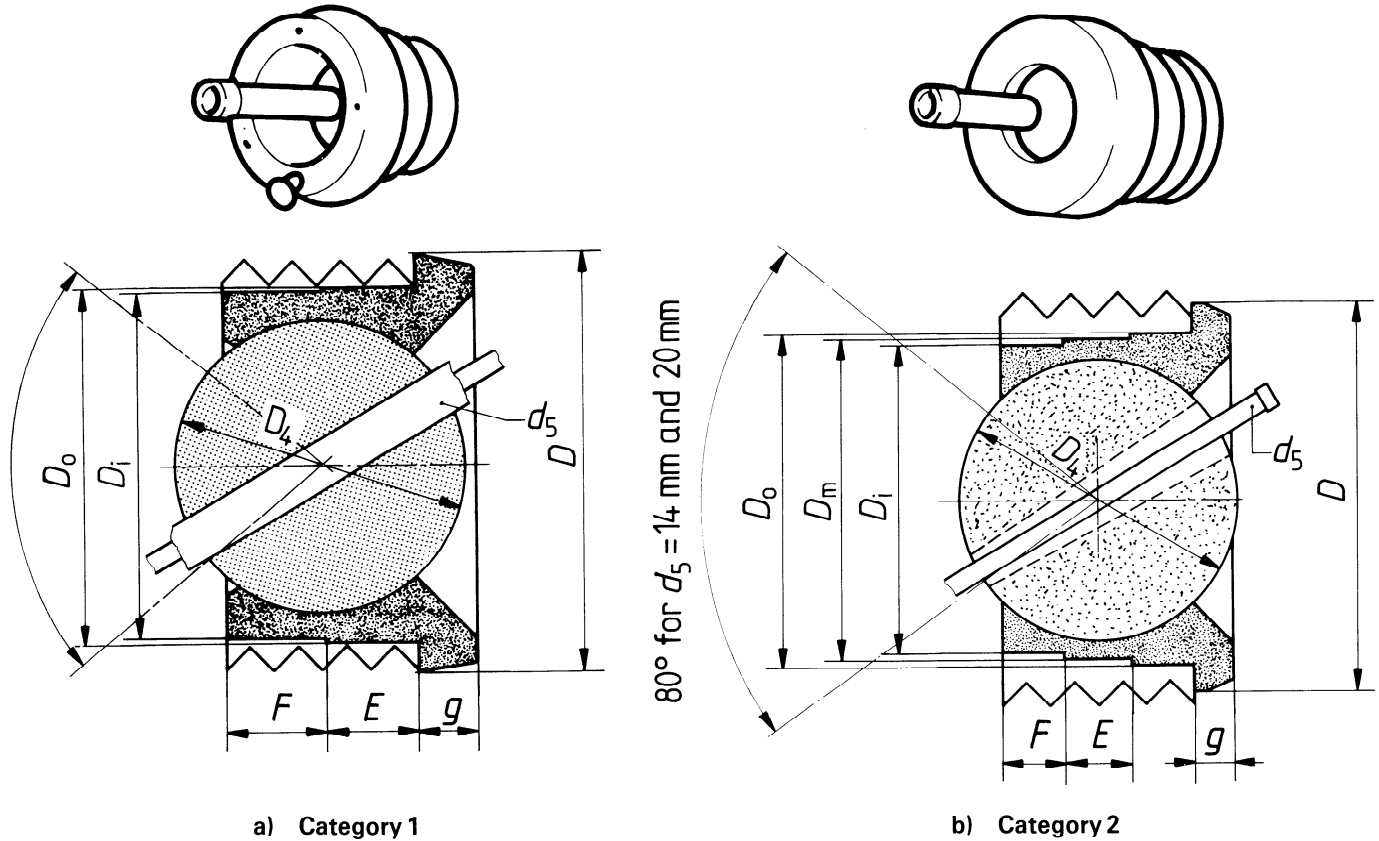

Figure 25 – Sphere units

Table 33 – Category 1 sphere units

Aperture brick mm	Reference number	Sphere unit mounting <sup>1)</sup>					Flange		Sphere unit		Approximate mass kg
		$D_i$	$D_m$	$D_o$	$E$	$F$	$D$	$g$	$D_4$	$d_5$ $\phi$ tong	
400 × 400	4V0 404	366	—	370	101,5	95	430	60	300	14 20 <sup>2)</sup> 33 <sup>3)</sup>	300

- 1) The dimensions given here are the dimensions of the aperture brick; in practice they shall be reduced by the necessary clearance for installation.
- 2) This passage of the tong is obtained by using a reducing unit which may be removed to obtain a diameter of 38 mm which allows the removal of an articulated tong.
- 3) A sphere unit for a 33 mm diameter tong can receive reducing units to accommodate 20 mm or 14 mm diameter tongs.

Table 34 — Category 2 sphere units

Aperture brick mm	Reference number	Sphere unit mounting <sup>1)</sup>					Flange		Sphere unit		Approximate mass kg
		$D_i$	$D_m$	$D_o$	$E$	$F$	$D$	$g$	$D_4$	$d_5$ $\phi$ tong	
400 × 400	4V0 415	320	330	340	63	67	400	— <sup>2)</sup>	290	14 20 <sup>3)</sup>	240

1) The dimensions given here are the dimensions of the aperture brick; in practice they shall be reduced by the necessary clearance for installation.  
 2) Not standardized.  
 3) This passage of the tong is obtained by using a reducing unit which may be removed to obtain a diameter of 38 mm which allows the removal of an articulated tong.

3.1.6 Plugs

See figure 26.

The dimensions of plugs for a lead thickness of 200 mm are given in tables 35 and 36.

NOTE — The flange is optional. It facilitates handling of the plug, increases biological protection around the mounting and allows the plug unit to be fixed in its aperture brick.

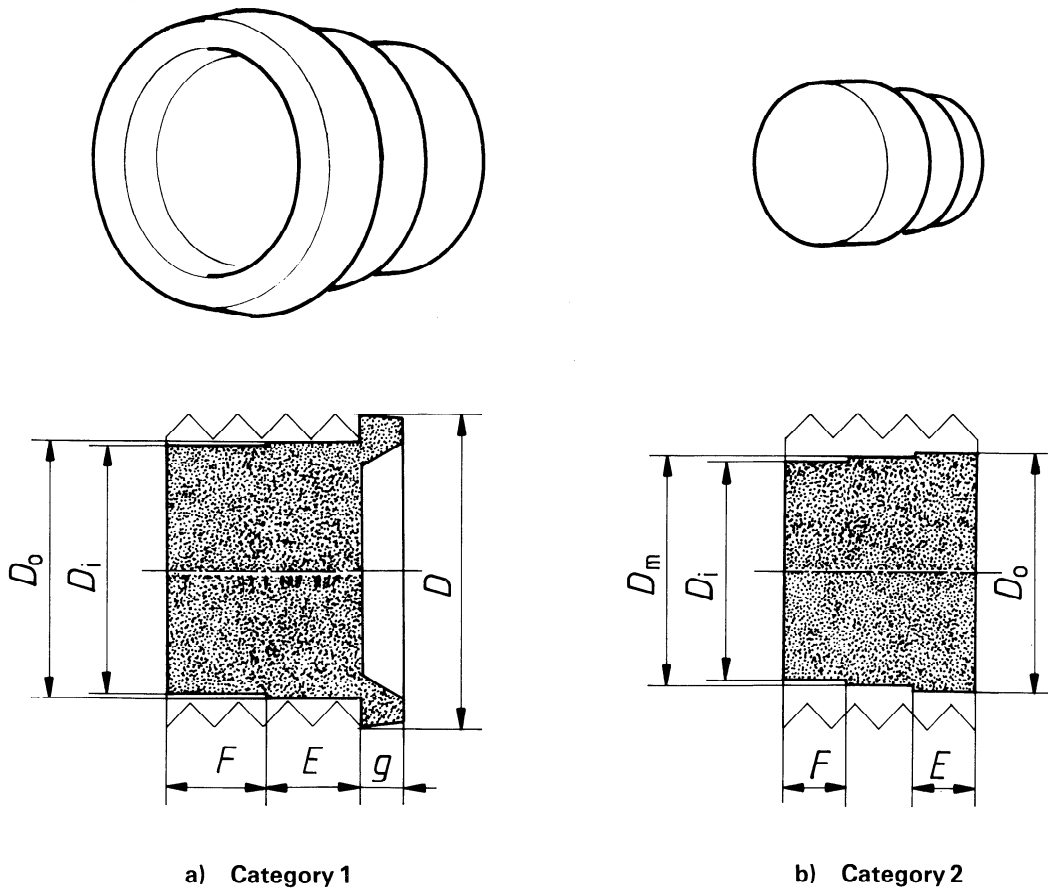

Figure 26 — Plugs

**Table 35 – Category 1 plugs**

Aperture brick mm	Reference number	Plug mounting <sup>1)</sup>					Flange		Approximate mass kg
		$D_i$	$D_m$	$D_o$	$E$	$F$	$D$	$g$	
200 × 200	4V0 500	170	—	172	97	101	220	34	60
300 × 300	4V0 502	266	—	270	95	101	320	43	140
400 × 400	4V0 504	366	—	370	97	101	430	60	275

1) The dimensions given here are the dimensions of the aperture brick; in practice they shall be reduced by the necessary clearance for installation.

**Table 36 – Category 2 plugs**

Aperture brick mm	Reference number	Plug mounting <sup>1)</sup>					Flange		Approximate mass kg
		$D_i$	$D_m$	$D_o$	$E$	$F$	$D$	$g$	
150 × 150	4V0 506	100	107	114	65	67	without flange		20
200 × 200	4V0 507	140	150	160	65	67	without flange		40
250 × 250	4V0 509	185	195	205	65	67	without flange		65
300 × 300	4V0 511	230	240	250	65	67	without flange		100
350 × 350	4V0 513	275	285	299	65	67	without flange		140
400 × 400	4V0 515	320	330	340	65	67	without flange		180

1) The dimensions given here are the dimensions of the aperture brick; in practice they shall be reduced by the necessary clearance for installation.

### 3.1.7 Reducing units

See figure 27.

The dimensions of reducing units for a lead thickness of 200 mm are given in tables 37 and 38.

NOTE — The flange is optional. It facilitates handling of the reducing unit, increases biological protection around the mounting and allows the reducing unit to be fixed in its aperture brick.



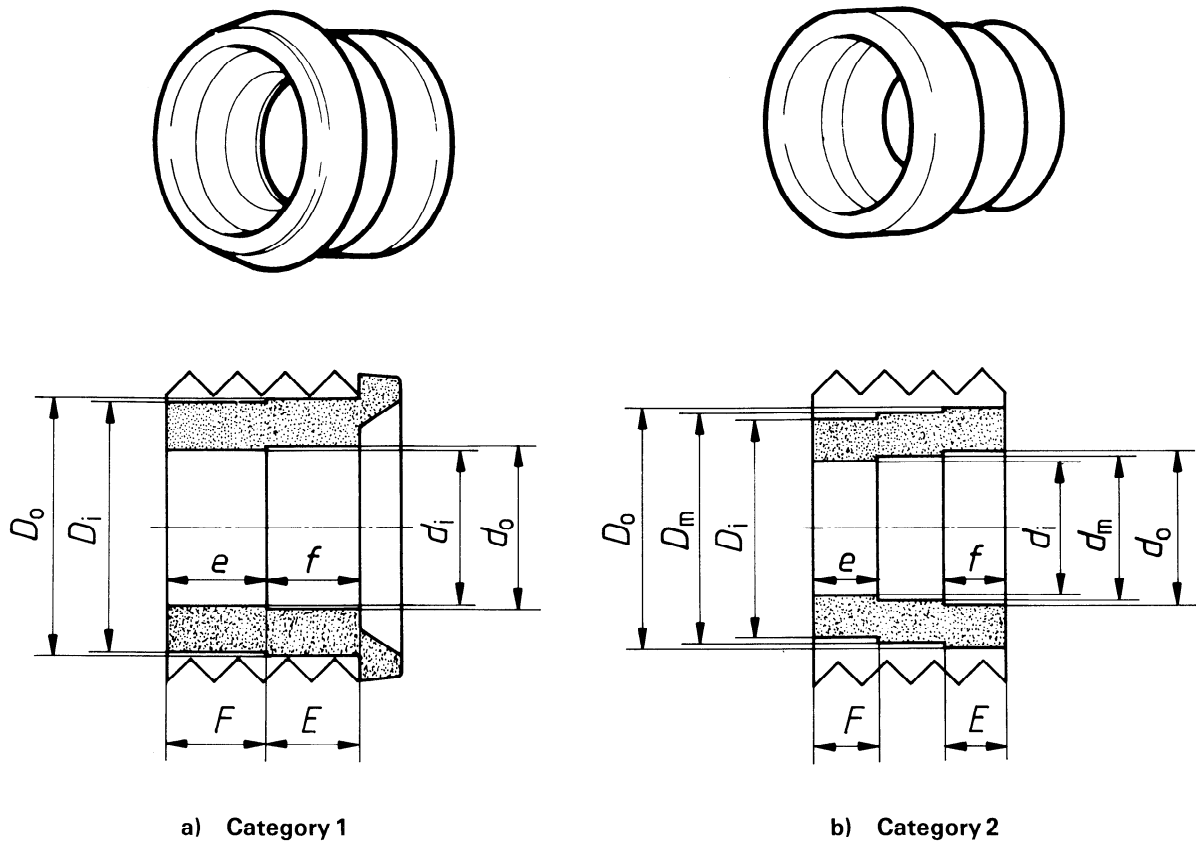

Figure 27 – Reducing units

Table 37 – Category 1 reducing units<sup>1)</sup>

Aperture brick mm	Reference number	External mounting <sup>2)</sup>					Internal mounting					Approximate mass kg
		$D_i$	$D_m$	$D_o$	$E$	$F$	$d_i$	$d_m$	$d_o$	$e$	$f$	
300 × 300	4V0 602	266	—	270	95 + flange	101	170	—	172	101	97	85
400 × 400	4V0 604	366	—	370	95 + flange	101	266	—	270	101	95	135

1) These reducing units have a flange (for the dimensions of the flanges, see table 35).

2) The dimensions given here are the dimensions of the aperture brick; in practice they shall be reduced by the necessary clearance for installation.

Table 38 — Category 2 reducing units<sup>1)</sup>

Aperture brick mm	Reference number	External mounting <sup>2)</sup>					Internal mounting					Approximate mass kg
		$D_i$	$D_m$	$D_o$	$E$	$F$	$d_i$	$d_m$	$d_o$	$e$	$f$	
200 × 200	4V0 607	140	150	160	65	67	100	107	114	65	67	20
250 × 250	4V0 608	185	195	205	65	67	100	107	114	65	67	50
250 × 250	4V0 609	185	195	205	65	67	140	150	160	65	67	30
300 × 300	4V0 610	230	240	250	65	67	140	150	160	65	67	60
300 × 300	4V0 611	230	240	250	65	67	185	195	205	65	67	30
350 × 350	4V0 612	275	285	295	65	67	185	195	205	65	67	70
350 × 350	4V0 613	275	285	295	65	67	230	240	250	65	67	40
400 × 400	4V0 614	320	330	340	65	67	230	240	250	65	67	90
400 × 400	4V0 615	320	330	340	65	67	275	285	295	65	67	50
450 × 450	4V0 617	365	375	385	65	67	320	330	340	65	67	60

1) These reducing units have no flange.

2) The dimensions given here are the dimensions of the aperture brick; in practice they shall be reduced by the necessary clearance for installation.

### 3.1.8 Assembly of functional units

A diagram of functional units for 200 mm lead thickness is given in figure 28 for units of category 1 and in figure 25 for units of category 2.

In each of the diagrams, units such as aperture bricks (circular, rectangular and square), windows, plugs, sphere units and reducing units have been illustrated.

NOTE — All units are represented in their usual assembly direction but they can be reversed, except for

- in category 1 : 4V2 352
- in category 2 : 4V2 355  
4V2 356  
4V2 357  
4V2 358

which are fixed units.

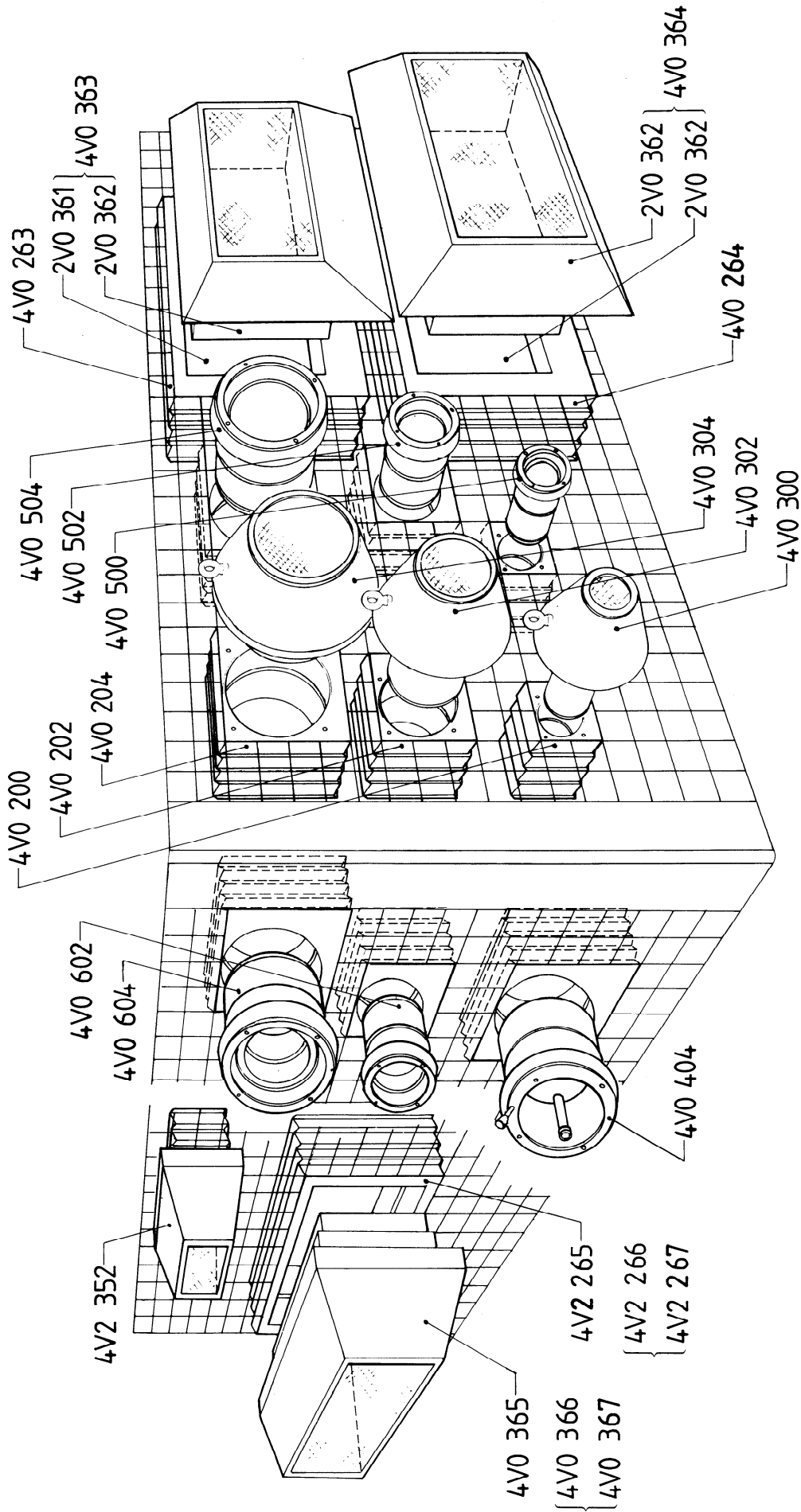

Figure 28 — General diagram of functional units for 200 mm lead thickness (category 1)

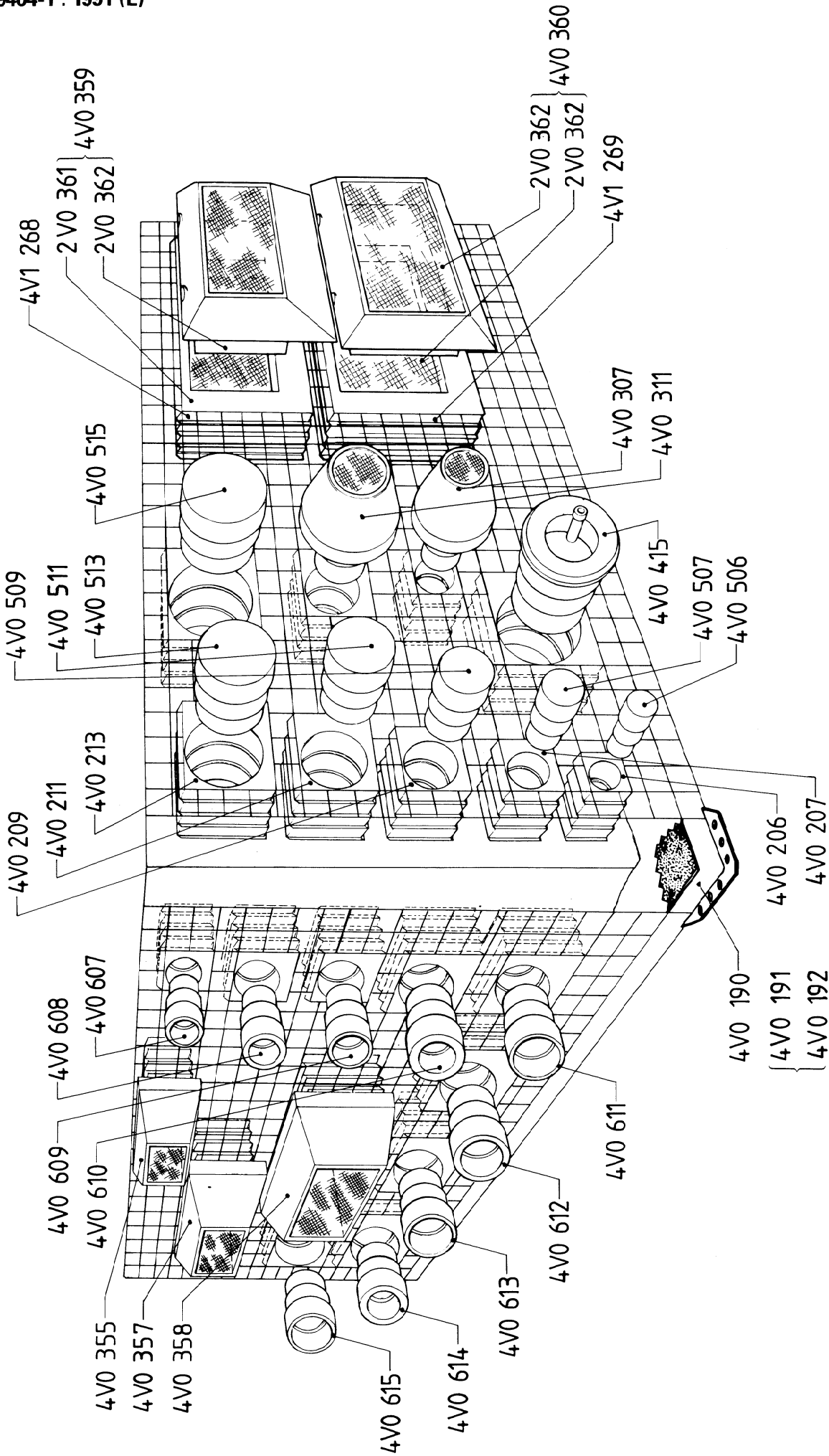

Figure 29 — General diagram of functional and corner units for 200 mm lead thickness (category 2)

## Section 4 : Tolerances

## 4.1 Tolerances

Table 39 gives tolerances for the functional dimensions of category 1 and 2 lead shielding elements.

Table 39 — Functional dimensions and tolerances for lead shielding units

Values in millimetres

Type of unit			Functional dimensions and tolerances			
Aperture bricks for circular units			$d_i$	$d_m$	$d_o$	
Reference number	Number of chevrons					
V0 200	3	4	170 $\begin{smallmatrix} + 0,25 \\ + 0,5 \end{smallmatrix}$		172 $\begin{smallmatrix} 0 \\ + 0,5 \end{smallmatrix}$	
V0 202	3	4	266 $\begin{smallmatrix} 0 \\ + 0,5 \end{smallmatrix}$		270 $\begin{smallmatrix} 0 \\ + 0,5 \end{smallmatrix}$	
V0 204	3	4	366 $\begin{smallmatrix} 0 \\ + 0,5 \end{smallmatrix}$		370 $\begin{smallmatrix} 0 \\ + 0,5 \end{smallmatrix}$	
V0 206	—	4	100 $\begin{smallmatrix} + 0,25 \\ + 0,38 \end{smallmatrix}$	107 $\begin{smallmatrix} + 0,25 \\ + 0,38 \end{smallmatrix}$	114 $\begin{smallmatrix} + 0,25 \\ + 0,38 \end{smallmatrix}$	
V0 207	3	—	150 $\begin{smallmatrix} 0 \\ + 0,2 \end{smallmatrix}$		160 $\begin{smallmatrix} 0 \\ + 0,2 \end{smallmatrix}$	
	—	4	140 $\begin{smallmatrix} 0 \\ + 0,2 \end{smallmatrix}$	150 $\begin{smallmatrix} 0 \\ + 0,2 \end{smallmatrix}$	160 $\begin{smallmatrix} 0 \\ + 0,2 \end{smallmatrix}$	
V0 209	3	—	195 $\begin{smallmatrix} 0 \\ + 0,2 \end{smallmatrix}$		205 $\begin{smallmatrix} 0 \\ + 0,2 \end{smallmatrix}$	
	—	4	185 $\begin{smallmatrix} 0 \\ + 0,2 \end{smallmatrix}$	195 $\begin{smallmatrix} 0 \\ + 0,2 \end{smallmatrix}$	205 $\begin{smallmatrix} 0 \\ + 0,2 \end{smallmatrix}$	
V0 211	3	—	240 $\begin{smallmatrix} 0 \\ + 0,2 \end{smallmatrix}$		250 $\begin{smallmatrix} 0 \\ + 0,2 \end{smallmatrix}$	
	—	4	230 $\begin{smallmatrix} 0 \\ + 0,2 \end{smallmatrix}$	240 $\begin{smallmatrix} 0 \\ + 0,2 \end{smallmatrix}$	250 $\begin{smallmatrix} 0 \\ + 0,2 \end{smallmatrix}$	
V0 213	3	—	285 $\begin{smallmatrix} 0 \\ + 0,2 \end{smallmatrix}$		295 $\begin{smallmatrix} 0 \\ + 0,2 \end{smallmatrix}$	
	—	4	275 $\begin{smallmatrix} 0 \\ + 0,2 \end{smallmatrix}$	285 $\begin{smallmatrix} 0 \\ + 0,2 \end{smallmatrix}$	295 $\begin{smallmatrix} 0 \\ + 0,2 \end{smallmatrix}$	
V0 215	—	4	320 $\begin{smallmatrix} 0 \\ + 0,2 \end{smallmatrix}$	330 $\begin{smallmatrix} 0 \\ + 0,2 \end{smallmatrix}$	340 $\begin{smallmatrix} 0 \\ + 0,2 \end{smallmatrix}$	
V0 217	—	4	365 $\begin{smallmatrix} 0 \\ + 0,2 \end{smallmatrix}$	375 $\begin{smallmatrix} 0 \\ + 0,2 \end{smallmatrix}$	385 $\begin{smallmatrix} 0 \\ + 0,2 \end{smallmatrix}$	
Aperture bricks for square and rectangular windows			$a$	$b$	$c$	$d$
Reference number	Number of chevrons					
V0 263	3	4	455 $\begin{smallmatrix} + 0,1 \\ + 0,35 \end{smallmatrix}$	655 $\begin{smallmatrix} + 0,1 \\ + 0,35 \end{smallmatrix}$	455 $\begin{smallmatrix} + 0,1 \\ + 0,35 \end{smallmatrix}$	655 $\begin{smallmatrix} + 0,1 \\ + 0,35 \end{smallmatrix}$
V0 264	3	4	655 $\begin{smallmatrix} + 0,1 \\ + 0,35 \end{smallmatrix}$	855 $\begin{smallmatrix} + 0,1 \\ + 0,35 \end{smallmatrix}$	655 $\begin{smallmatrix} + 0,1 \\ + 0,35 \end{smallmatrix}$	855 $\begin{smallmatrix} + 0,1 \\ + 0,35 \end{smallmatrix}$
V2 265	3	4	491 $\begin{smallmatrix} + 0,1 \\ + 0,35 \end{smallmatrix}$	791 $\begin{smallmatrix} + 0,1 \\ + 0,35 \end{smallmatrix}$	511 $\begin{smallmatrix} + 0,1 \\ + 0,35 \end{smallmatrix}$	811 $\begin{smallmatrix} + 0,1 \\ + 0,35 \end{smallmatrix}$
V2 266	3	4	421 $\begin{smallmatrix} + 0,1 \\ + 0,35 \end{smallmatrix}$	511 $\begin{smallmatrix} + 0,1 \\ + 0,35 \end{smallmatrix}$	441 $\begin{smallmatrix} + 0,1 \\ + 0,35 \end{smallmatrix}$	531 $\begin{smallmatrix} + 0,1 \\ + 0,35 \end{smallmatrix}$
V2 267	3	4	691 $\begin{smallmatrix} + 0,1 \\ + 0,35 \end{smallmatrix}$	891 $\begin{smallmatrix} + 0,1 \\ + 0,35 \end{smallmatrix}$	711 $\begin{smallmatrix} + 0,1 \\ + 0,35 \end{smallmatrix}$	911 $\begin{smallmatrix} + 0,1 \\ + 0,35 \end{smallmatrix}$
V1 268	3	—	455 $\begin{smallmatrix} + 0,1 \\ + 0,35 \end{smallmatrix}$	655 $\begin{smallmatrix} + 0,1 \\ + 0,35 \end{smallmatrix}$	555 $\begin{smallmatrix} + 0,1 \\ + 0,35 \end{smallmatrix}$	755 $\begin{smallmatrix} + 0,1 \\ + 0,35 \end{smallmatrix}$
	—	4	455 $\begin{smallmatrix} + 0,1 \\ + 0,35 \end{smallmatrix}$	655 $\begin{smallmatrix} + 0,1 \\ + 0,35 \end{smallmatrix}$	655 $\begin{smallmatrix} + 0,1 \\ + 0,35 \end{smallmatrix}$	855 $\begin{smallmatrix} + 0,1 \\ + 0,35 \end{smallmatrix}$

Table 39 (continued)

Values in millimetres

Type of unit			Functional dimensions and tolerances			
Aperture bricks for square and rectangular windows			<i>a</i>	<i>b</i>	<i>c</i>	<i>d</i>
Reference number	Number of chevrons					
V1 269	3	—	555 <sup>+ 0,1</sup> + 0,35	755 <sup>+ 0,1</sup> + 0,35	655 <sup>+ 0,1</sup> + 0,35	855 <sup>+ 0,1</sup> + 0,35
	—	4	655 <sup>+ 0,1</sup> + 0,35	855 <sup>+ 0,1</sup> + 0,35	655 <sup>+ 0,1</sup> + 0,35	855 <sup>+ 0,1</sup> + 0,35
Circular windows			<i>D<sub>i</sub></i>	<i>D<sub>m</sub></i>	<i>D<sub>o</sub></i>	
Reference number	Number of chevrons					
V0 300	3	—	169 <sup>0</sup> + 0,2			171,5 <sup>0</sup> - 0,2
	—	4	169,75 <sup>0</sup> - 0,2			171,5 <sup>0</sup> - 0,2
V0 302	3	4	265 <sup>0</sup> + 0,5			269 <sup>0</sup> + 0,5
V0 304	3	—	365 <sup>0</sup> + 0,5			369 <sup>0</sup> + 0,5
V0 307	3	—	149 <sup>+ 0,3</sup> + 0,5			159 <sup>+ 0,3</sup> + 0,5
	—	4	139 <sup>+ 0,3</sup> + 0,5	149 <sup>+ 0,3</sup> + 0,5		159 <sup>+ 0,3</sup> + 0,5
V0 311	3	—	239 <sup>+ 0,3</sup> + 0,5			249 <sup>+ 0,3</sup> + 0,5
	—	4	229 <sup>+ 0,3</sup> + 0,5	239 <sup>+ 0,3</sup> + 0,5		249 <sup>+ 0,3</sup> + 0,5
Square and rectangular windows			<i>a</i>	<i>b</i>	<i>c</i>	<i>d</i>
Reference number	Number of chevrons					
V0 363	3	4	454 <sup>+ 0,45</sup> + 0,7	654 <sup>+ 0,45</sup> + 0,7	454 <sup>+ 0,45</sup> + 0,7	654 <sup>+ 0,45</sup> + 0,7
V0 364	3	4	654 <sup>+ 0,45</sup> + 0,7	854 <sup>+ 0,45</sup> + 0,7	654 <sup>+ 0,45</sup> + 0,7	854 <sup>+ 0,45</sup> + 0,7
V0 365	3	4	490 <sup>+ 0,45</sup> + 0,7	790 <sup>+ 0,45</sup> + 0,7	510 <sup>+ 0,45</sup> + 0,7	810 <sup>+ 0,45</sup> + 0,7
V0 366	3	4	420 <sup>+ 0,45</sup> + 0,7	510 <sup>+ 0,45</sup> + 0,7	440 <sup>+ 0,45</sup> + 0,7	530 <sup>+ 0,45</sup> + 0,7
V0 367	3	4	690 <sup>+ 0,45</sup> + 0,7	890 <sup>+ 0,45</sup> + 0,7	710 <sup>+ 0,45</sup> + 0,7	910 <sup>+ 0,45</sup> + 0,7
V0 368	3	4	690 <sup>+ 0,45</sup> + 0,7	890 <sup>+ 0,45</sup> + 0,7	710 <sup>+ 0,45</sup> + 0,7	910 <sup>+ 0,45</sup> + 0,7
Sphere units			<i>D<sub>i</sub></i>	<i>D<sub>m</sub></i>	<i>D<sub>o</sub></i>	
Reference number	Number of chevrons					
V0 402	3	—	265 <sup>+ 0,5</sup> + 0,87			269 <sup>+ 0,5</sup> + 0,87
V0 404	—	4	364 <sup>0</sup> + 0,2			368 <sup>0</sup> + 0,2
V0 411	3	—	239 <sup>+ 0,3</sup> + 0,5			249 <sup>+ 0,3</sup> + 0,5
V0 415	—	4	318 <sup>+ 0,3</sup> + 0,5	328 <sup>+ 0,3</sup> + 0,5		338 <sup>+ 0,3</sup> + 0,5

Table 39 (concluded)

Values in millimetres

Type of unit			Functional dimensions and tolerances		
Reducing units			$D_i/d_i$	$D_m/d_m$	$D_o/d_o$
Reference number	Number of chevrons				
V0 602	3	4	264 <sup>0</sup> + 0,2		268 <sup>0</sup> + 0,2
	3	4	170 <sup>0</sup> + 0,25 + 0,5		172 <sup>0</sup> + 0,5
V0 604	3	4	364 <sup>0</sup> + 0,2		368 <sup>0</sup> + 0,2
	3	4	266 <sup>0</sup> + 0,5		270 <sup>0</sup> + 0,5
V0 607	—	4	139 <sup>+ 0,3</sup> + 0,5	149 <sup>+ 0,3</sup> + 0,5	159 <sup>+ 0,3</sup> + 0,5
	—	4	99 <sup>+ 0,3</sup> + 0,5	106 <sup>+ 0,3</sup> + 0,5	113 <sup>+ 0,3</sup> + 0,5
V0 608	—	4	184 <sup>+ 0,3</sup> + 0,5	194 <sup>+ 0,3</sup> + 0,5	204 <sup>+ 0,3</sup> + 0,5
	—	4	99 <sup>+ 0,3</sup> + 0,5	106 <sup>+ 0,3</sup> + 0,5	113 <sup>+ 0,3</sup> + 0,5
V0 609	3	—	194 <sup>+ 0,3</sup> + 0,5		204 <sup>+ 0,3</sup> + 0,5
	—	4	184 <sup>+ 0,3</sup> + 0,5	194 <sup>+ 0,3</sup> + 0,5	204 <sup>+ 0,3</sup> + 0,5
	3	—	150 <sup>0</sup> + 0,2		160 <sup>0</sup> + 0,2
	—	4	140 <sup>0</sup> + 0,2	150 <sup>0</sup> + 0,2	160 <sup>0</sup> + 0,2
V0 610	3	—	239 <sup>+ 0,3</sup> + 0,5		249 <sup>+ 0,3</sup> + 0,5
	3	—	150 <sup>0</sup> + 0,2		160 <sup>0</sup> + 0,2
V0 611	3	—	239 <sup>+ 0,3</sup> + 0,5		249 <sup>+ 0,3</sup> + 0,5
	—	4	229 <sup>+ 0,3</sup> + 0,5	239 <sup>+ 0,3</sup> + 0,5	249 <sup>+ 0,3</sup> + 0,5
	3	—	195 <sup>0</sup> + 0,2		205 <sup>0</sup> + 0,2
	—	4	140 <sup>0</sup> + 0,2	150 <sup>0</sup> + 0,2	160 <sup>0</sup> + 0,2
V0 612	—	4	274 <sup>+ 0,3</sup> + 0,5	284 <sup>+ 0,3</sup> + 0,5	294 <sup>+ 0,3</sup> + 0,5
	—	4	185 <sup>0</sup> + 0,8	195 <sup>0</sup> + 0,2	205 <sup>0</sup> + 0,2
V0 613	3	—	284 <sup>+ 0,3</sup> + 0,5		294 <sup>+ 0,3</sup> + 0,5
	—	4	274 <sup>+ 0,3</sup> + 0,5	284 <sup>+ 0,3</sup> + 0,5	294 <sup>+ 0,3</sup> + 0,5
	3	—	240 <sup>0</sup> + 0,2		250 <sup>0</sup> + 0,2
	—	4	230 <sup>0</sup> + 0,2	240 <sup>0</sup> + 0,2	250 <sup>0</sup> + 0,2
V0 614	—	4	319 <sup>+ 0,3</sup> + 0,3	329 <sup>+ 0,3</sup> + 0,5	339 <sup>+ 0,3</sup> + 0,5
	—	4	230 <sup>0</sup> + 0,2	240 <sup>0</sup> + 0,2	250 <sup>0</sup> + 0,2
V0 615	—	4	319 <sup>+ 0,3</sup> + 0,5	329 <sup>+ 0,3</sup> + 0,5	339 <sup>+ 0,3</sup> + 0,5
	—	4	275 <sup>0</sup> + 0,2	285 <sup>0</sup> + 0,2	295 <sup>0</sup> + 0,2
V0 617	—	4	365 <sup>0</sup> + 0,2	375 <sup>0</sup> + 0,2	385 <sup>0</sup> + 0,2
	—	4	320 <sup>0</sup> + 0,2	330 <sup>0</sup> + 0,2	340 <sup>0</sup> + 0,2

**Annex A**  
(informative)

**Bibliography**

- [1] ISO 468: 1982, *Surface roughness — Parameters, their values and general rules for specifying requirements.*
- [1] ISO 1302: 1978, *Technical drawings — Method of indicating surface texture on drawings.*
- [3] ISO 7212: 1986, *Enclosures for protection against ionizing radiation — Lead shielding units for 50 mm and 100 mm thick walls.*



This page intentionally left blank

This page intentionally left blank

This page intentionally left blank

ISO 9404-1 : 1991 (E)

---

---

**UDC 621.039 : 62-758-034.4**

**Descriptors :** nuclear energy, radiation protection, shielding, lead, bricks, classification, specifications, dimensions, designation.

Price based on 44 pages

---

---