**Optics and optical instruments —
Microscopes: Imaging distances related
to mechanical reference planes —**

**Part 2:
Infinity-corrected optical systems**

*Optique et instruments d'optique — Microscopes: Tirages mécaniques
en fonction des plans mécaniques de référence —*

Partie 2: Systèmes d'optique corrigés à l'infini



PDF disclaimer

This PDF file may contain embedded typefaces. In accordance with Adobe's licensing policy, this file may be printed or viewed but shall not be edited unless the typefaces which are embedded are licensed to and installed on the computer performing the editing. In downloading this file, parties accept therein the responsibility of not infringing Adobe's licensing policy. The ISO Central Secretariat accepts no liability in this area.

Adobe is a trademark of Adobe Systems Incorporated.

Details of the software products used to create this PDF file can be found in the General Info relative to the file; the PDF-creation parameters were optimized for printing. Every care has been taken to ensure that the file is suitable for use by ISO member bodies. In the unlikely event that a problem relating to it is found, please inform the Central Secretariat at the address given below.

© ISO 2003

All rights reserved. Unless otherwise specified, no part of this publication may be reproduced or utilized in any form or by any means, electronic or mechanical, including photocopying and microfilm, without permission in writing from either ISO at the address below or ISO's member body in the country of the requester.

ISO copyright office
Case postale 56 • CH-1211 Geneva 20
Tel. + 41 22 749 01 11
Fax + 41 22 749 09 47
E-mail copyright@iso.org
Web www.iso.org

Published in Switzerland

Foreword

ISO (the International Organization for Standardization) is a worldwide federation of national standards bodies (ISO member bodies). The work of preparing International Standards is normally carried out through ISO technical committees. Each member body interested in a subject for which a technical committee has been established has the right to be represented on that committee. International organizations, governmental and non-governmental, in liaison with ISO, also take part in the work. ISO collaborates closely with the International Electrotechnical Commission (IEC) on all matters of electrotechnical standardization.

International Standards are drafted in accordance with the rules given in the ISO/IEC Directives, Part 2.

The main task of technical committees is to prepare International Standards. Draft International Standards adopted by the technical committees are circulated to the member bodies for voting. Publication as an International Standard requires approval by at least 75 % of the member bodies casting a vote.

Attention is drawn to the possibility that some of the elements of this document may be the subject of patent rights. ISO shall not be held responsible for identifying any or all such patent rights.

ISO 9345-2 was prepared by Technical Committee ISO/TC 172, *Optics and optical instruments*, Subcommittee SC 5, *Microscopes and endoscopes*.

ISO 9345 consists of the following parts, under the general title *Optics and optical instruments — Microscopes: Imaging distances related to mechanical reference planes*:

- *Part 1: Tube length 160 mm*
- *Part 2: Infinity-corrected optical systems*

Optics and optical instruments — Microscopes: Imaging distances related to mechanical reference planes —

Part 2: Infinity-corrected optical systems

1 Scope

This part of ISO 9345 specifies the imaging distances of objectives, eyepieces and the focal length of “normal” tube lenses of microscopes with infinity-corrected optical systems.

NOTE A specific combination of eyepiece, objective and tube lens is frequently used to correct aberrations. Therefore the combination of an objective from one manufacturer and the tube lens or eyepiece from another manufacturer, although conforming to this part of ISO 9345, may cause errors in magnification and/or in optical performance.

2 Normative references

The following referenced documents are indispensable for the application of this document. For dated references, only the edition cited applies. For undated references, the latest edition of the referenced document (including any amendments) applies.

ISO 8039:1997, *Optics and optical instruments — Microscopes — Magnification*

ISO 9345-1:1996, *Optics and optical instruments — Microscopes — Imaging distances related to mechanical reference planes — Part 1: Tube length 160 mm*

3 Terms and definitions

For the purposes of this document, the following terms and definitions apply.

3.1

parfocalizing distance of the objective

l_1

distance between the object plane (i.e. the uncovered surface of the object) and the locating flange of the objective when the microscope is in its (focused) working condition

NOTE See Figure 1, Figure 2 and footnote b in Table 1.

3.2

image distance of the objective

l_2

distance in air between the objective locating surface and the primary image plane

NOTE An infinity-corrected objective alone produces a primary image at infinity. In combination with an infinity-corrected tube lens, the primary image is produced in the back focal plane of this tube lens (see Figure 1).

3.3 parfocalizing distance of the eyepiece

l_3
distance between the locating flange of the eyepiece and the plane upon which the eyepiece is focused

NOTE This plane is coincident with the primary image plane of the microscope when the eyepiece is mounted in the viewing tube (see Figure 1).

3.4 focal length of the “normal” tube lens

f_{NLT}
focal length related to the magnification and the focal length of the objectives which are designed to operate with this tube lens

[ISO 8039]

4 Requirements

4.1 Nominal dimensions and tolerances

The nominal dimensions shall be as given in Table 1 and as illustrated in Figure 1.

Table 1 — Nominal dimensions and tolerances

Feature	Symbol	Nominal values/range mm	Numerical aperture	Tolerance mm
Parfocalizing distance of objective ^{a, b}	l_1	$45 + 15 n$ ($n = -1, 0, 1, 2, 3, 4$)	$\leq 0,1$ $> 0,1$ to $\leq 0,25$ $> 0,25$ to $\leq 0,45$ $> 0,45$	$\pm 0,2^c$ $\pm 0,06$ $\pm 0,03$ $\pm 0,01$
Image distance of objective ^d	l_2	∞		
Parfocalizing distance of eyepiece	l_3	10		$\pm 0,2$
Focal length of “normal” tube lens ^e	f_{NLT}	$150 \leq f_{NLT} \leq 250$		

^a The choice of a parfocalizing distance for an objective depends on the design concept of the microscope as a whole. The parfocalizing distance, $l_1 = 45$ mm of objectives has become the standard value for microscopes with tube length 160 mm (see ISO 9345-1) and also has been adopted for various existing infinity-corrected microscope systems. Examples of common values in use are given in Annex A.

^b The parfocalizing distance, l_1 , shown in Figure 1 and Table 1, is intended to apply to objectives when used with uncovered objects (specimens). Objectives for use with objects covered by a cover glass shall have the following parfocalizing distance, to allow for the virtual displacement of the object by the cover glass (see also Figure 2):

$$l_1 + t \frac{n-1}{n} \text{ mm}$$

where

- t is the thickness of cover glass;
- n is the refractive index of the cover glass.

^c The tolerance $\pm 0,2$ mm for the parfocalizing distance of objectives with numerical aperture $\leq 0,1$ does not necessarily apply to objectives with magnifications lower than $4 \times$.

^d In infinity-corrected optical systems the primary image is always produced by the objective in combination with a tube lens. The distance between the locating flange of the objective and the tube lens depends on the design of the microscope. The microscope shall have such a design that, in combination with objectives and tube lenses in accordance with this part of ISO 9345, the primary image is produced 10 mm below the eyepiece-locating surface of the viewing tube.

^e The choice of focal length for a “normal” tube lens depends on the design concept of the microscope system. Its value shall be in the range of $150 \text{ mm} \leq f_{NLT} \leq 250 \text{ mm}$. Examples of common values in use are given in Annex A.

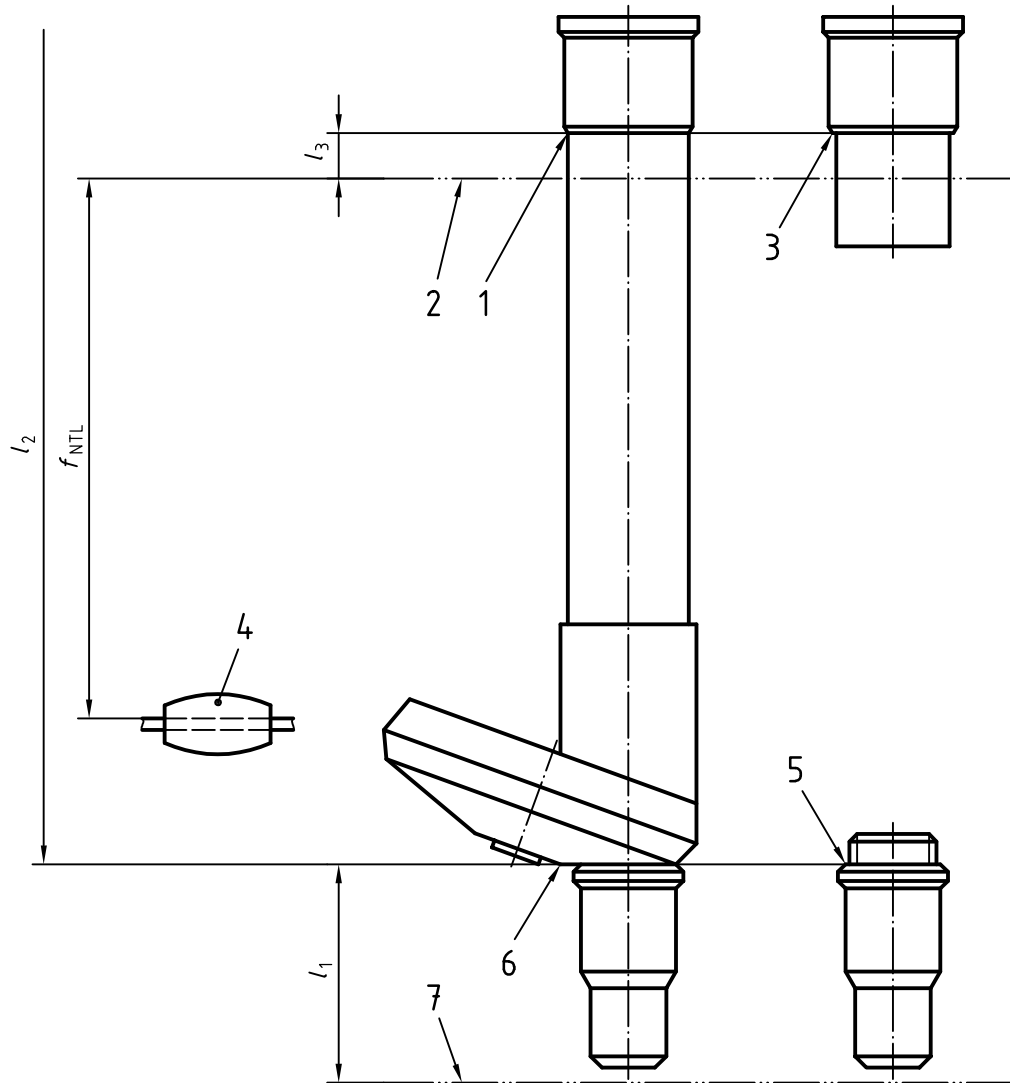

Key

- 1 eyepiece-locating surface of the viewing tube
- 2 primary image plane
- 3 locating flange of the eyepiece
- 4 tube lens
- 5 locating flange of the objective
- 6 objective-locating surface (of the nosepiece)
- 7 object plane

Figure 1 — Locating surfaces, reference planes and imaging distances

4.2 Examples

Figure 2 illustrates the influence of different cover glass thicknesses on the parfocalizing distance.

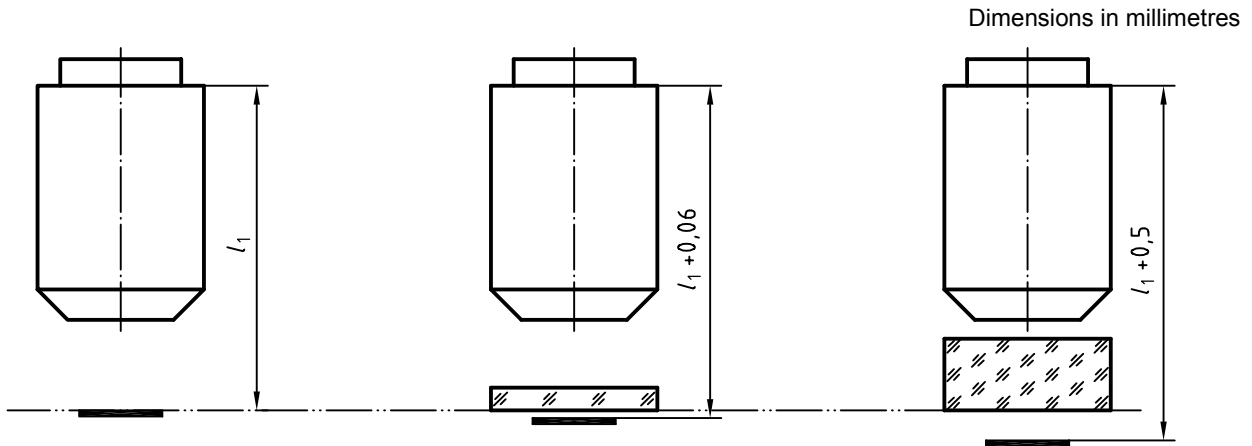

Uncovered object $t = 0 \text{ mm}$	Object with cover glass $t = 0,17 \text{ mm thickness}$ $n = 1,5$	Object with culture chamber $t = 1,5 \text{ mm bottom thickness}$ $n = 1,5$
$l_{CG} = l_1^a$	$l_{CG} = l_1 + 0,06 \text{ mm}^a$	$l_{CG} = l_1 + 0,5 \text{ mm}^a$
^a l_{CG} is the resulting parfocalizing distance due to different cover glass thickness.		

Figure 2 — Examples of parfocalizing distances as function of cover glass thickness

5 Marking

If the magnification of the primary image is changed by built-in optical systems, the tube factor shall be marked on the magnification changing component (stand, tube etc.); e.g. 1,25 ×.

Annex A (informative)

Examples of dimensions in use

Table A.1 shows the nominal values l_1 , l_2 , l_3 and f_{NTL} used by the main microscope manufacturers (in alphabetical order) at the time of publication of this part of ISO 9345.

Table A.1 — Examples of dimensions l_1 , l_2 , l_3 and f_{NTL} in use

Dimensions in millimetres

Feature	Leica	Nikon	Olympus	Zeiss
Parfocalizing distance of objective, l_1	45	45/60	45	45
Image distance of objective, l_2	∞	∞	∞	∞
Parfocalizing distance of eyepiece, l_3	10	10	10	10
Focal length of "normal" tube lens, f_{NTL}	200	200	180	160

Annex B (informative)

Requirements and recommendations for OEM-use of objectives and tube lenses

B.1 General

In case of adaptation of infinity-corrected objectives and tube lenses to instruments and equipment other than the microscopes of the manufacturer the user of these components needs additional dimensional information from the manufacturer for proper assembly.

This annex contains recommendations for the minimum information that should be transferred to the OEM.

NOTE A specific combination of eyepiece, objective and tube lens is frequently used to correct aberrations. Therefore the combination of an objective from one manufacturer and the tube lens or eyepiece from another manufacturer, although conforming to this part of ISO 9345, may cause errors in magnification and/or in optical performance.

B.2 Terms and definitions

B.2.1

image distance of the tube lens

l_{NTL}
distance between the primary image plane and the locating flange of the tube lens

NOTE It depends on the optical and mechanical design concept and is an important dimension for OEM use.

B.2.2

distance between objective and tube lens

d_{∞}
distance between the locating flange of the objective and the locating flange of the tube lens

NOTE It depends on the optical and mechanical design concept. To ensure correct optical performance for OEM the indication of the minimum and maximum value is recommended.

B.3 Recommended information for the user

See Figure B.1.

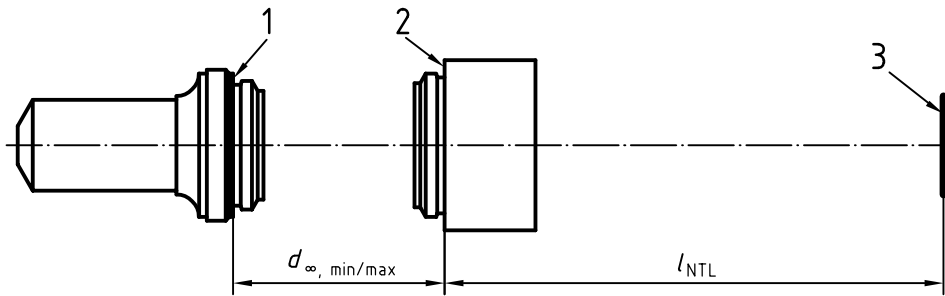

Key

- 1 locating flange of the objective
- 2 locating flange of the tube lens
- 3 primary image

NOTE The external dimensions of the tube lens mount, the method of fixing (screw thread etc.) and the screw thread of the objectives (see ISO 8038-1 and ISO 8038-2) for which it is designed and the position of the locating flange should be indicated by the manufacturer.

Figure B.1 — Assembling dimensions for objectives and tube lenses

1
2
3
4
5
6
7
8
9
10
11
12
13
14
15
16
17
18
19
20
21
22
23
24
25
26
27
28
29
30
31
32
33
34
35
36
37
38
39
40
41
42
43
44
45
46
47
48
49
50
51
52
53
54
55
56
57
58
59
60
61
62
63
64
65
66
67
68
69
70
71
72
73
74
75
76
77
78
79
80
81
82
83
84
85
86
87
88
89
90
91
92
93
94
95
96
97
98
99
100

Vertical line of text, possibly a page number or reference, oriented vertically.

ICS 37.020

Price based on 8 pages