

INTERNATIONAL
STANDARD

ISO
9344

Third edition
2016-11-15

**Microscopes — Graticules for
eyepieces**

Microscopes — Réticules pour oculaires



Reference number
ISO 9344:2016(E)

© ISO 2016



COPYRIGHT PROTECTED DOCUMENT

© ISO 2016, Published in Switzerland

All rights reserved. Unless otherwise specified, no part of this publication may be reproduced or utilized otherwise in any form or by any means, electronic or mechanical, including photocopying, or posting on the internet or an intranet, without prior written permission. Permission can be requested from either ISO at the address below or ISO's member body in the country of the requester.

ISO copyright office
Ch. de Blandonnet 8 • CP 401
CH-1214 Vernier, Geneva, Switzerland
Tel. +41 22 749 01 11
Fax +41 22 749 09 47
copyright@iso.org
www.iso.org

Contents

Page

Foreword	iv
1 Scope	1
2 Normative references	1
3 Terms and definitions	1
4 Requirements	1
4.1 Dimensions	1
4.2 Permissible material defects and processing faults	2
5 Marking	2

Foreword

ISO (the International Organization for Standardization) is a worldwide federation of national standards bodies (ISO member bodies). The work of preparing International Standards is normally carried out through ISO technical committees. Each member body interested in a subject for which a technical committee has been established has the right to be represented on that committee. International organizations, governmental and non-governmental, in liaison with ISO, also take part in the work. ISO collaborates closely with the International Electrotechnical Commission (IEC) on all matters of electrotechnical standardization.

The procedures used to develop this document and those intended for its further maintenance are described in the ISO/IEC Directives, Part 1. In particular the different approval criteria needed for the different types of ISO documents should be noted. This document was drafted in accordance with the editorial rules of the ISO/IEC Directives, Part 2 (see www.iso.org/directives).

Attention is drawn to the possibility that some of the elements of this document may be the subject of patent rights. ISO shall not be held responsible for identifying any or all such patent rights. Details of any patent rights identified during the development of the document will be in the Introduction and/or on the ISO list of patent declarations received (see www.iso.org/patents).

Any trade name used in this document is information given for the convenience of users and does not constitute an endorsement.

For an explanation on the meaning of ISO specific terms and expressions related to conformity assessment, as well as information about ISO's adherence to the World Trade Organization (WTO) principles in the Technical Barriers to Trade (TBT) see the following URL: www.iso.org/iso/foreword.html.

The committee responsible for this document is ISO/TC 172, *Optics and photonics*, Subcommittee SC 5 *Microscopes and endoscopes*.

This third edition cancels and replaces the second edition (ISO 9344:2011), which has been technically revised to add ISO 10110-7 and ISO 10110-8 in the normative references; see also [Table 2](#).

Microscopes — Graticules for eyepieces

1 Scope

This document specifies dimensions and permissible material defects and processing faults for graticules with diameters of 19 mm, 21 mm and 26 mm to be used in microscope eyepieces for the purposes of measurement, assessment and comparison.

2 Normative references

The following documents are referred to in the text in such a way that some or all of their content constitutes requirements of this document. For dated references, only the edition cited applies. For undated references, the latest edition of the referenced document (including any amendments) applies.

ISO 10110-1, *Optics and photonics — Preparation of drawings for optical elements and systems — Part 1: General*

ISO 10110-3, *Optics and optical instruments — Preparation of drawings for optical elements and systems — Part 3: Material imperfections — Bubbles and inclusions*

ISO 10110-4, *Optics and optical instruments — Preparation of drawings for optical elements and systems — Part 4: Material imperfections — Inhomogeneity and striae*

ISO 10110-5, *Optics and photonics — Preparation of drawings for optical elements and systems — Part 5: Surface form tolerances*

ISO 10110-7, *Optics and photonics — Preparation of drawings for optical elements and systems — Part 7: Surface imperfection tolerances*

ISO 10110-8, *Optics and photonics — Preparation of drawings for optical elements and systems — Part 8: Surface texture; roughness and waviness*

3 Terms and definitions

No terms and definitions are listed in this document.

ISO and IEC maintain terminological databases for use in standardization at the following addresses:

- IEC Electropedia: available at <http://www.electropedia.org/>
- ISO Online browsing platform: available at <http://www.iso.org/obp>

4 Requirements

4.1 Dimensions

[Table 1](#) specifies the dimensions for Type 1 and Type 2 graticules.

Table 1 — Dimensions of graticules

Dimensions in millimetres

Parameter	Type 1	Type 2
Diameter ^{a, d}	19 ⁰ _{-0,1}	19 ⁰ _{-0,033}
	21 ⁰ _{-0,1}	21 ⁰ _{-0,033}
	26 ⁰ _{-0,1}	26 ⁰ _{-0,033}
Thickness	1,0	1,0
	1,5	1,5
Protective chamfer in accordance with ISO 10110-1	0,1 to 0,3	0,1 to 0,3
^a Other diameters are also permitted if they comply with the specified thickness and the requirements listed in Table 2 .		

4.2 Permissible material defects and processing faults

[Table 2](#) specifies the permissions for Type 1 and Type 2 graticules.

5 Marking

To differentiate the commonly used Type 1 graticule from the smaller tolerance Type 2 graticule, the marking "Type 2 conforming to ISO 9344" shall be placed on the graticule itself or on the graticule packaging.

Table 2 — Permissible material defects and processing faults

Criterion	Reference for specification	Test region ^a	Minimum requirement
Bubbles	ISO 10110-3	1 2	$1/2 \times 0,016^b$ $1/2 \times 0,025^b$
Striae	ISO 10110-4	—	2/—; 3 ^c
Surface form tolerances	ISO 10110-5	—	3/6 (3) ^d
Surface imperfections for each side	ISO 10110-7	1 2	$5/2 \times 0,016^b$; L2 $\times 0,002 5^e$ $5/2 \times 0,025^b$; L2 $\times 0,004^e$
Surface quality	ISO 10110-8	—	f P3 
Parallelism tolerance	—	—	$\leq 10'$

^a For an illustration of the test regions, see Figure 1.

^b Code for defect/permissible number of defects multiplied by the square root of the maximum area of the largest defect, in mm².
EXAMPLE $1/2 \times 0,1$ indicates two bubble defects with a maximum area of 0,01 mm² per bubble.

^c The dash following the defect code indicates that the inhomogeneities are unspecified; the digit 3 indicates the class of striae, which may have the following effective areas, in reference to the diameter of the graticule plate:

Diameter, mm	19	21	26
Striae class	3	3	3
Striae area, mm ²	5	6	10

^d In accordance with ISO 10110-5, the first number after the defect code represents the maximum permissible sagitta deviation, whereas the number in brackets gives the maximum permissible value of irregularity. The number of fringe spacings is only used as the unit in this document.

^e Two scratches of unspecified length and the maximum width with the grade number 0,002 5 mm (0,004 mm for one scratch) are permissible. The symbol L indicates long scratch longer than 2 mm in ISO 10110-7. However, it means merely scratch with unspecified length in this document.

^f Polished surface with less than 16 microdefects per 10 mm scan line.

Dimensions in millimetres

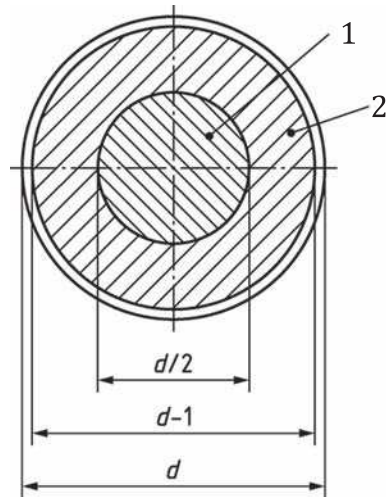

Key

- 1 test region 1
- 2 test region 2

Figure 1 — Test regions

