

INTERNATIONAL STANDARD

ISO 9315

First edition
1989-07-15

Information processing systems — Interface between flexible disk cartridge drives and their host controllers

*Systèmes de traitement de l'information — Interface entre dispositifs d'entraînement
pour cartouches de disques souples et leurs contrôleurs hôtes*



Reference number
ISO 9315 : 1989 (E)

Foreword

ISO (the International Organization for Standardization) is a worldwide federation of national standards bodies (ISO member bodies). The work of preparing International Standards is normally carried out through ISO technical committees. Each member body interested in a subject for which a technical committee has been established has the right to be represented on that committee. International organizations, governmental and non-governmental, in liaison with ISO, also take part in the work. ISO collaborates closely with the International Electrotechnical Commission (IEC) on all matters of electrotechnical standardization.

Draft International Standards adopted by the technical committees are circulated to the member bodies for approval before their acceptance as International Standards by the ISO Council. They are approved in accordance with ISO procedures requiring at least 75 % approval by the member bodies voting.

International Standard ISO 9315 was prepared by Technical Committee ISO/TC 97, *Information processing systems*.

© ISO 1989

All rights reserved. No part of this publication may be reproduced or utilized in any form or by any means, electronic or mechanical, including photocopying and microfilm, without permission in writing from the publisher.

International Organization for Standardization
Case postale 56 • CH-1211 Genève 20 • Switzerland

Printed in Switzerland

Information processing systems – Interface between flexible disk cartridge drives and their host controllers

1 Scope

This International Standard specifies a flexible disk cartridge drive and defines the necessary functional and electrical requirements (including logic signals) and the mechanical requirements of the interface for the connection of conforming flexible disk drives to a host system. It includes drives using media specified in many standards but does not exclude drives using other media.

This International Standard is distinct from a specification in that it delineates a minimum set of requirements consistent with compatibility and interchangeability at the interface level. This standard is intended to facilitate the interconnection of flexible disk drives to a host system by a user who has available the technical capability to verify test performance up through the functional level. The user should also have the capability of specifying the overall system hardware and software that will be unique for this particular device, and should also have the capability of specifying the controller combination for the desired application and end use.

This International Standard applies to both single- and double-sided disk drives using 200 mm (8 in) or 130 mm (5,25 in) envelope-size flexible disks. It does not prescribe the magnetic encoding or decoding method, the recording techniques, or the format used to write or read data. It does not apply to host/drive subsystems where there is no clear physical and functional separation between the host and its drive or drives. This standard, as originally developed, was written specifically for 200 mm and 130 mm flexible disk drives. However, the standard may be applied to other disk sizes. In particular, for smaller drive applications considering this standard it is recommended that smaller-size flexible disk drives and their controllers use the descriptions applicable to 130 mm flexible disk drives.

2 Definitions

For the purposes of this International Standard, the following definitions apply.

2.1 active filter: A network used to maintain compatibility with post-compensated flexible disk cartridges.

2.2 actuator: An electrically driven positioner for one or more read/write heads that are controlled by step and direction select signals.

2.3 cartridge: An assembly consisting of a jacket and a disk.

2.4 cylinder: The track(s) available under the read/write head at each radial head position. Each cylinder on a double-sided drive includes two tracks. On a single-sided drive, cylinders and tracks are synonymous.

2.5 disk: A flat circular device having a magnetic coating on at least one side.

2.6 disk drive: A mechanism consisting of a spindle to support and rotate a disk, one or more read/write heads positioned to read or write digital information on a track of the disk, an actuator to move the heads to any track, and logic circuits and amplifying circuits as required.

2.7 format: The arrangement of coded flux patterns on a track of a disk to represent tolerance gaps, preamble fields, address fields, data fields, sector marks, etc.

2.8 hard sectoring: The use of mechanical means such as multiplicity of holes in the index track to define fixed angular positions on the disk.

2.9 index hole track: A concentric track on a disk containing at least one round hole. It is used to establish a rotational reference position by photoelectric means. Some types of disk drives and media combinations use other equivalent means for this function, i.e. the use of a magnetized spot on the media hub along with a magnetic transducer in the drive.

2.10 jacket: An assembly consisting of outer cover and liner.

2.11 level: A term used to designate the following:

- a) A voltage level;
- b) One of two logic levels, high or low;
- c) A signal that remains fixed at a low or high level for the duration of a logical sequence, such as SELECT, DIRECTION, READY, as contrasted to a pulse.

2.12 logical false: The non-asserted or non-active state of a control signal. In this International Standard it is the high level of the signal (2,4 V to 5,25 V).

2.13 logical true: The asserted or active state of a control signal. In this International Standard it is the low level of the signal (0 V to 0,4 V).

2.14 mandatory: A term signifying that an item shall be provided by the source of the interface signal and need not be utilized by the receiver.

2.15 optional: A term signifying that an item may be used on certain configurations, but is not mandatory. If used it shall be used as defined in clause 3 and shall be on the connector pin defined in clause 3.

2.16 pulse: A signal that is asserted for a relatively brief time period during a logical sequence (a series of brief assertions).

2.17 read/write head: A magnetic recording and playback head. There may be one or more of these heads.

2.18 step: The function that locates one or more read/write heads over a particular track.

2.19 track: A concentric path on a magnetic surface of the disk on which data may be written and later recovered by a read operation.

2.20 vendor unique: A term signifying that use of a particular function is defined by the vendor.

3 Functional signals

Figure 1 for 200 mm (8 in) cartridge drives and figure 2 for 130 mm (5,25 in) cartridge disk drives list the functional signals required between the flexible disk drive and the host system. Included in the figures are the pin number assignments of the signal interface connector. The mandatory signals are required for the minimum interface. The optional signals, if implemented, shall appear on the pins assigned. The vendor unique function only exists when it is defined by the vendor.

3.1 Head current switch/active read filter

200 mm	M	To the drive	Pin 2; head current switch
	O	To the drive	active read filter
130 mm	V	To the drive	Pin 2
	V	To the host	

This interface signal is used for multiple functions, depending on whether the drive is in the write or the read mode and whether it is a 200 mm or 130 mm drive. This signal should be in a stable condition before attempting to read or write.

3.1.1 Head current switch — write mode

The signal used as head current switch is mandatory on 200 mm drives only. When this interface signal is true (low) and the disk drive is selected, the lower value of the write current is selected for a write operation on cylinders 43 (decimal) and

above. When this signal interface is false (high) and the disk drive is selected, the higher value of the write current is selected for a write operation on cylinders 0 (decimal) through 42 (decimal).

3.1.2 Active read filter — read mode

The signal used as active read filter is optional on 200 mm drives. When this interface signal is true (low) active and the disk drive is selected in a read operation, the read signal is passed through an active filter network to form composite read data (see 3.12) on cylinders 60 (decimal) and above. When this interface signal is false (high) inactive and the disk drive is selected in a read operation, the read signal is passed directly to form composite read data (see 3.12). The use of this signal eliminates the need for a write precompensation. When a flexible disk cartridge that has been recorded by using write precompensation is being read, this signal should remain in the false (high) inactive state.

3.2 Drive select (four signal lines)

200 mm	M	To the drive	Pins 26, 28, 30, 32; four lines mandatory
130 mm	M	To the drive	Pins 10, 12, 14; three lines mandatory Pin 6; optional

The SELECT lines provide a means of selecting and deselecting a disk drive. These four lines select one of the four disk drives attached to the controller. When the signal line logic level is true (low), the disk drive electronics are activated for the execution of any step or read/write commands that might be issued. When the signal line logic level is false (high), all input/output bus interface lines are deselected. If the head load signal (see 3.15) is not used, these lines are also used for the head load function.

3.3 Direction select

200 mm	M	To the drive	Pin 34
130 mm	M	To the drive	Pin 18

When the drive is selected, this interface signal defines the direction of motion of one or more read/write heads when the STEP (see 3.4) line is pulsed. If an open circuit or logical false (high) level is applied, the direction of motion is defined as "out", and if a pulse is applied to the STEP line the read/write heads will move away from the centre of the disk. Conversely, if a logical true (low) level is applied, the direction of motion is defined as "in", and if a pulse is applied to the STEP (see 3.4) line, the read/write heads will move toward the centre of the disk.

3.4 Step

200 mm	M	To the drive	Pin 36
130 mm	M	To the drive	Pin 20

When the drive is selected, this interface line is a control signal on which a pulse causes one or more read/write heads to be

moved one cylinder, with the direction of motion set by the DIRECTION SELECT line (see 3.3). The quiescent state is logical false (high).

3.5 Composite write data

200 mm M To the drive Pin 38

130 mm M To the drive Pin 22

When the drive is selected, this interface line provides the data to be written on the disk if the WRITE GATE (see 3.6) is active. Each transition from the logical false (high) level to the logical true (low) level causes the current through the selected read/write head to be reversed.

3.6 Write gate

200 mm M To the drive Pin 40

130 mm M To the drive Pin 24

When the drive is selected, a logical true (low) active level on this line enables composite write data (see 3.5) to be written on the disk. Erase timing is internally generated from the write gate.

3.7 Index

200 mm M To the host Pin 20

130 mm NA

This interface signal is pulsed logical true (low) by the selected drive once each revolution to indicate the beginning of the cylinder. The leading edge of this signal shall always be used to ensure timing accuracy. This interface signal may be a composite of the index and sector pulses. The index signal is always present; the sector signal appears only when hard sector cartridges are used and the drive is configured without index/sector separation.

3.8 Sector

200 mm O To the host Pin 24

130 mm NA

When a hard-sectored cartridge is being utilized, this interface signal is pulsed true (low) by the selected drive for each sector to indicate to the host the beginning of the sector. The leading edge of this signal shall always be used to ensure timing accuracy.

3.9 Drive ready

200 mm M To the host Pin 22

130 mm O To the host Pin 34

A logical true (low) active level on this line indicates that a cartridge is loaded properly and rotating in the selected drive and that the door is closed.

3.10 Cylinder 0

200 mm M To the host Pin 42

130 mm M To the host Pin 26

When the disk is selected, the CYLINDER 0 interface signal indicates to the host that one or more read/write heads are positioned on cylinder 0. The CYLINDER 0 signal remains logically true (low) until the heads are moved away from cylinder 0.

3.11 Write protected

200 mm M To the host Pin 44

130 mm M To the host Pin 28

When the disk drive is protected, this signal line logic level goes true (low) if the cartridge is write protected. The write electronics in the disk drive is internally disabled if the disk is write protected. When the level on this line is false (high), the write electronics is enabled and the write operation can be performed.

3.12 Composite read data

200 mm M To the host Pin 46

130 mm M To the host Pin 30

Data from the selected drive are provided as an output to the host system in the same form as write data from the host system. Each flux reversal sensed on the storage element will result in a pulse to the logical true (low) active level. The leading edge of this signal shall always be used to ensure timing accuracy.

3.13 Side one select

200 mm O To the drive Pin 14

130 mm O To the drive Pin 32

When the drive is selected, this interface signal defines which side of a two-sided cartridge is used for reading or writing. An open circuit, or logical false (high) level, selects the read/write head on the SIDE 0 surface of the cartridge. An active state, or logical true (low) level, selects the read/write head on the SIDE 1 surface of the cartridge.

3.14 In-use control

200 mm O To the drive Pin 16

130 mm O To the drive Pin 4

This line is assigned for special control functions available as optional configurations from various manufacturers. It may be qualified by drive select or for some functions used independently of drive select. Typical functions that may be implemented are busy indicator or door lock, or both. The protocol for this line is dependent upon the particular control function selected.

3.15 Head load

200 mm	O	To the drive	Pin 18
130 mm	O	To the drive	Pin 4

This interface signal line, when activated to a logical true (low) level and provided the cartridge access door is closed, will load one or more read/write heads against the disk.

3.16 Drive busy

200 mm	O	To the host	Pin 8
130 mm	NA		

This line is assigned for special status functions available as optional configurations available from various manufacturers. It may be qualified by drive select or for some functions used independently of drive select. Typical functions that may be implemented are write active or seek active.

3.17 Two-sided

200 mm	O	To the host	Pin 10
130 mm	NA		

This interface signal, when the drive is selected, indicates true (low) when a two-sided cartridge is installed and false (high) when a single-sided cartridge is installed.

3.18 Disk change

200 mm	O	To the host	Pin 12
130 mm	O	To the host	Pin 34

This interface signal indicates, when selected, a true level (low) if the ready signal has gone false (door opened) between DRIVE SELECT signals. The disk change circuit is reset false (high) on the true-to-false transition of DRIVE SELECT, provided that the drive is ready.

3.19 Separated read data

200 mm	O	To the host	Pin 48
130 mm	NA		

When the drive is selected, this signal will be a pulse for each "data one" bit read from the disk. The line will be at logical true (low) level during the time of the pulse and remaining logical false (high) level for each "data zero" bit read from the disk. The leading edge of this signal shall always be used to ensure timing accuracy.

3.20 Separated read clock

200 mm	O	To the host	Pin 50
130 mm	NA		

When the drive is selected, this line provides the signal that defines the bit-cell time of information read during a read

operation. The signal is a pulse, the leading edge of which defines the beginning of the new (next) bit cell. The line is at the logical true (low) level during the time of the pulse. The leading edge of this signal shall always be used to ensure timing accuracy.

NOTE — Separated read data and read clock are optional and may be used only with a particular recording method, i.e., double frequency (frequency modulation). These lines may lose synchronization during missing clock occurrences. The manufacturer of the drive should be consulted for the proper use of these lines.

3.21 Not assigned

200 mm	O	To the host	Pin 6
130 mm	NA		

This line is reserved for future use and shall not be used for any other purpose.

3.22 Motor on

200 mm	NA		
130 mm	M	To the drive	Pin 16

When the signal logic level goes true (low), the drive motor accelerates and stabilizes to normal speed. When the signal logic goes false (high), the drive motor decelerates toward stop.

3.23 Index/sector

200 mm	NA		
130 mm	M	To the host	Pin 8

This interface signal is pulsed logically true (low) by the selected drive once each revolution to indicate the beginning of a cylinder or sector. It may be a composite of the INDEX and the SECTOR pulses (see 3.7 and 3.8). The INDEX signal is always present. The SECTOR signal appears only when hard-sectored cartridges are used. The leading edge only of this signal contains accurate timing information to ensure media interchangeability.

3.24 Not assigned

200 mm	O	To the drive	Pin 4
130 mm	NA		

This line is reserved for future use and shall not be used for any other purpose.

4 Timing

Timing is defined in figures 3 to 14.

4.1 Power sequencing

A.c. and d.c. power may be applied to the drive in any sequence. However, for 200 mm drives, after the power used for the operation of the spindle motor is first applied, a 2 s delay

shall be introduced before any read or write operation is valid. There shall also be a 90 ms delay after d.c. power is applied, before a read, write, or seek operation may be initiated or before the status signals are valid. In addition the timing requirements of figures 10 and 12 shall be adhered to for 130 mm drives. After powering on, the initial position of one or more heads with respect to data cylinders is indeterminable; therefore, a step-out operation should be performed until the CYLINDER 0 indicator becomes active.

4.2 Drive selection

Drive selection occurs when a drive's drive select line is activated (e.g., after the d.c. power delay of 90 ms has passed for 200 mm drives). The drive's status lines shall be valid within 500 ns of drive selection.

4.3 Read/write data timing

Read/write data timing is given for illustration purposes only. Magnetic encoding and decoding as well as format characteristics are device dependent, and the responsibility for them remains with the user in consultation with the drive manufacturer.

5 Electrical requirements for signal interface

5.1 Multidrop bus

The signal and d.c. interface used by the flexible disk cartridge drive is of the multidrop bus type and allows an electrical connection as shown in figures 15 (a) and 15 (b). Only one drive is logically connected to the interface at any given time. The maximum length of the bus is 3 m (10 ft).

5.2 Voltage levels

Signals across the interface shall utilize voltage levels, measured at the driver, as follows:

Logical true: active low; + 0 V to + 0,4 V

Logical false: inactive high; + 2,4 V to + 5,25 V

5.3 Termination

The signal lines should be terminated at the receiving end by one of the networks shown in figure 16. This is achieved in the drive by means of a resistive terminating network that is located

only at the drive that is physically connected to the end of the primary interface. Drive-to-host signals shall be terminated at the host by a similar network.

5.4 Signal drivers

The signal drivers should have open collector output stages capable of sinking a minimum of 40 mA at a logical true (low) level, with a maximum voltage of 0,4 V measured from the driver output.

5.5 Signal receivers

The signal receivers shall not unduly load the multidrop bus. Each receiver should not require a current of more than 40 μ A from the driver at input high level (2,4 V) nor supply more than 1,6 mA to a current sink at input low level (0,4 V).

6 Mechanical description

6.1 Connectors

Interface connectors for the 130 mm and 200 mm drives are shown in figures 17 to 20.

6.2 Interconnecting cable characteristics

The characteristics of the interconnecting cable are specified in 6.2.1 to 6.2.3. An interconnecting cable may be composed of twisted or untwisted pair (flat cable). The maximum length from connector to connector shall be 3 m (10 ft).

6.2.1 Conductor size

The interconnecting cable shall be composed of a 0,05 mm² (30 AWG) or larger solid copper conductor; of 0,08 mm² (28 AWG) stranded copper wires; or of non-copper conductors of a size sufficient to yield a d.c. wire resistance not exceeding 361 Ω /km (110 Ω per 1 000 ft) per conductor.

6.2.2 Stray capacitance

The capacitance between one wire in the cable and all others in the cable sheath, with all others connected to ground, shall not exceed 131 pF/m (40 pF/ft) and shall be reasonably uniform for a given conductor over the length of the cable.

6.2.3 Mutual pair capacitance

The capacitance between one wire in the pair and the other wire shall not exceed 66 pF/m (20 pF/ft) and shall be reasonably uniform over the length of the cable.

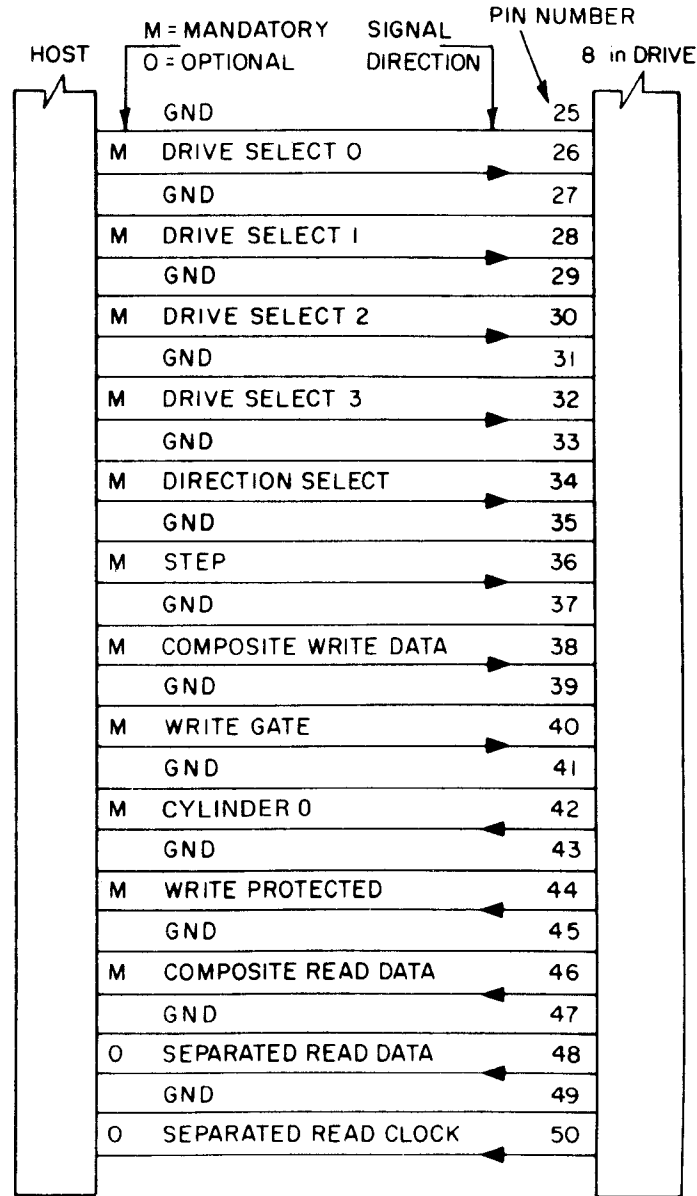
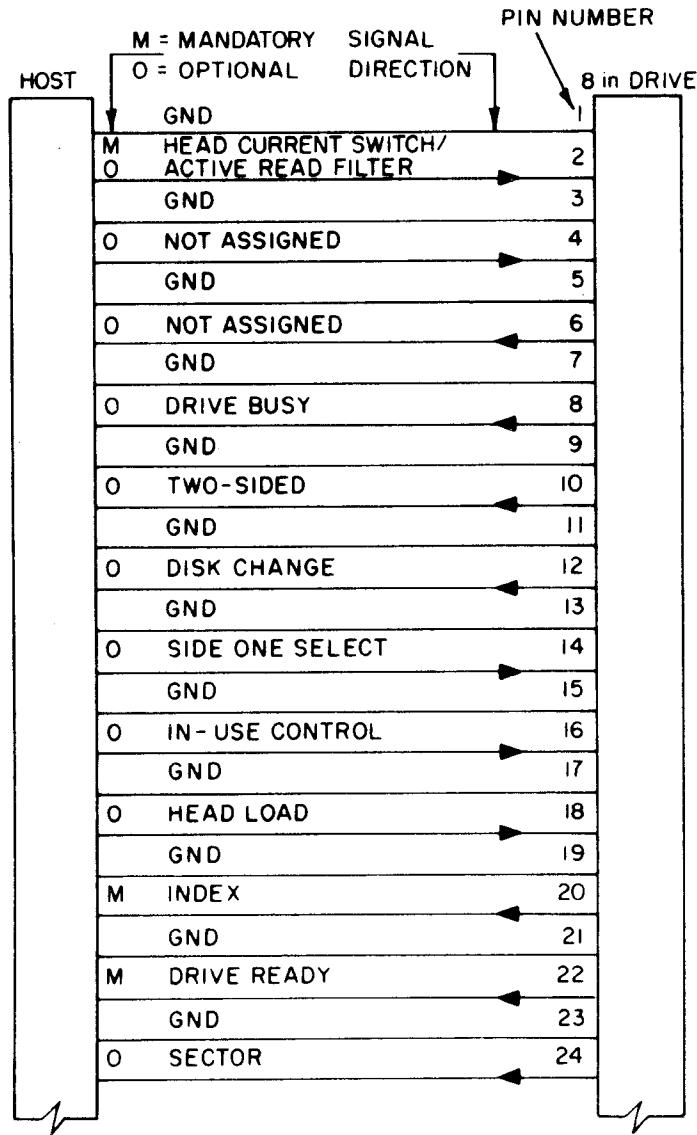

Figure 1 — 200 mm (8 in) cartridge drive signals

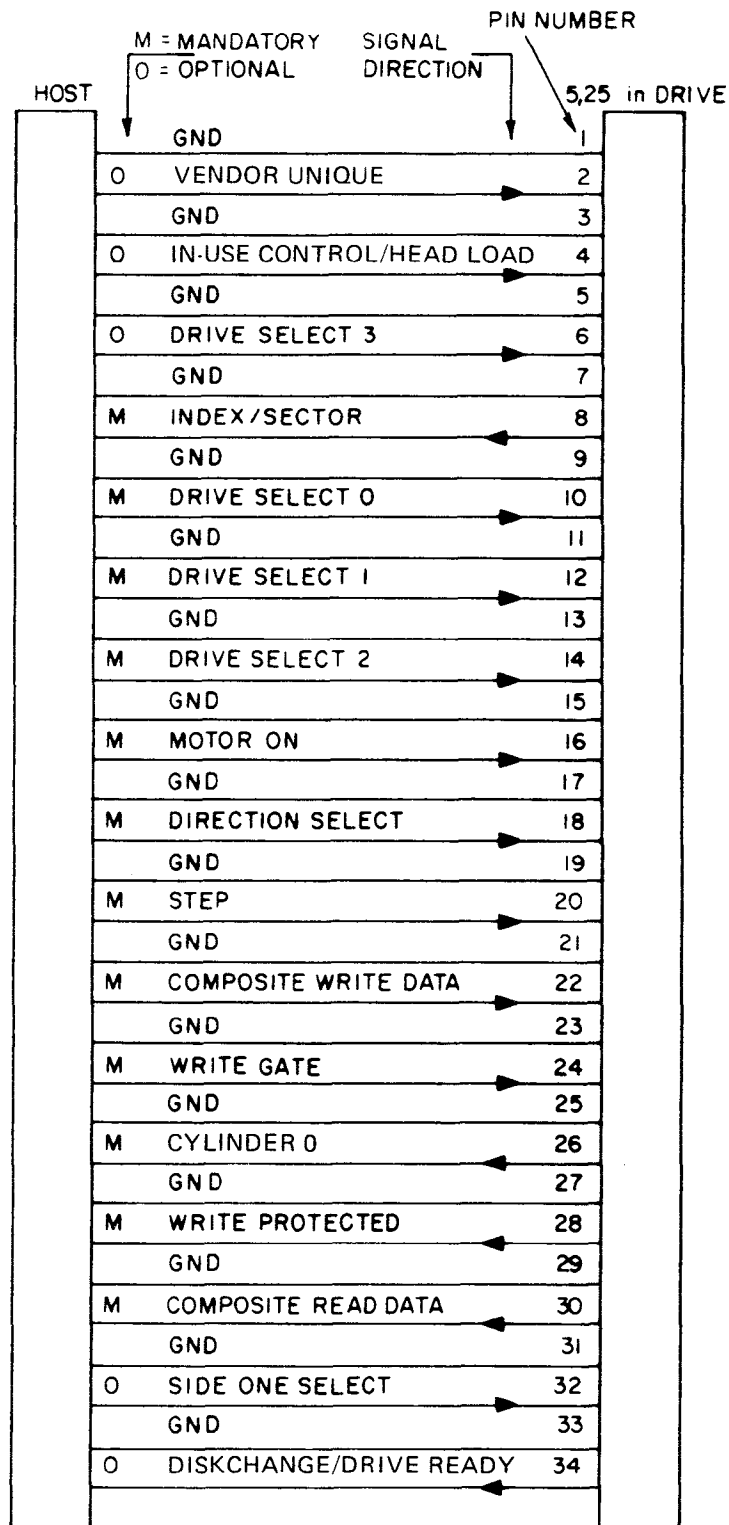
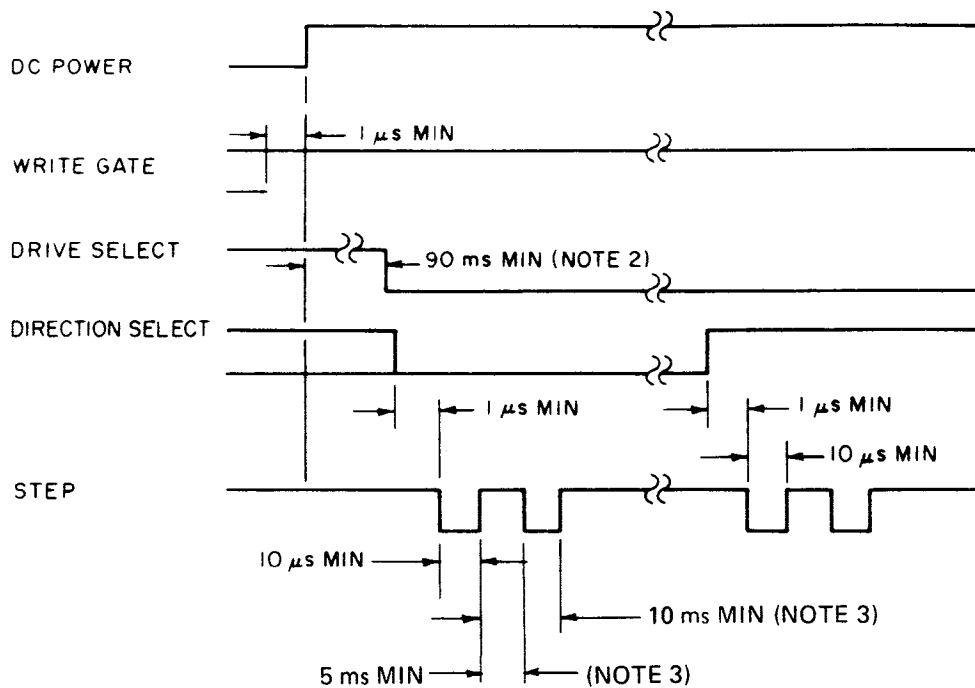

Figure 2 — 130 mm (5,25 in) cartridge drive signals



NOTES

- 1) Timing is measured at the host.
- 2) This interval will be 2 s if a.c. and d.c. power are applied at the same time.
- 3) Shorter delays may be vendor unique.

Figure 3 — Track access timing, 200 mm (8 in)

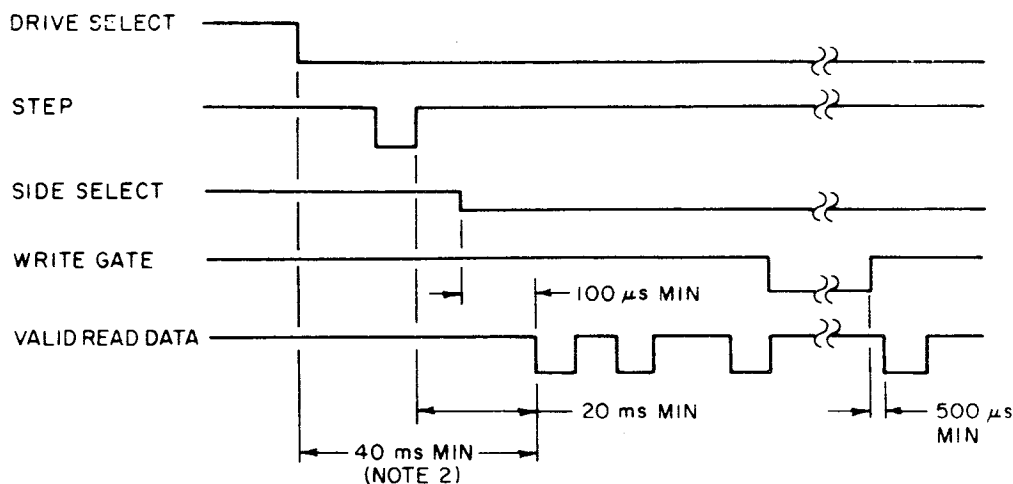

NOTES

- 1) Timing is measured at the host.
- 2) This interval is measured from the beginning of the head load signal.

Figure 4 — Read initiate timing, 200 mm (8 in)

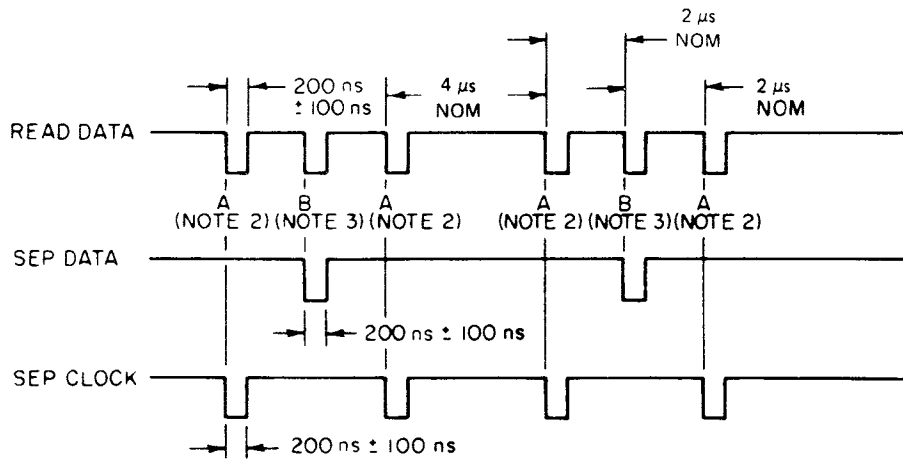

NOTES

- 1) Timing is measured at the drive.
- 2) A = the leading edge of the bit; A may be $\pm 500 \text{ ns}$ from its nominal position.
- 3) B = the leading edge of the bit; B may be $\pm 250 \text{ ns}$ its nominal position.
- 4) FM-encoded (250 kilobits per second) read timings are shown for illustration purposes only and are not part of this International Standard (see 4.3). For MFM-encoded (500 kilobits per second) read timings, see vendor specifications.

Figure 5 — Read data timing, 200 mm (8 in)

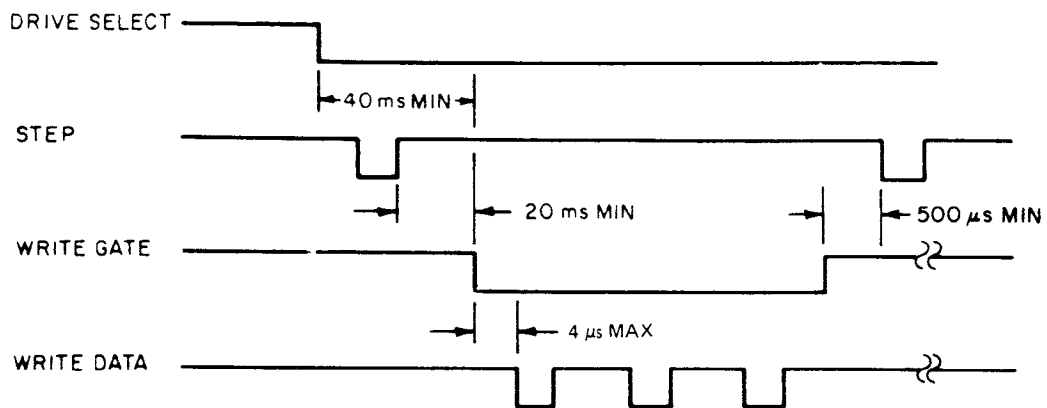

NOTE — Timing is measured at the host.

Figure 6 — Write initiate timing, 200 mm (8 in)

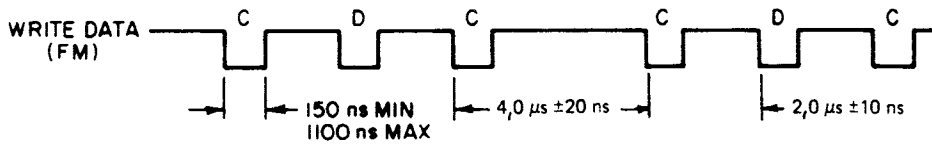

NOTES

- 1) Timing is measured at the host.
- 2) FM-encoded (250 kilobits per second) read timings are shown for illustration purposes only and are not part of this International Standard (see 4.3). For MFM-encoded (500 kilobits per second) read timings, see vendor specifications.

Figure 7 – Write data timing, 200 mm (8 in)

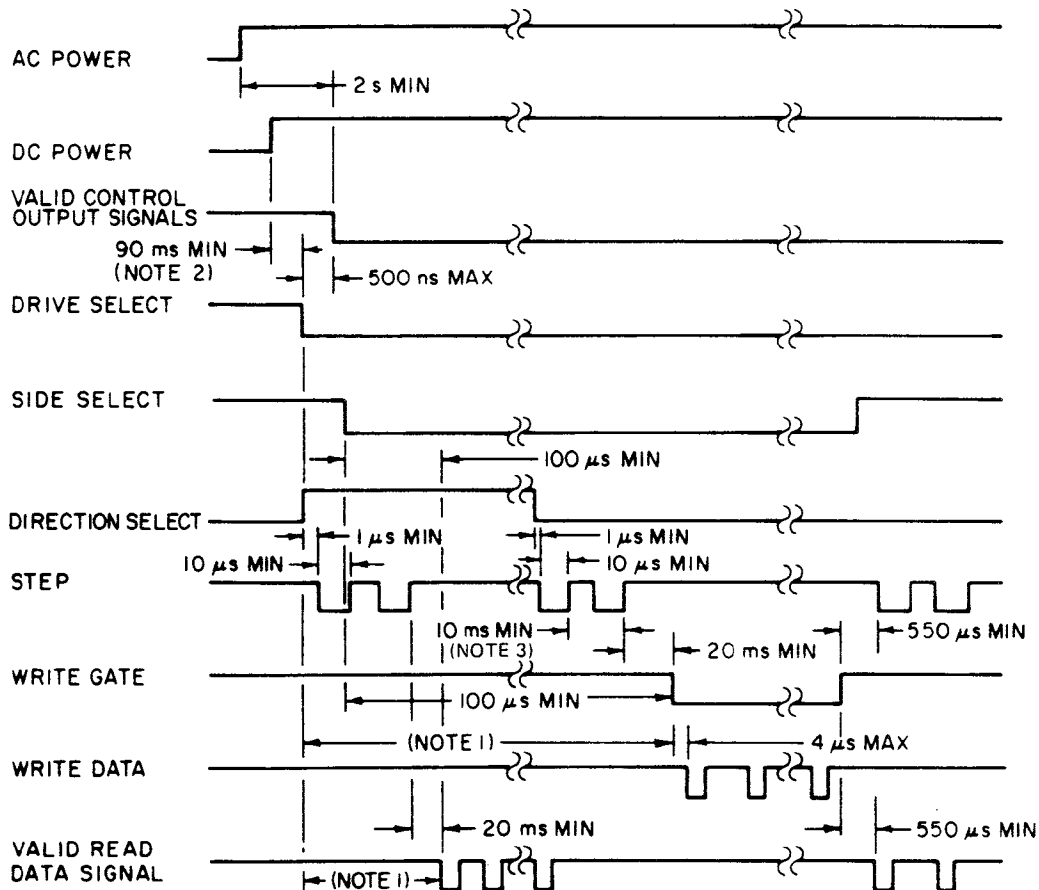

NOTES

- 1) 40 ms minimum delay must be introduced after drive select to allow for proper load setting.
- 2) This interval will be 2 s if a.c. and d.c. are applied at the same time.
- 3) Shorter delay may be vendor unique.

Figure 8 – General control data timing requirements, 200 mm (8 in)

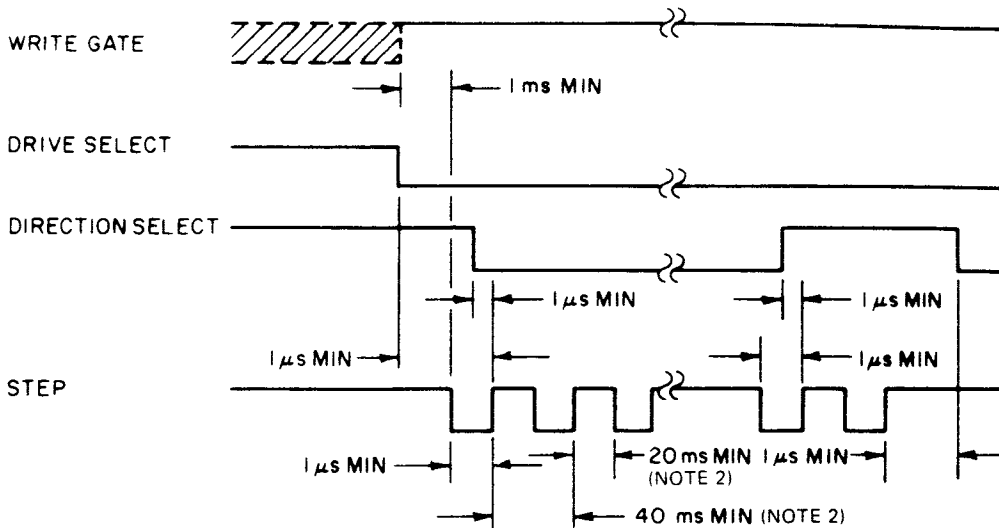

NOTES

- 1) Timing is measured at the host.
- 2) Shorter delays may be vendor unique.

Figure 9 — Track access timing, 130 mm (5,25 in)

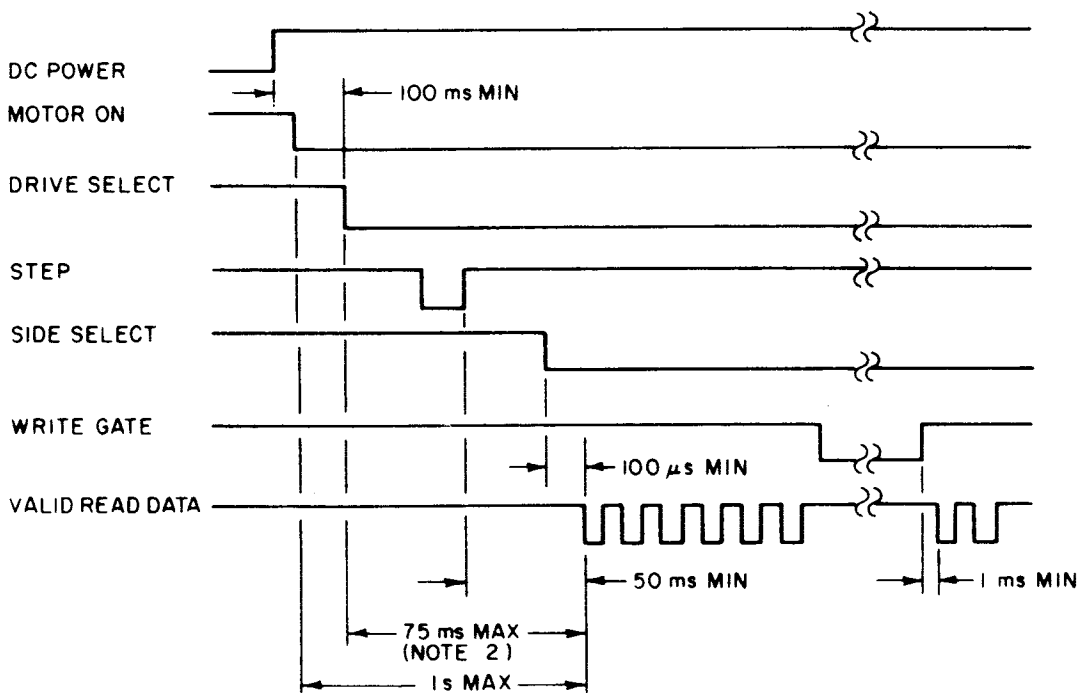

NOTES

- 1) Timing is measured at the drive.
- 2) This interval is measured from the beginning of the head load signal.
- 3) For drives providing "automatic head positioning at cylinder 0 after power on" option, see vendor specifications.

Figure 10 — Read initiate timing, 130 mm (5,25 in)

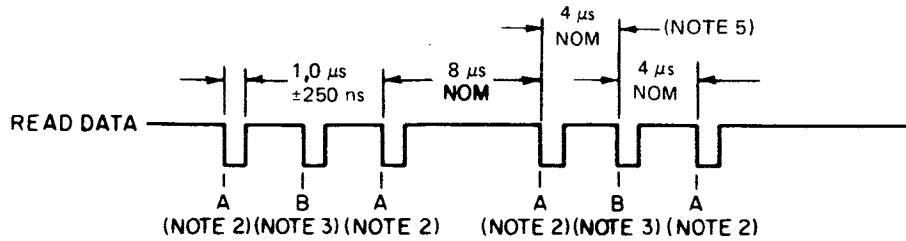

NOTES

- 1) Timing is measured at the host.
- 2) A = the leading edge of the bit; A may be $\pm 1 \mu\text{s}$ from its nominal position.
- 3) B = the leading edge of the bit; B may be $\pm 500 \text{ ns}$ from its nominal position.
- 4) FM-encoded (250 kilobits per second) read timings are shown for illustration purposes only and are not part of this International Standard (see 4.3). For MFM-encoded (500 kilobits per second) read timings, see vendor specifications.
- 5) $2 \mu\text{s}$, $4 \mu\text{s}$ may be vendor unique.

Figure 11 — Read data timing, 130 mm (5,25 in)

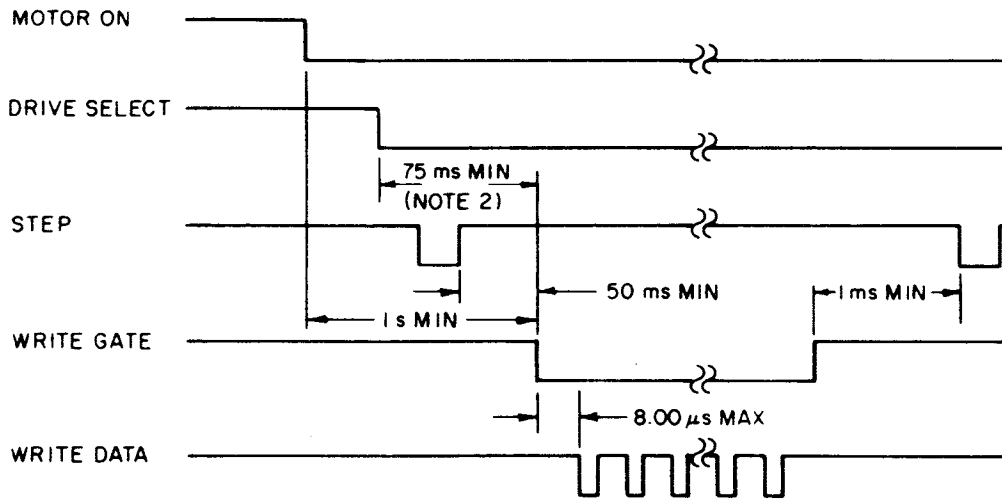

NOTES

- 1) Timing is measured at the host.
- 2) This interval is measured from the beginning of the head load signal.

Figure 12 — Write initiate timing, 130 mm (5,25 in)

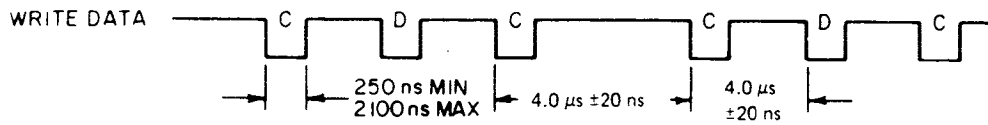

NOTES

- 1) Timing is measured at the host.
- 2) FM-encoded (250 kilobits per second) read timings are shown for illustration purposes only and are not part of this International Standard (see 4.3). For MFM-encoded (500 kilobits per second) read timings, see vendor specifications.
- 3) $4 \mu\text{s} \pm 20 \text{ ns}$ may be vendor unique.

Figure 13 — Write data timing, 130 mm (5,25 in)

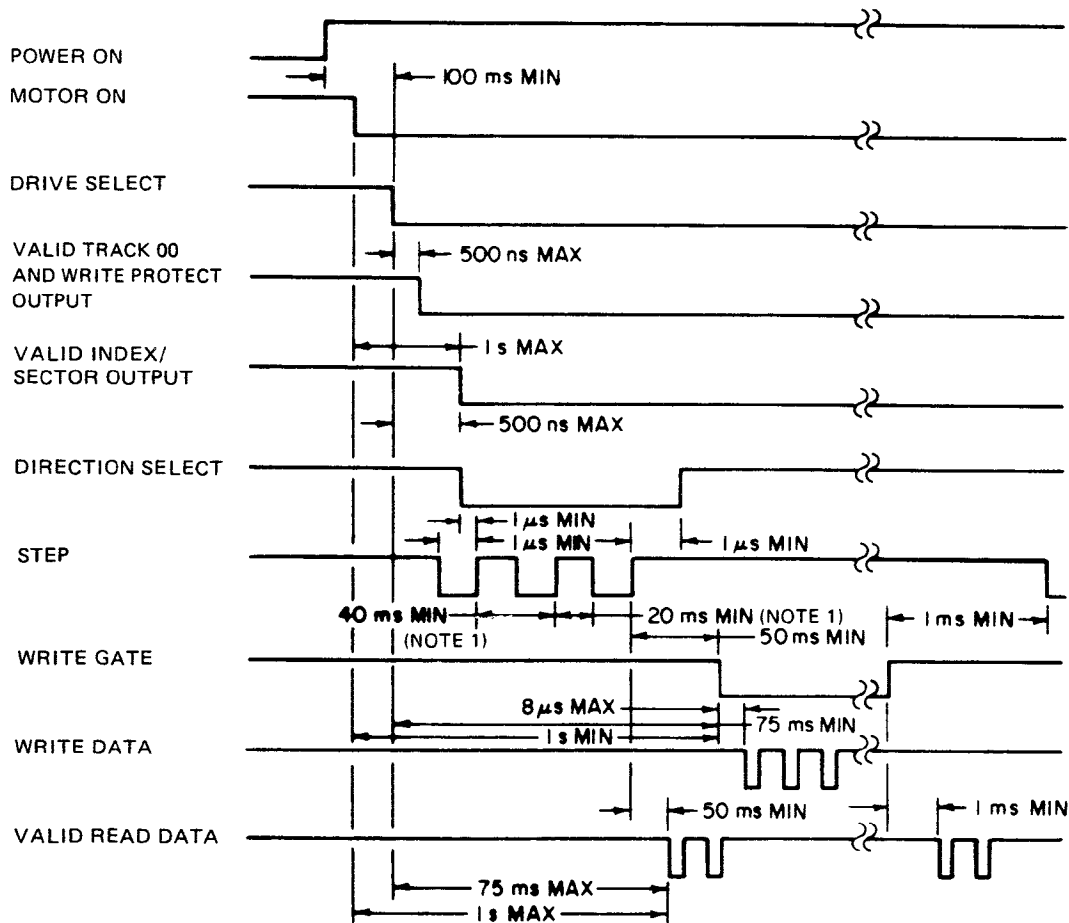

NOTES

- 1) The leading edge timing may be shorter, if vendor unique.
- 2) For drives providing "automatic head positioning at cylinder 0 after power on" option, see vendor specifications.

Figure 14 — General control and data timing requirements, 130 mm (5,25 in)

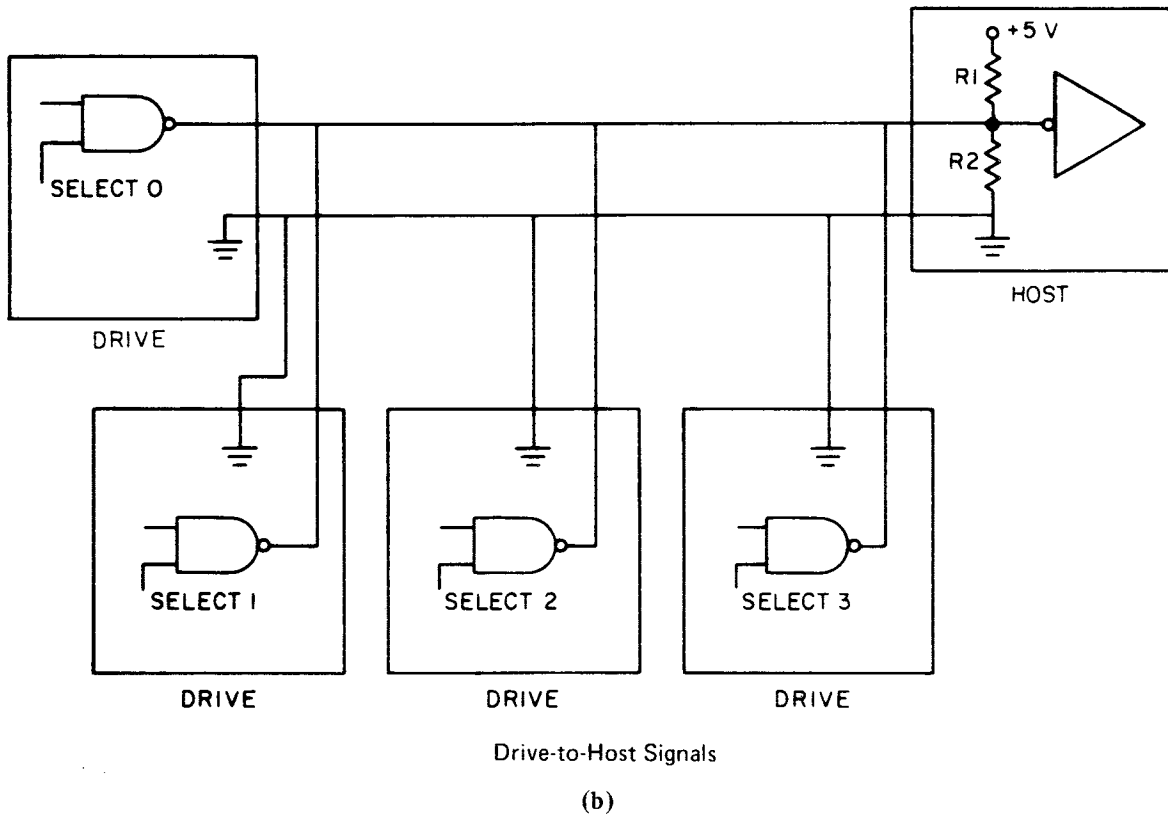
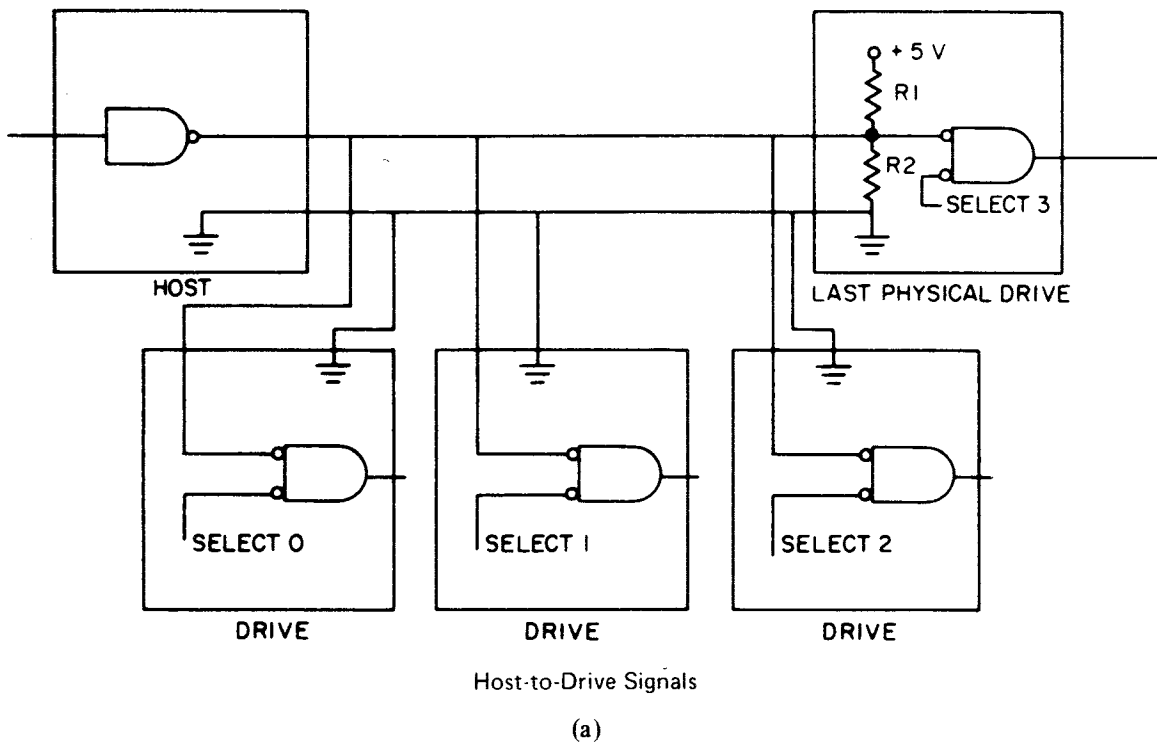

Figure 15 — Interface interconnect circuit scheme

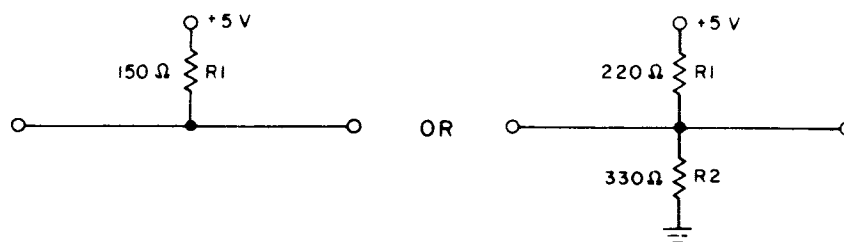
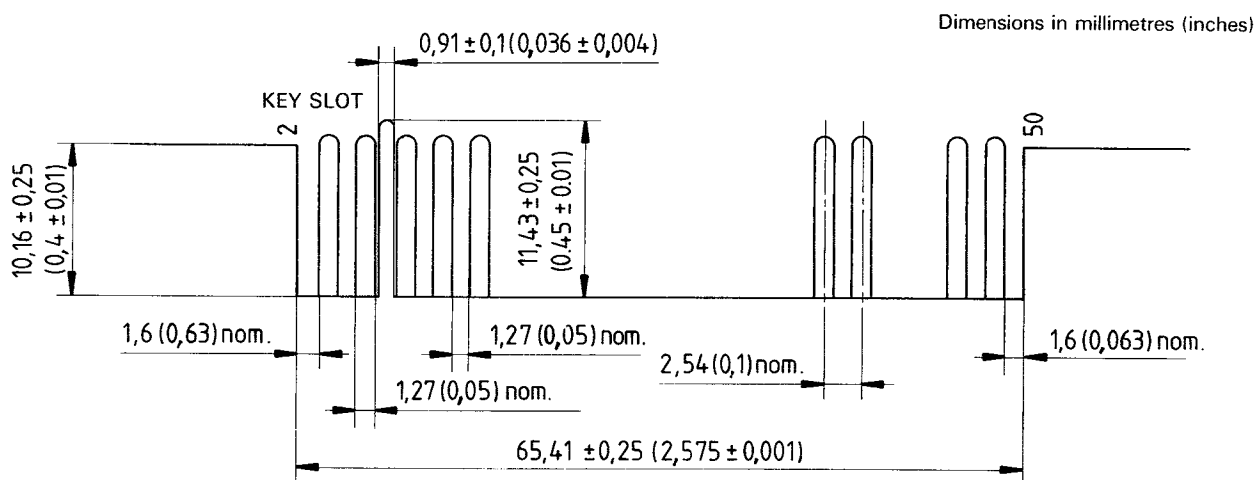
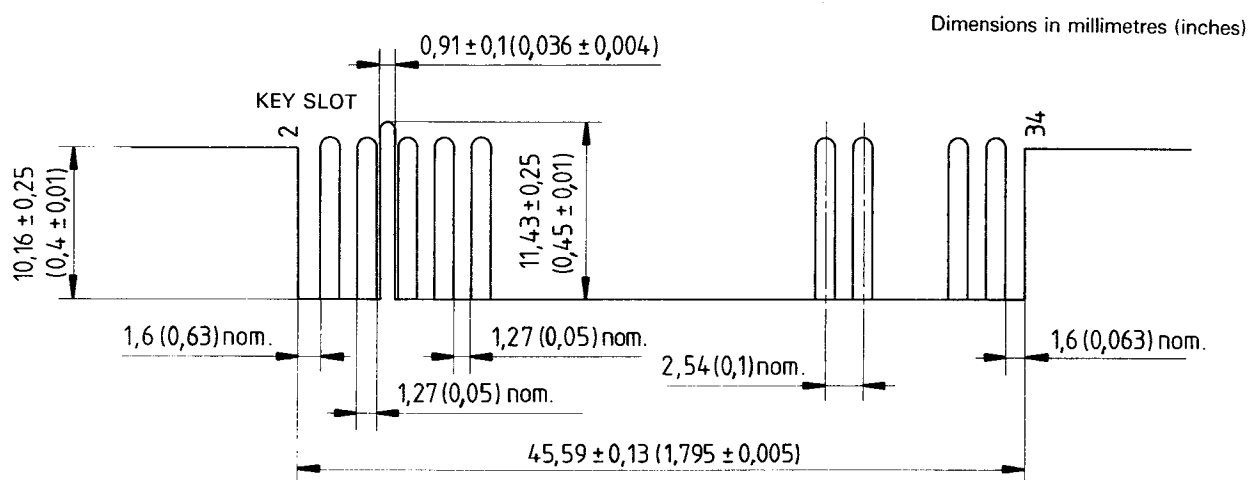

Figure 16 – Resistive termination networks



NOTE – Board thickness shall be 1,57 mm ± 0,18 mm (0,062 in ± 0,007 in).

Figure 17 – Signal interface, edge connector on 200 mm (8 in) drive



NOTE – Board thickness shall be 1,57 mm ± 0,18 mm (0,062 in ± 0,007 in).

Figure 18 – Signal interface, edge connector on 130 mm (5,25 in) drive

Dimensions in millimetres (inches)

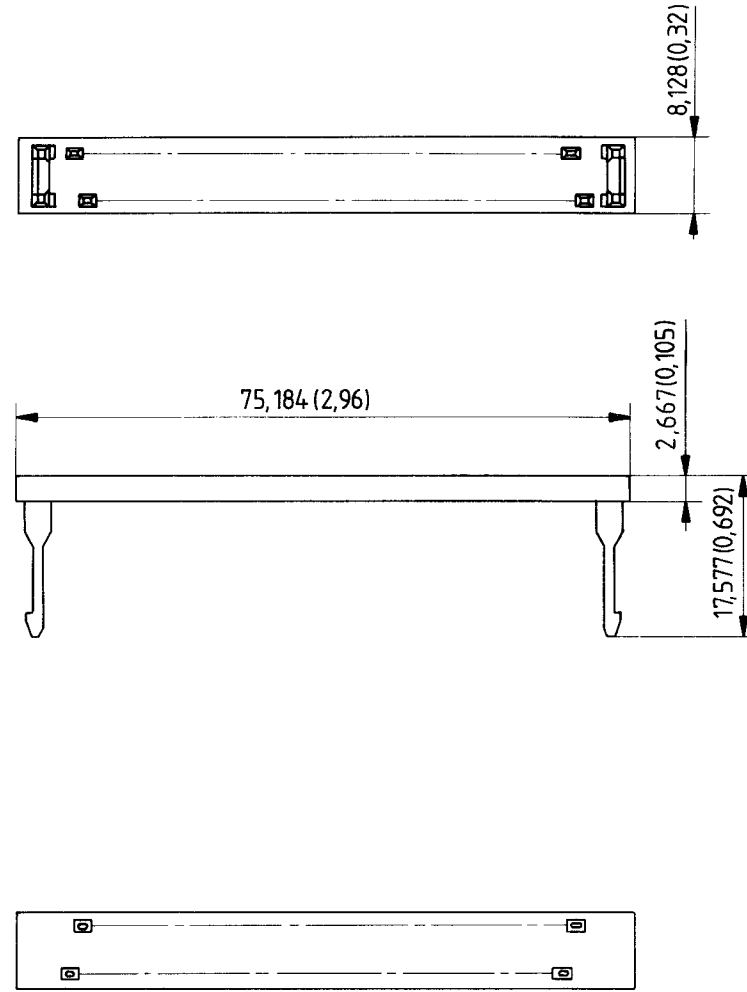
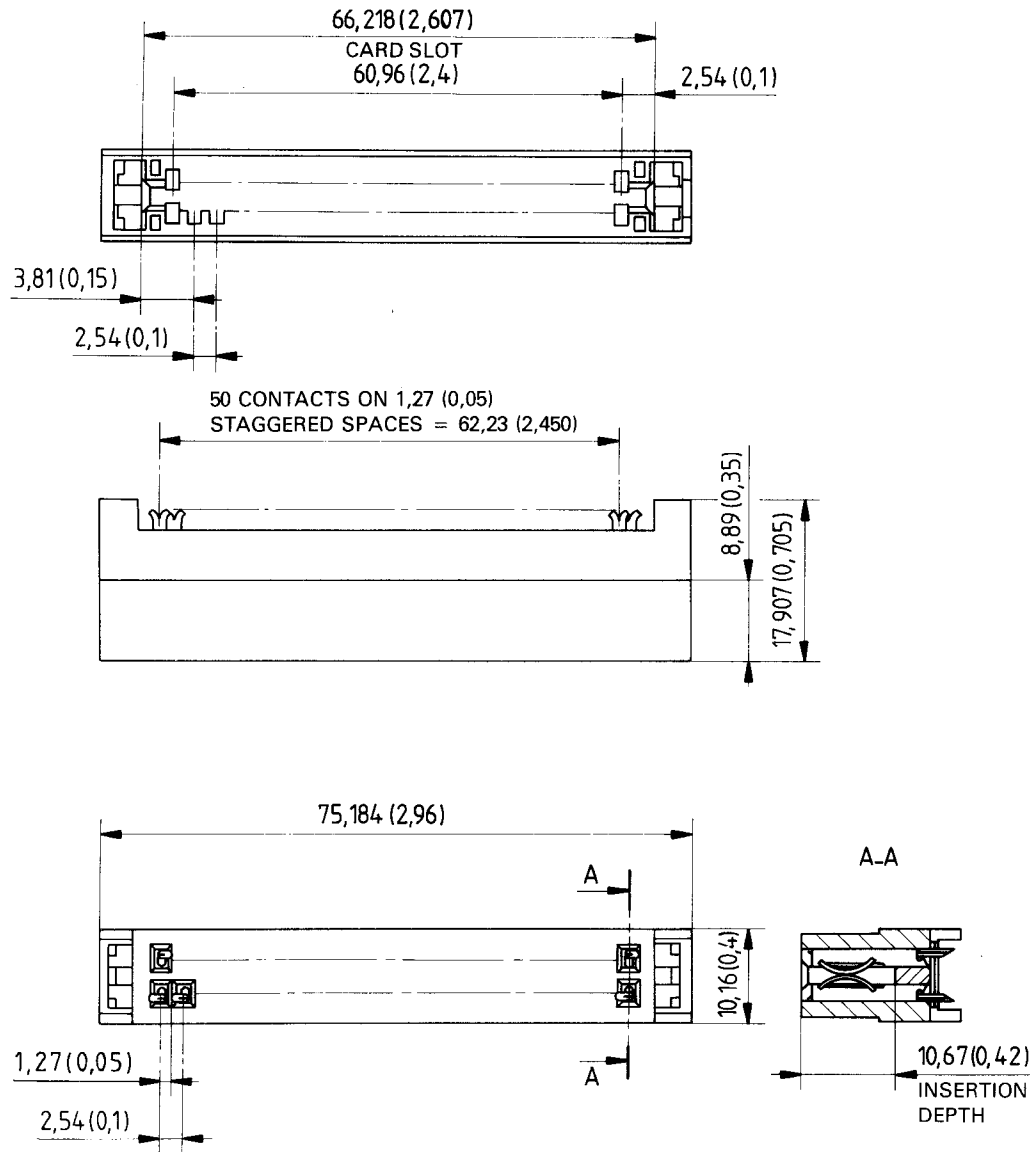

Figure 19 — Signal interface cable connector for 200 mm (8 in) drive

Dimensions in millimetres (inches)

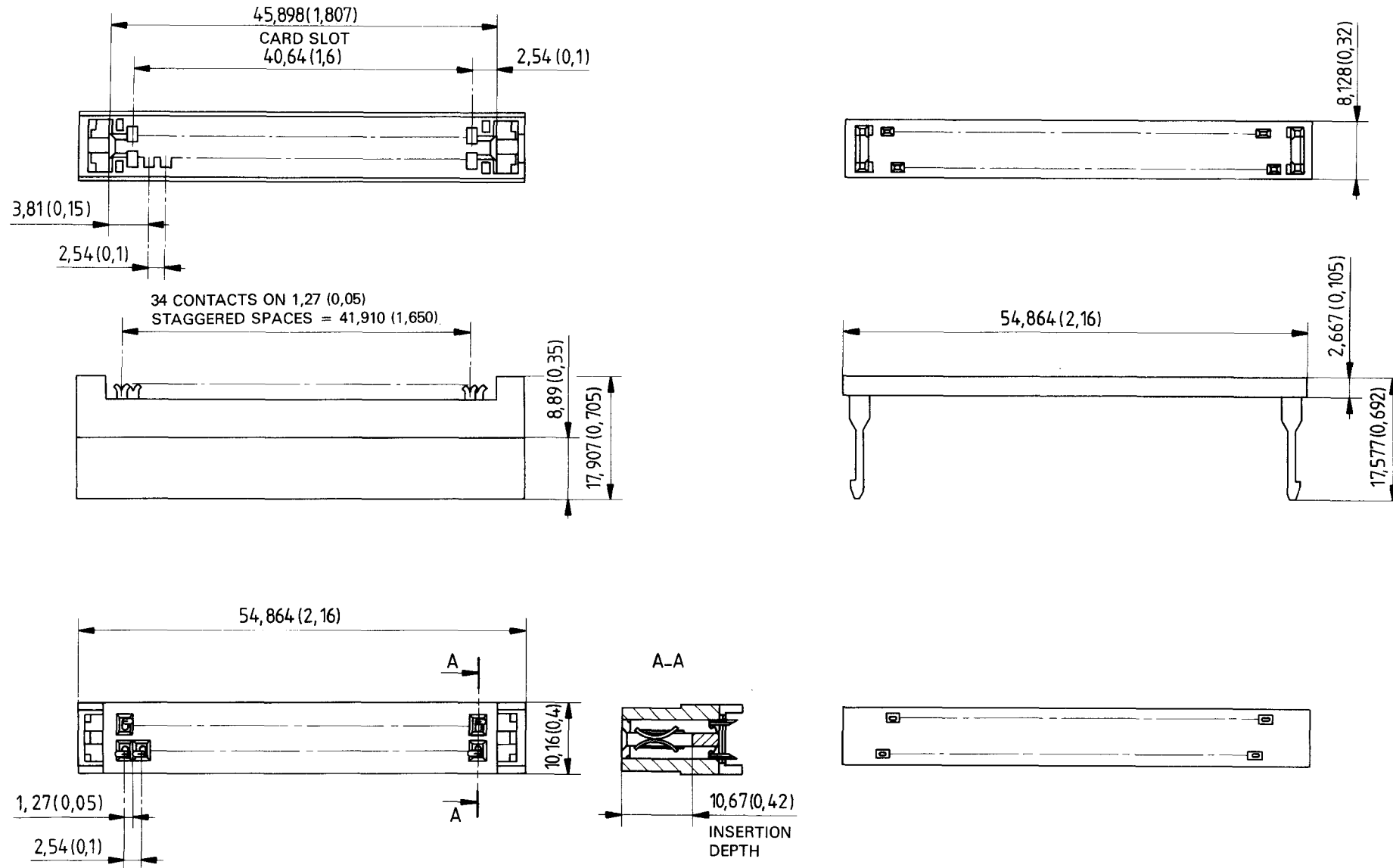

Figure 20 — Signal interface cable connector for 130 mm (5,25 in) drive

UDC 681.327.63'23

Descriptors : data processing, information interchange, data recording devices, flexible disks, interfaces, specifications.

Price based on 17 pages
