**7/24 taper spindle noses for automatic
tool changers —**

Part 2:
**Dimensions and designation of spindle
noses of forms J and JF**

*Nez de broches à conicité 7/24 pour changement automatique
d'outils —*

Partie 2: Dimensions et désignation des nez de broches de formes J et JF



PDF disclaimer

This PDF file may contain embedded typefaces. In accordance with Adobe's licensing policy, this file may be printed or viewed but shall not be edited unless the typefaces which are embedded are licensed to and installed on the computer performing the editing. In downloading this file, parties accept therein the responsibility of not infringing Adobe's licensing policy. The ISO Central Secretariat accepts no liability in this area.

Adobe is a trademark of Adobe Systems Incorporated.

Details of the software products used to create this PDF file can be found in the General Info relative to the file; the PDF-creation parameters were optimized for printing. Every care has been taken to ensure that the file is suitable for use by ISO member bodies. In the unlikely event that a problem relating to it is found, please inform the Central Secretariat at the address given below.



COPYRIGHT PROTECTED DOCUMENT

© ISO 2010

All rights reserved. Unless otherwise specified, no part of this publication may be reproduced or utilized in any form or by any means, electronic or mechanical, including photocopying and microfilm, without permission in writing from either ISO at the address below or ISO's member body in the country of the requester.

ISO copyright office
Case postale 56 • CH-1211 Geneva 20
Tel. + 41 22 749 01 11
Fax + 41 22 749 09 47
E-mail copyright@iso.org
Web www.iso.org

Published in Switzerland

Foreword

ISO (the International Organization for Standardization) is a worldwide federation of national standards bodies (ISO member bodies). The work of preparing International Standards is normally carried out through ISO technical committees. Each member body interested in a subject for which a technical committee has been established has the right to be represented on that committee. International organizations, governmental and non-governmental, in liaison with ISO, also take part in the work. ISO collaborates closely with the International Electrotechnical Commission (IEC) on all matters of electrotechnical standardization.

International Standards are drafted in accordance with the rules given in the ISO/IEC Directives, Part 2.

The main task of technical committees is to prepare International Standards. Draft International Standards adopted by the technical committees are circulated to the member bodies for voting. Publication as an International Standard requires approval by at least 75 % of the member bodies casting a vote.

Attention is drawn to the possibility that some of the elements of this document may be the subject of patent rights. ISO shall not be held responsible for identifying any or all such patent rights.

ISO 9270-2 was prepared by Technical Committee ISO/TC 29, *Small tools*.

This first edition, together with ISO 9270-1, cancels and replaces (ISO 9270:1992), which has been technically revised to take into account the new tool shanks with 7/24 taper for automatic tool changers defined in ISO 7388-2.

ISO 9270 consists of the following parts, under the general title *7/24 taper spindle noses for automatic tool changers*:

- *Part 1: Dimensions and designation of spindle noses of forms S and SF*
- *Part 2: Dimensions and designation of spindle noses of forms J and JF*

7/24 taper spindle noses for automatic tool changers —

Part 2:

Dimensions and designation of spindle noses of forms J and JF

1 Scope

This part of ISO 9270 specifies the dimensions and tolerances of 7/24 taper spindle noses with tenons for automatic tool changers, intended for use with the corresponding tool shanks of forms J, JD and JF according to ISO 7388-2.

2 Normative references

The following referenced documents are indispensable for the application of this document. For dated references, only the edition cited applies. For undated references, the latest edition of the referenced document (including any amendments) applies.

ISO 68-1, *ISO general purpose screw threads — Basic profile — Part 1: Metric screw threads*

ISO 273, *Fasteners — Clearance holes for bolts and screws*

ISO 898-1, *Mechanical properties of fasteners made of carbon steel and alloy steel — Part 1: Bolts, screws and studs with specified property classes — Coarse thread and fine pitch thread*

ISO 965-2, *ISO general purpose metric screw threads — Tolerances — Part 2: Limits of sizes for general purpose external and internal screw threads — Medium quality*

ISO 2768-1:1989, *General tolerances — Part 1: Tolerances for linear and angular dimensions without individual tolerance indications*

ISO 2768-2:1989, *General tolerances — Part 2: Geometrical tolerances for features without individual tolerance indications*

ISO 4762, *Hexagon socket head cap screws*

ISO 8015, *Geometrical product specifications (GPS) — Fundamentals — Concepts, principles and rules*

3 Dimensions

3.1 General

All dimensions and tolerances are given in millimetres; tolerancing is in accordance with ISO 8015. Non-specified tolerances shall be of tolerance class “m” in accordance with ISO 2768-1 and of class “K” in accordance with ISO 2768-2.

3.2 7/24 taper spindle noses of form J for tool shanks of forms J and JD

The dimensions of 7/24 taper spindle noses for tool shanks of forms J and JD shall be in accordance with the dimensions shown in Figure 1 and given in Table 1.

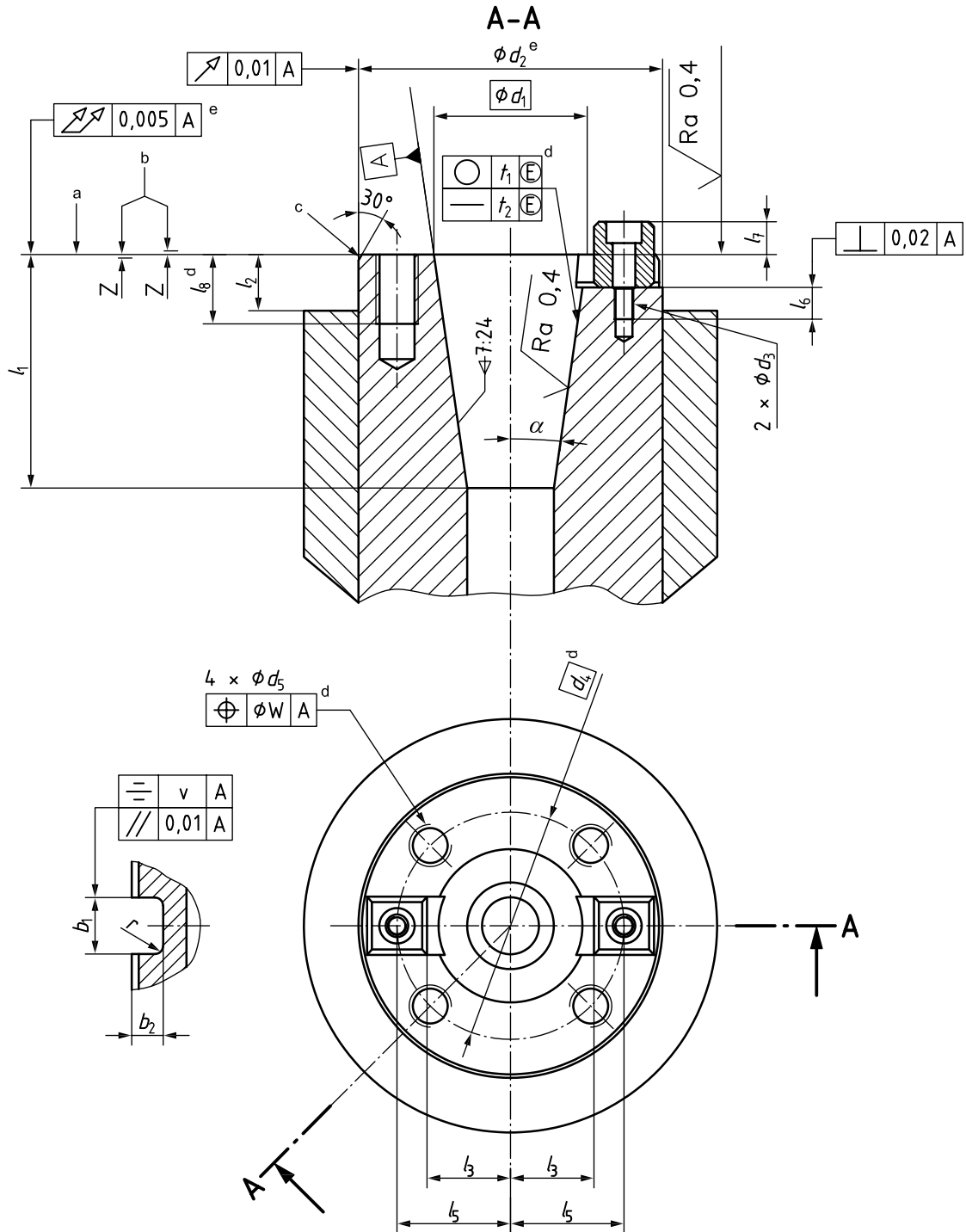

- a Gauge plane.
- b Taper front face positioning tolerance.
- c Chamfer or radius.
- d Optional.
- e Not convex.

Figure 1 — 7/24 taper spindle noses of form J for tool shanks of forms J and JD

Table 1 — 7/24 taper spindle noses of form J for tool shanks of forms J and JD

Shank No.		30	40	45	50	60
Taper	d_1^a	31,75	44,45	57,15	69,85	107,95
	l_1	47,4	64,4	81,8	100,8	160,8
	tol. l_1	0 -9,5	0 -12,9	0 -16,4	0 -20,2	0 -32,2
	z_{\max}	0,2				
	α	8°17'50"				
	tol. α	0 -8,0"	0 -6,5"		0 -5,0"	0 -4,0"
End face part	d_2^b	69,832	88,882	101,6	128,57	180
	l_2^b	12,5	16			19
Tenon slot	b_1^c M6	15,9		19	25,4	
	$b_2^{+0,5}_0$	8		9,5	12,5	
	d_3^d	M6		M8	M12	
	l_3	16,5	23	29,7	36	61
	$l_5 \pm 0,2$	25	33	39,7	49,5	74,5
	l_6	9		12	18	
	l_7^e	8		9,5	12,5	
	$r^{0}_{-0,5}{}^f$	1,6			2	
	t_1	0,001		0,002	0,003	
	t_2	0,002		0,003	0,004	
	v	0,06			0,08	
<p>^a d_1 is the basic diameter contained in the gauge plane.</p> <p>^b Preferred values.</p> <p>^c b_1 is the dimension of the tenon assembly in the slot: fit, M6-h5.</p> <p>^d The screw thread shall be in accordance with ISO 68-1, and its accuracy shall be 6H as specified in ISO 965-2.</p> <p>^e For information.</p> <p>^f Recess may be allowed to be provided.</p>						

3.3 7/24 taper spindle noses of form JF for tool shank of form JF

In addition to spindle nose form J, it is possible to add two holes in the spindle nose face for inner coolant supply, the dimensions of which shall be in accordance with the dimensions shown in Figure 2 and given in Table 2. This form is designated JF.

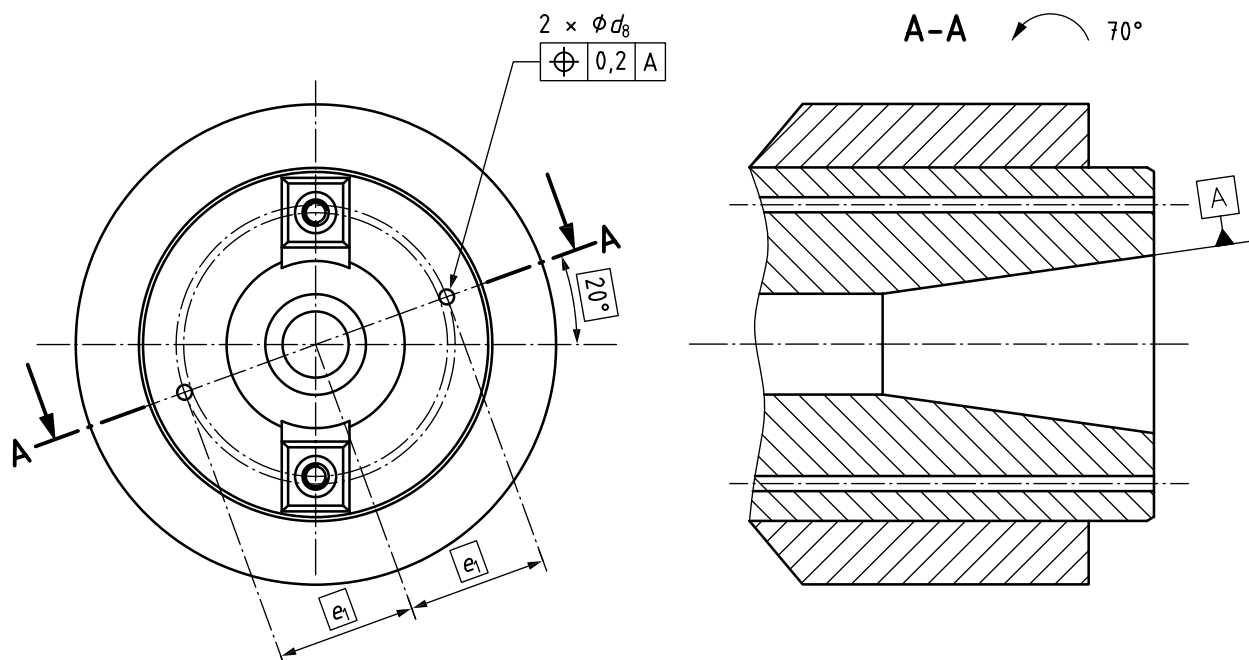

Figure 2 — 7/24 taper spindle noses of form JF for tool shank of form JF

Table 2 — Supplementary dimensions of 7/24 taper spindle noses of form JF for tool shank of form JF

Shank No.	30	40	45	50	60
$d_{8,max}$	2,5	5	6	7,5	10
e_1	20	27	35	42	66

3.4 Dimensions of tenon

The dimensions of tenon shall be in accordance with Figure 3 and Table 3.

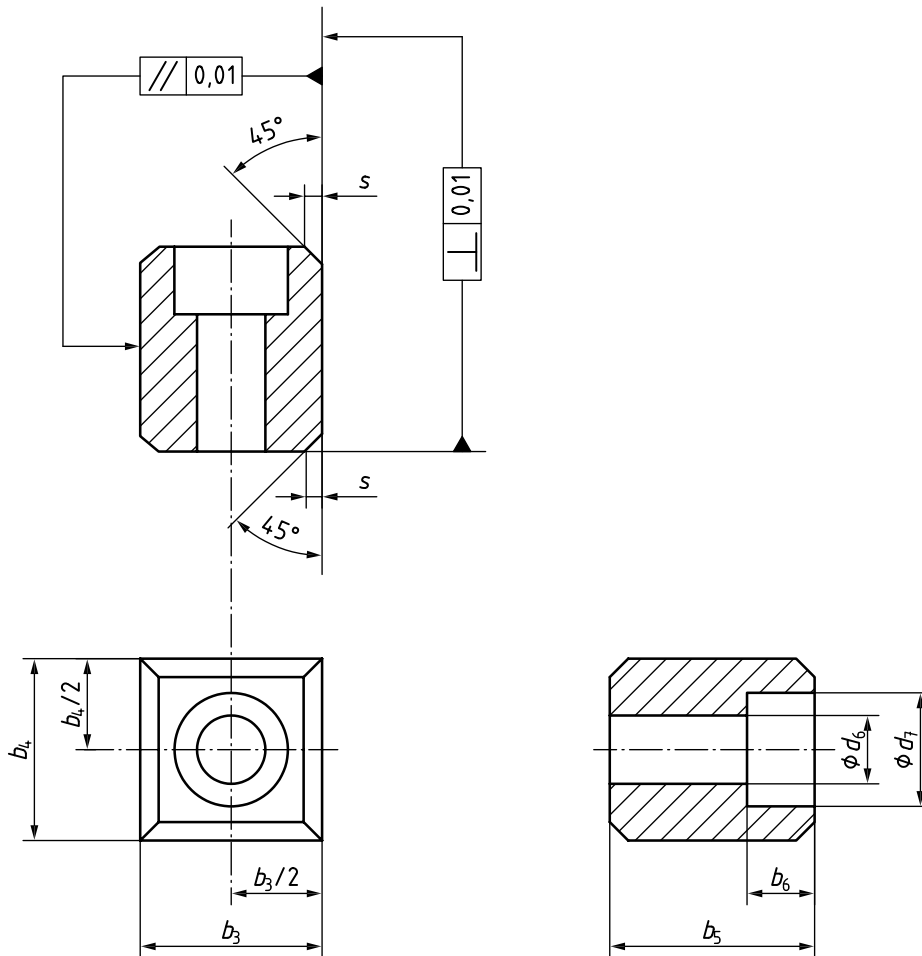

Figure 3 — Tenon dimensions for spindle noses of forms J and JF

Table 3 — Tenon dimensions for spindle noses of forms J and JF

Shank No.	30	40	45	50	60
b_3^a h5	15,9		19	25,4	
$b_{4,max}$	16,5	19,5		26,5	
$b_{5,max}$	16		19	25	
b_6	7		9	13	
d_6^b	6,4		8,4	13	
d_7	10,4		13,4	19	
s_{min}	1,6			2	
Fixing screw ^c	M6 × 15		M8 × 20	M12 × 25	

^a b_3 is the dimension of tenon assembly in the slot: fit, M6-h5.
^b d_6 shall be in accordance with the fine series defined in ISO 273.
^c Fixing screw conforms with both ISO 898-1, class 8.8, and ISO 4762.

4 Materials

7/24 taper spindle noses shall be heat treated with considerations for strength and hardness. Toughness and wear requirements shall be taken into account.

5 Designation

A spindle nose in accordance with this part of ISO 9270 shall be designed by:

- a) "Spindle nose";
- b) the reference to this part of ISO 9270, i.e. ISO 9270-2;
- c) a hyphen;
- d) the form J or JF;
- e) the size.

EXAMPLE Designation of a spindle nose in accordance with ISO 9270-2, form J for tool shank N°40

Spindle nose ISO 9270-2 – J40

Bibliography

- [1] ISO 1101, *Geometrical Product Specifications (GPS) — Geometrical tolerancing — Tolerances of form, orientation, location and run-out*
- [2] ISO 7388-1, *Tool shanks with 7/24 taper for automatic tool changers — Part 1: Dimensions and designation of shanks of forms A, AD, AF, U, UD and UF*
- [3] ISO 7388-2, *Tool shanks with 7/24 taper for automatic tool changers — Part 2: Dimensions and designation of shanks of forms J, JD and JF*
- [4] ISO 7388-3, *Tool shanks with 7/24 taper for automatic tool changers — Part 3: Retention knobs for shanks of forms AC, AD, AF, UC, UD, UF, JD and JF*

11/11/2023 10:00 AM

ICS 25.060.20

Price based on 8 pages