

---

---

**Ergonomics of human-system  
interaction —**

**Part 910:  
Framework for tactile and haptic  
interaction**

*Ergonomie de l'interaction homme-système —*

*Partie 910: Cadre pour les interactions tactiles et haptiques*

Reference number ISO 9241-910:2011(E)



Reference number  
ISO 9241-910:2011(E)

© ISO 2011



**COPYRIGHT PROTECTED DOCUMENT**

© ISO 2011

All rights reserved. Unless otherwise specified, no part of this publication may be reproduced or utilized in any form or by any means, electronic or mechanical, including photocopying and microfilm, without permission in writing from either ISO at the address below or ISO's member body in the country of the requester.

ISO copyright office  
Case postale 56 • CH-1211 Geneva 20  
Tel. + 41 22 749 01 11  
Fax + 41 22 749 09 47  
E-mail [copyright@iso.org](mailto:copyright@iso.org)  
Web [www.iso.org](http://www.iso.org)

Published in Switzerland

# Contents

Page

Foreword .....	v
Introduction.....	vii
1 Scope .....	1
2 Terms and definitions .....	1
3 Introduction to haptics.....	4
4 Human haptic exploration .....	5
4.1 Importance of the haptic sense .....	5
4.2 Haptics and vision.....	5
4.3 Manual exploration of objects.....	6
4.4 Training in exploratory procedures.....	6
4.5 The problem of getting an overview of a scene with haptics .....	7
4.6 Minimum physical stimulation: absolute thresholds .....	7
4.7 Minimum differences needed for perception.....	7
4.8 Perception of geometric properties of objects.....	7
4.9 Perception of weight .....	7
4.10 Perception of material properties .....	8
4.11 Number and size of contact surfaces in tactile/haptic devices .....	8
4.12 Summary .....	8
5 When to use tactile/haptic interactions.....	9
5.1 General .....	9
5.2 Accessibility.....	9
5.3 Desktop interactions .....	10
5.4 Mobile interactions .....	10
5.5 Robotics .....	10
5.6 Medical.....	11
5.7 Gaming .....	11
5.8 Art and creativity .....	12
5.9 Multimodal applications and simulators.....	12
6 Designing tactile/haptic interactions.....	13
6.1 Design guidelines for tactile/haptic interaction .....	13
6.2 Designing tactile/haptic space.....	14
6.3 Addressability and resolution in tactile/haptic interaction .....	15
7 User-initiated interactive task primitives .....	17
7.1 General .....	17
7.2 Searching .....	17
7.3 Overviewing .....	17
7.4 Navigating .....	18
7.5 Targeting .....	18
7.6 Selection.....	18
7.7 Manipulation .....	19
8 Tactile/haptic interaction elements .....	20
8.1 General .....	20
8.2 Tactile/haptic functional effects.....	20
8.3 Tactile/haptic properties of objects.....	21
8.4 Control elements .....	23
8.5 Using multi-point-contact interfaces.....	23
8.6 Combining elements and effects .....	24
8.7 Distinguishability.....	24

<b>9</b>	<b>The range of tactile/haptic interface devices .....</b>	<b>24</b>
<b>9.1</b>	<b>General.....</b>	<b>24</b>
<b>9.2</b>	<b>Selection criteria .....</b>	<b>24</b>
<b>Annex A</b>	<b>(informative) Tactile devices.....</b>	<b>35</b>
<b>Annex B</b>	<b>(informative) Tactile/haptic devices that provide force feedback.....</b>	<b>39</b>
<b>Annex C</b>	<b>(informative) Physiology of haptics .....</b>	<b>44</b>
<b>Bibliography</b>	<b>.....</b>	<b>50</b>

.....

## Foreword

ISO (the International Organization for Standardization) is a worldwide federation of national standards bodies (ISO member bodies). The work of preparing International Standards is normally carried out through ISO technical committees. Each member body interested in a subject for which a technical committee has been established has the right to be represented on that committee. International organizations, governmental and non-governmental, in liaison with ISO, also take part in the work. ISO collaborates closely with the International Electrotechnical Commission (IEC) on all matters of electrotechnical standardization.

International Standards are drafted in accordance with the rules given in the ISO/IEC Directives, Part 2.

The main task of technical committees is to prepare International Standards. Draft International Standards adopted by the technical committees are circulated to the member bodies for voting. Publication as an International Standard requires approval by at least 75 % of the member bodies casting a vote.

Attention is drawn to the possibility that some of the elements of this document may be the subject of patent rights. ISO shall not be held responsible for identifying any or all such patent rights.

ISO 9241-910 was prepared by Technical Committee ISO/TC 159, *Ergonomics*, Subcommittee SC 4, *Ergonomics of human-system interaction*.

ISO 9241 consists of the following parts, under the general title *Ergonomic requirements for office work with visual display terminals (VDTs)*:

- *Part 1: General introduction*
- *Part 2: Guidance on task requirements*
- *Part 4: Keyboard requirements*
- *Part 5: Workstation layout and postural requirements*
- *Part 6: Guidance on the work environment*
- *Part 9: Requirements for non-keyboard input devices*
- *Part 11: Guidance on usability*
- *Part 12: Presentation of information*
- *Part 13: User guidance*
- *Part 14: Menu dialogues*
- *Part 15: Command dialogues*
- *Part 16: Direct manipulation dialogues*
- *Part 17: Form filling dialogues*

ISO 9241 also consists of the following parts, under the general title *Ergonomics of human-system interaction*:

- *Part 20: Accessibility guidelines for information/communication technology (ICT) equipment and services*
- *Part 100: Introduction to standards related to software ergonomics [Technical Report]*
- *Part 110: Dialogue principles*

## ISO 9241-910:2011(E)

- *Part 129: Guidance on software individualization*
- *Part 143: Forms*
- *Part 151: Guidance on World Wide Web user interfaces*
- *Part 171: Guidance on software accessibility*
- *Part 210: Human-centred design for interactive systems*
- *Part 300: Introduction to electronic visual display requirements*
- *Part 302: Terminology for electronic visual displays*
- *Part 303: Requirements for electronic visual displays*
- *Part 304: User performance test methods for electronic visual displays*
- *Part 305: Optical laboratory test methods for electronic visual displays*
- *Part 306: Field assessment methods for electronic visual displays*
- *Part 307: Analysis and compliance test methods for electronic visual displays*
- *Part 308: Surface-conduction electron-emitter displays (SED) [Technical Report]*
- *Part 309: Organic light-emitting diode (OLED) displays [Technical Report]*
- *Part 310: Visibility, aesthetics and ergonomics of pixel defects [Technical Report]*
- *Part 400: Principles and requirements for physical input devices*
- *Part 410: Design criteria for physical input devices*
- *Part 411: Evaluation methods for the design of physical input devices [Technical Specification]*
- *Part 420: Selection of physical input devices*
- *Part 910: Framework for tactile and haptic interaction*
- *Part 920: Guidance on tactile and haptic interactions*

The following parts are under preparation:

- *Part 154: Interactive voice response (IVR) applications*

Human-centred design and evaluation methods, optical characteristics of autostereoscopic displays, and requirements, analysis and compliance test methods for the reduction of photosensitive seizures are to form the subjects of future parts 230, 331 and 391.

## Introduction

Tactile and haptic interactions are becoming increasingly important as candidate interaction modalities in computer systems such as special-purpose computing environments (e.g. simulation) and assistive technologies.

While considerable research exists, it involves a wide diversity of terms, meanings of terms, viewpoints, software and hardware objects, attributes and interactions. This diversity can lead to serious ergonomic difficulties for both developers and users of tactile/haptic interactions.

This part of ISO 9241 provides a common set of terms, definitions and descriptions for the various concepts central to the design and use of tactile/haptic interactions. It includes basic guidance (including references to related standards) in the design of tactile/haptic interactions. It also provides an overview of the range of tactile/haptic applications, objects, attributes and interactions.





# Ergonomics of human-system interaction —

## Part 910: Framework for tactile and haptic interaction

### 1 Scope

This part of ISO 9241 provides a framework for understanding and communicating various aspects of tactile/haptic interaction. It defines terms, describes structures and models, and gives explanations related to the other parts of the ISO 9241 “900” subseries. It also provides guidance on how various forms of interaction can be applied to a variety of user tasks.

It is applicable to all types of interactive systems making use of tactile/haptic devices and interactions.

It does not address purely kinaesthetic interactions, such as gestures, although it might be useful for understanding such interactions.

### 2 Terms and definitions

For the purposes of this document, the following terms and definitions apply.

#### 2.1

**haptics**, noun

sensory and/or motor activity based in the skin, muscles, joints and tendons

NOTE Haptics consists of two parts: touch and kinaesthesia.

#### 2.2

**haptic**, adj

appertaining to haptics

NOTE While there is no difference between *haptic* and *tactile* in most dictionary definitions, in the area of haptics, researchers and developers use *haptic* to include all haptic sensations, while *tactile* is limited to mechanical stimulation of the skin. In ISO 9241, the word *haptic* covers all touch sensations and *tactile* is used in a more specific manner. Also, both terms can be used together to assist in searches.

#### 2.3

**touch**

sense based on receptors in the skin

NOTE Cutaneous receptors are used for the perception of touch.

#### 2.4

**cutaneous**

belonging to the skin

NOTE Cutaneous receptors respond to mechanical stimulation and temperature changes.

**2.5**

**tactile**

appertaining to touch

**2.6**

**vibrotactile**

vibration-based stimulation of the skin

EXAMPLE A cellular phone uses vibrotactile stimulation to alert the user.

**2.7**

**kinaesthesia**, noun

sense and motor activity based in the muscles, joints and tendons

NOTE 1 Kinaesthesia includes both input and output.

NOTE 2 Receptors in the muscles, joints and tendons are used for the perception of kinaesthesia.

NOTE 3 Muscles, tendons and joints are used for motor activity.

**2.8**

**kinaesthetic**, adj

appertaining to kinaesthesia

NOTE 1 Types of kinaesthetic sensation arise from force, movement, position, displacement and joint angle.

NOTE 2 Types of kinaesthetic actions include movement, exertion of force and torque, and achievement of position, displacement and joint angle.

NOTE 3 *Proprioception* refers to the sense of one's own body position and movement. This term is often used interchangeably with kinaesthesia, although the latter is concerned more with motion. The sense of balance, for example, might fall more under proprioception than kinaesthesia.

**2.9**

**force feedback**

force presented to and detected by a user

NOTE Although this does not necessarily involve *feedback*, the term "force feedback" is commonly used in this context.

**2.10**

**perceptual illusion**

perception that does not correspond to a physical measurement of the stimulus source

**2.11**

**sensory adaptation**

change over time in the responsiveness of the sensory system to a constant stimulus

**2.12**

**(tactile/haptic) spatial masking**

effect that occurs when a distracter stimulus, which is close to the target stimulus, degrades the perception of the target

**2.13**

**(tactile/haptic) temporal masking**

effect that occurs when a distracter stimulus, which is presented immediately preceding or following a target stimulus, degrades the perception of the target

**2.14****tactile/haptic object**

component of an interactive system that a user can interact with haptically

**2.15****(tactile/haptic) user interface element**

entity of a user interface that is presented in a tactile/haptic form

**2.16****(tactile/haptic) task primitive**

fundamental action of a user for carrying out the tasks for which the device is designed

**2.17****tactile label**

label of a user interface element that is presented in the tactile/haptic modality

**2.18****tactile map**

map that is presented in the tactile/haptic modality with input functions

NOTE 1 The input functions include finger touching, lifting off, or moving across the map for producing position and selection.

NOTE 2 Tactile maps are often used to help blind people navigate.

**2.19****stiffness****hardness****elasticity**

haptic response to interactions involving force normal to a virtual object's surface

NOTE 1 "Stiffness" is often known as "hardness" when applied to rigid material.

NOTE 2 "Stiffness" is often known as "elasticity" when applied to soft material.

NOTE 3 *Maximum stiffness* is the highest equivalent spring constant of a virtual surface that can be provided by the device without instability.

**2.20****burst**

intentionally short tactile/haptic stimulation

NOTE A burst typically lasts between 10 ms and 1 s.

**2.21****probe**

object in a virtual space that is under the control of a tactile/haptic device

**2.22****spatial resolution**

degree to which the physical output from a user can be utilized by the device

**2.23****addressability**

ability to address a specific point or set of points in a workspace

### 3 Introduction to haptics

The science of haptics and the creation of tactile/haptic devices depend on knowledge of the human body, especially on its capability to sense both touch to the skin and kinaesthetic activity in the limbs and body joints.

Figure 1 shows the relationship between the components that make up the field of haptics. The field is divided between the study of touch and the study of kinaesthesia.

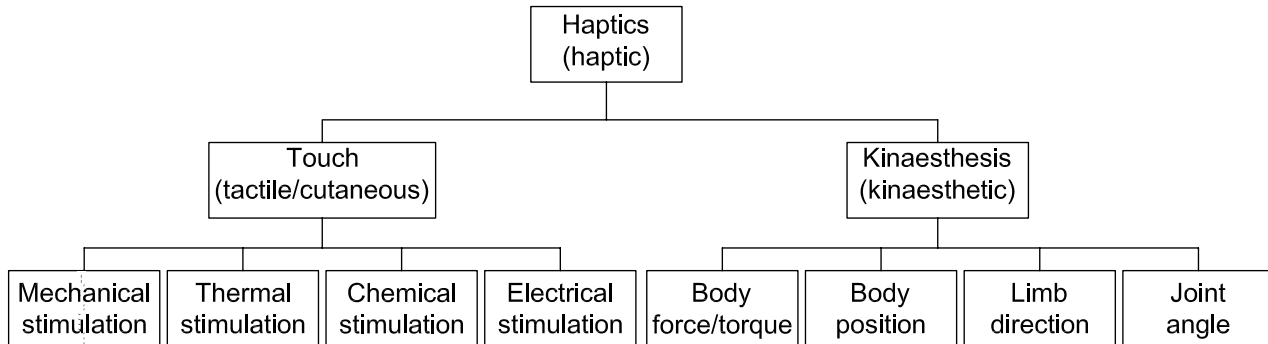

**Figure 1 — The components of haptics**

“Touch” includes such diverse stimuli as mechanical, thermal, chemical and electrical stimulation to the skin. Specific nerves and sensing organs in the skin respond to these stimuli with different spatial and temporal resolutions.

The *kinaesthetic* sense can be matched by kinaesthetic activity by which a user exerts force or torque on an object external to the active body part. With the combination of kinaesthetic sensing and kinaesthetic activity, the user can detect the force and torque with which the body resists the force and torque of a tactile/haptic device. Likewise, by imposing a measured force and torque on an object, the user can determine macro properties such as its inertia.

Kinaesthesia is thereby bi-directional, both sensing the environment and actively manipulating it in a two-way exchange of information and action.

NOTE 1 Active touch involves kinaesthesia, passive touch does not. Active and passive touch are often very useful concepts by which to distinguish interactions. In interactions, it is not always possible to identify the two concepts with particular devices. Depending on the task, one form of touch might be superior to another.

NOTE 2 Interaction with tactile/haptic devices might use different combinations of these haptic components at multiple points of contact.

NOTE 3 See Annex C for the details of the physiology of human haptics.

## 4 Human haptic exploration

### 4.1 Importance of the haptic sense

Haptics is of great importance for human life, much more so than is generally recognized. For instance, when you are searching for an object in your pocket or bag without the help of vision, haptics is engaged. When you identify the object you wanted, grasp it with suitable force and take it out, your actions are based on haptics. This sense can identify common objects quite efficiently, with near perfect discrimination within a few seconds, especially when the observer has some expectation about the options.

By palpating the surface of a body, a physician can obtain information about the conditions of organs under the skin and fat layers, conditions that cannot be perceived visually.

The haptic sense can also allow remote touching, as when a distant object is probed with a tool. For example, a visually impaired person may use a cane to perceive the properties of the ground at the tip of the cane.

The hands, in particular, have had an enormous importance in the biological and cultural development of human beings in their contact with the environment. They are at the same time useful for both perception and action in a continuous interaction with the environment. A hand has an impressive ability to adapt to many different kinds of manipulation tasks, from very small ones requiring high precision to large ones where large forces are needed. The actions are at all times guided by haptic feedback.

However, haptics within computer applications is new compared to visual and auditory interactions and is still relatively limited. Present-day tactile/haptic devices still need much development before they can fully utilize the capacity of the haptic sense.

Touch is also often used to confirm information we gain about the reality of the world.

### 4.2 Haptics and vision

#### 4.2.1 Similarities and differences between haptics and vision

Haptics has many properties in common with vision. It can be used to locate objects in relation to the observer in near space (but only within arm's reach unless a tool is used), to find edges separating surfaces and to perceive the size and form of objects (that are not too large to be explored by a person). In perceiving texture, haptics not only matches vision but is, in many conditions, superior to it.

In some tasks, haptics lags considerably behind vision or cannot perform the task at all. For example, it is unable to be used to get an overview of a scene, perceive 3D space beyond arm's reach, perceive colours, or perceive edges in a 2D picture without embossment.

In other tasks, haptics is superior to vision. With haptics, we can directly judge the weight of objects, as well as their hardness and temperature. Vision can to some extent perceive such object properties, but only by observing another person's actions.

#### 4.2.2 Co-location of visual and haptic space

In the real world, objects are usually perceived to occupy the same location visually and tactually but, in virtual worlds, this is not necessarily the case. The visual object can be located on a screen, while the haptic object has another location — presented on a tactile/haptic device by the side of the keyboard, for example. Advantages of co-location have been shown for object targeting and for perception of form. Informally, it has also been found that performing tasks such as finding knobs and regaining contact with lost virtual objects was facilitated under co-location conditions.

Combining the visual and haptic modalities can enrich a user's perception of a scene. The visual sense might dominate at first, allowing a quick overview of a scene and identification of objects in the scene. But a tactile display can allow a more rapid judgment of the texture of an object. The relative distances of objects can be

perceived haptically within personal space, reinforcing visual judgment of the distances. Then object properties such as mass and deformability can be confirmed only through the haptic sense.

**EXAMPLE** A pianist, when sight-reading music, relies on haptics to locate the position of the notes on the keyboard, but, while playing from memory, utilizes visual and haptic modalities together, making the performance more relaxed and thus enriching it.

#### 4.2.3 Implications for haptic displays

The differences between vision and haptics make it hazardous to simply render copies of visual objects in order to present them haptically. Such copying might succeed in simple cases, but problems will often occur in more complex ones. It is important that the creation of effective haptic scenes involves the haptic consideration of their properties. An effective visual rendering of a scene is no guarantee that the same scene can be successfully rendered in a haptic sense.

Advantage can be taken of the ability of the body to quickly coordinate cross-modal maps of its environment. Both visual and tactile senses can work together to allow a more rapid location of a stimulus than is possible with either modality alone.

Other prediction experiments have shown that dynamic tactile information can be used to reorient visual attention, and that dynamic visual information can be used to accurately reorient tactile information.

#### 4.3 Manual exploration of objects

The movements of an observer during haptic exploration of the environment are typically not random, but are specifically directed to acquire desired information. These movement patterns, called exploratory procedures, consist of a number of basic procedures such as

- a) lateral motion for perceiving texture,
- b) pressure for perceiving hardness,
- c) unsupported holding for perceiving weight,
- d) enclosure (enclosing an object in a hand or both hands) for perceiving global shape and volume, and
- e) contour-following for perceiving global shape and exact shape.

Tactile/haptic devices might limit the exploratory procedures that are available to a user, significantly decreasing exploratory performance. Special training in the movements useful for specific displays can partially compensate for this lack.

#### 4.4 Training in exploratory procedures

Texture is less of a problem for the perception of objects than is shape. This might be because the exploratory procedure for texture is much simpler than that for shape. When exploring for texture, the user might make arbitrary movements over the object's surface, while exploring for shape requires quite specific movements. However, training in appropriate exploratory procedures for a given shape can result in much better performance. This is important to consider when evaluating haptic displays, as there is a risk of under-estimating the usefulness of a device if the users have insufficient experience with the device.

#### 4.5 The problem of getting an overview of a scene with haptics

One of the most difficult problems with haptics in many practical contexts is gaining an overview of a scene. In vision, this overview is carried out almost instantaneously. There are situations where a “haptic glance” (short contact with the object) can provide something of the same quality as vision, especially when the observer has hypotheses about the object in question. However, it is usually a laborious and time-consuming task to identify objects in more complex conditions using haptics alone. It is often useful to enhance haptics with auditory or visual information. For instance, there could be verbal or textual information about the object, or instructions about how to explore the scene.

#### 4.6 Minimum physical stimulation: absolute thresholds

Haptic perception is based on many kinds of sensors in the skin, as well as in the muscles, tendons and joints. A minimum of physical stimulation, called *absolute threshold*, is needed to get the sensors to react and send messages providing experience for the observer. Many physical events can stimulate the skin, from a light brush stroke to pressure from points, edges, corners and curvature. They might cause skin motion, skin stretch or vibration, and require different amounts of energy to be perceived. The spatial acuity of the skin has been found to be around 1 mm. In general, the hand is not as good in spatial discrimination as the eye but is better than the ear. With regards to temporal discrimination, the hand is better than the eye, but poorer at it than the ear.

The skin is a large sense organ and its different parts vary in sensitivity. The fingertips are among the most sensitive parts and best suited to exploring the environment. The lips and the mouth are also very sensitive. This particular sensitivity has recently been utilized by the development of a tactile/haptic device that is to be placed in the mouth. Less sensitive parts of the body, such as the stomach and back, have also been used as locations for tactile/haptic devices, but spatial resolution in these locations is much lower than in the hands and mouth.

It is important to consider the age of potential users of tactile/haptic devices, since there is a considerable decline in haptic sensitivity with age.

#### 4.7 Minimum differences needed for perception

A minimum of physical difference between two stimulations is necessary for an observer to experience the difference. This is called the difference threshold or “just noticeable difference” (JND).

**EXAMPLE 1** In discerning the difference in the direction of two forces, the difference is at least 33° in order for the difference to be detected.

**EXAMPLE 2** In comparing objects by squeezing them, the resistance force in one is about 7 % larger than in the other in order for the difference to be detected.

#### 4.8 Perception of geometric properties of objects

Object properties can be divided into geometric and material properties. Size and shape are geometric properties commonly used for the identification of objects. In the real world, the exploratory procedures of enclosure and contour-following are used to gain this information. These procedures are not always possible with current haptic displays. Perception of shape is possible with such displays but is less efficient and more time-consuming than in the real world. One key reason for this is that most tactile/haptic devices offer a single point of contact.

#### 4.9 Perception of weight

Haptic perception of weight has been studied since the nineteenth century. Such studies recently took a new direction in considering how people judge weight on the basis of wielding the object to be judged. The stimulation in this case is the resistance to the rotational torque picked up by the haptic system. Properties such as the length of a rod or the form of an object can be judged by wielding the rod or object. The amount of liquid in an opaque container can be judged by haptics alone when the container is shaken.

#### 4.10 Perception of material properties

An object's surface can have many material properties. It can vary from hard to soft, as well as from smooth to rough. The latter property is called *texture*, and depends on the microstructure of the surface — regular or irregular deviations from complete evenness. Microstructure can be contrasted with macrostructure that gives shape. Soft/hard and smooth/rough are the two main perceptual dimensions of haptically perceived objects. Another is sticky/slippery, based on the degree of resistance a surface makes to movements along it. There have been efforts to render thermal properties, but they have so far not been very successful.

In the real world there are complex interactions between the haptic, visual and auditory senses when texture is perceived. Sometimes they complement each other, sometimes they are in conflict, and one can dominate the others. The combined effects of all three aspects have to be taken into account when multisensory rendering is being considered.

Texture is typically perceived when a textured surface is in direct contact with a rubbing finger. But texture can also be perceived in other ways, such as by means of a hand tool — a rigid link between skin and surface. This method can be useful in virtual environments for rendering texture.

In contrast to shape, virtual surface properties are relatively easy to judge by haptics in both real and virtual worlds. In an experiment where the roughness of both real and virtual sandpaper was explored with a stylus, the judgements were very similar. However, there are sometimes problems with rendering complex, realistic haptic textures.

#### 4.11 Number and size of contact surfaces in tactile/haptic devices

When a hand is functioning naturally, there are several contact surfaces, with the tips of several fingers typically on a surface at one time. In many present-day haptic displays, the number of contacts is low and, in most cases, it is just one. The virtual contact surface itself is also, except in a few devices, represented by only a single point. This gives a contact analogue, but not a realistic simulation.

When only one contact area is used, it is not possible to get simultaneous information from several contact areas; only successive information is available.

The use of only one finger means that enclosure cannot be used.

**NOTE** Enclosure is an important exploratory procedure for perceiving global shape in which several fingers grasp an object.

Results from perceptual studies have shown that the lack of spatially-distributed information across the contact points is more important than the actual number of contact points.

#### 4.12 Summary

Even if the haptic sense cannot provide an immediate overview of a space and cannot cover distances out of arm's reach, it has great efficiency in providing information about objects and events in near space. The hands can very competently perform many tasks in real environments. They can judge geometric and material surface properties by specific exploratory procedures. They can determine weight and form by wielding the object and feeling its translational and rotational inertia (as in ascertaining the amount of fluid in a shaken container).

When rendering objects and events for haptic perception, it is important to consider the special properties of the haptic senses. Devices and software currently available provide good analogue clues that allow the partial rendering of haptic scenes. On the other hand, they limit the ways in which the user can perceive a scene by haptic means. Future devices might well make use of more of the haptic sensing modalities available to the human operator.



## 5 When to use tactile/haptic interactions

### 5.1 General

Tactile and haptic devices can be used in many different situations and for many different tasks. For some tasks they are interchangeable, for some they can be used together and for others the nature of the particular type of feedback means that one type is most effective.

Due to their compact size and power requirements, tactile displays offer a discrete, affordable means of providing access to data via the sense of touch. Tactile displays are often small enough to be mounted on other interaction devices such as a mouse, keyboard or games controller, or portable devices such as mobile telephones and personal digital assistants (or even on tactile/haptic devices providing force feedback). Tactile information is widely used within the video gaming community as an inexpensive means of providing touch feedback in handheld games controllers. Tactile sensations are crucial to success in object manipulation, edge detection and texture perception. They are also implicated in more expressive and qualitative contexts such as non-visual communication (e.g. a tap on the shoulder or a caress on the hand), and perceptions of product quality.

Tactile/haptic devices providing force feedback are typically much larger than purely tactile ones and require more power to exert stronger forces. Therefore, they are not usually mobile. They are more commonly focused on simulating real world tasks, e.g. work on surgery simulation and training. Their high fidelity and accuracy means that they can be used to teach subtle touch-based skills, even when these require the simulation of very heavy or dynamic objects.

In some respects it is easier to simulate the larger forces required to interact with objects kinaesthetically rather than the smaller cutaneous ones for tactile feedback, so devices that provide force feedback can often make more-realistic-feeling objects than tactile ones can. The following sections outline some of the major areas of use of tactile and force feedback displays.

### 5.2 Accessibility

Haptic displays can offer an alternative channel through which to present information if other senses are impaired. The traditional use of encodings such as Braille is effective at presenting textual information non-visually, but touch can also be used to present, or enhance, iconic and pictorial data for those whose sight is limited. Alternatively, for someone with hearing problems, touch can be used to present alarms or other messages that might otherwise be given in sound. The process of sensory substitution involves the sensing of stimuli by electronic means, transformation of the stimulus via signal processing and presentation of the transformed stimulus in another sensory modality.

Dynamic, refreshable Braille displays offer flexibility and independence. These can be applied to mobile tactile/haptic devices such as tactile/haptic feedback keypads/keyboards and information display devices for the blind. The most commonly used tactile displays evoke sensations using mechanical perturbations of the skin. This is commonly done by vibrating a small plate pressed against the skin, or via a pin or an array of pins on the fingertip. There are systems which give visually impaired people access to virtual maps via the Web that are based on the printing of maps on a Braille printer and placement on a touch tablet for input.

Tactile/haptic devices can be used to present information to people with visual impairments that make access to material such as graphs, charts or tables difficult. Braille is good for presenting textual information but not good for complex images. Visualization systems, such as line graphs or bar-charts, can be presented as grooves that allow users to explore them to feel the shape of their data. These are very successful and they can present information more effectively than raised paper alternatives, can be dynamic where paper cannot be changed, and can allow users to manipulate and change data themselves, without the need for a sighted helper.

### 5.3 Desktop interactions

Haptic feedback can be used in graphical user interfaces for desktop computers, e.g. using a vibrating mouse. While the effect of vibration on the acquisition of single targets might not significantly reduce targeting time, it can reduce the time the user spends over the target. The addition of tactile feedback (e.g. in the form of a constant 200 Hz vibration when the mouse is over a target) can improve targeting speed for small, discretely located targets. However, when multiple targets are present, tactile feedback can cause confusion and reduce performance as the feedback from different targets interferes with one another.

Force feedback can be used to aid in the targeting of objects on the desktop graphical user interface for those with and without sight. Different parts of the standard interface can be given haptic effects, e.g. window borders can be given ridges to make them easier to drag, or windows can be dragged by pressing down hard on them, as if sliding paper across a desk.

### 5.4 Mobile interactions

Tactile feedback is very effectively used by mobile telephones and pagers. Vibration motors provide notification for incoming calls and messages. The fact that the device can be in a pocket means that visual displays need not be seen. The wide range of auditory environments that the phone can be in means that sometimes sound feedback is inappropriate (e.g. in a library, the ringing sound would be disturbing; in a noisy crowd, it might not be heard at all). Tactile feedback solves many of these problems and is very popular with users.

The use of vibrations can be extended beyond simple alerts and alarms on a phone. Touchscreen phones are now common and have no physical keyboard. Although the keyboards used on touchscreen devices are based on the original physical mobile keyboards, one important feature is lost: the buttons cannot provide the tactile response that physical buttons can when touched or clicked. This results in much poorer typing performance. With the addition of extra tactile feedback, delivered by the internal vibration motor in the phone, performance in pressing the touchscreen buttons can be returned to the level of a real, physical keyboard.

Tactile progress indicators can use tactile pulses to indicate the amount of a task (such as the loading of a web page or the downloading of photos) that is remaining so that the user can look at something else whilst waiting. "Haptic emoticons" can be used to express emotions instead of graphical emoticons such as "☺". These haptic icons can be designed to be triggered by typing the textual equivalent and can then be sent to the vibration motor on the phone.

Tactile feedback can be used to give direction information. A wearable tactile vest can display navigation information, including information on direction, rotation, speed and acceleration. The stimulation of a single actuator at the appropriate location can indicate direction, while a movement across several actuators can signal rotation. Changing the frequency, intensity or duration of the vibrations can indicate an increase/decrease in speed or acceleration. The accuracy of such a display is in the order of 10° — more than sufficient to navigate a helicopter or boat along a predefined route. Tactile feedback can be used in cars for lane departure warnings and other potentially dangerous events. Drivers often respond more rapidly to tactile alerts than to audio or visual ones.

### 5.5 Robotics

Telerobotics, or human-directed robotics, is an established application area for tactile/haptic devices. Systems can allow an operator to handle radioactive material in a nuclear "hot box". The operator can look through protective glass while handling liquids in vials and using forceps, all the while manipulating handle grips on arms slung from the ceiling.

Electromechanical tactile/haptic devices can be used as part of control stations to drive robots. Adaptation of full tactile/haptic device feedback in this field is limited by the possibility of instability. Such instability can cause the robot to vibrate, damaging items in its workspace. Precautions are taken to ensure the safety of any robot system driven by a device that provides force feedback. These can include a contact sensor that detects an operator's grip on the handle of the tactile/haptic device: if the operator lets go of the handle, the robot will stop its activity and go into a safe mode.

Robot-like manipulators are under the control of operators in different fields. A crane in a construction site can be driven by an operator manoeuvring a joystick on a tool worn about the waist. Bomb disposal robots, robotic arms in space and undersea manipulators allow action at a distance in dangerous or hostile environments. In each of these examples, the control tends to be a set of wheels or levers matched to Cartesian coordinates, or even joint coordinates.

Active tactile/haptic devices can be used in conjunction with minimally invasive surgery. Such systems give valuable feedback to the operator on the location of tissues and their characteristics. They can also provide guidance in the form of “virtual fixtures”, haptic pathways that guide the device to a target position under control of the operator, or prevent the device from going into an area that has been declared “off limits”.

Unique issues come from applications of remote operation with long time delays, e.g. “handshakes across the Atlantic”. Such simple applications can involve haptic loop operation without instability. Another example involves long-distance palpation of tissue, or needle insertion with the doctor in one continent and the patient in another.

On a smaller scale, tactile/haptic devices can be used with scanning probe microscopes to “feel” the atoms composing the surface of a crystal.

## 5.6 Medical

Virtual-reality-based tools in medical training have become common. Simulators allow students to practise skills before trying them on real patients. They can also practise procedures that are uncommon, and this has many safety benefits. Experts can also plan and rehearse particularly complex tasks before they begin practising on a patient. Simulators that only provide visual feedback miss many of the most important parts of performing an examination or surgical procedure and haptics can be used to allow touch-based skills to be learned in a safe way.

Minimally-invasive surgery (MIS), which is a very difficult skill to learn, can greatly benefit from haptics. Long, flexible tools are inserted through small incisions in the patient. Surgeons see what they are doing via small video cameras inserted along with the tools. The tools reduce the feeling that the surgeons get from open surgery, but touch is critical in identifying otherwise obscure tissue planes, blood vessels, abnormalities and gauging optimal forces to be applied for tissue manipulation. Coupling MIS tools to tactile/haptic devices and complex graphical models means that training can be given in a very realistic way. Surgeons can learn how to manipulate the tools without causing damage, the types of forces to be applied and the sensorimotor skills needed. Recordings can also be made of their virtual surgery that can then be played back for later analysis. All this can be done without any harm coming to patients during the learning process.

In the veterinary domain, researchers have developed simulators for teaching palpation and pregnancy diagnosis in horses and cows using force feedback. In these species, pregnancy diagnosis is an internal examination done purely through touch. It is difficult for students to learn and for teachers to teach; students cannot see what they are doing and teachers cannot easily tell if a student is performing the technique correctly. A mistake can have serious consequences for an animal. The simulators allow students to feel the animal's ovaries to learn what to feel for and how hard to press. They also allow the students to learn key landmarks within the animal so that they can find the correct locations to palpate.

Haptics has also been used for the patients themselves. Tactile/haptic devices can help people relearn control and movements after a stroke. The tactile/haptic device can initially help patients relearn by applying drag to an arm, e.g. to help the patient regain control and accuracy in movements. As the patient gets stronger, the device can offer increasing resistance, so that muscle strength can also be regained.

## 5.7 Gaming

Haptic interaction technology is widely used in game application interfaces. The mass marketing of games has led to a mass market for various types of tactile/haptic devices, many of which can be used for applications other than games. Haptic interaction technology is finding its way into games played with a computer. Whether games of chance or virtual adventure games, the sense of touch adds a new dimension of realism to the experience.

A typical game involving haptic controls is driving simulation. This might involve a steering wheel as well as accelerator and brake pedals. The roughness and profile of the road can be transmitted to the user through hands, feet or the whole body. Indeed, such interaction is also associated with large-screen productions through the use of motorized seats. Due to the short range of motion of such devices, the primary means of transmission is through acceleration and jolt effects. The degree of user control over the game, such as the path of the virtual automobile, is a matter of design and complexity.

User interaction with games of chance can be enhanced by the use of a haptic panel, in which each button press is associated with a particular mode of vibration. One button can feel like a soft spring, the next can be a sequence of vibrations of different frequencies, and a third button can simulate the roll of a pair of dice.

In sports simulators, use is made of 3D locators that allow a player to simulate, for instance, the swing of a tennis racket or a golf club or the striking of a pool or billiards ball. It is difficult, but not impossible, to ground such devices so that the user presses against a fixed restraint. On the other hand, the impact felt on hitting an object can be simulated using hand-held haptic equipment. The increased sense of realism in such situations is compelling, as long as there is close association between all modalities, i.e. haptic, visual and audible cues.

## 5.8 Art and creativity

Haptics makes possible a range of novel musical instruments. Based on sensors and reactive components such as levers, the devices give artists new means of expression. A “thumb piano” consisting of protruding rods that can be struck allow the musician to try out different gestures. A tactile/haptic device can simulate the action of a bow on a violin string or mimic a percussion instrument.

A “haptic paintbrush” can allow an artist to apply virtual paint to a canvas. Force feedback allows the artist to apply the paint using the sense of touch as well as the eye. It is possible to sculpt from virtual clay models using tactile/haptic devices. Parts can be carved out of the models by feel and sight, and new “clay” can be added to the model.

Animation software uses many tools to make the development of cartoons more efficient. One innovation has the sequence of animation tied to a line in virtual 3D space that can be pulled and pushed by a tactile/haptic device. By adding varying resistance to certain motions, the sequence can be “fine-tuned” using the precise movement of a tactile/haptic device. In principle, it would be possible for an artist to present a creation using graphics and touch sensing. Tactile/haptic devices next to a presentation could allow the observer to both see and feel a sculpture, whether in virtual space or some form of “augmented reality” that has a 3D virtual display laid on top of an actual 3D object.

From a commercial point of view, a company could present product catalogues with the help of tactile/haptic devices. One could imagine a selection of cloth fabrics that offered the possibility of feeling the texture of the material, or power tools whose operation could be seen and felt.

## 5.9 Multimodal applications and simulators

2D and 3D force feedback displays enable interaction designers to provide other means of feedback. Drivers, skippers or pilots may be trained to control a vehicle in large-scale haptic displays (simulators). For example, a flight simulator is a cabin mounted on top of a mechanical system (electronic motion base or hydraulic lift system). The simulator reacts to user input and events within the simulation. As the pilot steers the aircraft, the module he or she sits in twists and tilts, giving the user haptic feedback. Some flight simulators include a completely enclosed module, while others simply have a series of computer monitors arranged to cover the pilot's field of view.

To increase the sense of presence in the virtual scenes, non-visual modalities such as speech, sound or music may be added. For example, some entertainment parks create for visitors the sense of being present in a film scene (and even emotion) by adding realistic fire effects, fog, sudden water streams or tornados. Haptic feedback is created by shaking the vehicles the visitors sit in or by sliding the benches they sit on.

*Multimodality* refers to interaction with systems that include multiple output channels and multiple input devices. Typically, a multimodal interaction can be performed in many ways, either replacing some modality or adding modalities in a redundant way. For example, in the “Put That There” study, pointing at some object in a 3D scene may be accompanied by spoken commands. Users experience multimodal interactions that are more natural, they make fewer errors and the accuracy needed for recognizing input can be improved.

Multimodal interaction is also commonly found in assistive technology for blind people and people with low vision. Braille displays are read by exploring and reading the tactile display with fingers. Speech output is synchronized with Braille output and reduces the number of errors and misunderstandings in interactions. Today, planar haptic displays are often built as touch-sensitive input devices and allow localization of single or multiple fingers. Assistive technology applies this concept to the recognition of gestures while reading. A blind user may read Braille with his or her fingers, but speed up his/her movement towards the end of the line in order to create a gesture command for switching modality. Instead of reading Braille, the computer will generate speech, and the reader who has reached the end of a Braille bar will listen to spoken output.

Tactile maps present tactile information about geographical entities through audiohaptic interaction. Textures, lines and other relief structures allow bimanual exploration. Touching a tactile map with input facilities will generate spoken output to inform the user about, for example, the names of places and streets. A pin-matrix device with more than 7 000 pins can be used to implement a tactile map and update the geographic information dynamically.

## 6 Designing tactile/haptic interactions

### 6.1 Design guidelines for tactile/haptic interaction

#### 6.1.1 Human-centred design

Tactile/haptic interactions should be designed within the context of the human-centred design activities described in ISO 9241-210.

#### 6.1.2 Design of individual interactions

Individual interactions should be designed taking into consideration ISO 9241-110.

#### 6.1.3 Design of tactile/haptic interfaces

Tactile/haptic interfaces should be designed based on available ergonomic guidance relating to the applicable hardware and software user interface elements, including the following:

- a) the selection of the appropriate dialogue techniques for the interaction;
- b) the principles and design criteria for physical input devices from ISO 9241-410;
- c) the characteristics of presented information from ISO 9241-12.

NOTE 1 Current guidance on dialogue techniques can be found in ISO 9241-14 to ISO 9241-17.

NOTE 2 Although the characteristics referred to in c) above were developed for visual displays, they can also apply to the design of tactile/haptic input and output.

NOTE 3 Use of haptic displays can mean that more time is required to comprehend the information than with a visual display.

## 6.2 Designing tactile/haptic space

### 6.2.1 General

**6.2.1.1** Tactile/haptic objects and physical, temporal and logical spaces should be in accordance with the guidance of ISO 9241-920.

**6.2.1.2** The design of tactile/haptic interactions should consider the physical, temporal and logical spaces in which they occur.

- a) **Physical space** involves the layout, position and configuration of tactile/haptic objects relative to the user and to other objects that the user might interact with. Dimensions are important in the design of physical space.
- b) **Temporal space** involves the use of temporal parameters in tactile/haptic interaction, including the waveform of the stimuli, the rhythm and other temporal patterns, temporal changes in the amplitude and frequency of the stimuli, and temporal use of several tactile/haptic actuators.
- c) **Logical space** provides a conceptual understanding of how the user interacts with objects and information. The application being used generates the logical space. It contains structured information, relationships (such as linear, hierarchical or networked) and interaction techniques. Logical space is independent of modality of the rendering. Relationships are important in the design of logical space.

The mapping of logical space onto physical and temporal spaces might be constrained by the need to balance exploration and presentation.

**NOTE** The design of interactions with video displays involves layout of user interface elements in limited two dimensional spaces. Because of the limitations of this space, design tends to focus on the visual aspects of this layout, with little consideration for the user actions required to work with the user interface elements that are located in this space. The design of tactile/haptic interactions can involve the layout of tactile/haptic user interface elements within potentially unlimited three-dimensional space. It also involves the design of user actions and reactions within this space.

### 6.2.2 Designing logical space

**6.2.2.1** Logical space should be modality-free.

**6.2.2.2** The design should expose and clearly reflect the relationships within the information.

### 6.2.3 Designing physical space

**6.2.3.1** Relationships within physical space should comply with the ergonomic guidance with regard to spatial orientation and direction of movement provided by ISO 1503.

**6.2.3.2** The dimensions and contents of the physical space where tactile/haptic interactions take place should consider the ability of users to act and react within this space.

**NOTE** Related ergonomic guidance includes ISO 9241-5, which provides guidance on workstation layout and postural requirements, ISO 11064-4, which provides guidance on layout and dimensions of work stations for use within control rooms, and EN 894-4, which provides ergonomic and safety guidance on the location and arrangement of displays and control actuators.

## 6.3 Addressability and resolution in tactile/haptic interaction

### 6.3.1 General

Addressability and resolution should be considered in the design of tactile/haptic interactions.

A characteristic of a tactile/haptic sensory system is that information can flow both ways. Information flow is necessary from device to user, but there can also be a flow from user to device.

From the system perspective, both user and device have their own output addressabilities and input resolutions.

**EXAMPLE** A tactile display presents stimuli to the fingertips using rods set on a rectangular grid; the resolution and dimensions of the grid are established by the design of the device.

For each information pathway there is an addressability of the sender and a resolution of the receiver. For example, in the case of a device that provides force feedback, the device generates a force with a particular addressability and the user perceives this force with a specific resolution. At the same time, the user moves to a position with a specific addressability and the device measures this with a particular resolution.

Addressability and resolution apply to all parameters of tactile/haptic interaction, including the temporal dynamics of signals.

As with any type of display, the sensations set up by the individual data points can be, and are, integrated into a conceptual image, e.g. a surface.

### 6.3.2 Tactile/haptic output addressability

The addressability of a tactile/haptic device is a physical characteristic of the device itself. It establishes the individual points at which data can be presented (data points). The data points can be arranged in any way appropriate to the application, e.g. in a linear array – straight or curved – as shown in Figure 2 a), or in a two (or more) dimensional array, as shown in Figure 2 b).

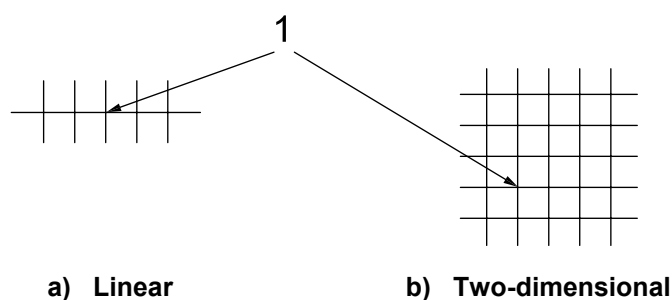

#### Key

1 data point (point at which data are either presented or sensed)

**Figure 2 — Linear and two-dimensional arrays**

The spacing of addressable data points can, therefore, differ from axis to axis and, indeed, even along the length of any axis. However, addressability does not normally vary greatly between axes on the same display device. This is especially true where a recognizable representation of an object is required.

The addressability of a user is fixed by the user's perceptual and motor control capability.

6.3.3 Tactile/haptic input resolution

6.3.3.1 Device

The tactile/haptic resolution of a device defines the degree to which the physical output from a user can be utilized by the device.

6.3.3.2 User

Resolution is directly related to the disposition of a user's touch sensors in, for instance, the fingertip. The more sensors per unit area, the greater the potential resolution ability.

Figure 3 shows addressable data points (taxels) being sensed by human touch sensors with resolution capabilities of four and nine taxels respectively.

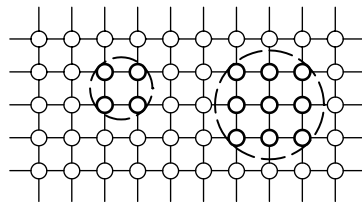
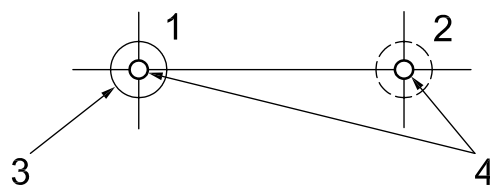

Figure 3 — Addressable data points

6.3.4 Tactile/haptic resolution and its relationship with tactile/haptic addressability

In most cases, as illustrated for instance in Figure 3, the addressability of a device is set to be at least as fine as the available human ability to resolve the data points. This means that data points, or the gaps between them, cannot be resolved individually.

In some applications, however, where each data point needs to be sensed by the human user and discriminated from another, it is important to have an addressability that is more widely spaced than the resolution that the user is capable of. The simplest example of this would be two points presenting different information, e.g. “Yes” or “No”, as shown in Figure 4.



Key

- 1 “Yes”
- 2 “No”
- 3 human touch resolution
- 4 addressable data points

Figure 4 — Two points presenting different information



With tactile/haptic devices, there is not only the need for the human user to sense (feel) information displayed by the tactile/haptic array, but also the need to be able to impart forces to the device in reaction to resistance to movement from the tactile/haptic device.

The ability to impart forces is necessary in order to allow the user to explore the physical characteristics of a virtual object. Characteristics such as hardness, roughness and elasticity can be explored by applying pressure with the fingertip (i.e. force divided by contact area). The human addressability in applying force is less than the addressability when merely sensing, since applying force is a less precise action than sensing.

## 7 User-initiated interactive task primitives

### 7.1 General

Users can carry out application tasks by employing one or more task primitives enabled by the tactile/haptic device and its associated software. Task primitives are provided by system functionality to users as tools for carrying out the tasks for which the device is designed. In any task, the user should be able to

- search,
- gain an overview,
- navigate,
- target,
- select, and
- manipulate.

### 7.2 Searching

The system should allow users to initiate a search for a specified tactile/haptic object, for part of an object or for an item of information and, once the search has been conducted, have the required result presented to them.

**NOTE** This might be contrasted with “targeting” of an object (see 7.5). To “target” an object implies finding something that is immediately apparent; to “search” for an object implies undertaking a task of longer duration than targeting.

**EXAMPLE 1** Searching by a device that provides force feedback with a single point of contact for haptic objects is supported by creating some force directed at the centre of a haptic object not so far visited.

**EXAMPLE 2** Searching for text on a Braille display involves locating strings that are possibly separated by large gaps. Experienced Braille readers use one finger for searching the beginning of new text (the haptic objects), and another finger for navigating on haptic objects.

### 7.3 Overviewing

The system should allow users to get a rapid overview of the tactile/haptic objects, their layout and relationships to each other and the user.

**NOTE** Providing an effective overview is important for simplifying the navigation and exploration process but can be difficult to do using single-point-of-contact tactile/haptic devices.

**EXAMPLE** An overview is provided through small-scale haptic objects. The overview makes clear whether navigation starts from outside of the haptic object or from inside the haptic object.

## 7.4 Navigating

**7.4.1** The system should allow users to move in and between tactile/haptic objects in order to find an object and to explore the space.

**7.4.2** The system should allow users to identify their location in tactile/haptic space and find the optimal path to get to required objects or information.

NOTE 1 Navigating can be difficult and failure can result in users becoming “lost in tactile/haptic space”.

NOTE 2 See ISO 9241-920:2009, 6.1.

NOTE 3 In the case of tactile/haptic interaction, navigation task primitives can enable navigation in a large number of dimensions, e.g. degrees of freedom in physical space and multiple points of contact, including multiple body parts.

NOTE 4 The provision of an overview to start the navigation process is important. However, this can be difficult to provide in the tactile/haptic display being used for interaction. An additional tactile/haptic display or alternative modalities can be used to provide the overview.

EXAMPLE Navigation is performed by tactile/haptic devices combining a pointing device with tactile feedback. This might be done manually, using large arrays of tactile pins supporting a sweeping movement of fingers, or by mechanical arms providing a point of contact to be touched by a finger.

## 7.5 Targeting

The system should allow users to identify and find an object or item of information accurately and rapidly.

NOTE 1 To “target” an object is to find it quickly and efficiently; to “search” for an object is to undertake a process to uncover something that is not immediately apparent.

NOTE 2 An object can be selected following either a search for or targeting of the object.

EXAMPLE A device that provides force feedback carries buttons or other sensors adjoined to a single-finger point of contact such that the hand does not move and only one or more other fingers are needed to activate a sensor when targeting objects.

## 7.6 Selection

### 7.6.1 General

The system should allow users to select objects singly or in multiples.

NOTE This will normally result in the de-selection of any object, or objects, previously selected, except where a serial group selection is intended.

### 7.6.2 Object or function selection

**7.6.2.1** The system should allow users to select any object or function to which they currently have access.

**7.6.2.2** The system should allow users to do this separately from performing any action on the object, for example activation.

**7.6.2.3** It should be clear to which objects or functions a user currently has access. Clear feedback on selection should be given.

NOTE This involves being able to choose one object from many and implies the ability to recognize the correct one by means of individual characteristics.

EXAMPLE On Braille displays, selection is possible through so-called routing keys. These sensors are located next to a Braille cell, are triggered by a pin's movements when touched or by a touch sensor built into the surface of the device, and can be activated for selecting a Braille character or activating a menu option.

### 7.6.3 Group selection

The system should allow users to select any defined group of objects to which they currently have access.

NOTE This involves being able to choose a group of objects from many and implies the ability to recognize the correct ones by means of classes of individual characteristics.

### 7.6.4 Space selection

The system should allow users to select any defined portion of the tactile/haptic space to which they currently have access.

NOTE This involves being able to choose a portion of space from the whole and implies the ability to draw a boundary around the correct portion.

### 7.6.5 System property selection

The system should allow users to select any property of the system to which they currently have access and change that property where permitted.

## 7.7 Manipulation

### 7.7.1 General

The system should allow users to operate on, manage or otherwise influence an object in ways that are appropriate to the task.

### 7.7.2 Zooming

The system should allow users to change the scale of the tactile/haptic space in which they are performing a task.

NOTE This will have the effect of changing the magnification of the perceived “view” and everything in it.

### 7.7.3 Reorienting

The system should allow users to change the orientation of the tactile/haptic space in which they are performing a task.

NOTE This will have the effect of changing the aspect, and possibly also the position, of the object relative to other objects or markers.

### 7.7.4 Moving

The system should allow users to move an object within the tactile/haptic space.

NOTE This could be carried out by attaching a virtual pointer to the selected object and applying forces in the desired directions until the object presents the required aspect in the required new position. The pointer will then be detached from the object.

### 7.7.5 Sizing

The system should allow users to change the size of an object within the tactile/haptic space.

### 7.7.6 Attribute inspection

**7.7.6.1** The system should allow users to inspect the attributes of objects within the tactile/haptic space without activating them.

**7.7.6.2** The system should allow users to determine which properties are modifiable and which are not.

**EXAMPLE** The stiffness of soft objects is inspected without the haptic object's surface becoming unrecognizable due to any reflecting force, as in rubber-band applications.

### 7.7.7 Creation and deletion

The system should allow users to create and delete objects in the tactile/haptic space, where appropriate to the task.

### 7.7.8 Modifying attributes (attributes and relationships)

The system should allow users to modify attributes of tactile/haptic objects, where appropriate to the task.

**EXAMPLE** Users are able to modify the texture of an object to suit their capabilities or preferences.

## 8 Tactile/haptic interaction elements

### 8.1 General

Tactile/haptic elements are software building blocks which can be combined to generate complex patterns of tactile/haptic communication to acquire information from, and convey it to, the user.

Tactile/haptic elements have two parts: tactile/haptic effects and object properties. Within tactile/haptic effects there are functional effects and time-dependent effects. Within object properties there are general properties and surface properties.

**NOTE** When haptic effects are at a frequency beyond the dynamic range of user interaction, especially when being run at such frequencies, haptic effects are unidirectional and only present information to the user.

### 8.2 Tactile/haptic functional effects

#### 8.2.1 General

Tactile/haptic functional effects alter the generated haptic feedback as a function of the measured reaction of the user.

**NOTE 1** Effects based on kinaesthetic perception are usually bidirectional, whereas tactile effects are usually unidirectional.

**NOTE 2** Since tactile effects are unidirectional only, tactile devices are often referred to as *tactile displays*, emphasizing the unidirectional properties of information presentation, as with acoustic or visual displays.

**EXAMPLE** With an impedance-controlled device, functional effects alter the force output of a device, depending on the position of the probe, for example to simulate a spring effect.

#### 8.2.2 Activation and deactivation of effects

All tactile/haptic functional effects available for a certain tactile/haptic device should be able to be activated and deactivated independently and should not influence each other.

### 8.2.3 Force vector

A force vector can be added to the tactile/haptic feedback at the probe's current position independent of the current orientation of the probe.

NOTE Where a single-point contact is involved, in terms of orientation, it usually does not matter whether the user wears a thimble or holds a pen.

### 8.2.4 Force field

The force-field effect adds a force vector to the tactile/haptic feedback which is parameterized in space and dependent on the probe's position.

NOTE Coordinates of a force field can be parameterized in lines or cubically depending on the workspace of the virtual space.

EXAMPLE 1 A gravity well is a force field that is parameterized in cubic coordinates in space and that adds a force vector with exponentially increasing amplitude when moving the probe towards a defined point in space.

EXAMPLE 2 A magnetic field is a type of force field that is parameterized in field lines in the space around a magnet.

### 8.2.5 Spring effect

A spring effect should generate a force proportional to a given factor and the distance of the probe's position from a defined point.

### 8.2.6 Damping effect

A damping effect should generate a force proportional to a given factor and the velocity of the probe's movement.

### 8.2.7 Mass effect

A mass effect should generate a force proportional to a given factor and the acceleration of the probe's movement.

### 8.2.8 Temperature field

A temperature field defines a certain temperature for the tactile/haptic feedback, depending on the probe's position in the virtual space.

NOTE The low bandwidth of common temperature displays has to be considered when designing a temperature field type of functional effect.

## 8.3 Tactile/haptic properties of objects

### 8.3.1 Properties of objects

Objects can be given tactile/haptic properties.

NOTE Haptic object properties in some respects parallel terminology and applications in the visual representation of objects, especially concerning geometric properties such as position, size and shape. In other respects, such as weight, temperature and material properties (soft-hard, smooth-rough), haptics might be unique and provide information not available through vision or hearing.

### 8.3.2 General object properties

#### 8.3.2.1 Position, shape and size

Position, shape and size can be used to differentiate between tactile/haptic objects.

#### 8.3.2.2 Stiffness

Stiffness represents the haptic response to interactions involving force normal to an object's surface.

NOTE 1 This response can be linear, with a factor proportional to the penetration depth. The depth can be calculated between the initial impact point (between the probe and the object) and the instantaneous position of the probe within the virtual object. It might also be calculated by an interpolation of the probe to the closest surface of the object.

NOTE 2 A proxy object is sometimes employed. This proxy object rests at the point of initial contact so that the depth can be calculated as the distance between the proxy object and the instantaneous probe position. As the probe moves inside the virtual object, the proxy object might roll about on the undeformed surface of the virtual object.

NOTE 3 Achievable stiffness could be affected by mechanical friction, haptic loop frequency, inertia, mechanical stiffness and spatial resolution.

### 8.3.3 Surface properties

#### 8.3.3.1 General

The tactile/haptic object's surface can be represented using different properties. For highly realistic impressions of virtual objects, all properties can be implemented.

#### 8.3.3.2 Frictional surface

Tactile/haptic elements can have different levels of friction. Friction can be modelled by various means.

NOTE 1 Those haptic effects resulting from a frictional surface include static friction, a force which hinders movement at its beginning, and dynamic friction, a force which works continuously in the opposite direction to the movement. The dynamic friction can be dependent on the velocity of the movement.

NOTE 2 Friction can be modelled in various ways.

#### 8.3.3.3 Magnetic surface

A magnetic surface attracts the contact point of the device when the distance between the probe and surface falls below a certain value. The attraction force can have a functional dependency on this distance — for example, it might decrease linearly with distance.

NOTE Magnetic surfaces can also be described as “sticky”, depending on the parameterization of the force.

#### 8.3.3.4 Texture

Texture is a periodic alteration of the shape of the surface of an object on a small scale. The texture of a surface can be actively explored by the user.

NOTE 1 Texture can usually be described as an arbitrary basic element that is repeated periodically over the whole surface to save computational power.

NOTE 2 The ability of a tactile/haptic device to display texture depends on the resolution of the sensory system.

### 8.3.3.5 Roughness

Roughness is presented as an aperiodic variation in the surface profile.

NOTE 1 Whereas texture has periodic properties, roughness normally is described with stochastic properties. See Figure 5.

NOTE 2 Roughness can be implemented using bursts.

NOTE 3 Tactile/haptic elements might have different levels of roughness. Roughness sometimes is presented as a sinusoidal or random variation in the surface profile.

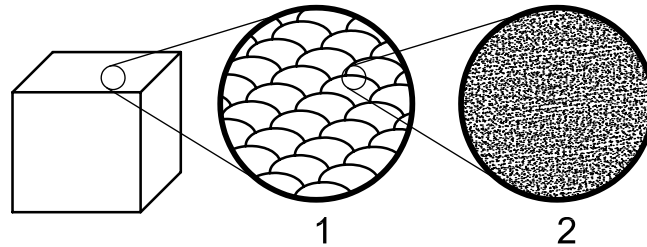

#### Key

- 1 texture
- 2 roughness

**Figure 5 — Relation between shape, texture and roughness**

### 8.3.3.6 Thermal properties

A surface can have certain thermal properties, such as temperature and thermal conductivity.

NOTE Defined thermal properties can lead to improved realism of virtual environments.

## 8.4 Control elements

### 8.4.1 Elements with haptic feedback

The workspace of tactile/haptic interaction might include control elements with haptic feedback, such as buttons.

NOTE In Braille displays, these buttons are used for routing.

### 8.4.2 Elements without haptic feedback

The workspace of tactile/haptic interaction might include control elements without haptic feedback, such as touch-sensitive surfaces.

## 8.5 Using multi-point-contact interfaces

The use of device-body interfaces with multiple physical contact points between user and device allows additional tactile/haptic interaction elements to be employed, thereby extending the range of information transfer.

EXAMPLE 1 A display with two contact points can display shear forces to the user by producing two force vectors with different directions.

EXAMPLE 2 Braille displays use multiple contact points to display a certain character.

## 8.6 Combining elements and effects

All elements and effects mentioned above can be combined to create complex interaction patterns.

## 8.7 Distinguishability

All patterns created should be tested for distinguishability by the user.

NOTE It is intended that future parts of the ISO 9241 "900" subseries deal with evaluation and measures of tactile/haptic interactions.

# 9 The range of tactile/haptic interface devices

## 9.1 General

Tactile/haptic devices primarily interact either through the cutaneous (skin-based) sense or through a combination of both cutaneous and kinaesthetic senses.

NOTE 1 See Annex A for an informative survey of tactile devices.

NOTE 2 See Annex B for an informative survey of tactile/haptic devices providing force feedback.

## 9.2 Selection criteria

### 9.2.1 Mobility

The mobility required for the task should be considered when choosing a tactile/haptic device.

NOTE 1 Portable devices can be grounded to the back, the upper arm and/or forearm, or to the point of holding or of attachment to the body.

EXAMPLE 1 An arm exoskeleton is used to augment the strength of the human arm. It can be supported by the back of the user, but tethered by a cable to a rack-mounted control system and power supply.

EXAMPLE 2 A mobile phone in a pocket can be set to vibrate rather than to produce an audio ring tone, reducing disturbance to others.

NOTE 2 Non-portable devices can be grounded to a desk, the wall, the ceiling or the floor.

EXAMPLE 3 An arm exoskeleton is attached to the wall or to a floor-mounted service manifold behind the user.

EXAMPLE 4 Chairs in a cinema are supported by mechanisms that vibrate, jolting the viewers in order to increase the sense of involvement in the motion picture.

EXAMPLE 5 A user grasps the pen-like handle of a tactile/haptic device to the right or left of his/her visual display.

### 9.2.2 Device-body interface

The point(s) of contact between the body and the device should be considered when choosing a tactile/haptic device.

NOTE 1 A haptic stimulus can be received through both touch and kinaesthesia. If information is to be conveyed primarily through touch rather than through the action of sensed muscles, then a tactile device can be considered.

EXAMPLE 1 A deaf user wears a tactile display that conveys audio frequencies to the skin of his abdomen.

NOTE 2 There can be multiple points of contact. These can include fingertips, two or more whole fingers, the right or left hand in various grips, both hands, one or two arms, the feet, or merely the ball or heel of each foot.



**EXAMPLE 2** Musical instruments typically involve multiple points of contact to allow a wide variety of gestures in the production of music. The console of a pipe organ presents a multiplicity of piano-like keys for both fingers and feet. Each key is analogous to a 1 DOF (degrees of freedom, see 9.2.3) tactile/haptic device.

**NOTE 3** A tactile/haptic device can be actively touched and actively or passively sensed, or passively attached to the body and passively sensed.

**EXAMPLE 3** A desk-mounted tactile/haptic device is typically held and manipulated as the user interacts with a haptically enabled virtual scene.

**EXAMPLE 4** A user places her finger on a pin array to sense Braille characters sweeping by her finger.

**EXAMPLE 5** A mobile phone indicates the identity of the caller with a specific vibratory haptic signal.

**NOTE 4** Tactile devices can be integrated into clothes or wearable components. It is important to ensure a mechanically stable coupling between the actuator and the skin during any body movement. It is important that the coupling does not encumber or irritate operators when performing other tasks. If the actuator becomes uncoupled from the skin, then the user will not feel any tactile feedback.

### 9.2.3 Degrees of freedom (DOF)

The number of degrees of freedom required for the task should be considered when choosing a tactile/haptic device.

**NOTE 1** The number of degrees of freedom is related to the dimensional nature of the information to be presented or explored.

**EXAMPLE 1** Frequency information is presented by vibration in a 1 DOF lever.

**EXAMPLE 2** Route information on a highway map is explored by haptic cues to a 2 DOF device.

**EXAMPLE 3** Seismic data in an oil field is presented with varying resistances to motion displayed by a 3 DOF device.

**EXAMPLE 4** A simulation of hand tools for aircraft engine maintenance involves a 6 DOF device to display torque as well as force.

**NOTE 2** The number of degrees of freedom with haptic feedback can be smaller than or equal to the number of degrees of freedom of the contact point.

**EXAMPLE 5** A 6 DOF tactile/haptic device has a 3 DOF translation stage with force feedback, surmounted by a handle stage with 3 DOF sensed rotation but with no torque feedback.

**NOTE 3** A device with a small number of DOF with haptic feedback typically gives a task metaphor, while a device with a large number of degrees of freedom typically attempts to recreate a task more realistically.

**EXAMPLE 6** A 3 DOF device simulates a point of contact that provides a convincing haptic representation of a topographic map showing an area of the earth's surface.

**EXAMPLE 7** A 7 DOF device (3 DOF translation, 3 DOF rotation, 1 DOF grip) simulates the action of a pair of surgical forceps being used to gently grasp and remove a severed polyp during a routine colonoscopy.

**NOTE 4** A tactile device can be fixed in location or mounted on a tactile/haptic device with one or more DOF.

**EXAMPLE 8** A tactile Braille display composed of an array of pins is mounted on a rail to enable the user to slide the array back and forth in order to actively scan lines of Braille text.

**NOTE 5** The size, density and number of stimuli in a tactile display can be governed by known distributions of haptic receptors in the skin. Each stimulus may be considered an independent DOF.

**EXAMPLE 9** An array of pins is denser because it is designed for fingertip use rather than for use applied to skin on the upper arm.

**EXAMPLE 10** A tactile array designed for the back of the torso is larger than one designed for a fingertip, and has a low density of stimulators.

### 9.2.4 Maximum stiffness

The maximum stiffness required for the task should be taken into consideration when choosing a tactile/haptic device.

NOTE 1 Stiffness relates to the feeling of rigidity or tautness when exploring a virtual surface. Both rigid and flexible virtual objects can exhibit stiffness.

NOTE 2 Stiffness might be perceived as three separate qualities in a haptic simulation — the crispness of initial contact, the hardness of surface rigidity and the cleanliness of final release from a surface. Some of these are under software control.

NOTE 3 High maximum stiffness in a haptic display is the result of a number of device design factors — spatial resolution, temporal resolution, mechanical stiffness and friction. Mechanical stiffness typically relates to a lack of spurious movement in joints, rigidity of mechanical links and lack of stretch in belts or tendons.

EXAMPLE 1 A device with poor spatial resolution only displays soft virtual surfaces.

EXAMPLE 2 A device with good spatial resolution can display a hard virtual surface. The same surface can be modified to a soft one under software control.

NOTE 4 A convenient test for maximum stiffness is to present the device with a virtual wall with adjustable spring constant and no damping. The maximum stiffness is the highest spring constant of the wall that can be explored by the device without generating vibration.

NOTE 5 Gripping the handle of a device tighter can improve the stiffness of a haptic presentation. Devices need to be compared using the same grip as much as possible.

NOTE 6 Adding physical damping to a device can increase the stiffness of the wall that can be displayed without vibration. Adding virtual damping might increase wall stiffness, depending on the digitalization rate.

EXAMPLE 3 Controllable physical damping is implemented by magnetorheological fluid braking, by reversing current in a d.c. motor, or by varying the magnetic field applied to a rotating aluminium disc.

EXAMPLE 4 A tactile/haptic device is built using variable braking only. Without motors, the device cannot send energy back to the operator. This limits the haptic effects that can be displayed, but it does guarantee stability.

### 9.2.5 Motion range

The motion range appropriate to the task should be taken into consideration when choosing a tactile/haptic device.

NOTE 1 Motion range is also known as *workspace*. The appropriate device motion range is typically determined by the planned range of motion of the device-body interface. This range of motion is determined in large part by the fulcrum of motion of the human body.

EXAMPLE 1 In the case of the motion of the human arm, the fulcrum can be the shoulder, the elbow, the palm side of the wrist or the outer lateral side of the hand (as in holding a pen to write). This list represents a decreasing workspace but an increasing precision in holding an instrument.

NOTE 2 Motion range typically consists of translational and rotational components. These can be partitioned, as in serial devices, or coupled, as in parallel devices.

NOTE 3 The definition of motion range can vary according to the degrees of freedom of the device.

- In a 1 DOF device, motion range can be the maximum distance or angle that can be reached.
- In a 2 DOF device, it can be the dimensions of the maximum area or solid angle that can be reached.
- In a 3 DOF device, it can be the dimensions of the maximum volume that can be reached.
- In a >3 DOF device, it can be the dimensions of the maximum volume that can be reached in translation, together with an appropriate description of the rotation limits of the other degrees of freedom.

NOTE 4 It is convenient to use simple geometrical shapes to describe the range of translational motion.

EXAMPLE 2 The workspace of a 3 DOF device could be described by a box, a sphere or an ellipsoid.

NOTE 5 With some devices, the handle rotation can be restricted towards the limits of the workspace.

## 9.2.6 Force and torque

### 9.2.6.1 Peak force and torque

The peak force and torque required for the task should be taken into consideration when choosing a tactile/haptic device.

NOTE 1 Allowance can be made for the capabilities of the intended operator. Peak force can be sustained for only a short time before muscle fatigue sets in.

NOTE 2 Force generally applies to 1 DOF, 2 DOF and 3 DOF devices; both force and torque generally apply to devices with more than 3 DOF.

EXAMPLE 1 Simulating both the torque and thrust of a screwdriver involves multiple DOF.

NOTE 3 Peak force torque can occur during a transient lasting as little as 10 ms.

EXAMPLE 2 Tapping on a simulated bone involves high transient force.

NOTE 4 Some tasks can require that peak force be considered for times as long as 5 s.

EXAMPLE 3 Pressing vertebrae to displace the spine in a surgical simulation could represent a sustained high force.

### 9.2.6.2 Maximum continuous force and torque

The maximum continuous force and torque required for the task should be taken into consideration when choosing a tactile/haptic device.

NOTE 1 Fatigue and discomfort are reduced if continuous forces are a small fraction of the maximum voluntary contraction. At higher fractions, the work-to-rest ratio becomes important.

NOTE 2 In an electromechanical tactile/haptic device, a sustained force or torque puts a motor into stall, causing heat to build up. The limiting parameter is the sustainable temperature of the motor.

### 9.2.6.3 Minimum displayable force and torque

The minimum displayable force and torque required for the task should be taken into consideration when choosing a tactile/haptic device.

NOTE 1 The use of light force is appropriate to some delicate tasks.

EXAMPLE 1 Simulating the use of tools to assemble a watch involves the use of small forces. Certain components could be damaged if gripped too hard.

EXAMPLE 2 Neurosurgeons work with very sensitive tissue and consequently apply light forces to surgical instruments.

NOTE 2 A tactile/haptic device with low friction is appropriate to the display of low forces.

#### 9.2.6.4 Force and torque resolution

The displayable force and torque resolution appropriate to the task should be taken into consideration when choosing a tactile/haptic device.

NOTE 1 In some tasks it is appropriate that levels of force and torque be distinguishable.

EXAMPLE There might be slight differences in forces involved in palpating anatomical tissue (i.e. examining tissue at a surgical site to determine its condition).

NOTE 2 A tactile/haptic device with low friction is appropriate for producing good force resolution.

#### 9.2.6.5 Dynamic force and torque range

The dynamic range of displayable force and torque appropriate to the task should be taken into consideration when choosing a tactile/haptic device.

NOTE Dynamic range is the ratio of the peak force to the minimum force.

EXAMPLE The simulation of orthopaedic surgery involves both high force to simulate touching a bone and low force to simulate touching tissue in the vicinity of the bone.

#### 9.2.7 Free-space motion resistance

The free-space resistance appropriate to the task should be taken into consideration when choosing a tactile/haptic device.

NOTE 1 Low free-space motion resistance indicates the ability to move the tactile/haptic device with minimal opposition throughout the workspace. Ideally, the device will not exert forces on the user's hand when there is no interaction with an object in the virtual world.

EXAMPLE 1 A tactile/haptic device with gear noise might introduce haptic effects that mask the intended haptic display.

NOTE 2 Free-space motion resistance can be composed of both steady forces and variable forces. Steady forces can include gear ratio, friction and inertia; variable forces can include gear noise, backlash (unwanted free motion in gears) and elasticity in transmission.

EXAMPLE 2 A brushless motor typically exhibits torque ripple, a variation in resistance that is felt periodically as the output shaft of the motor is turned.

NOTE 3 It is possible to have different values of free-space motion resistance for each DOF.

EXAMPLE 3 A device can have more inertia in the translation of its handle than in its rotation.

#### 9.2.8 Inertia

The inertia of the device-body interface in the device should be taken into consideration when choosing a tactile/haptic device.

NOTE 1 Inertia shows itself in free-space motion resistance as a perceived mass at the device-body interface.

EXAMPLE A tactile/haptic device with high inertia is harder to start pushing and more difficult to stop.

NOTE 2 Depending on the DOF and the design of the device, inertia can be translational inertia, expressed in units of mass, or rotational inertia, expressed in units of mass multiplied by distance squared.

NOTE 3 Inertia can be eliminated partially by control algorithms such as force or acceleration feedback, but these can bring with them other dependencies such as variation with frequency.

### 9.2.9 Peak acceleration

The peak acceleration of the device-body interface in the device should be taken into consideration when choosing a tactile/haptic device.

NOTE 1 Peak acceleration is peak force derived by inertia.

NOTE 2 High peak acceleration is evident in contacts and impulses that involve rapid changes of velocity.

### 9.2.10 Friction

#### 9.2.10.1 Static friction

The static friction limits of a task should be taken into consideration when choosing a tactile/haptic device.

NOTE 1 Static friction is resistance to moving the device-handle interface from a standing position.

NOTE 2 Static friction leads to stick-slip behaviour at low velocity. This can cause instability when attempting to model a virtual wall.

#### 9.2.10.2 Kinetic friction

The kinetic friction limits of a task should be taken into consideration when choosing a tactile/haptic device.

NOTE 1 Friction shows itself in free-space motion resistance. It is a perceived drag at the device-body interface. It always opposes motion.

NOTE 2 Kinetic friction is typically divided between Coulomb friction (friction independent of velocity) and viscous friction or damping (friction proportional to velocity).

NOTE 3 Ideally, a tactile/haptic device has minimal kinetic friction, allowing the user to add software-controllable virtual friction if it helps in rendering the virtual environment.

EXAMPLE Some control algorithms add virtual damping to improve the feeling of touching a virtual surface. Others have experimented with controllable physical damping to absorb energy and render a virtual wall passive.

### 9.2.11 Temporal parameters

#### 9.2.11.1 Bandwidth

The bandwidth appropriate to the task should be considered when choosing a tactile/haptic device.

NOTE 1 Bandwidth refers to the frequency range over which the tactile/haptic device provides feedback to the user. Commonly, we also refer to the upper frequency as the bandwidth, but the lower frequency is also part of the specification of bandwidth.

NOTE 2 The human haptic sensing capability has a much higher bandwidth than the muscle-driven output bandwidth.

EXAMPLE 1 The human tactile sensory system typically receives signals from the skin at a frequency range of 0 Hz to 1 000 Hz (although higher rates have been reported).

EXAMPLE 2 The human kinaesthetic sensory system receives signals from the muscles and joints at 20 Hz to 30 Hz. Fingers and hands can be moved with a 5 Hz to 10 Hz bandwidth.

NOTE 3 Fatigue and other physiological effects can be a factor affecting the human sensing bandwidth.

EXAMPLE 3 Signals presented rapidly at the same location on the skin may mask each other.

NOTE 4 The bandwidth of a tactile/haptic device typically refers to the whole haptic feedback loop. It is the number of times that the haptic loop can be implemented per second (also known as the update rate).

**EXAMPLE 4** In an impedance tactile/haptic device, the haptic loop includes, in sequence, sensing position in the device, iterating the haptic simulation, computing force and/or torque and sending force/torque instructions back to the tactile/haptic device.

**EXAMPLE 5** In an admittance tactile/haptic device, the haptic loop includes, in sequence, sensing force in the device, iterating the haptic simulation, computing position and sending position instructions back to the haptic device.

**NOTE 5** The bandwidth is affected by factors such as the rate of digitization of sensor signals in the tactile/haptic device, latency in the communications between the tactile/haptic device and the control computer, and the time taken to iterate the haptic simulation and compute information to be returned to the tactile/haptic device. There can also be limits on the ability of the device to display force and torque over the required frequency range.

**EXAMPLE 6** Suppose a tactile/haptic device is able to generate a force between 0 Hz and 1 000 Hz. If the position measurement is made at 10 kHz, then control signals are generated at a higher rate than that at which the device is capable of generating forces. This can diminish instabilities that originate in resonance between the simulation, the device and the user.

**NOTE 6** The mechanical impedance of the user's body at the device-body interface can affect the perceived bandwidth of the tactile/haptic device.

**EXAMPLE 7** A user grasps the handle of a tactile/haptic device rigidly, with hand and arm stiff, thereby reducing the ability of the device to display force over a wide frequency range. The skin sensors themselves might be overwhelmed by the grip and not be sensitive to small vibrations in the device.

### **9.2.11.2 System latency**

The system latency may be considered as an alternative expression of the bandwidth of a haptic system.

**NOTE** System latency is the total time lag of the components of the haptic loop. System latency is the inverse of the update rate.

**EXAMPLE** In an impedance controller, system latency includes the time to compute the forward and inverse kinematics of the device, any delay in communications between the device and the control computer, and the time to compute the force and torque output from the haptic simulation to the user.

### **9.2.11.3 Device latency**

The device latency may be considered as a device-specific contribution to the bandwidth of a haptic system.

**NOTE 1** Device latency is the time delay between sending a command to a tactile/haptic device and receiving a response from that device. It typically includes the forward and inverse kinematics, which could in fact be calculated on the control computer.

**NOTE 2** Device latency can be affected by the speed of the control computer, as well as by any delays inherent in the tactile/haptic device itself. The control computer speed may include central processing unit calculation rates, memory access times and time to access any input/output cards on a secondary computer bus.

## **9.2.12 Environmental factors**

### **9.2.12.1 Acoustic noise**

The acoustic noise of the device should be considered when choosing a tactile/haptic device.

**NOTE 1** High acoustic noise from a tactile/haptic device can make for an uncomfortable working environment.

**NOTE 2** Acoustic noise can originate in cooling fans or in mechanical vibrations that arise during the execution of the task.

**EXAMPLE** If the task requires the display of virtual hard surfaces, then acoustic noise could be generated as a tactile/haptic device with poor spatial resolution attempts to display those surfaces.

### 9.2.12.2 Weight

The weight of the device that might have to be transported during the task should be considered when choosing a tactile/haptic device.

NOTE 1 Heavy weight might be necessary for device stability, but it does make device transport more difficult.

EXAMPLE Displaying high peak forces in a lateral direction requires a heavy base, and/or a wide base, and/or clamping of the device to a fixed support.

NOTE 2 Electronics boxes and cables might also be considered in the weight budget.

### 9.2.12.3 Size

The size of the device should be considered when choosing a tactile/haptic device.

NOTE 1 The size of a tactile/haptic device might affect its location in the lab or office work area.

NOTE 2 The size is dictated to some extent by the workspace of the tactile/haptic device.

EXAMPLE A larger workspace implies a larger device, since a solid base and a long mechanical linkage might be needed to allow the device-body interface to be moved throughout the workspace. The mechanical linkage could sweep out a large volume during the task.

NOTE 3 Electronics boxes and cables might also be considered in the size of the device.

## 9.2.13 Safety

### 9.2.13.1 Mechanical safety

9.2.13.1.1 The mechanical safety of the device should be considered when choosing a tactile/haptic device.

9.2.13.1.2 The risk of actuators propelling parts of the device into violent contact with a user should be avoided or reduced.

EXAMPLE 1 A user sitting outside the workspace of the device in order to avoid being struck by the handle might still be in the path of linkages.

EXAMPLE 2 If the force of the tactile/haptic device is limited, then contact force on a user's body will be reduced.

9.2.13.1.3 Ways of shutting down the device when it is not being held should be considered.

EXAMPLE 1 A tactile/haptic device is equipped with a contact sensor to determine when the user is holding the device handle. When the hand is not present, the device is automatically held under braking or deactivated to prevent it from moving under power without control.

EXAMPLE 2 Control software for the tactile/haptic device has a "runaway" detector that shuts down the motors when uncontrolled motion is detected in one or more degrees of freedom.

9.2.13.1.4 The user of the device should be able to disengage from the device.

EXAMPLE If a tactile device over-stimulates a user's skin, then skin irritation or damage could occur, in which case the user will normally withdraw to prevent further irritation or damage.

### 9.2.13.2 Electrical safety

9.2.13.2.1 The electrical safety of the device should be considered when choosing a tactile/haptic device.

9.2.13.2.2 It should be ensured that the user of the device is shielded from dangerous electrical voltages.

9.2.13.2.3 Internationally recognized electrical codes (rules) should be followed to ensure the device's safety.

EXAMPLE The power supply of a device drawing heavy current from the electrical supply line employs an approved connector with a pin connecting to the electrical ground of the building.

9.2.13.2.4 If the electrical power fails, the device should enter a safe state.

EXAMPLE An exoskeleton may be supported on a stand and encompass the arms of a user. The device should be so balanced that if electrical power fails, the felt weight of the device will not endanger the user.

### 9.2.13.3 Thermal safety

The thermal safety of the device should be considered when choosing a tactile/haptic device.

NOTE Actuators and auxiliary electronics might get hot during the operation of a tactile/haptic device.

EXAMPLE 1 If the device is held against a virtual wall, then no work is done by the motor, and power to the motor is turned into heat.

EXAMPLE 2 Care is taken to ensure that the user is not exposed to hot surfaces.

### 9.2.14 Postural considerations

#### 9.2.14.1 Working position

The working position required by the device should be considered when choosing a tactile/haptic device.

NOTE 1 Some devices might be designed with the expectation that the operator will stand while using the device, while for others it may be expected that he or she is in a sitting or prone position.

EXAMPLE 1 A vibrating chair is designed for the user who assumes a sitting position during a task.

EXAMPLE 2 An exoskeleton is designed for the user who stands while operating the device.

NOTE 2 Some positions can be more tiring than others. For a task of long duration, it is important to consider the comfort of the user. The device might allow him or her to change position during the task, for example.

#### 9.2.14.2 Limb support

Human limb support to assist the user during the task should be considered when choosing a tactile/haptic device.

NOTE For some haptic tasks, the operator might be expected to extend an arm or a leg while operating the device. For the comfort of the operator, it is important to consider elbow rests or footrests, as appropriate.

EXAMPLE It might be expected that while operating a 3 DOF device, the user will raise her hand off the desk for extended periods of time. If a raised and relatively fixed position of the hand is expected for the task, a forearm support is provided.



## 9.2.15 Adaptability

### 9.2.15.1 Modification

Modification of the device required by the task should be considered when choosing a tactile/haptic device.

**NOTE** Research work sometimes involves modifying devices in order to comply with a new situation that has arisen during the course of the research.

**EXAMPLE 1** In order to test a new algorithm, a novel handle with a load cell (force sensor) is added to the device-body interface.

**EXAMPLE 2** To simulate the feel of surgical instruments in the hand of the surgeon, a new handle is fitted to the tactile/haptic device in place of the original handle.

### 9.2.15.2 Controllability

Special control of the device appropriate to the task should be considered when choosing a tactile/haptic device.

**NOTE** Modification of the operation of a tactile/haptic device can be aided by the use of buttons on the handle, or by software commands that change selected characteristics of the device.

**EXAMPLE 1** A button is pressed that allows “indexing” — moving the device to a new location in its virtual workspace so that the real workspace of the tactile/haptic device is in a more convenient position relative to the virtual workspace.

**EXAMPLE 2** Where recalibration of sensors is necessary, it is easy to do, and is preferably not a frequent occurrence during the execution of a task.

**EXAMPLE 3** There is a storage position for a device handle that also serves as the reference position for device angle sensor calibration.

### 9.2.15.3 Installation

Ease of installation should be considered when choosing a tactile/haptic device.

**NOTE 1** In most cases, a tactile/haptic device is installed and left in place for a long time.

**NOTE 2** If it is a requirement to move devices, the ease of interchanging control computers can be an important consideration in the selection of the device.

### 9.2.15.4 Reliability

The reliability of the device should be considered when choosing a tactile/haptic device.

**NOTE 1** It is preferable that tactile/haptic devices operate for many hours between repairs, giving trouble-free operation in the selected conditions of use.

**NOTE 2** It is important that manufactured devices are well tested before being delivered to the customer.

**NOTE 3** It is important that tactile/haptic devices withstand transportation without damage when transported according to the manufacturer's instructions.

### 9.2.15.5 Maintenance

**9.2.15.5.1** The ease of maintenance of the device should be considered when choosing a tactile/haptic device.

NOTE Repair to a tactile/haptic device is to be expected.

**9.2.15.5.2** The required time and difficulty of carrying out maintenance should be assessed.

**9.2.15.5.3** Ideally, routine maintenance tasks should be carried out locally, while more complex tasks should be undertaken by an appropriate service with minimal time delay.

**9.2.15.5.4** When purchasing a device, there should be a clear understanding as to the details of the manufacturer's warranty — what is covered and how long the warranty lasts.

### 9.2.16 Fidelity

The fidelity of the device in the carrying out of the task should be considered when choosing a tactile/haptic device.

NOTE 1 Fidelity is the ability of the haptic system to simulate real-world interactions. This is sometimes termed the “transparency” of the haptic system — the ability of the system to convince the user that he or she is interacting directly with the haptic scene.

EXAMPLE Tactile/haptic devices might be part of a walk-in, virtual-reality simulation that immerses the user in the context of another world, a virtual environment, e.g. a microscopic surgical site, a coal mine or a vessel in outer space. The impression of “being there” in person is heightened by the sense of touch together with other human sensing modalities.

NOTE 2 A high-fidelity device has good sensor resolution, fast, low-noise actuator response, low computer latency and transparent transmission of force, torque and/or tactile sensations to the user.

## Annex A (informative)

### Tactile devices

#### A.1 General

This annex describes a range of tactile devices most commonly found at the time of publication of this part of ISO 9241; nevertheless, it will also be applicable to other tactile devices.

Point-based devices (such as the pager motor) vibrate at a single point. Pin-array-based devices (such as refreshable Braille displays) have an array of pins which can press against the skin. Point-based displays can also be worn in an array across a larger area of the body.

#### A.2 Vibrating pager/telephone

Vibrating pagers or telephones contain an actuator, typically rotating but sometimes also translating, moving a mass at high speed (see Figure A.1). The changes of the movement direction of the mass result in oscillating forces to the actuator's environment. In an alternative realization, a mass being moved at high speed is suddenly stopped. This enables the generation of hard tactile clicks. Being part of, for example, a mobile phone, which itself can be carried in a pocket, the oscillations of the mass are coupled to the skin. This oscillation results in a displacement which itself now generates a haptic sensation. The intensity of the sensation can be varied by modifying the speed of the oscillation because the mechanical coupling and the actual sensation of oscillatory vibrations are frequency-dependent. The perception of the event can be enhanced by a careful choice of patterns of oscillatory bursts.

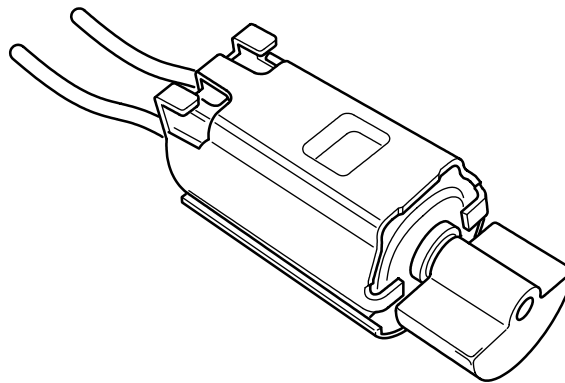

Figure A.1 — Vibrating motor with eccentric mass

### A.3 Linear tactile actuator

Another method of creating single-point vibrations on the body is the linear actuator. The contactor in the device shown in Figure A.2 is the moving mass itself, which is mounted above the housing and pre-loaded against the skin. This provides localized feedback, as only the contact point (the dot in the centre) vibrates and not the whole surrounding device (which occurs in a typical mobile phone containing a pager motor). Such devices typically resonate at around 250 Hz but are designed to be able to produce a range of frequencies, unlike many basic mobile phone actuators which have a limited frequency response.

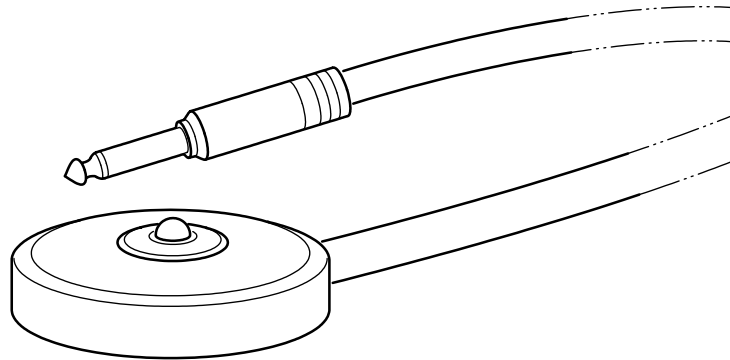

Figure A.2 — Linear tactile actuator

### A.4 Vibrating handheld controller

Vibrating handheld controllers are widespread in the area of console games. These devices contain one or more actuators comparable to that of a vibrating pager but with a larger mass and, therefore, more mechanical power. The control of the actuator is dependent on actions happening within the video game. When multiple actuators are mounted within one handle, even directional information can be encoded within the pattern of vibratory bursts.

### A.5 Pin-based displays

Pin-based displays have their origin in the application of the alphabet in Braille. The tactile elements (pins) used in these kinds of displays are located normal to the surface of the skin. Usually every pin is connected to an actuator, which responds according to one particular physical principle, e.g. thermal, electromagnetic, electrodynamic, electrostatic, piezoelectric, ultrasonic, pneumatic or hydraulic. The actuator is able to change its height according to a control signal. The change is usually discrete, having two digital stages (raised or lowered), but can also be continuous to encode an additional level of information within it. Typically, pin-based displays are made up of sets of actuators closely mounted to build up a large area for haptic interaction with many pins (see Figure A.3).

**NOTE** The actual resolution for the lateral distance of pin-based displays is subject to intense discussion and not yet finally settled. Also, the combination of the sensation of shear and the fact that users can be trained very well in the perception of pins still poses difficulties for deterministic design criteria.

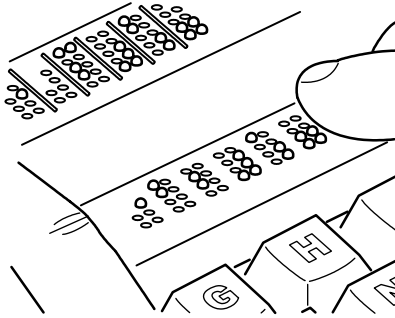

**Figure A.3 — Braille display as part of a computer keyboard**

There are two possible designs for tactile devices with respect to motion and information shown to the user. In the first variant, the device displays time-dependent information and the finger moves relative to the device to scan the information. In the other variant, the finger rests on the tactile component, which is part of a movable device for scanning distributed information by movement of the device. An example of the latter variant is a tactile display incorporated into a mouse (see Figure A.4). The arrays in the mouse have a higher resolution than those in a Braille display and can be used to present other forms of information, such as icons, diagrams or maps.

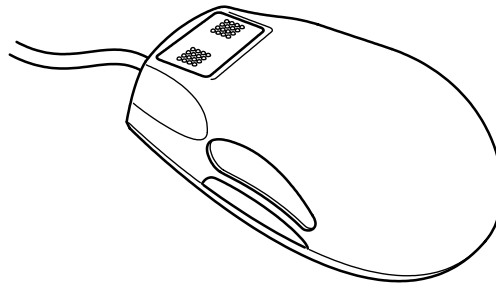

**Figure A.4 — Tactile mouse**

## A.6 Shear displays

Shear displays are devices which generate shear on nearby skin areas. The use of shear is motivated by the observation that the detection of single raised pins of pin-based displays increases if lateral motion between the pin itself and the skin is permitted. Shearing of the skin is a very relevant factor of everyday life in the secure grasping and holding of objects. Combining shear with normal deflection results in increased sensitivity. Several technical realizations of shear displays exist, including rotating drums over vibrating piezoelectric discs and surface waves. The sensation of shear can also be used to generate sensations similar to those experienced when exploring raised pin-based displays.

## A.7 Vibrating vests and belts

When addressing body parts with two widely separated points of contact, it is possible to use discrete actuators instead of banks of actuators to provide spatially distributed tactile information. Vibration actuators are often chosen for this purpose. Studies have investigated adding vibrating actuators to vests and belts, allowing surface or spatial information to be projected on to the body surface (see Figure A.5). The resulting applications range from navigation and orientation to the teaching of complex movements. However, the number of vibratory events that a user can process in parallel is limited.

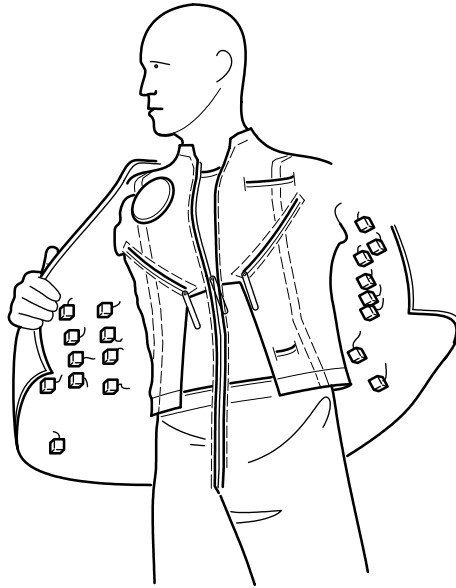

Figure A.5 — Tactile vest for military applications

## A.8 Thermal devices

Devices exist which address thermal perception. They usually consist of arrays of heated electrodes for providing spatial information about a thermal distribution. The problems associated with this technology surround a lack of understanding in the perception of thermal effects and the complexity involved in modelling the backlash of the human thermal skin management within the device itself.

## A.9 Electrical devices

Another possibility for stimulating receptors located in the skin is the application of defined electrical (a.c.) stimuli. Devices of this kind activate all receptors in parallel generating some tactile sensation. A big advantage of this approach is the high resolution possible by this very simple means. However, it has to be taken into account that electric stimulation is largely dependent on time-varying parameters in the electrical coupling to the skin, involving conversion between electron-based charge transfer and ion-based charge transfer. In addition, electrical stimulation always activates open nerve fibres responsible for nociception.

NOTE See C.2.4 for details of nociception.

## Annex B (informative)

### Tactile/haptic devices that provide force feedback

#### B.1 General

This annex describes a range of tactile/haptic devices providing force feedback most commonly found at the time of publication of this part of ISO 9241; nevertheless, it will also be applicable to other tactile/haptic devices providing force feedback.

#### B.2 Knob-based haptic devices

Knob-based haptic devices (see Figure B.1) are a typical choice for interactions in one degree of freedom (DOF). They contain one actuator driving a handle in the form of a knob or wheel, either directly or via a gear with a small transmission ratio. The torque versus angle characteristic is programmable, depending on the task to be performed. Typically, these devices are programmed with one or more specific characteristic curves. These curves are then selected via a simple protocol sent on a bus connector. The devices themselves send events to the system's host in the event that a certain function is selected. They are commonly used in cars for the combination of controls for radio, air-conditioning and multimedia functions in one operating device.

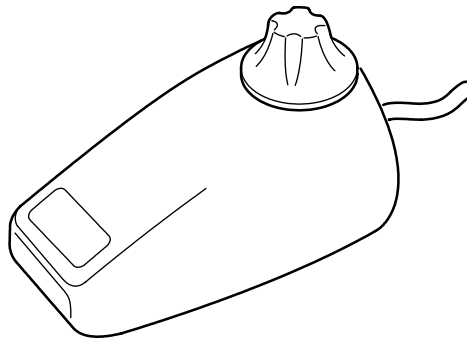
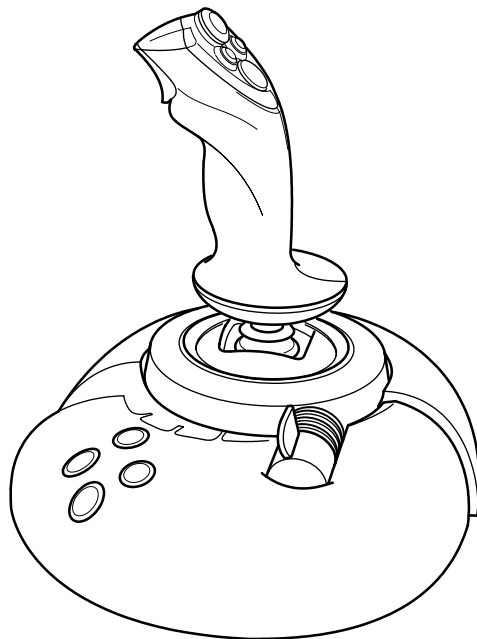

Figure B.1 — Rotary haptic knob

#### B.3 Joysticks that provide force feedback

Joysticks that provide force feedback (see Figure B.2) are control devices aimed especially at the gaming industry. They contain several actuators for altering the stiffness and damping of movement in at least two control directions. Additionally, these actuators can generate a force output to the user. The position in these control directions is measured and given to the host system, which is usually a personal computer. Typical applications generate haptic events in one or more of the kinaesthetic DOF to simulate the impact of weapons on the virtual character or a collision with objects within the gaming scenario.



**Figure B.2 — Joystick that provides force feedback**

#### **B.4 Steering wheels and pedals that provide force feedback**

Steering wheels and pedals that provide force feedback are control devices resembling the steering-wheel of a car and its gas and brake pedals (see Figure B.3). These products are motivated by the gaming industry and interface with personal computers as a host system. They contain several actuators generating a torque and force output on either one of the controls and provide information about the angle steered and the intensity with which the pedals have been moved.

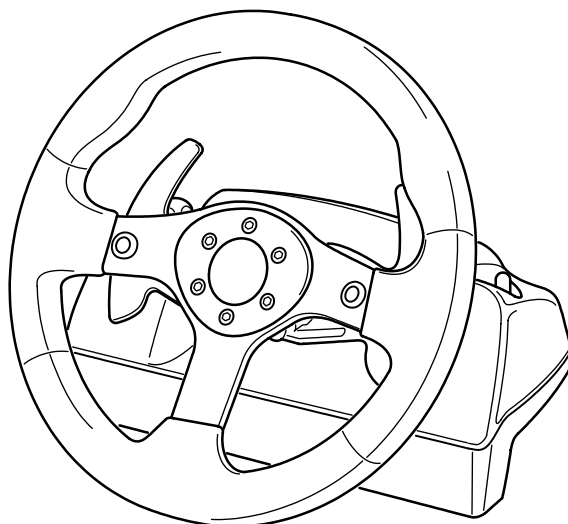

**Figure B.3 — Steering wheel that provides force feedback**



## B.5 Point-based haptic devices

The class of point-based haptic devices combines three DOF in one idealized point (see Figure B.4). This point is usually physically represented by a handle that can be exchanged to adapt to different usages. Due to typical demands including high stiffness of the technical system and a limited workspace for the user, such devices are often designed as parallel mechanisms. The number of actuators is identical to or higher than the number of degrees of freedom, with kinaesthetic feedback driving the kinematic chain. These point-based haptic devices usually interface with personal computers. They receive information about the force to be generated and provide positioning information back to the host computer.

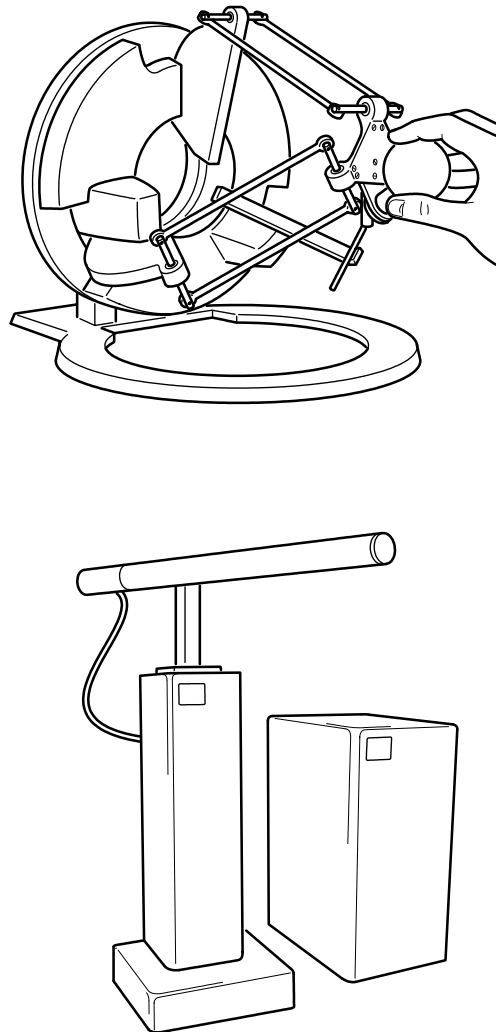

Figure B.4 — Point-based haptic devices

## B.6 Stylus-based haptic devices

Stylus-based haptic devices (see Figure B.5) control a point in three-dimensional space via an attached stylus. The orientation of this stylus is measured in addition to the positioning information of the point and — depending on the system — partly or completely equipped with kinaesthetic feedback. Stylus-based haptic devices are widely used in 3D applications for the design, film and modelling industries. They allow control of a virtual pen which represents the real tools for sculpting, painting or writing.

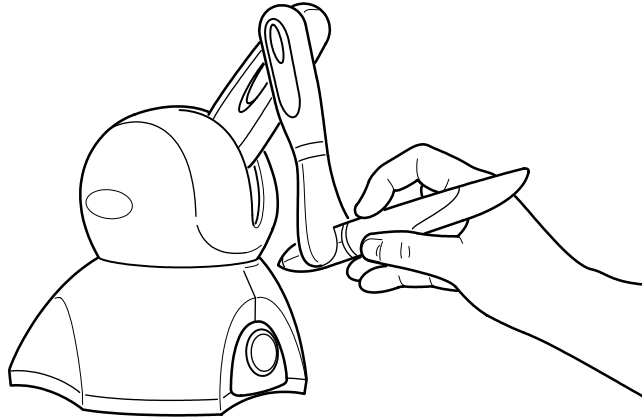

Figure B.5 — Stylus-based haptic device

## B.7 Hand-based haptic devices

Hand-based haptic devices (see Figure B.6) are complex mechanical devices providing kinaesthetic feedback to one or more finger. They differ in functionality and complexity in regard to the degrees-of-freedom available for each finger and the absolute number of fingers with kinaesthetic feedback. Due to their weight resulting from the mechanical setup, they are sometimes combined with additional point-based haptic devices, which compensate for the mechanical load on the user.

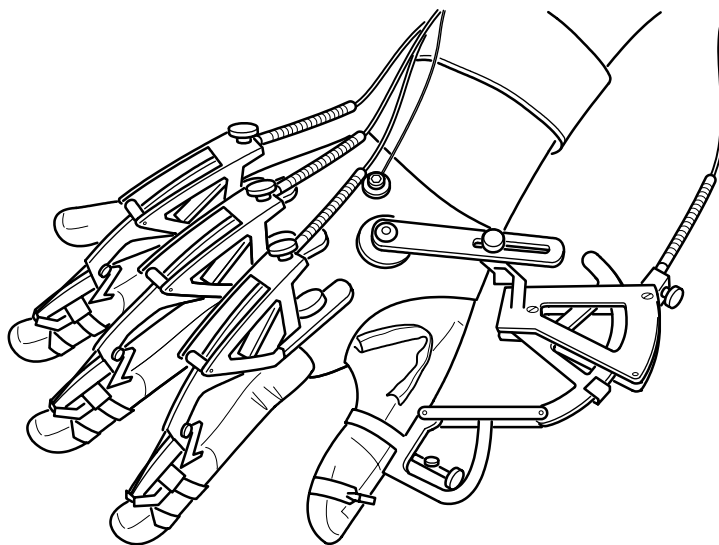

Figure B.6 — Hand-based haptic device

## B.8 Mouse that provides force feedback

A mouse that provides force feedback (see Figure B.7) is a device which adds kinaesthetic feedback to the two-dimensional movement of a computer mouse on a surface. Actuators are included which typically hinder movement during interaction. Possible applications for this function include the impact of a cursor on buttons or other areas of specific functionality within a computer program. However, variants of this type of mouse exist with active kinaesthetic properties including a vibratory element or a tactile pin matrix.

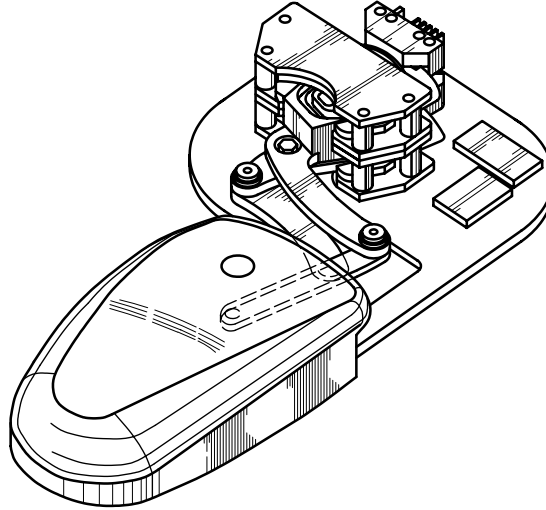

Figure B.7 — Mouse that provides force feedback

## Annex C (informative)

### Physiology of haptics

#### C.1 Somatosensory system

Both touch and kinaesthesia are part of the somatosensory system of the human body. This system includes sensory receptors in the skin and epithelia, skeletal muscles, bones and joints, internal organs and the cardiovascular system. Sensors in the muscles and joints give rise to the kinaesthetic sense, while those in the skin produce the sense commonly referred to as *touch*. In medical terms, these are referred to collectively as “somatic senses”.

Skin sensors include thermoreceptors, mechanoreceptors, chemoreceptors and nociceptors (bare nerve endings that are sensitive to pain, see C.2.4). Nerves are routed from the various sensors through the spinal cord to the parietal lobe in the cerebral cortex of the brain (see Figure C.1). A fold in the parietal lobe, the “post-central gyrus”, contains an area on the surface of the brain that maps to skin sensors all over the body. This area is the primary somatosensory area, and it takes the shape of a distorted human figure known as the “sensor homunculus”. The figure has enlarged hands and lips and a shrunken torso, in proportion to the density of skin sensors in those areas of the human body. This area is essential in the creation of a person’s body image.

A similar brain area is the nearby (anterior to the somatosensory cortex) somatomotor cortex. It controls the voluntary muscles of the body. It also has a “motor homunculus”, although points in this brain area are connected to groups of muscles rather than individual muscles. The somatomotor and somatosensory cortices work closely to coordinate body movements.

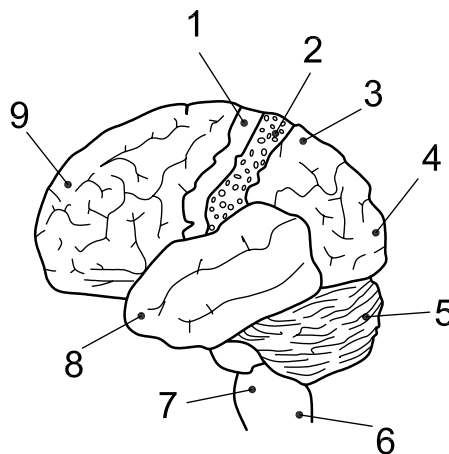

**Key**

- |                        |                     |
|------------------------|---------------------|
| 1 somatomotor cortex   | 6 spinal cord       |
| 2 somatosensory cortex | 7 medulla oblongata |
| 3 parietal lobe        | 8 temporal lobe     |
| 4 occipital lobe       | 9 frontal lobe      |
| 5 cerebellum           |                     |

**Figure C.1 — Lobes of the cerebrum**

## C.2 Touch sensors

### C.2.1 General

All haptic contact is made through the skin. Hence the physiology of touch is basic to the study of haptics.

### C.2.2 Mechanoreceptors

Four basic types of mechanoreceptor are responsible for sensing mechanical touch to the surface of “glabrous” skin — skin that does not have hair follicles.

- a) Meissner corpuscles sense the lightest touch at frequencies below 50 Hz. They discharge at the onset of a stimulus, and so are good at sensing velocity of a touch. These sensors comprise 40 % of the hand tactile receptors, lying just below the epidermis. They move with the ridges of the skin, and are therefore sensitive to movement across the skin. Their spatial resolution is 3 mm to 5 mm.
- b) Merkel discs are sensitive to skin curvature and pressure on the skin. They are slow-acting receptors, responding to stimuli up to 10 Hz. They comprise 25 % of the receptors in the hand. Their spatial resolution is about 0,5 mm.
- c) Pacinian corpuscles are sensitive to fast, light touching. Their frequency range is 100 Hz to 300 Hz, although rates to 1 kHz have been observed. These receptors are bulbs about 1 mm long, situated deep within the skin tissue. They represent 13 % of the receptors in the hand, and have a spatial resolution of about 20 mm.
- d) Ruffini endings are sensitive to static skin stretching at frequencies up to 10 Hz. These spindle-shaped receptors contribute to the kinaesthetic sense and control of finger position and movement. They make up about 19 % of hand receptors and have a spatial resolution of 10 mm.

All four types of receptors work together to give rise to the tactile sense. In addition, the following two other receptor types are active.

- e) Hair follicles are sensitive to motion of the hairs on the skin, caused by air movement or close contact.
- f) Free nerve endings (as opposed to the encapsulated endings of the four main skin touch sensors) are sensitive to pain. Varieties of free nerve endings also sense pressure on the skin, skin stretch and skin temperature. Free nerve endings can also be classified as slowly adapting, intermediate adapting and rapidly adapting.

### C.2.3 Thermoreceptors

Two basic types of thermo-receptor are found in the skin.

- a) Cold thermoreceptors are located in or just below the epidermis. They are also found in the cornea, tongue and bladder. The density of these receptors in the hand is 1 to 5 receptors per square centimetre. They give rise to feelings of cooling, cold and freshness.
- b) Warmth thermoreceptors are located in the dermis (lower down in the skin). They have a density of only 0,4 receptors per square centimetre.

### C.2.4 Nociceptors

Intense mechanical, thermal or chemical stimuli give rise to sensations of pain. The sensors involved are nociceptors, which are specialized types of free nerve endings. Their spatial resolution is about 5 mm. These sensors are connected to the brain by fast response nerves.

Nociceptor information is processed in the cerebral cortex of the brain, where pain is then consciously realized. The brain can choose to reduce the sensation of pain by requesting the release of specific hormones.

Nociceptors can also become oversensitized by inflammation in surrounding tissues. This condition of sensing pain from normal stimuli ("hyperalgesia") normally decreases when the inflammation goes down. Repeated injury can give rise to allodynia, in which light touch causes extreme pain.

### C.2.5 Chemoreceptors

Chemosensors are found primarily in internal organs, where they fulfil different functions.

- a) In the brainstem and aorta, they monitor carbon dioxide levels in the blood. Breathing and heart beat rates are increased in response to an increase in blood CO<sub>2</sub> levels.
- b) On the tongue, they form the active sensor in the five different taste buds. These buds respond to salty, sour, sweet, bitter and savoury stimuli.
- c) In the nose, chemoreceptors detect specific airborne molecules by chemical binding. They are connected to different olfactory sensory neurons. Some 40 million such neurons exist in the olfactory bulb inside the human nose.

### C.2.6 Electro-tactile stimulation

Specific receptors for electro-tactile displays have not been found, but it is thought that small electrical currents stimulate the neurons that carry information from the mechanoreceptors to the brain.

There is some research attempting to map images or sound to arrays of such stimulators to allow a blind or deaf person to perceive sight or sound by means of the haptic sense.

The sensation threshold is approximately 1 mA for a 0,1 ms pulse from a 24 mm<sup>2</sup> electrode on most body sites. The threshold decreases as electrode size increases.

The maximum current is limited by painful sensations that start at 2 to 10 times the threshold. The exact value depends on skin location, the electrode-skin contact and the sensitivity of the subject.

One tactile device matches the pattern of an array of electrical stimulators to the edges of the image captured by a video camera mounted on the subject's forehead. The stimulator part of the device is to be put into contact with the tongue, rather than the fingertips, abdomen or back. The tongue can be stimulated by only 5 V to 15 V, rather than 40 V to 500 V as for other skin areas. The tongue has nerves closer to the surface; it has no dead skin layer; it has saliva that increases electrical contact. Moreover, the area of the cerebral cortex that interprets touch from the tongue is larger than areas that serve other body parts.

.....

## C.3 Kinaesthetic sensors

### C.3.1 General

The kinaesthetic sense makes a person aware of how fast his or her limbs are moving and in what direction. It also allows a person to distinguish whether a movement is voluntary or externally imposed.

### C.3.2 Kinaesthetic receptors

Four basic types of mechanoreceptor are responsible for the kinaesthetic sense, as follows.

- a) Golgi tendon organs are found at the connection points between muscles and tendons. They are composed of lengths of collagen that are attached at one end to the muscle and at the other end to the tendon. Nerves within the organ sense the amount of stretching and hence the force being delivered by the muscle.
- b) Muscle spindles are located between individual fibres throughout the muscle. They embody several muscle fibres, along with sensors that detect changes in muscle length. Information on the length of distinct groups of muscle fibres is used to regulate stretching throughout a muscle. It also is used as part of a sensory system to determine the relative position of limbs.
- c) Pacinian corpuscles are situated near ligaments in the skeletal joints of the body. Also called Golgi endings, these sensors are most active at extreme joint positions. They are thus considered to be protective sensors.
- d) Ruffini endings also exist near skeletal joints. They are active during both static and dynamic motion, and can assist in determining joint angle with a specificity of about  $2^\circ$ .

In addition, free nerve endings are thought to play a role in the kinaesthetic sense, especially in nociceptor sensing.

### C.3.3 Just noticeable difference (JND)

The limb angles are sensed with greatest accuracy close to the body and with decreasing accuracy toward the outer (distal) parts of the limbs.

The JND for the shoulder is  $0,8^\circ$ ; for the elbow and wrist, it is  $2,0^\circ$ ; for the finger it is  $2,5^\circ$ . The JND for the hip is  $0,2^\circ$ , while for the toe it is just over  $6,0^\circ$ .

There is a difference between just noticeable difference (JND) and noticing the direction of a movement. The fact that a movement has occurred will normally be apparent to the subject before any recognition of the direction of movement.

### C.3.4 Kinaesthetic sense

The kinaesthetic sense is an overall perception of the movement and placement of a person's limbs and other body parts. It involves not only the kinaesthetic receptors in the muscles and joints, but also a body image that is set up in the brain.

A study of this sense can be organized into the following four categories.

- a) Joint angles are measured by the four types of sensor listed under "kinaesthetic sensors". These determine arm and body positions mainly by sensing muscle tension.
- b) Limb direction refers to the overall orientation of a limb with respect to the body of an individual.
- c) Body position is the orientation of the whole body with respect to its environment. This sense relies on visual cues of one's surroundings, along with input from the vestibular system — the balance mechanism that is located in the inner ear.
- d) Body force and torque is the output of the muscles when reacting with the environment by means of physical contact. The primary sensing is through kinaesthetic and mechanoreceptors.

These categories are set out in sequence from the locality of a limb to the overall body interaction with the environment. They are derived from maps of the body and its locale formed in different areas of the brain — the somatosensory cortex and the frontal lobe, among others. The "body image", or self-awareness of a person's own body and limb positions and appearance, might be a product of the brain in its entirety.

A special case of body position is balance, which is an element of proprioception. Balance is the ability to maintain one's centre of gravity within the base of support with minimal swaying in posture. It relies on the integration of inputs from several sources — the vestibular system, the somatosensory system of muscle and joint sensing, and the motor system that controls muscle action.

## C.4 Sensory-motor control

The haptic and kinaesthetic senses work together with muscle groups to allow active haptic exploration or manipulation. Exploration is dominated by the sensory channel, while manipulation of an object is dominated by the motor channel.

The coordinated motion of haptic sense and motor control represents complex action that people normally take for granted. In rare cases, if the kinaesthetic sense is destroyed or interrupted, walking and handling objects can be carried out only with the greatest of difficulty using visual clues.

A simplified model of sensory-motor control is shown in Figure C.2. In normal operation, voluntary motion planning begins in the frontal lobe. Here, the premotor cortex and the supplementary motor area evaluate input from the parietal lobe and other locations in the brain. Such input includes a sense of the body's position in space and memories of past actions, coordinated with input from the visual cortex. The primary motor cortex then determines which muscles need to contract and by how much.

Sense signals from the muscles indicate the limb and body positions at all times. These are processed in the primary motor cortex, which uses the feedback to fine-tune the motions. At the same time, the cerebellum, a lower part of the brain, adds rhythm and corrects the balance. It might act in tandem with music processed by the temporal lobe, with assistance from the basal ganglia in setting tempo and metre.

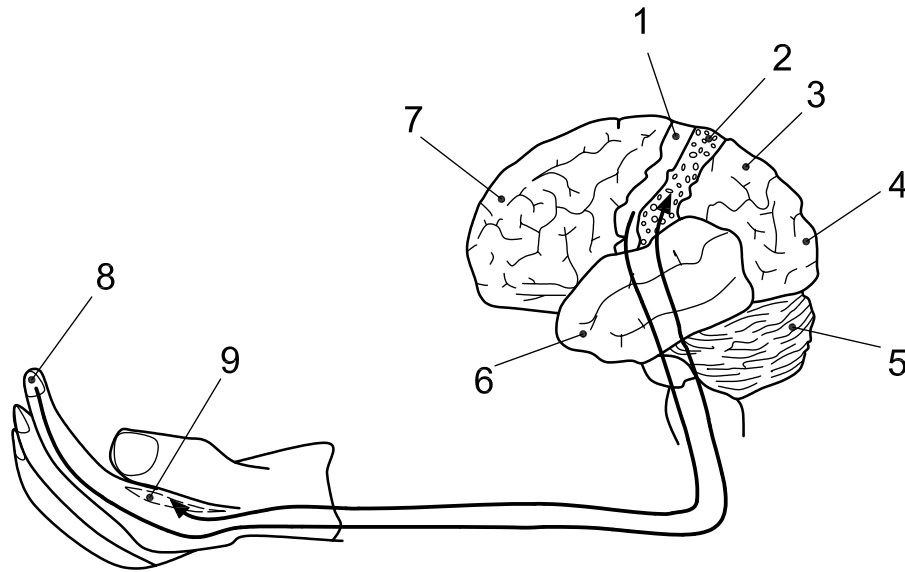

**Key**

1	somatomotor cortex	6	temporal lobe
2	somatosensory cortex	7	frontal lobe
3	parietal lobe	8	touch sensor
4	occipital lobe	9	muscle
5	cerebellum		

**Figure C.2 — Brain functioning during dance movements**

Although we can draw simple models of the brain, its operation is much more complex than these models suggest. For example, personal attributes are likely distributed widely over the brain.

Nevertheless, we can point out the operation of major sections of the brain:

- a) frontal lobe: planning, self-control and higher-level processing;
- b) posterior frontal lobe: motor movements, spatial skill;
- c) temporal lobe: hearing and memory;
- d) occipital lobe: vision;
- e) cerebellum: emotions, planning of movements.

## Bibliography

- [1] ISO 1503, *Spatial orientation and direction of movement — Ergonomic requirements*
- [2] ISO 9241-5, *Ergonomic requirements for office work with visual display terminals (VDTs) — Part 5: Workstation layout and postural requirements*
- [3] ISO 9241-12, *Ergonomic requirements for office work with visual display terminals (VDTs) — Part 12: Presentation of information*
- [4] ISO 9241-14, *Ergonomic requirements for office work with visual display terminals (VDTs) — Part 14: Menu dialogues*
- [5] ISO 9241-15, *Ergonomic requirements for office work with visual display terminals (VDTs) — Part 15: Command dialogues*
- [6] ISO 9241-16, *Ergonomic requirements for office work with visual display terminals (VDTs) — Part 16: Direct manipulation dialogues*
- [7] ISO 9241-17, *Ergonomic requirements for office work with visual display terminals (VDTs) — Part 17: Form filling dialogues*
- [8] ISO 9241-110, *Ergonomics of human-system interaction — Part 110: Dialogue principles*
- [9] ISO 9241-210, *Ergonomics of human-system interaction — Part 210: Human-centred design for interactive systems*
- [10] ISO 9241-400, *Ergonomics of human-system interaction — Part 400: Principles and requirements for physical input devices*
- [11] ISO 9241-410, *Ergonomics of human-system interaction — Part 410: Design criteria for physical input devices*
- [12] ISO 9241-920:2009, *Ergonomics of human-system interaction — Part 920: Guidance on tactile and haptic interactions*
- [13] ISO 11064-4, *Ergonomic design of control centres — Part 4: Layout and dimensions of workstations*
- [14] EN 894-4, *Safety of machinery — Ergonomic requirements for the design of displays and control actuators — Part 4: Location and arrangement of displays and control actuators*
- [15] AKAMATSU, M., MACKENZIE, I.S. and HASBROUQ, T. A comparison of tactile, auditory, and visual feedback in a pointing task using a mouse-type device. *Ergonomics*, 38, pp. 816-827
- [16] AMIRABDOLLAHIAN, F., TOPPING, T., DRIESSEN, B. and HARWIN, W. (2003). Upper Limb Robot Mediated Stroke Therapy — GENTLE/s Approach. *Autonomous Robots*, 15(1), pp. 35-51
- [17] BACH-Y-RITA, P. (1972). *Brain Mechanisms in Sensory Substitution*. New York: Academic Press
- [18] BACH-Y-RITA, P., KACZMAREK, K.A. and TYLER, M.E. (2003). A tongue-based tactile display for portrayal of environmental characteristics. In J. Hettinger and M. W. Haas (eds.), *Virtual and adaptive environments: Applications, implications, and human performance*. Mahwah, NJ: Erlbaum
- [19] BAILLIE, S., CROSSAN, A., BREWSTER, S.A., MELLOR, D. and REID, S. (2005). Validation of a Bovine Rectal Palpation Simulator for Training Veterinary Students. *Studies in Health Technology and Informatics*, pp. 33-36, IOS Press

- [20] BASDOGAN, C., DE, S., KIM, J., MUNIYANDI, M., KIM, H. and SRINIVASAN, M.A. (2004). Haptics in Minimally Invasive Surgery Simulation and Training. *IEEE Computer Graphics and Applications*, 24(2), pp. 56-64
- [21] BREWSTER, S.A. and KING, A. (2005). An Investigation into the Use of Tactons to Present Progress Information. *Proceedings of Interact 2005* (Rome, Italy), pp. 6-17
- [22] BURDEA, G.C. (2000). Haptic issues in virtual environments. *Proceedings of computer graphics international*, pp. 295-302
- [23] BURDEA, G. (1996). *Force and Touch Feedback for Virtual Reality*. New York: John Wiley & Sons
- [24] CHOI, S. and TAN, H.Z. (2004). Toward realistic haptic rendering of surface textures, *IEEE Computer Graphics and Applications*, 24(2), pp. 40-47
- [25] COCKBURN, A. and BREWSTER, S.A. Multimodal feedback for the acquisition of small targets. *Ergonomics*, 48 (9), pp. 1129-1150
- [26] COLGATE, J.E. and SCHENKEL, G.G. (1997). Passivity of a class of sampled-data systems: Application to haptic interfaces. *J. of Robotic Systems*, Vol. 14, No. 1, pp. 37-47
- [27] CRAIG, J. and JOHNSON, K.O. (2000). The two-point threshold: not a measure of tactile spatial resolution. *Current Directions in Psychological Science*, 9, pp. 29-32
- [28] CROSSAN, A. and BREWSTER, S.A., REID, S. and MELLOR, D. (2002). Multi-Session VR Medical Training — The HOPS Simulator. *Proceedings of BCS HCI 2002* (London, UK), Springer, pp. 213-226
- [29] DIOLAITI, N., NIEMEYER, G., BARBAGLI, F. and SALISBURY, J.K. (2005). Stability of haptic rendering: discretization, quantization, time-delay and coulomb effects. *IEEE Trans. Robotics*, Vol. 22, No. 2, pp. 256-268
- [30] DONALD, B.R. and HENLE, F. (2002). Using haptic vector fields for animation motion control. *Proc. 2000 IEEE Int. Conf. on Robotics & Automation*, April 2000, San Francisco, CA, pp. 3435-3442
- [31] MIRANDA, E.R. and WANDERLEY, M.M. (2006). *New Digital Musical Instruments: Control and Interaction beyond the Keyboard*. Middleton, WI: A-R Editions. ISBN 0-89579-585-X
- [32] FRISOLI, A., BERGAMASCO, M., WU, S.L. and RUFFALDI, E. (2005). Evaluation of multipoint contact interfaces in haptic perception of shapes. In F. Barbagli, D. Prattichizzo and K. Salisbury (eds.). *Multi-point Interaction with Real and Virtual Objects*, Springer Tracts in Advanced Robotics, (Vol. 18, pp. 177-188). Berlin/Heidelberg: Springer
- [33] GALLACE, A., TAN, H.Z. and SPENCE, C. (2005). Tactile change detection. In *Haptic Interfaces for Virtual Environment and Teleoperator Systems*. WHC 2005, First Joint Eurohaptics Conference and Symposium, pp. 12-16
- [34] GARROWAY, D. and HAYWARD, V. (2004). A Haptic Interface for Editing Space Trajectories. *Proc. ACM SIGGRAPH & EuroGraphics Symposium on Computer Animation*. August 27-29, Grenoble, France
- [35] GEMPERLE, F., OTA, N. and SIEWIOREK, D. (2001). Design of a Wearable Tactile Display. *Proceedings of the Fifth International Symposium on Wearable Computers*, pp. 5-12
- [36] GOSLINE, A.H.C. and HAYWARD, V. (2007). Time-Domain Passivity Control of Haptic Interfaces with Tunable Damping Hardware. *World Haptics Conference, Second Joint EuroHaptics Conference and Symposium on Haptic Interfaces for Virtual Environment and Teleoperator Systems* (WHC'07), pp. 164-179
- [37] HALE, K.S. and STANNEY, K.M. (2004). Deriving haptic design guidelines from human physiological, psychophysical and neurological foundations. *IEEE Computer Graphics and Applications*, 24(2), pp. 33-39

- [38] HAYWARD, V., ASTLEY, O.R., CRUZ-HERNANDEZ, M., GRANT, D. and ROBLES-DE-LA-TORRE, G. (2004). Haptic Interfaces and Devices. *Sensor Review*, 24(1), pp. 16-29
- [39] HAYWARD, V. and ASTLEY, O.R. (1996). Performance Measures for Haptic Interfaces. In G. Giralt and G. Hirzinger (eds.), *Robotics Research: The 7th International Symposium*. Springer Verlag, pp. 195-207
- [40] HAYWARD, V. and MACLEAN, K.E. (2007). Do It Yourself Haptics, Part-I. *IEEE Robotics and Automation Magazine*, 14(4), pp. 88-104
- [41] HO, C., SPENCE, C. and TAN, H.Z. (2005). Warning Signals Go Multisensory. *Proceedings of HCI International 2005*, Lawrence Erlbaum Associates, pp. 1-10
- [42] HOGGAN, E, BREWSTER, S.A. and JOHNSTON, J. (2008). Investigating the Effectiveness of Tactile Feedback for Mobile Touchscreens. In *Proceedings of ACM CHI 2008* (Florence, Italy). ACM Press Addison Wesley
- [43] HOLLINS, M., FALDOWSKI, R., RAO, S. and YOUNG, F. (1993). Perceptual dimensions of tactile surface texture: A multidimensional scaling analysis. *Perception and Psychophysics*, 54, pp. 697-705
- [44] HOLLIS, R. (2004). Haptics. In W. Bainbridge, ed., *Berkshire Encyclopaedia of Human-Computer Interaction*, Berkshire Publishing Group, pp. 311-316
- [45] JANSSON, G., BILLBERGER, K., PETRIE, H., COLWELL, C., KORNBROT, D., FÄNGER, J., KÖNIG, H., HARDWICK, A. and FURNER, S. (1999). Haptic virtual environments for blind people: Exploratory experiments with two devices. *International Journal of Virtual Reality*, 4, pp. 10-20
- [46] JANSSON, G. and IVAS, A. (2001). Can the efficiency of a haptic display be increased by short-time practice in exploration? In S. Brewster and R. Murray-Smith, *Haptic Human-Computer Interaction*. Heidelberg, Germany: Springer, pp. 85-91
- [47] JANSSON, G., JUSLIN, P. and POOM, L. (2006). Liquid-specific properties can be utilized for haptic perception of amount of liquid in a vessel put in motion. *Perception*, 35, pp. 1421-1432
- [48] JANSSON, G and MONACI, L. (2006). Identification of real objects under conditions similar to those in haptic displays: Providing spatially distributed information at the contact areas is more important than increasing the number of areas. *International Journal of Virtual Reality*, 9, pp. 243-249
- [49] JANSSON, G. and ÖSTRÖM, M. (2004). The effects of co-location of visual and haptic space on judgements of forms. In M. Buss & M. Fritschi (eds.), *Proceedings of the 4th International Conference Eurohaptics 2004*. Munich, Germany: Technische Universität München, pp. 516-519
- [50] JOHNSON, K.O. and PHILLIPS, J.R. (1981). Tactile spatial resolution. I. Two-point discrimination, gap detection, grating resolution, and letter recognition. *Journal of Neurophysiology*, 46(6), pp. 1177-1192
- [51] JOHNSON, K. (2002). Neural basis of haptic perception, In H. Pashler & S. Yantis, *Stevens' Handbook of Experimental Psychology, Vol. 1. Sensation and Perception* (3rd ed.). New York: Wiley, pp. 537-583
- [52] JUNGSMANN, M. (2004). Entwicklung elektrostatischer Festkörperaktoren mit elastischen Dielektrika für den Einsatz in taktilen Anzeigefeldern. Inst. für Elektromechan. Konstruktionen, Darmstadt
- [53] KACZMAREK, K., WEBSTER, J., BACH-Y-RITA, P. and TOMPKINS, W. Electrotactile and vibrotactile displays for sensory substitution systems. *IEEE Transactions on Biomedical Engineering*, 38(1), pp. 1-16
- [54] KACZMAREK, K.A., TYLER, M.E. and BACH-Y-RITA, P. (1997). Pattern identification on a fingertip-scanned electrotactile display. In Engineering in Medicine and Biology society, 1997. *Proceedings of the 19th Annual International Conference of the IEEE 4*. Vol. 4, pp. 1694-1696

- [55] KATZ, D. (1989). *The world of touch*. (Original work published 1925, Translated by L.E. Kreuger). Hillsdale, NJ: Erlbaum
- [56] KLATZKY, R.L. and LEDERMAN, S.J. (1995). Identifying objects from a haptic glance. *Perception and Psychophysics*, 57, pp. 1111-1123
- [57] KLATZKY, R.L. and LEDERMAN, S.J. (2006). The perceived roughness of resistive virtual textures: I. Rendering by a force feedback mouse. *ACM Transactions on Applied Perception*, 3, pp. 1-14
- [58] KLATZKY, R.L. and LEDERMAN, S.J. (2002). Touch. In A.F. Healy and R.W. Proctor (eds.), *Experimental Psychology* (pp. 147-176), Vol. 4 in I.B. Wiener (Editor in Chief), *Handbook of Psychology*. New York: Wiley
- [59] KLATZKY, R.L., LEDERMAN, S.J., HAMILTON, C., GRINDLEY, M. and SWENDSEN, R.H. (2003). Feeling textures through a probe: Effects of probe and surface geometry and exploratory factors. *Perception and Psychophysics*, 65, pp. 613-631
- [60] KLATZKY, R.L., LEDERMAN, S.J. and METZGER, V.A. (1985). Identifying objects by touch: An "expert system". *Perception and Psychophysics*, 37, pp. 299-302
- [61] KYUNG, K.U, AHN, M., KWON, D.S. and SRINIVASAN, M.A. (2005). Perceptual and Biomechanical Frequency Response of Human Skin: Implication for Design of Tactile Displays. *Proc. of World Haptics: 1st Joint Eurohaptics Conf. and Symposium on Haptic Interfaces for Virtual Environment and Teleoperator Systems*, Pisa, Italy, pp. 96-101
- [62] KYUNG, K.U, LEE, J.Y and PARK, J. (2008). Haptic Stylus and Empirical Studies on Braille, Button and Texture Display, *Journal of Biomedicine and Biotechnology*, ID369651
- [63] KYUNG, K.U, KIM, S.C. and KWON, D.S. (2007). Texture Display Mouse: Vibrotactile Pattern and Roughness Display, *IEEE/ASME Transactions on Mechatronics*, 12(3), pp. 356-360
- [64] LEDERMAN, S.J. and KLATZKY, R.L. (1987). Hand movements: A window into haptic object recognition. *Cognitive Psychology*, 19, pp. 342-368
- [65] LEDERMAN, S.J. and KLATZKY, R.L. (1999). Sensing and displaying spatially distributed fingertip forces in haptic interfaces for teleoperators and virtual environment systems. *Presence*, 8, pp. 86-103
- [66] LEDERMAN, S.J. and KLATZKY, R.L. (2004). Haptic identification of common objects: Effects of constraining the manual exploration process. *Perception and Psychophysics*, Vol. 66, pp. 618-628
- [67] LEDERMAN, S.J. and KLATZKY, R.L. (2004). Multisensory texture perception. In G.A. Calvert, C. Spence and B.E. Stein (eds.), *Handbook of multisensory processes*. Cambridge, MA: MIT Press, pp. 107-122
- [68] LEVESQUE, V., PASQUERO, J. and HAYWARD, V. (2007). Braille Display by Lateral Skin Deformation with the STRess2 Tactile Transducer. In *World Haptics 2007, Second Joint EuroHaptics Conference and Symposium on Haptic Interfaces for Virtual Environment and Teleoperator Systems*, pp. 115-120
- [69] LIN, M., BAXTER, W., SCHEIB, V. and WENDT, J. (2004). Physically based virtual painting. *Commun. ACM*, 47(8), pp. 40-47
- [70] MACLEAN, J.K.E. and HAYWARD, V. (2008). Do It Yourself Haptics, Part II. *IEEE Robotics and Automation Magazine*, 15(1), pp. 104-119
- [71] MAGNENAT-THALMAN, N., VOLINO, P., BONANNI, U., SUMMERS, I.R., BERGAMASCO, M., SALSEDO, F. and WOLTER, F.-E. (2007). From physics-based simulation to the touch of textiles: The HAPTEX project. *International Journal of Virtual Reality*, 6, pp. 35-44

- [72] McDONNELL, K.T., QIN, H. and WLODARCZYK, R.A. (2001). Virtual clay: a real-time sculpting system with haptic toolkits. *Proceedings of the 2001 Symposium on interactive 3D Graphics I3D '01*. ACM, New York, NY, pp. 179-190
- [73] MILLER, T. and ZELEZNIK, R., (1998). An insidious haptic invasion: adding force feedback to the X desktop. *Proceedings of the 11th annual ACM symposium on User Interface Software and Technology*, (San Francisco, CA), ACM Press, pp. 59-64
- [74] MUNIR, S., TOGNETTI, L. and BOOK, W.J. (1999). Experimental evaluation of a new braking system for use in passive haptic displays. *Proc. 1999 American Control Conference*, Vol. 6, 2-4 June 1999, San Diego, CA, pp. 445-4460
- [75] OAKELY, I., MCGEE, M.R., BREWSTER, S.A. and GRAY, P.D. (2000). Putting the feel in "look and feel". *Proceedings of the ACM CHI 2000 Human Factors in Computing Systems Conference*, pp. 415-422
- [76] OAKLEY, I., BREWSTER, S.A. and GRAY, P.D. (2001). Solving multi-target haptic problems in menu interaction. In *Extended Abstracts of ACM CHI 2001* (Seattle, WA), ACM Press, pp. 357-358
- [77] PANG, X.D., TAN, H.Z. and DURLACH, N.I. (1991). Manual discrimination of force using active finger motion. *Perception and Psychophysics*, 49, pp. 531-540
- [78] ROSENBERG, L.B. (1995). How to assess the quality of force-feedback systems. *J. of Medicine and Virtual Reality*, Vol. 1, Spring 1995, pp. 12-15
- [79] ROSENBERG, L.B. and ADELSTEIN, B.D. (1993). Perceptual decomposition of virtual haptic surfaces. *Proc. IEEE 1993 Symp. on Research Frontiers in Virtual Reality*, San Jose, CA, pp. 46-53
- [80] ROVERS, A.F. and VAN ESSEN, H.A. (2004). HIM: A Framework for Haptic Instant Messaging. *Extended Abstracts of CHI 2004*, ACM Press, pp. 1313-1316
- [81] RYU, J.H, KWON, D.S and HANNAFORD, B. (2004). Stable Teleoperation with Time Domain Passivity Control. *IEEE Transactions on Robotics and Automation*, 20(2), pp. 365-373
- [82] SADDIK, A.E. (2007). The potential of haptics technologies. *IEEE Instrumentation and Measurement Magazine*, 10(1), pp. 10-17
- [83] SALISBURY, K., CONTI, F. and BARBAGLI, F. (2004). Haptic rendering: Introductory concepts. *IEEE Computer Graphics and Applications*, 24(2), pp. 24-32
- [84] SRINIVASAN, M.A. and BASDOGAN, C. (1997). Haptics in virtual environments: Taxonomy, research status, and challenges. *Computers and Graphics*, 21(4), pp. 393-404
- [85] STEVENS, J.C. and PATTERSON, M.Q. (1995). Dimensions of spatial acuity in the touch sense: Changes over the life span. *Somatosensory and Motor Research*, 12, pp. 29-47
- [86] TAN, H.Z., BARBAGLI, F., SALISBURY, K., HO, C. and SPENCE, C. (2006). Force-direction discrimination is not influenced by reference force direction. *Haptics-e*, 4(1)
- [87] TURVEY, M.T. and CARELLO, C. (1995). Dynamic touch. In W. Epstein and S. Rogers (eds.), *Perception of space and motion*. San Diego, CA: Academic Press, pp. 401-490
- [88] ULLMER, B. and ISHII, H. (2000). Emerging frameworks for tangible user interfaces, *IBM Systems Journal*, 39, Numbers 3 and 4, 2000, MIT Media Laboratory
- [89] VAN ERP, J.B.F. (2005). Presenting Directions with a Vibro-Tactile Torso Display. *Ergonomics*, 48, pp. 302-313
- [90] VAN ERP, J.B.F., VAN VEEN, H.A.H.C., JANSEN, C. and DOBBINS, T. (2005). Waypoint Navigation with a Vibrotactile Waist Belt. *Transactions on Applied Perception*, 2(2), pp. 106-117

- [91] VAN ERP, J.B.F. and VAN VEEN, H.A.H.C. (2004). Vibrotactile in-vehicle navigation system. *Transportation Research Part F: Human Factors*, 7, pp. 247-256
- [92] VAN ERP, J.B.F. (2005). Vibrotactile spatial acuity on the torso: effects of location and timing parameters. In *Haptic Interfaces for Virtual Environment and Teleoperator Systems*. WHC 2005, First Joint Eurohaptics Conference and Symposium, pp. 80-85
- [93] VÖLKELE, T., WEBER, G., BAUMANN, U. (2008). Tactile Graphics Revised: The Novel Braille Dis 9000 Pin-Matrix Device with Multitouch Input. In K. Miesenberger et al. (eds.): *Proceedings of the International Conference on Computers Helping People With Special Needs (ICCHP'08)*, LNCS 5105, pp. 835-842
- [94] WALL, S.A. and BREWSTER, S. (2006). Feeling what you hear: Tactile feedback for navigation of audio graphs. *Proceedings of ACM CHI 2006* (Montreal, Canada). ACM Press Addison-Wesley, pp. 1123-1132
- [95] WINFIELD, L., GLASSMIRE, J., COLGATE, J.E. and PESHKIN, M. (2007). T-PaD: Tactile Pattern Display through Variable Friction Reduction. In *World Haptics 2007, Second Joint EuroHaptics Conference and Symposium on Haptic Interfaces for Virtual Environment and Teleoperator Systems*, pp. 421-426
- [96] YU, W. and BREWSTER, S.A. Evaluation of multimodal graphs for blind people. *Universal Access in the Information Society*, 3(2)

.....

---

---

**ICS 13.180; 35.180**

Price based on 55 pages