Aerospace — Washers, chamfered, with counterbore, for pulleys, in alloy steel and cadmium plated or in corrosion-resistant steel and passivated — Dimensions and masses

Aéronautique et espace — Rondelles chanfreinées, à chambrage, pour poulies, en acier allié, cadmiées, ou en acier résistant à la corrosion, passivées — Dimensions et masses

PDF disclaimer

This PDF file may contain embedded typefaces. In accordance with Adobe's licensing policy, this file may be printed or viewed but shall not be edited unless the typefaces which are embedded are licensed to and installed on the computer performing the editing. In downloading this file, parties accept therein the responsibility of not infringing Adobe's licensing policy. The ISO Central Secretariat accepts no liability in this area.

Adobe is a trademark of Adobe Systems Incorporated.

Details of the software products used to create this PDF file can be found in the General Info relative to the file; the PDF-creation parameters were optimized for printing. Every care has been taken to ensure that the file is suitable for use by ISO member bodies. In the unlikely event that a problem relating to it is found, please inform the Central Secretariat at the address given below.

© ISO 2002

All rights reserved. Unless otherwise specified, no part of this publication may be reproduced or utilized in any form or by any means, electronic or mechanical, including photocopying and microfilm, without permission in writing from either ISO at the address below or ISO's member body in the country of the requester.

ISO copyright office
Case postale 56 • CH-1211 Geneva 20
Tel. + 41 22 749 01 11
Fax + 41 22 749 09 47
E-mail copyright@iso.ch
Web www.iso.ch

Printed in Switzerland

Foreword

ISO (the International Organization for Standardization) is a worldwide federation of national standards bodies (ISO member bodies). The work of preparing International Standards is normally carried out through ISO technical committees. Each member body interested in a subject for which a technical committee has been established has the right to be represented on that committee. International organizations, governmental and non-governmental, in liaison with ISO, also take part in the work. ISO collaborates closely with the International Electrotechnical Commission (IEC) on all matters of electrotechnical standardization.

International Standards are drafted in accordance with the rules given in the ISO/IEC Directives, Part 3.

Draft International Standards adopted by the technical committees are circulated to the member bodies for voting. Publication as an International Standard requires approval by at least 75 % of the member bodies casting a vote.

Attention is drawn to the possibility that some of the elements of this International Standard may be the subject of patent rights. ISO shall not be held responsible for identifying any or all such patent rights.

International Standard ISO 9217 was prepared by Technical Committee ISO/TC 20, *Aircraft and space vehicles*.

Annex A forms a normative part of this International Standard.

Aerospace — Washers, chamfered, with counterbore, for pulleys, in alloy steel and cadmium plated or in corrosion-resistant steel and passivated — Dimensions and masses

1 Scope

This International Standard specifies the characteristics of chamfered washers with counterbore

- in alloy steel and cadmium plated, classification 900 MPa¹⁾/235 °C²⁾; or
- in corrosion-resistant steel and passivated, classification 900 MPa¹⁾/450 °C²⁾.

This International Standard is applicable to washers used with ISO 9219 bolts, diameter code 080 to 250, ISO 9216 nuts and ISO 1234 split pins in the assembly of ISO 7939 pulleys.

It is also applicable to washers used in the assembly of airframe rolling bearings or spherical bearings.

2 Normative references

The following normative documents contain provisions which, through reference in this text, constitute provisions of this International Standard. For dated references, subsequent amendments to, or revisions of, any of these publications do not apply. However, parties to agreements based on this International Standard are encouraged to investigate the possibility of applying the most recent editions of the normative documents indicated below. For undated references, the latest edition of the normative document referred to applies. Members of ISO and IEC maintain registers of currently valid International Standards.

ISO 1234:1997, *Split pins*

ISO 7939:1988, *Aircraft — Non-metallic pulleys with ball bearings for control cables — Dimensions and loads*

ISO 8075:1985, *Aerospace — Surface treatment of hardenable stainless steel parts*

ISO 9216:2002, *Aerospace — Nuts, hexagonal, slotted (castellated), for pulleys, in alloy steel and cadmium plated or in corrosion-resistant steel and passivated — Dimensions and masses*

ISO 9219:2002, *Aerospace — Bolts, thin hexagonal head, for pulleys, close tolerance shank, short thread, in alloy steel and cadmium plated or in titanium alloy and MoS₂ lubricated or in corrosion-resistant steel and passivated — Dimensions and masses*

ISO 13715:2000, *Technical drawings — Edges of undefined shape — Vocabulary and indications*

EN 2133:1997³⁾, *Aerospace series — Cadmium plating of steels with specified tensile strength ≤ 1 450 MPa, copper, copper alloys and nickel alloys*

1) Minimum tensile strength of the material at ambient temperature.

2) Maximum temperature, determined by the surface treatment, that the bolt can withstand without continuous change in its original characteristics after return to ambient temperature.

3) AECMA Standard.

prEN 2136:—⁴⁾, Aerospace series — Steel FE-PM42 — $900 \text{ MPa} \leq R_m \leq 1\,100 \text{ MPa}$ — Bars — $D_e \leq 100 \text{ mm}$

prEN 2205:—⁵⁾, Aerospace series — Steel FE-PL43S — $900 \text{ MPa} \leq R_m \leq 1\,100 \text{ MPa}$ — Bars — $D_e \leq 40 \text{ mm}$

prEN 2438:—⁵⁾, Aerospace series — Steel FE-PL62 — $900 \text{ MPa} \leq R_m \leq 1\,100 \text{ MPa}$ — Bars — $D_e \leq 40 \text{ mm}$

prEN 2444:—⁶⁾, Aerospace series — Steel FE-PL711 — $900 \text{ MPa} \leq R_m \leq 1\,100 \text{ MPa}$ — Bars and wires — $D_e \leq 45 \text{ mm}$

AMS-QQ-P-416A:2002, Plating, cadmium (electrodeposited)

3 Requirements

3.1 Configuration, dimensions and masses

Configuration, dimensions and masses shall be in accordance with Figure 1 and Table 1. Dimensions and tolerances are expressed in millimetres and apply after surface treatment. Surface roughness values apply before surface treatment.

Table 1 — Dimensions and masses

Dimensions in millimetres

Diameter code	D_1	D_2	D_3	D_4	E	H	Mass ^a ≈ kg/1 000 pieces
	$+0,3$ 0	$+0,3$ 0	$+0,3$ 0	0 $-0,2$			
080	8	10	6,2	13	2,5	4	2,9
100	10	13	8,2	16		4,5	4,8
120	12	15	10,2	18			5,5
150	15	18	12,2	22		5	9,3
170	17	20	14,2	24			10
200	20	23	16,5	28		5,5	14,7
220	22	25	18,5	30			16
250	25	28	20,5	34			22

^a Calculated on the basis of 7,85 kg/dm³; given for information only.

4) AECMA Standard. It has been declassified and will be replaced, at publication, by prEN 3490, Aerospace series — Steel FE-PM3901 (X15CrNi17-3) — Air melted — Hardened and tempered — $900 \text{ MPa} \leq R_m \leq 1\,100 \text{ MPa}$ — Bar for machining $D_e \leq 200 \text{ mm}$.

5) AECMA Standard to be published as a European Standard (CEN).

6) AECMA Standard. It has been declassified and will be replaced, at publication, by prEN 3513, Aerospace series — Steel FE-PL711 — Hardened and tempered — $900 \text{ MPa} \leq R_m \leq 1\,100 \text{ MPa}$ — Bar and wire — $D_e \leq 45 \text{ mm}$.

5 Marking

Marking shall be on labels and/or packaging and shall include the manufacturer's name, the quantity or mass and the identity block specified in clause 4.

Dimensions in millimetres
Surface roughness in micrometres

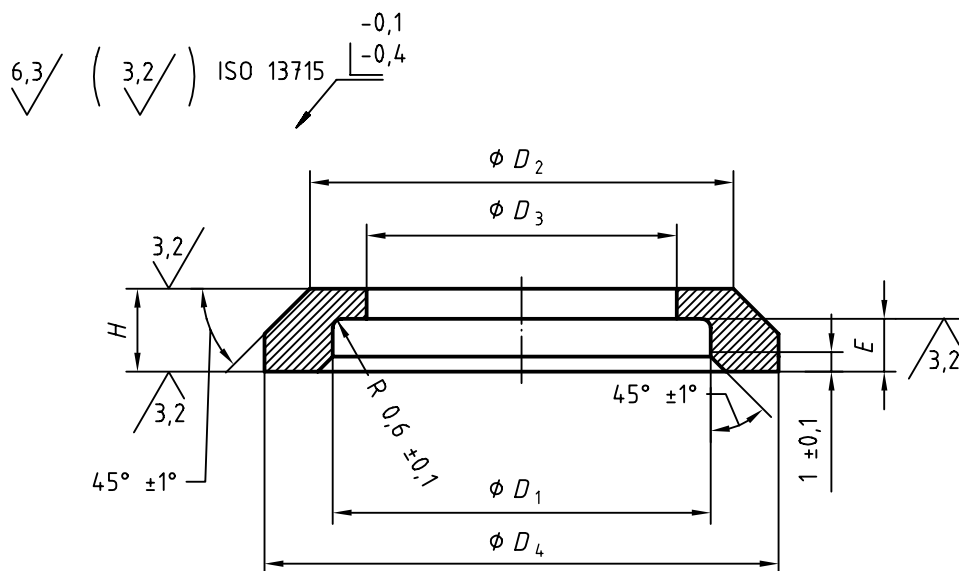

Figure 1 — Chamfered washer

Annex A (normative)

Correspondence between national standards

This annex establishes a correspondence between different materials and surface treatments standards from certain user countries. Other materials and surface treatment standards may be declared in this annex in future revisions of this International Standard.

Table A.1 — European standard

Code	Material		Surface treatment	
	Family	Standard	Type	Standard
A	Alloy steel, strength classification ≥ 900 MPa	prEN 2205 prEN 2438 prEN 2444	Cadmium plating	EN 2133
B	Corrosion-resistant steel, strength classification ≥ 900 MPa	prEN 2136	Passivation	ISO 8075

Table A.2 — Standards from other user countries

Code	Material		Surface treatment	
	Family	Standard	Type	Standard
A	Alloy steel, strength classification ≥ 900 MPa	—	Cadmium plating	AMS-QQ-P-416A
B	Corrosion-resistant steel, strength classification ≥ 900 MPa	—	Passivation	ISO 8075

ICS 49.030.50

Price based on 5 pages

© ISO 2002 – All rights reserved