**Tools for pressing — Guide pillars —
Part 3:
Type B, end-locking pillars**

*Outillage de presse — Colonnes de guidage —
Partie 3: Type B, colonnes à retenue inférieure*





COPYRIGHT PROTECTED DOCUMENT

© ISO 2013

All rights reserved. Unless otherwise specified, no part of this publication may be reproduced or utilized otherwise in any form or by any means, electronic or mechanical, including photocopying, or posting on the internet or an intranet, without prior written permission. Permission can be requested from either ISO at the address below or ISO's member body in the country of the requester.

ISO copyright office
Case postale 56 • CH-1211 Geneva 20
Tel. + 41 22 749 01 11
Fax + 41 22 749 09 47
E-mail copyright@iso.org
Web www.iso.org

Published in Switzerland

Contents

	Page
Foreword	iv
1 Scope	1
2 Normative references	1
3 Dimensions	1
4 Material	3
5 Designation	3
Bibliography	4

Foreword

ISO (the International Organization for Standardization) is a worldwide federation of national standards bodies (ISO member bodies). The work of preparing International Standards is normally carried out through ISO technical committees. Each member body interested in a subject for which a technical committee has been established has the right to be represented on that committee. International organizations, governmental and non-governmental, in liaison with ISO, also take part in the work. ISO collaborates closely with the International Electrotechnical Commission (IEC) on all matters of electrotechnical standardization.

The procedures used to develop this document and those intended for its further maintenance are described in the ISO/IEC Directives, Part 1. In particular the different approval criteria needed for the different types of ISO documents should be noted. This document was drafted in accordance with the editorial rules of the ISO/IEC Directives, Part 2 (see www.iso.org/directives).

Attention is drawn to the possibility that some of the elements of this document may be the subject of patent rights. ISO shall not be held responsible for identifying any or all such patent rights. Details of any patent rights identified during the development of the document will be in the Introduction and/or on the ISO list of patent declarations received (see www.iso.org/patents).

Any trade name used in this document is information given for the convenience of users and does not constitute an endorsement.

For an explanation on the meaning of ISO specific terms and expressions related to conformity assessment, as well as information about ISO's adherence to the WTO principles in the Technical Barriers to Trade (TBT) see the following URL: [Foreword - Supplementary information](#)

The committee responsible for this document is ISO/TC 29, *Small tools*, Subcommittee SC 8, *Tools for pressing and moulding*.

This second edition results from the reinstatement of ISO 9182-3:1992 which was withdrawn in 2007 and with which it is technically identical.

ISO 9182 consists of the following parts, under the general title *Tools for pressing — Guide pillars*:

- *Part 1: Types*
- *Part 2: Type A, straight pillars*
- *Part 3: Type B, end-locking pillars*
- *Part 4: Type C, pillars with taper lead and bush*
- *Part 5: Type D, end-locking pillars with flange*

Tools for pressing — Guide pillars —

Part 3: Type B, end-locking pillars

1 Scope

This part of ISO 9182 specifies the dimensions and tolerances, in millimetres, of guide pillars, type B, intended for use in press tools. These guide pillars can be end-locking, type B1 (see [Figure 1](#)), or end-locking with lubrication grooves, type B2 (see [Figure 2](#)).

It gives guidance on the materials and specifies the hardness and the designation of guide pillars which meet the requirements of this part of ISO 9182.

2 Normative references

The following documents, in whole or in part, are normatively referenced in this document and are indispensable for its application. For dated references, only the edition cited applies. For undated references, the latest edition of the referenced document (including any amendments) applies.

ISO 6753-1:2005, *Tools for pressing and moulding — Machined plates — Part 1: Machined plates for press tools*

ISO 9448-10:2013, *Tools for pressing — Guide bushes — Part 10: Form E, gliding bushes, flanged, type 2*

3 Dimensions

The dimensions of end-locking guide pillar (type B1) shall conform to the indications of [Figure 1](#) and [Table 1](#).

The dimensions of end-locking guide pillar with lubrication grooves (type B2) shall conform to the indications of [Figure 2](#) and [Table 1](#).

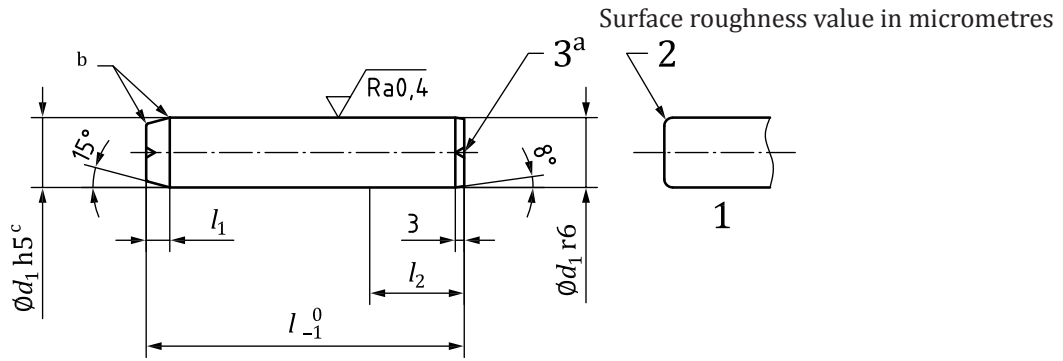

Key

- 1 alternative
- 2 radius
- 3 centres
- a Optional.
- b Slightly rounded. The values of the radii are left to the manufacturer's discretion.
- c A g6 tolerance can be applied if required for certain applications and, if so, shall be used only in conjunction with guide bush in accordance with ISO 9448-10.

Figure 1 — Type B1, end-locking guide pillar

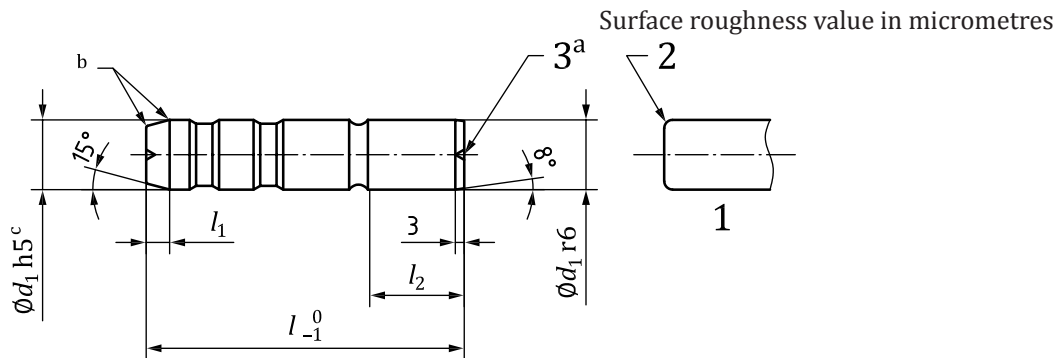

Key

- 1 alternative
- 2 radius
- 3 centres
- a Optional.
- b Slightly rounded. The values of the radii are left to the manufacturer's discretion.
- c A g6 tolerance can be applied if required for certain applications and, if so, shall be used only in conjunction with guide bush in accordance with ISO 9448-10.

Figure 2 — Type B2, end-locking guide pillar with lubrication grooves

Table 1

d_1		25	32	40	50	63	80	100
l_1 min.		6	6	6	8	8	8	8
l_2 min.		32	40	40	50	63	80	100
l_{-1}^0	125	×	×					
	140	×	×	×				
	160	×	×	×	×			
	180	×	×	×	×	×		
	200	×	×	×	×	×	×	
	224	×	×	×	×	×	×	×
	250	×	×	×	×	×	×	×
	280	×	×	×	×	×	×	×
	315		×	×	×	×	×	×
	355			×	×	×	×	×
	400			×	×	×	×	×
	450				×	×	×	×
500					×	×	×	

NOTE 1 ×, standardized dimension.

NOTE 2 Larger values of l_2 shall be chosen as a function of other dimensions such as plate thickness in accordance with ISO 6753-1.

NOTE 3 To prevent an incorrect assembly of the upper and lower plates of the die set in relation to each other, the following values of d_1 are recommended: 24, 30, 38, 48, and 60.

4 Material

The material is left to the manufacturer's discretion and the hardness shall be (60^{+2}_0) HRC.

5 Designation

Guide pillars for press tools in accordance with this part of ISO 9182 shall be designated by

- "Guide pillar";
- a reference to this part of ISO 9182, i.e. ISO 9182-3;
- its type;
- its diameter, d_1 , in millimetres, and corresponding tolerance;
- its overall length, l , in millimetres.

EXAMPLE A guide pillar, type B1, of diameter $d_1 = 25$ mm with a tolerance h5, and overall length $l = 125$ mm is designated as follows:

Guide pillar ISO 9182-3 – B1 – 25h5 × 125

Bibliography

- [1] ISO 6508-1:2005, *Metallic materials — Rockwell hardness test — Part 1: Test method (scales A, B, C, D, E, F, G, H, K, N, T)*
- [2] ISO 9182-1:2013, *Tools for pressing — Guide pillars — Part 1: Types*

