**Dentistry — Extraction forceps —
Part 3:
Design**

*Médecine bucco-dentaire — Daviers —
Partie 3: Conception*



Reference number
ISO 9173-3:2014(E)



COPYRIGHT PROTECTED DOCUMENT

© ISO 2014

All rights reserved. Unless otherwise specified, no part of this publication may be reproduced or utilized otherwise in any form or by any means, electronic or mechanical, including photocopying, or posting on the internet or an intranet, without prior written permission. Permission can be requested from either ISO at the address below or ISO's member body in the country of the requester.

ISO copyright office
Case postale 56 • CH-1211 Geneva 20
Tel. + 41 22 749 01 11
Fax + 41 22 749 09 47
E-mail copyright@iso.org
Web www.iso.org

Published in Switzerland

Contents

	Page
Foreword	iv
1 Scope	1
2 Normative references	1
3 Terms, definitions and symbols	1
3.1 Terms and definitions	1
3.2 Symbols	1
4 Classification	3
4.1 General	3
4.2 Joint design	3
4.3 Handle shape	4
4.4 Beak shape	5
5 Handle types	5
5.1 General	5
5.2 Straight handle	5
5.3 Curved handle	6
6 Intended application	8
Bibliography	9

Foreword

ISO (the International Organization for Standardization) is a worldwide federation of national standards bodies (ISO member bodies). The work of preparing International Standards is normally carried out through ISO technical committees. Each member body interested in a subject for which a technical committee has been established has the right to be represented on that committee. International organizations, governmental and non-governmental, in liaison with ISO, also take part in the work. ISO collaborates closely with the International Electrotechnical Commission (IEC) on all matters of electrotechnical standardization.

The procedures used to develop this document and those intended for its further maintenance are described in the ISO/IEC Directives, Part 1. In particular the different approval criteria needed for the different types of ISO documents should be noted. This document was drafted in accordance with the editorial rules of the ISO/IEC Directives, Part 2. www.iso.org/directives

Attention is drawn to the possibility that some of the elements of this document may be the subject of patent rights. ISO shall not be held responsible for identifying any or all such patent rights. Details of any patent rights identified during the development of the document will be in the Introduction and/or on the ISO list of patent declarations received. www.iso.org/patents

Any trade name used in this document is information given for the convenience of users and does not constitute an endorsement.

For an explanation on the meaning of ISO specific terms and expressions related to conformity assessment, as well as information about ISO's adherence to the WTO principles in the Technical Barriers to Trade (TBT) see the following URL: [Foreword - Supplementary information](#)

The committee responsible for this document is ISO/TC 106, *Dentistry*, Subcommittee SC 4, *Dental instruments*.

ISO 9173 consists of the following parts, under the general title *Dentistry — Extraction forceps*:

- *Part 1: General requirements and test methods*
- *Part 2: Designation*
- *Part 3: Design*

Dentistry — Extraction forceps —

Part 3: Design

1 Scope

This part of ISO 9173 specifies the design for extraction forceps used in dentistry.

2 Normative references

The following documents, in whole or in part, are normatively referenced in this document and are indispensable for its application. For dated references, only the edition cited applies. For undated references, the latest edition of the referenced document (including any amendments) applies.

ISO 1942, *Dentistry — Vocabulary*

ISO 9173-1, *Dentistry — Extraction forceps — Part 1: General requirements and test methods*

ISO 9173-2, *Dentistry — Extraction forceps — Part 2: Designation*

3 Terms, definitions and symbols

For the purposes of this document, the terms and definitions given in ISO 1942, ISO 9173-1, ISO 9173-2 and the following terms, definitions and symbols apply.

3.1 Terms and definitions

3.1.1 beak

<extraction forceps> functional working end of forceps which contacts the teeth

3.1.2 joint

<extraction forceps> connection point for first and second handles which are pivotally connected

3.1.3 handle

<extraction forceps> part which is held in the hand

3.2 Symbols

b_1	beak thickness
b_2	crown space width
b_3	beak separation
b_4	beak width (combined)
h_1	beak offset 1
h_2	beak offset 2

- l_1 overall forceps length
- l_2 overall beak length
- l_3 working length of beak

The dimensions are shown in [Figure 1](#). The indication of measurement points with forceps closed is presented in [Table 1](#).

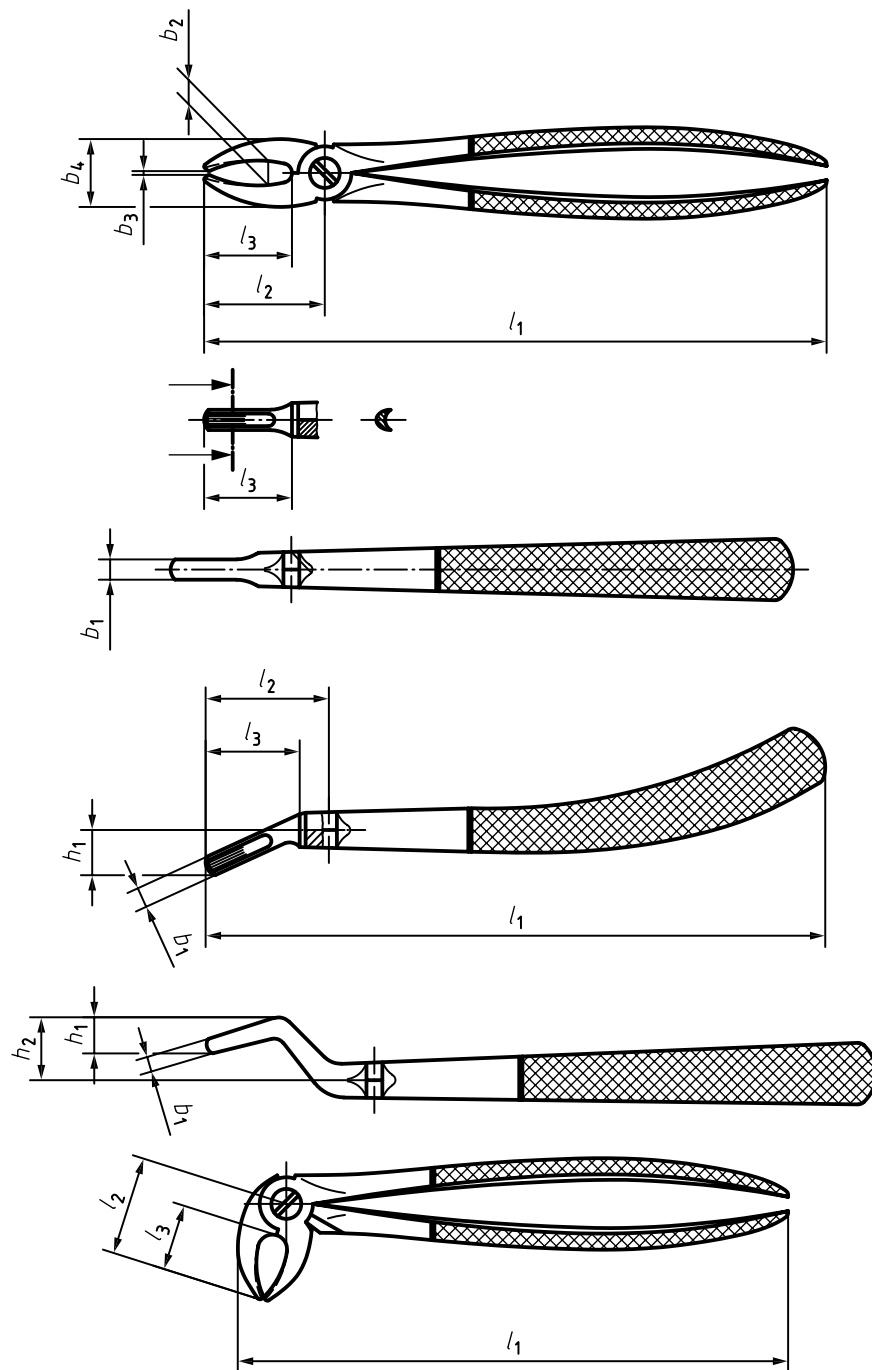

Figure 1 — Extraction forceps dimensions

Table 1 — Indication of measurement points with forceps closed

Symbol	Dimension	Measurement point
b_1	Beak thickness	At the beak grip
b_2	Crown space width	At maximum width
b_3	Beak separation	At minimum gap
b_4	Beak width (combined)	At maximum distance across both beaks
h_1	Beak offset 1	If $h_2 = 0$, from furthest point of beak tip to centreline of forceps If $h_2 \neq 0$, from furthest point of beak tip to furthest point of first bend
h_2	Beak offset 2	From centreline of forceps to furthest point of first bend
l_1	Overall forceps length	From beak tip to end of handle
l_2	Overall beak length	From beak tip to pivot centre
l_3	Working length of beak	From beak tip to outside of the joint

4 Classification

4.1 General

Extraction forceps are used together with dental elevators (see ISO 15087)^[1] to extract teeth. Each extraction forceps is classified by a series of features that describe the beak, joint and handle shape.

4.2 Joint design

The joints of extraction forceps are classified into the following types:

- circular joint (see [Figure 2](#));
- lap joint (see [Figure 3](#));
- box lock Type 1 (see [Figure 4](#));
- box lock Type 2 (see [Figure 5](#)).

Extraction forceps shall have joints allowing the extraction forceps to move freely.

For circular joints the usage of a PTFE (poly tetra fluor ethylene) sheet is recommended.

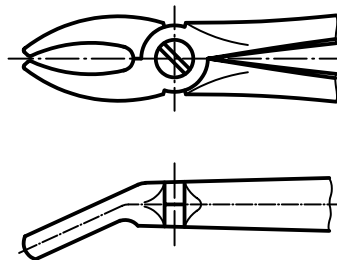

Figure 2 — Circular joint

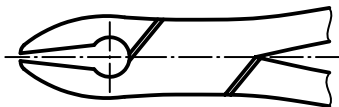

Figure 3 — Lap joint

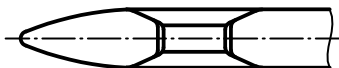
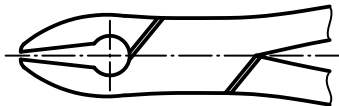

Figure 4 — Box lock Type 1

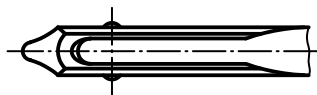
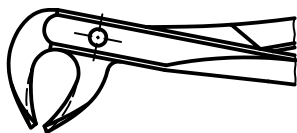

Figure 5 — Box lock Type 2

4.3 Handle shape

The handles of extraction forceps are classified into the following types:

- straight handle;
- curved handle;
- multiple curved handle.

4.4 Beak shape

The beaks of extraction forceps are classified according to their inner areas into the following types:

- a)
 - coated;
 - non-coated,
- b)
 - smooth;
 - serrated.

The beaks are designed to fit around the cervical portion of the tooth, i.e. around the curve of the tooth's crown. Pointed beaks are designed to grip the furcation area.

Universal forceps have a beak that can be used in any quadrant of the mouth.

Extraction forceps designed for multi-rooted teeth have beaks with a point that is adapted to grip the tooth furcation.

5 Handle types

5.1 General

The shape of the handle is left to the discretion of the manufacturer.

The surface profile of the handle shall be designed according to the choice of the manufacturer. The knurled handle such as that shown in [Figure 6](#) is given by way of example only. Other handle designs such as the one shown in [Figure 8](#) (e.g. with indentations, anatomical) are also acceptable.

The surface of the handle shall be easy to clean.

The following handle designs are given as examples:

- a) a knurled handle allows the operator to have a better grip.
- b) a palm grasp is used with the handle of the extraction forceps.
- c) a curve on the end of the handle can be present for the little finger, to provide more stability and leverage.
- d) maxillary forceps have a handle which is often curved upwards, with the beak in line with the handle.
- e) mandibular forceps have a straight handle with the beak at a 90° angle to the handle.

5.2 Straight handle

5.2.1 Straight handle Type 1

See [Figure 6](#).

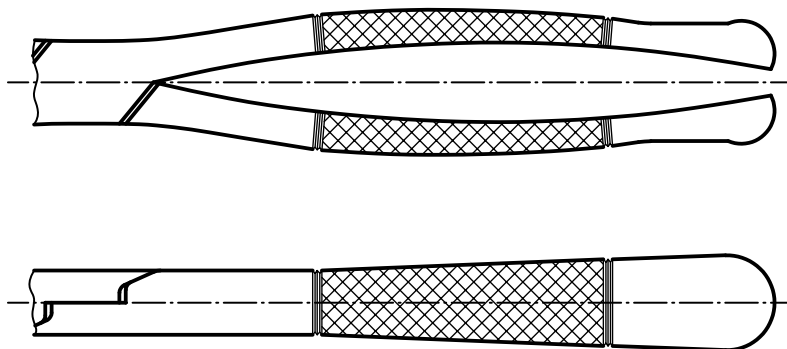

Figure 6 — Straight handle Type 1

5.2.2 Straight handle Type 2

See [Figure 7](#).

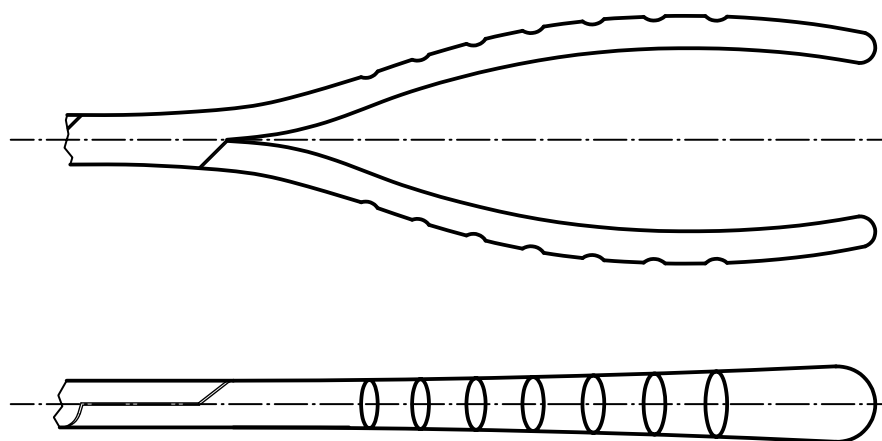

Figure 7 — Straight handle Type 2

5.3 Curved handle

5.3.1 Curved handle Type 1

See [Figure 8](#).

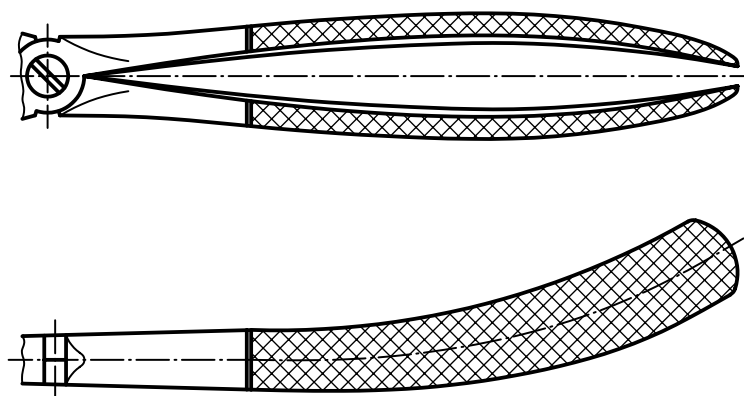
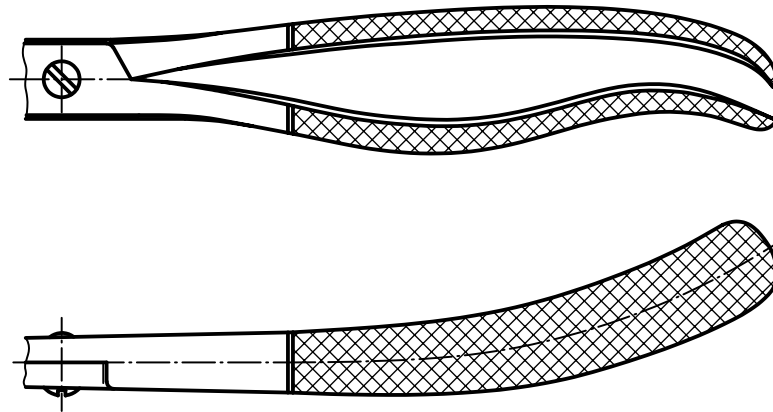

Figure 8 — Curved handle Type 1

5.3.2 Curved handle Type 2

See [Figure 9](#).



NOTE This type of handle is also known as a Read pattern handle.

Figure 9 — Curved handle Type 2

5.3.3 Curved handle Type 3

See [Figure 10](#).

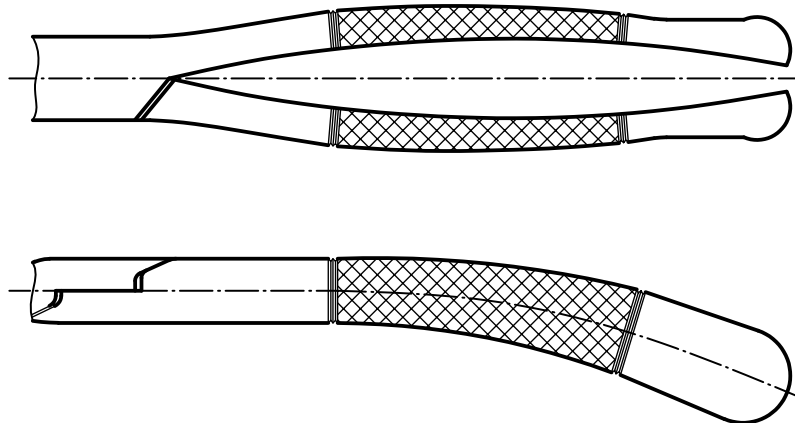

Figure 10 — Curved handle Type 3

5.3.4 Curved handle Type 4

See [Figure 11](#).

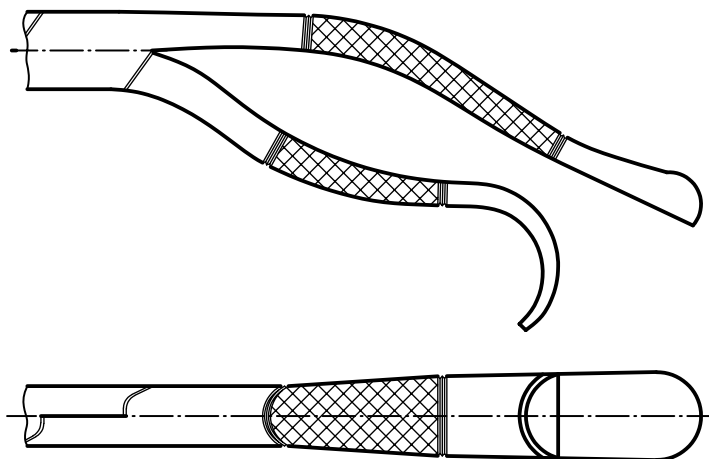

Figure 11 — Curved handle Type 4

6 Intended application

The combination of the different designs for beak, joint and handle results in a specific extraction forceps with an intended application. The manufacturer shall indicate the intended application of the extraction forceps in accordance with ISO 9173-2.

The usage of extraction forceps is subdivided into application for adults and for children (smaller forceps). A further design specification is the intended application to specific areas of the oral region or teeth as given in ISO 9173-2.

Bibliography

- [1] ISO 15087 (all parts), *Dental elevators*

© ISO 2014. All rights reserved.

ICS 11.060.20

Price based on 9 pages