Dentistry — Extraction forceps —
Part 1:
General requirements

Médecine bucco-dentaire — Daviers —
Partie 1: Exigences générales



COPYRIGHT PROTECTED DOCUMENT

© ISO 2016, Published in Switzerland

All rights reserved. Unless otherwise specified, no part of this publication may be reproduced or utilized otherwise in any form or by any means, electronic or mechanical, including photocopying, or posting on the internet or an intranet, without prior written permission. Permission can be requested from either ISO at the address below or ISO's member body in the country of the requester.

ISO copyright office
Ch. de Blandonnet 8 • CP 401
CH-1214 Vernier, Geneva, Switzerland
Tel. +41 22 749 01 11
Fax +41 22 749 09 47
copyright@iso.org
www.iso.org

Contents

Page

Foreword	iv
Introduction	v
1 Scope	1
2 Normative references	1
3 Terms and definitions	1
4 Requirements	2
4.1 Materials.....	2
4.1.1 Component parts and fastening components.....	2
4.2 Maximum overall length.....	2
4.3 Rockwell hardness.....	2
4.4 Surface finish.....	2
4.4.1 All surfaces.....	2
4.4.2 Beaks.....	3
4.5 Resistance to reprocessing.....	3
4.6 Joint opening/closing force.....	3
4.7 Joint movement.....	3
5 Test methods	3
5.1 Visual inspection.....	3
5.2 Resistance to reprocessing.....	3
5.3 Joint opening/closing force.....	3
5.4 Joint movement.....	3
6 Marking	4
Bibliography	5

Foreword

ISO (the International Organization for Standardization) is a worldwide federation of national standards bodies (ISO member bodies). The work of preparing International Standards is normally carried out through ISO technical committees. Each member body interested in a subject for which a technical committee has been established has the right to be represented on that committee. International organizations, governmental and non-governmental, in liaison with ISO, also take part in the work. ISO collaborates closely with the International Electrotechnical Commission (IEC) on all matters of electrotechnical standardization.

The procedures used to develop this document and those intended for its further maintenance are described in the ISO/IEC Directives, Part 1. In particular the different approval criteria needed for the different types of ISO documents should be noted. This document was drafted in accordance with the editorial rules of the ISO/IEC Directives, Part 2 (see www.iso.org/directives).

Attention is drawn to the possibility that some of the elements of this document may be the subject of patent rights. ISO shall not be held responsible for identifying any or all such patent rights. Details of any patent rights identified during the development of the document will be in the Introduction and/or on the ISO list of patent declarations received (see www.iso.org/patents).

Any trade name used in this document is information given for the convenience of users and does not constitute an endorsement.

For an explanation on the meaning of ISO specific terms and expressions related to conformity assessment, as well as information about ISO's adherence to the World Trade Organization (WTO) principles in the Technical Barriers to Trade (TBT) see the following URL: www.iso.org/iso/foreword.html.

The committee responsible for this document is ISO/TC 106, *Dentistry*, Subcommittee SC 4, *Dental instruments*.

This third edition cancels and replaces the second edition (ISO 9173-1:2006), which has been technically revised with the following changes:

- a) as reprocessing test, only the autoclave test was selected;
- b) the reprocessing cycles were increased to 100 cycles;
- c) the boiling water test was deleted.

ISO 9173 consists of the following parts, under the general title *Dentistry — Extraction forceps*:

- *Part 1: General requirements*
- *Part 2: Designation*
- *Part 3: Design*

Introduction

This revision of ISO 9173-1 is intended to cover all extraction forceps used in dentistry.

Dentistry — Extraction forceps —

Part 1: General requirements

1 Scope

This part of ISO 9173 specifies the general performance requirements for extraction forceps used in dentistry.

2 Normative references

The following documents, in whole or in part, are normatively referenced in this document and are indispensable for its application. For dated references, only the edition cited applies. For undated references, the latest edition of the referenced document (including any amendments) applies.

ISO 1942, *Dentistry — Vocabulary*

ISO 6508-1, *Metallic materials — Rockwell hardness test — Part 1: Test method (scales A, B, C, D, E, F, G, H, K, N, T)*

ISO 17664, *Sterilization of medical devices — Information to be provided by the manufacturer for the processing of resterilizable medical devices*

3 Terms and definitions

For the purposes of this document, the terms and definitions given in ISO 1942 and the following apply.

3.1

extraction forceps

type of pincers used for the extraction of teeth

3.2

beak

functional working end of forceps which enclose the teeth

3.3

facial beak

beak that is designed to be in contact with the facial surface of the tooth

3.4

lingual beak

beak that is designed to be in contact with the lingual surface of the tooth

3.5

beak separation

minimum gap between beak tips with the extraction forceps closed

3.6

overall beak length

distance from beak tip to pivot centre

3.7 fastening components

component of the extraction forceps used for fastening the pincers

EXAMPLE Pins, rivets and screws.

4 Requirements

4.1 Materials

4.1.1 Component parts and fastening components

All stainless steel components shall conform to the requirements of 4.2 to 4.6. Examples of suitable stainless steels can be found in ISO 7153-1.

4.2 Maximum overall length

The maximum overall length of extraction forceps shall not exceed 200 mm.

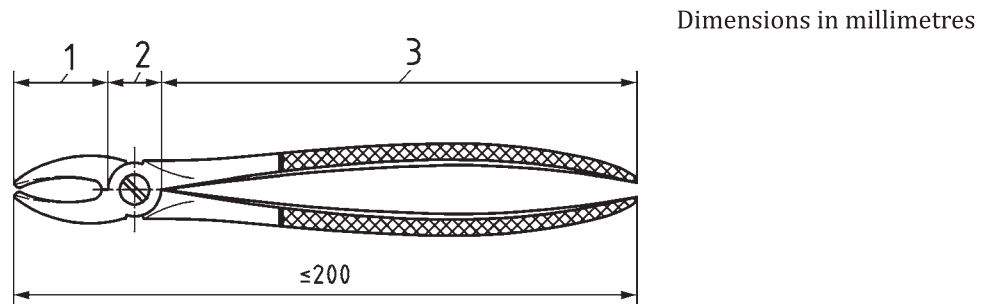

Key

- 1 beak
- 2 joint
- 3 handle

Figure 1 — General description of extraction forceps

4.3 Rockwell hardness

The component parts of the extraction forceps, with the exception of the fastening components, shall be heat treated to attain a Rockwell hardness value of 40 HRC to 52 HRC when determined in accordance with ISO 6508-1.

Mating surfaces on the same extraction forceps, such as those on opposite beaks, shall not vary in hardness by more than 3 units on the Rockwell hardness scale C.

4.4 Surface finish

4.4.1 All surfaces

All surfaces shall be free from surface defects and residues and shall also be free from any non-functional sharp edges, including burrs or flash.

Test in accordance with 5.1.

4.4.2 Beaks

When the inner or crown space of the extraction forceps is serrated or textured, the serration or texture shall be consistent within any one pattern of extraction forceps.

Test in accordance with [5.1](#).

4.5 Resistance to reprocessing

The extraction forceps shall show no evidence of corrosion and shall comply with all the requirements in this part of ISO 9173 after 100 reprocessing cycles, as recommended by the manufacturer.

Test in accordance with [5.2](#).

NOTE Discolouration due to water marking does not constitute evidence of corrosion.

4.6 Joint opening/closing force

The joint of the extraction forceps shall be so constructed that the extraction forceps opens and closes smoothly.

The torque required to operate shall be between 0,20 N m and 0,68 N m.

Test in accordance with [5.3](#).

4.7 Joint movement

There shall be no perceptible sideways movement in any position of the joint between fully closed and a maximum handle opening of 50 mm when tested according to [5.4](#).

5 Test methods

5.1 Visual inspection

Visual inspection shall be carried out under normal vision, without magnification.

5.2 Resistance to reprocessing

Carry out 100 reprocessing cycles as recommended in the manufacturer's instructions, in accordance with ISO 17664. Visually inspect for any signs of corrosion. Retest for requirements as in [4.3](#) and [4.7](#). For the purpose of this test, a reprocessing cycle includes the methods of cleaning, disinfection and sterilization.

5.3 Joint opening/closing force

Mount the extraction forceps in a suitable apparatus to obtain a handle opening of 50 mm. Apply a force just sufficient to close the extraction forceps fully and record the moment of this force.

Compare the values obtained with the limits given in [4.6](#).

5.4 Joint movement

Grip each handle end between the index finger and thumb of each hand, and apply a force perpendicular to the hinge axis.

6 Marking

Each extraction forceps shall be permanently marked with the following information:

- a) name of manufacturer and/or brand name;
- b) pattern number;
- c) lot number;
- d) ISO 9173 (optional).

Bibliography

- [1] ISO 7153-1, *Surgical instruments — Metallic materials — Part 1: Stainless steel*
- [2] ISO 9173-2, *Dentistry — Extraction forceps — Part 2: Designation*
- [3] ISO 9173-3, *Dentistry — Extraction forceps — Part 3: Design*

