**Terminal units for medical gas pipeline
systems —**

Part 1:

**Terminal units for use with compressed
medical gases and vacuum**

Prises murales pour systèmes de distribution de gaz médicaux —

Partie 1: Prises murales pour les gaz médicaux comprimés et le vide



PDF disclaimer

This PDF file may contain embedded typefaces. In accordance with Adobe's licensing policy, this file may be printed or viewed but shall not be edited unless the typefaces which are embedded are licensed to and installed on the computer performing the editing. In downloading this file, parties accept therein the responsibility of not infringing Adobe's licensing policy. The ISO Central Secretariat accepts no liability in this area.

Adobe is a trademark of Adobe Systems Incorporated.

Details of the software products used to create this PDF file can be found in the General Info relative to the file; the PDF-creation parameters were optimized for printing. Every care has been taken to ensure that the file is suitable for use by ISO member bodies. In the unlikely event that a problem relating to it is found, please inform the Central Secretariat at the address given below.



COPYRIGHT PROTECTED DOCUMENT

© ISO 2008

All rights reserved. Unless otherwise specified, no part of this publication may be reproduced or utilized in any form or by any means, electronic or mechanical, including photocopying and microfilm, without permission in writing from either ISO at the address below or ISO's member body in the country of the requester.

ISO copyright office
Case postale 56 • CH-1211 Geneva 20
Tel. + 41 22 749 01 11
Fax + 41 22 749 09 47
E-mail copyright@iso.org
Web www.iso.org

Published in Switzerland

Contents

Page

Foreword	iv
Introduction.....	v
1 Scope	1
2 * Normative references	2
3 Terms and definitions	2
4 General requirements	6
4.1 Safety	6
4.2 * Alternative construction.....	6
4.3 Materials	6
4.4 Design requirements.....	7
4.5 Constructional requirements	10
5 Test methods	11
5.1 General	11
5.2 Test for endurance	11
5.3 Test for pressure drop	12
5.4 Test for connection force and torque.....	13
5.5 Test for disconnection force and torque	14
5.6 Test for mechanical strength	14
5.7 Test for leakage	14
5.8 Test for gas specificity.....	15
5.9 Test for effective connection of probes	15
5.10 Test for durability of markings and colour coding	15
6 Marking, colour coding and packaging.....	15
6.1 Marking.....	15
6.2 Colour coding	16
6.3 Packaging.....	16
7 Information to be supplied by the manufacturer	16
Annex A (informative) Rationale.....	17
Annex B (informative) Environmental aspects	18
Annex C (informative) Special national and regional conditions for electrical installations	19
Bibliography.....	20

Foreword

ISO (the International Organization for Standardization) is a worldwide federation of national standards bodies (ISO member bodies). The work of preparing International Standards is normally carried out through ISO technical committees. Each member body interested in a subject for which a technical committee has been established has the right to be represented on that committee. International organizations, governmental and non-governmental, in liaison with ISO, also take part in the work. ISO collaborates closely with the International Electrotechnical Commission (IEC) on all matters of electrotechnical standardization.

International Standards are drafted in accordance with the rules given in the ISO/IEC Directives, Part 2.

The main task of technical committees is to prepare International Standards. Draft International Standards adopted by the technical committees are circulated to the member bodies for voting. Publication as an International Standard requires approval by at least 75 % of the member bodies casting a vote.

Attention is drawn to the possibility that some of the elements of this document may be the subject of patent rights. ISO shall not be held responsible for identifying any or all such patent rights.

ISO 9170-1 was prepared by Technical Committee ISO/TC 121, *Anaesthetic and respiratory equipment*, Subcommittee SC 6, *Medical gas systems*.

This second edition cancels and replaces the first edition (ISO 9170-1:1999) which has been technically revised.

ISO 9170 consists of the following parts, under the general title *Terminal units for medical gas pipeline systems*:

- *Part 1: Terminal units for use with compressed medical gases and vacuum*
- *Part 2: Terminal units for anaesthetic gas scavenging systems*

Introduction

Terminal units are the points on a medical gas pipeline system where the operator makes connections and disconnections for the supply of specified medical gases to anaesthetic machines, lung ventilators or other items of medical equipment. A wrong connection can create a hazard to the patient or operator. It is important that terminal units and their components be designed, manufactured, installed and maintained in such a way as to meet the basic requirements specified in this part of ISO 9170.

This part of ISO 9170 pays particular attention to:

- suitability of materials;
- gas specificity;
- cleanliness;
- testing;
- identification;
- information supplied.

This part of ISO 9170 specifies the provision of information for the installation and subsequent testing of terminal units prior to use. Testing of terminal units prior to use is critical to patient safety, and it is essential that terminal units are not used until full testing in accordance with ISO 7396-1 has been completed.

Annex A contains rationale statements for some of the requirements of this part of ISO 9170. The clauses and subclauses marked with an asterisk (*) after their number have corresponding rationale contained in Annex A, included to provide additional insight into the reasoning that led to the requirements and recommendations that have been incorporated in this document. It is considered that knowledge of the reasons for the requirements will not only facilitate the proper application of this part of ISO 9170, but will expedite any subsequent revisions.

Terminal units for medical gas pipeline systems —

Part 1:

Terminal units for use with compressed medical gases and vacuum

1 Scope

1.1 This part of ISO 9170 applies to:

- a) terminal units intended for use in medical gas pipeline systems in accordance with ISO 7396-1, for use with the following medical gases:
- oxygen;
 - nitrous oxide;
 - medical air;
 - carbon dioxide;
 - oxygen/nitrous oxide mixture [50 %/50 % (by volume)];
- b) terminal units intended for use in medical gas pipeline systems in accordance with ISO 7396-1, for use with the following gases and services:
- oxygen-enriched air;
 - air for driving surgical tools;
 - nitrogen for driving surgical tools;
 - vacuum.

NOTE 1 Different names or symbols are used for air for driving surgical tools, such as instrument air, surgical air, air motor, air-700 and air-800.

NOTE 2 The requirements of this part of ISO 9170 can be used as guidelines for terminal units for other gases. These other gases will be considered for inclusion in this part of ISO 9170 when they come into general use.

It is intended especially to ensure the gas-specific assembly of terminal units and to prevent their interchange between different gases and services.

1.2 This part of ISO 9170 specifies requirements for terminal units for supply and disposal of nitrogen or air for driving surgical tools.

1.3 This part of ISO 9170 specifies requirements for probes intended to be connected to the gas-specific connection point which is part of the terminal unit.

1.4 This part of ISO 9170 does not specify the dimensions of probes or of the gas-specific connection points of the terminal units.

NOTE Certain regional or national standards specifying dimensions of probes and gas-specific connection points are given in the Bibliography.

1.5 This part of ISO 9170 does not specify the dimensions of NIST connectors, which are defined in ISO 5359.

1.6 This part of ISO 9170 does not specify the dimensions of DISS connectors, which are defined in CGA V-5¹⁾ [12].

1.7 This part of ISO 9170 does not specify the requirements for terminal units for anaesthetic gas scavenging systems (AGSS), which are covered in ISO 9170-2.

2 * Normative references

The following referenced documents are indispensable for the application of this document. For dated references, only the edition cited applies. For undated references, the latest edition of the referenced document (including any amendments) applies.

ISO 32:1977, *Gas cylinders for medical use — Marking for identification of content*

ISO 5359:—²⁾, *Low-pressure hose assemblies for use with medical gases*

ISO 6506-1:2005, *Metallic materials — Brinell hardness test — Part 1: Test method*

ISO 7396-1:2007, *Medical gas pipeline systems — Part 1: Pipeline systems for compressed medical gases and vacuum*

ISO 11114-3:1997, *Transportable gas cylinders — Compatibility of cylinder and valve materials with gas contents — Part 3: Autogenous ignition test in oxygen atmosphere*

ISO 14971:2007, *Medical devices — Application of risk management to medical devices*

ISO 15001:2003, *Anaesthetic and respiratory equipment — Compatibility with oxygen*

3 Terms and definitions

For the purposes of this document, the following terms and definitions apply.

NOTE A diagram of a typical terminal unit and probe, with an example of terminology, is shown in Figure 1.

3.1 diameter-index safety system connector DISS connector

any of a range of male and female components intended to maintain gas-specificity by allocation of a set of different diameters to the mating connectors for each particular gas

3.2 gas-specific

having characteristics which prevent connections between different gas services

1) CGA = Compressed Gas Association.

2) To be published. (Revision of ISO 5359:2000)

3.3**gas-specific connection point**

that part of the socket which is the receptor for a gas-specific probe

3.4**gas-specific connector**

connector with dimensional characteristics that prevent connections between different gas services

NOTE Examples of gas-specific connectors are quick connectors, screw-threaded connectors, diameter-index safety system (DISS) connectors or non-interchangeable screw-threaded (NIST) connectors.

3.5**low-pressure hose assembly**

assembly that consists of a flexible hose with permanently attached gas-specific inlet and outlet connectors, and which is designed to conduct a medical gas at pressures less than 1 400 kPa

3.6**medical gas**

any gas or mixture of gases intended to be administered to patients for therapeutic, diagnostic or prophylactic purposes, or for surgical tool application(s)

3.7**medical gas pipeline system**

complete system which comprises a supply system, a monitoring and alarm system and a pipeline distribution system with terminal units at the points where medical gases or vacuum may be required

3.8**medical gas supply system**

either

- a) a medical gas pipeline system or
- b) an installation having no permanent pipeline system but employing a medical gas supply source complete with pressure regulator(s)

3.9**nominal distribution pressure**

pressure which the medical gas pipeline system is intended to deliver at the terminal units

NOTE Unless otherwise specified, pressures in this part of ISO 9170 are expressed as gauge pressures (i.e. atmospheric pressure is defined as 0).

3.10**non-interchangeable screw-threaded connector****NIST connector**

range of male and female components intended to maintain gas specificity by the allocation of a set of different diameters and a left- or right-hand screw thread to the mating components for each particular gas

3.11**probe**

gas-specific male component designed for acceptance by and retention in the socket

3.12**quick connector**

pair of non-threaded gas-specific components which can be easily and rapidly joined together by a single action of one or both hands without the use of tools

3.13

single-fault condition

condition in which a single means for protection against a safety hazard in equipment is defective or a single external abnormal condition is present

3.14

socket

female part of a terminal unit which is either integral or attached to the terminal unit base block by a gas-specific interface and which contains the gas-specific connection point

3.15

terminal unit

outlet assembly (inlet for vacuum) in a medical gas supply system at which the operator makes connections and disconnections

3.16

terminal unit base block

that part of a terminal unit which is attached to the pipeline distribution system

3.17

terminal unit check valve

valve which remains closed until opened by insertion of an appropriate probe and which then permits flow in either direction

3.18

terminal unit maintenance valve

valve that permits maintenance of the terminal unit without shutting down the pipeline system to other terminal units

3.19

terminal unit for supply and disposal of nitrogen or air for driving surgical tools

combination of an outlet assembly (for supply) and an inlet assembly (for disposal) which are connected to a medical gas pipeline system and to a gas disposal system respectively and at which the operator makes connections and disconnections by means of a combined probe

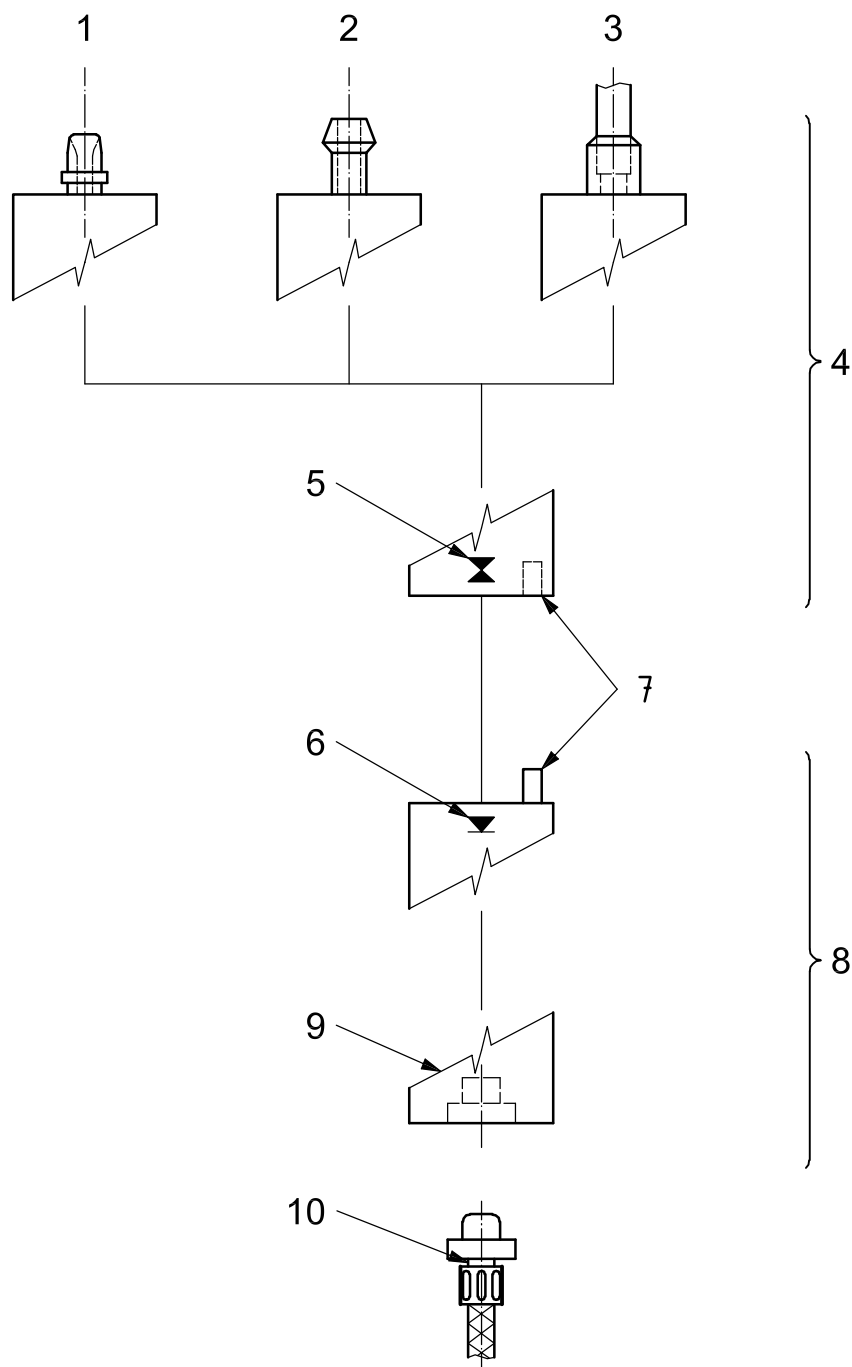

Key

- 1 NIST or DISS body
- 2 hose insert
- 3 point for brazed connection
- 4 base block
- 5 maintenance valve
- 6 check valve
- 7 gas-specific interface
- 8 socket
- 9 gas-specific connection point
- 10 probe

Figure 1 — Typical components of a terminal unit and probe

4 General requirements

4.1 Safety

Terminal units shall, when transported, stored, installed, operated in normal use and maintained according to the instructions of the manufacturer, present no risks that are not reduced to an acceptable level using risk management procedures in accordance with ISO 14971 and which are connected with their intended application, in normal condition and in single fault condition.

NOTE Maintenance of equipment is considered a normal condition.

4.2 * Alternative construction

Terminal units and components, or parts thereof, which use materials or have forms of construction different from those detailed in this clause, shall be presumed to be in compliance with the safety objectives of this part of ISO 9170 if it can be demonstrated that an equivalent degree of safety is obtained (i.e. compliance with requirements presumes that risks have been mitigated to acceptable levels) unless objective evidence to the contrary becomes available.

Evidence of an equivalent degree of safety shall be provided by the manufacturer upon request.

NOTE 1 Objective evidence can be obtained by postmarket surveillance.

NOTE 2 Regional or national regulations might require the provision of evidence to a competent authority or conformity assessment body (e.g. notified body in the European Economic Area) upon request.

4.3 Materials

4.3.1 Materials in contact with the gases listed in 1.1, during normal use shall be resistant to corrosion and compatible with oxygen, the other gases and their mixtures in the temperature range specified in 4.3.2.

NOTE 1 Corrosion resistance includes resistance against moisture and surrounding materials.

NOTE 2 Compatibility with oxygen involves both combustibility and ease of ignition. Materials that burn in air burn violently in pure oxygen. Many materials that do not burn in air will do so in pure oxygen, particularly under pressure. Similarly, materials that can be ignited in air require lower ignition energies in oxygen. Many such materials can be ignited by friction at a valve seat or by adiabatic compression produced when oxygen at high pressure is rapidly introduced into a system initially at low pressure.

NOTE 3 ISO 15001 contains information on selection of metallic and non-metallic materials and other aspects of compatibility of equipment with oxygen.

NOTE 4 Regional or national regulations may require the provision of evidence to a competent authority or conformity assessment body (e.g. notified body in the European Economic Area) upon request.

4.3.2 The materials shall permit the terminal units and their components to meet the requirements of 4.4 in the temperature range of -20 °C to $+60\text{ °C}$.

4.3.3 Terminal units shall meet the requirements of 4.4 after being exposed, while packed for transport and storage, to environmental conditions as specified by the manufacturer.

4.3.4 Springs, highly strained components and parts liable to wear which come in contact with the gas shall not be plated.

NOTE Plating could come off.

4.3.5 For terminal units for all gases, the autoignition temperature of the non-metallic components in contact with the gas, including the sealing materials and lubricants (if used), shall not be lower than 160 °C.

The determination of the autoignition temperature shall be carried out in accordance with ISO 11114-3.

NOTE The maximum permitted operating temperature of tested material is 100 °C lower than the autoignition temperature at the corresponding oxygen pressure. This safety margin is necessary because it covers both an unforeseen increase in the operating temperature and the fact that the autoignition temperature is not a constant. Values of the autoignition temperature always depend on the test method used, which may not exactly simulate all possible operating conditions.

4.3.6 Evidence of conformity with the requirements of 4.3.1 to 4.3.5 shall be provided by the manufacturer upon request.

NOTE Regional or national regulations may require the provision of evidence to a competent authority or conformity assessment body (e.g. notified body in the European Economic Area) upon request.

4.4 Design requirements

4.4.1 Medical gas supply pressure

4.4.1.1 Terminal units for oxygen, oxygen-enriched air, nitrous oxide, medical air, carbon dioxide and oxygen/nitrous oxide mixture (50 %/50 % by volume) shall operate and meet the requirements of this part of ISO 9170 for a medical gas supply having a pressure range from 320 kPa to 600 kPa.

4.4.1.2 Terminal units for oxygen, oxygen-enriched air, nitrous oxide, medical air, carbon dioxide and oxygen/nitrous oxide mixture (50 %/50 % by volume) shall not create a hazard at an inlet pressure of 1 200 kPa.

4.4.1.3 Terminal units for oxygen, oxygen-enriched air, nitrous oxide, medical air, carbon dioxide and oxygen/nitrous oxide mixture (50 %/50 % by volume) shall meet the requirements of 4.4.1.1 following exposure to an inlet pressure of 1 200 kPa for 5 min.

4.4.1.4 Terminal units for nitrogen or air for driving surgical tools shall operate and meet the requirements of this part of ISO 9170 for a medical gas supply having a pressure range from 560 kPa to 1 200 kPa.

4.4.1.5 Terminal units for nitrogen or air for driving surgical tools shall not create a hazard at an inlet pressure of 2 400 kPa.

4.4.1.6 Terminal units for nitrogen or air for driving surgical tools shall meet the requirements of 4.4.1.4 following exposure to an inlet pressure of 2 400 kPa for 5 min.

4.4.1.7 Terminal units for vacuum shall operate and meet the requirements of this part of ISO 9170 for a vacuum supply having a pressure range from 10 kPa to 60 kPa absolute.

4.4.1.8 * Terminal units for vacuum shall not create a hazard at a test pressure of 500 kPa applied to the base block.

4.4.1.9 * Terminal units for vacuum shall meet the requirements of 4.4.1.7 following exposure to a test pressure of 500 kPa applied for 5 min to the base block.

4.4.1.10 Evidence of conformity with the requirements of 4.4.1.1 to 4.4.1.9 shall be provided by the manufacturer upon request.

NOTE Regional or national regulations may require the provision of evidence to a competent authority or conformity assessment body (e.g. notified body in the European Economic Area) upon request.

4.4.2 Terminal units for different pressures

Terminal units for the same gas at different nominal distribution pressures (e.g. medical air and air for driving surgical tools) shall have gas-specific connection points for each pressure.

4.4.3 Retention of gas specificity

If any gas-specific component is removed from the terminal unit, the gas specificity of the terminal unit shall be retained, or the terminal unit shall be rendered inoperable. If the terminal unit can be dismantled, it shall not be possible to re-assemble the components in such a way that the fully-assembled terminal unit is no longer gas-specific.

4.4.4 Gas-specific connection point

Each terminal unit shall include a gas-specific connection point that shall accept the appropriate gas-specific probe only. This connection point shall be included in a socket.

4.4.5 Terminal unit check valve

Each terminal unit shall include a check valve that shall open the gas supply when the probe is connected and shall shut off automatically when the probe is disconnected. The check valve shall be a component or assembly separate from the maintenance valve specified in 4.4.6.

4.4.6 Terminal unit maintenance valve

Except for vacuum services, each terminal unit shall be equipped with a maintenance valve, that may be manual or automatic. The maintenance valve shall be a separate component or assembly from the check valve specified in 4.4.5.

4.4.7 Connection of terminal units to the pipeline (see also 7.2)

4.4.7.1 Except for connection to a disposal system for nitrogen or air for driving surgical tools, the base block of a terminal unit shall be designed and manufactured for either permanent (e.g. by brazing or welding) or gas-specific (e.g. by means of an NIST or DISS body) connection to a pipeline distribution system. The connection shall comply with ISO 7396-1.

4.4.7.2 Connection to a low-pressure hose shall be either by direct ferruling on to a hose insert or by means of an NIST or DISS body and shall comply with ISO 5359. (See Figure 1.)

4.4.8 Socket

The attachment of a socket to its base block for a particular service shall be gas-specific.

4.4.9 Compliance

Compliance with 4.4.2 to 4.4.8 shall be tested by visual inspection, functional testing and/or measurement.

4.4.10 Endurance (connection/release)

4.4.10.1 Socket

The socket shall retain gas specificity and meet the requirements given in 4.4.11 to 4.4.17 after testing in accordance with 5.2.1.

4.4.10.2 Probe

The probe shall retain gas specificity and meet the requirements given in 4.4.11 to 4.4.17 after testing in accordance with 5.2.2.

4.4.11 * Pressure drop

The pressure drop across the terminal unit and its probe, measured at the test pressures and with the test flows given in Table 1, shall not exceed the values given in Table 1.

For terminal units for supply and disposal of nitrogen or air for driving surgical tools, the pressure drop across the outlet assembly shall not exceed the value given in Table 1; the pressure drop across the inlet assembly shall not exceed 25 kPa with a back pressure not exceeding 15 kPa.

The test for pressure drop is given in 5.3.

Table 1 — Requirements for flow and pressure drop across terminal units with probe inserted

Terminal unit nominal distribution pressure kPa	Test pressure kPa	Test flow l/min	Maximum pressure drop across a terminal unit kPa
400 to 500	320	40	15
400 to 500	320	200	70
700 to 1 000	560	350	70
Vacuum	40 ^a	25	15

^a Absolute pressure.

NOTE The values in Table 1 are in accordance with the requirements in 7.2.1, 7.2.2, 7.2.3, 7.2.4 and Table 2 of ISO 7396-1:2007 and 4.4.14 of ISO 5359:—.

4.4.12 Connection force and torque

The force and the torque required to insert and lock the probe into the terminal unit shall be:

- a) an axial force not exceeding 100 N and/or
- b) a torque not exceeding 1 N·m.

The test for connection force and torque is given in 5.4.

4.4.13 Disconnection force and torque

4.4.13.1 The force and the torque required to release the locking mechanism shall be:

- a) a push or pull of not more than 110 N and not less than 20 N and/or
- b) a torque of not more than 1 N·m and not less than 0,1 N·m.

4.4.13.2 When all locking provisions have been released, according to the manufacturer's instructions, disconnection of the probe from the terminal unit shall require a force of not more than 100 N.

4.4.13.3 The test for disconnection force and torque is given in 5.5.

NOTE Danger to personnel can arise as a result of the rapid expulsion of probes from terminal units. The design should prevent this from occurring.

4.4.14 Mechanical strength

The terminal unit shall withstand the application of a steady axial tensile force of not less than 500 N.

The test for mechanical strength is given in 5.6.

4.4.15 Leakage

4.4.15.1 The leakage from a terminal unit with and without the probe inserted shall not exceed 0,296 ml/min (which is equivalent to 0,03 kPa·l/min).

The test for leakage is given in 5.7.1 and 5.7.2.

4.4.15.2 The leakage from a terminal unit with the probe inserted and with a side force applied shall not exceed 0,296 ml/min (which is equivalent to 0,03 kPa·l/min).

The test for leakage is given in 5.7.3.

4.4.16 Gas specificity

The terminal unit shall only accept the probe for the gas for which it is intended.

The test for gas specificity is given in 5.8.

4.4.17 Effective connection of probes

A tactile and/or audible indication of locking shall be perceived on retention of the gas-specific probe.

The test for effective connection of probes is given in 5.9.

4.4.18 Electrical requirements

If required by regional or national regulations, terminal units shall be fitted with means for connection to an equipotential bonding installation.

NOTE 1 Regional or national regulations which apply to electrical installations in medical locations might exist.

NOTE 2 Annex C lists some regional and national regulations for electrical installations.

4.5 Constructional requirements

4.5.1 Cleaning

Terminal units for all services shall be cleaned to meet the requirements of ISO 15001.

Evidence shall be provided by the manufacturer upon request.

NOTE Regional or national regulations might require the provision of evidence to a competent authority or conformity assessment body (e.g. notified body in the European Economic Area) upon request.

4.5.2 Lubricants

If lubricants are used, they shall be compatible with oxygen, the other medical gases and their mixtures in the temperature range specified in 4.3.2.

Evidence shall be provided by the manufacturer upon request.

NOTE Regional or national regulations might require the provision of evidence to a competent authority or conformity assessment body (e.g. notified body in the European Economic Area) upon request.

5 Test methods

5.1 General

These are type tests.

5.1.1 Ambient conditions

Except where otherwise stated, tests shall be carried out at ambient conditions.

5.1.2 Test gas

All positive pressure tests shall be carried out with clean, oil-free, dry air or nitrogen. Tests shall be carried out with dry gas with a maximum moisture content of 50 µg/g corresponding to a dew point of -48 °C at atmospheric pressure.

Tests for the pressure drop across terminal units for vacuum using the apparatus shown in Figure 3 shall use ambient air.

5.1.3 Reference conditions

Flowrates shall be corrected to 23 °C and 101,3 kPa.

5.2 Test for endurance

5.2.1 Socket

Fix the terminal unit to be tested to a horizontal or vertical surface, as appropriate, using the procedure recommended by the manufacturer. Apply a test pressure at the inlet to the base block of the terminal unit. Use a test pressure of 1 200 kPa for terminal units for nitrogen or air for driving surgical tools, a test pressure of 600 kPa for all other terminal units for compressed gases or a test pressure of 60 kPa absolute for vacuum.

Using a test probe made of corrosion-resistant steel of minimum chromium content of 17 % and a surface Brinell hardness of 210 HBW 1/30 (in accordance with ISO 6506-1), connect and release the probe 10 000 times at a frequency of not more than 10 operations per minute, with the seals being changed every 1 000 operations or according to the manufacturer's instructions, whichever is the greater interval.

Test the socket for compliance with 4.4.11 to 4.4.17.

5.2.2 Probe

Fix a terminal unit complying with this part of ISO 9170 to a horizontal or vertical surface, as appropriate, using the procedure recommended by the manufacturer. Apply a test pressure at the inlet to the base block of the terminal unit. Use a test pressure of 1 200 kPa for terminal units for nitrogen or air for driving surgical tools, a test pressure of 600 kPa for all other terminal units for compressed gases or a test pressure of 60 kPa absolute for vacuum.

Connect and release the probe 10 000 times at a frequency of not more than 10 operations per minute, with the seals being changed every 1 000 operations or according to the manufacturer's instructions, whichever is the greater interval.

Test the probe for compliance with 4.4.11 to 4.4.17.

5.3 Test for pressure drop

Using an apparatus of typical configuration as shown in Figure 2 for terminal units for compressed medical gases, Figure 3 for terminal units for vacuum or Figure 4 for terminal units for supply and disposal of nitrogen or air for driving surgical tools, set the test pressure and flow at the inlet of the terminal unit to the appropriate values given in Table 1 and in 4.4.11.

Measure the pressure drop across the terminal unit with the probe inserted.

For terminal units for the supply and disposal of nitrogen or air for driving surgical tools, measure the pressure drops across the outlet and inlet assemblies simultaneously.

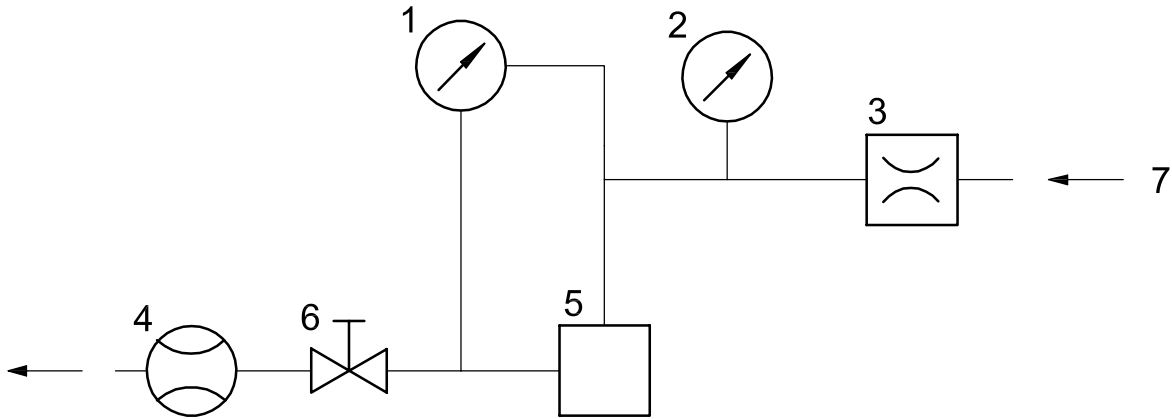

Key

- | | |
|--|-------------------------------------|
| 1 pressure-differential measuring device | 5 terminal unit with probe inserted |
| 2 pressure gauge | 6 flow control valve |
| 3 pressure regulator | 7 pressure supply |
| 4 flowmeter | |

Figure 2 — Typical apparatus for measuring pressure drop across a terminal unit for compressed medical gases

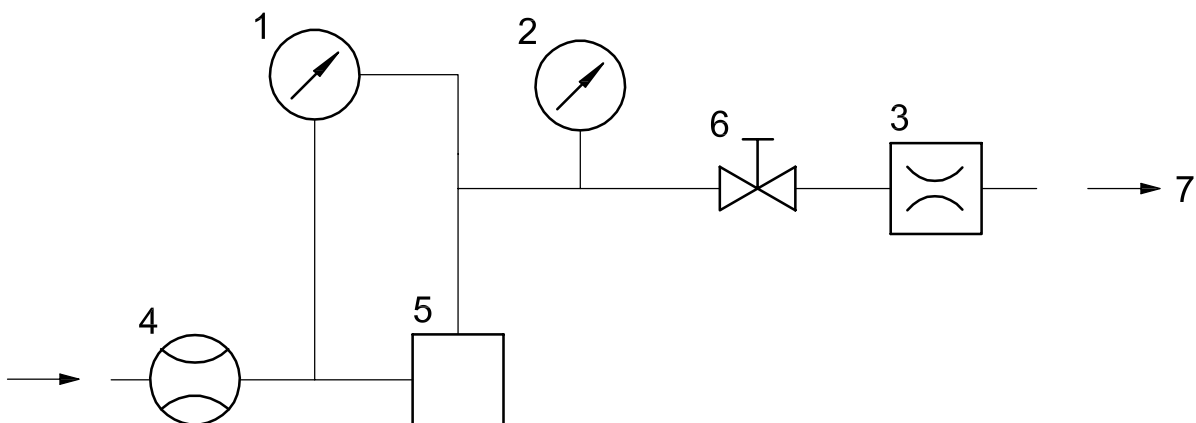

Key

- | | |
|--|-------------------------------------|
| 1 pressure-differential measuring device | 5 terminal unit with probe inserted |
| 2 pressure gauge | 6 flow control valve |
| 3 vacuum regulator | 7 vacuum supply |
| 4 flowmeter | |

Figure 3 — Typical apparatus for measuring pressure drop across a terminal unit for vacuum

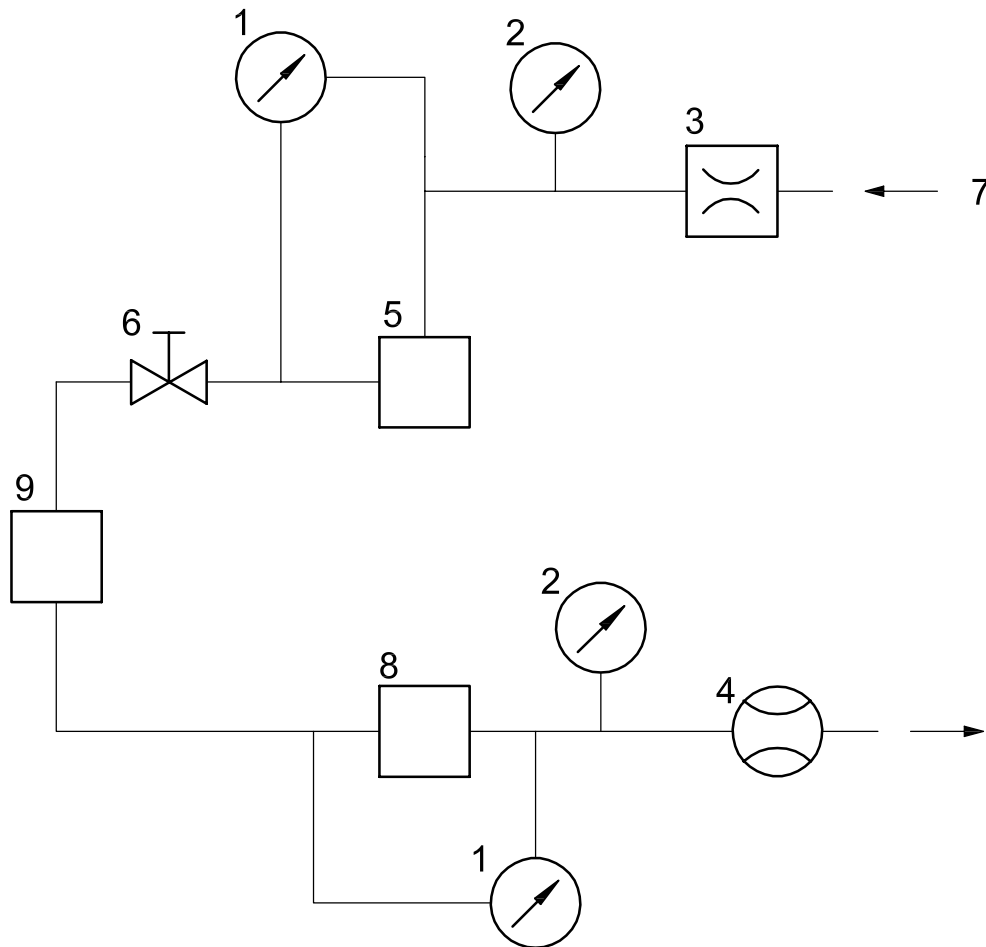

Key

- 1 pressure-differential measuring device
- 2 pressure gauge
- 3 pressure regulator
- 4 flowmeter
- 5 inlet assembly of terminal unit with probe inserted
- 6 flow control valve
- 7 pressure supply
- 8 outlet assembly of terminal unit with probe inserted
- 9 connection between supply and disposal sides of probe

Figure 4 — Typical apparatus for measuring pressure drop across a terminal unit for supply and disposal of nitrogen or air for driving surgical tools

5.4 Test for connection force and torque

Adapt a probe to accommodate a suitable measuring device. Fix the terminal unit to a horizontal or vertical surface, as appropriate, using the procedure recommended by the manufacturer.

Apply a test pressure at the inlet to the base block of the terminal unit. Use a test pressure of 1 200 kPa for terminal units for nitrogen or air for driving surgical tools, a test pressure of 600 kPa for all other terminal units for compressed gases or a test pressure of 60 kPa absolute for vacuum.

In accordance with the manufacturer's instructions, insert the adapted probe into the terminal unit and record the force and/or torque required to insert and lock the probe.

5.5 Test for disconnection force and torque

Adapt a probe to accommodate a suitable measuring device.

Fix the terminal unit to a horizontal or vertical surface, as appropriate, using the procedure recommended by the manufacturer.

Apply a test pressure at the inlet to the base block of the terminal unit. Use a test pressure of 640 kPa for terminal units for nitrogen or air for driving surgical tools, a test pressure of 320 kPa for all other terminal units for compressed gases or a test pressure of 40 kPa absolute for vacuum.

Insert the adapted probe into the terminal unit in accordance with the manufacturer's instructions and ensure that it is fully engaged.

Release the locking mechanism and disconnect the probe in accordance with the manufacturer's instructions and record the force and/or torque required to release each locking mechanism. If the recommended disconnection method involves applying, for example, a compressive force to reduce the effort required to disengage the locking mechanism, measure each separate force/torque involved.

5.6 Test for mechanical strength

Adapt a blanked probe in order to apply tensile force.

Fix the terminal unit to a suitable surface using the procedure recommended by the manufacturer.

Apply a test pressure at the inlet to the base block of the terminal unit. Use a test pressure of 1 200 kPa for terminal units for nitrogen or air for driving surgical tools, a test pressure of 600 kPa for all other terminal units for compressed gases or a test pressure of 60 kPa absolute for vacuum.

Insert the adapted probe.

Apply a tensile force of 500 N and hold it for 1 min.

Remove the tensile force, check that the terminal unit is completely functional and the leakage is in accordance with 4.4.15.

Dismantle the terminal unit and check that no damage or distortion has occurred to either the terminal unit components or the probe.

5.7 Test for leakage

5.7.1 Fix the terminal unit to a horizontal or vertical surface, as appropriate, using the procedure recommended by the manufacturer.

Apply a test pressure at the inlet of the base block of the terminal unit. Use the following test pressures:

- a) 320 kPa and 600 kPa for terminal units for compressed medical gases;
- b) 560 kPa and 1 200 kPa for terminal units for nitrogen or air for driving surgical tools;
- c) 10 kPa and 60 kPa absolute for vacuum.

Measure the leakage under the conditions of maximum test pressure and minimum test pressure.

5.7.2 Keep the terminal unit pressurized as described in 5.7.1 and insert a gas-specific blanked probe. Measure the leakage under the conditions of maximum and minimum test pressures.

5.7.3 Apply a force of 20 N perpendicular to the long axis of the probe, 50 mm from the outermost surface of the terminal unit. Measure the leakage whilst the force is applied to the probe under the conditions of maximum and minimum test pressures.

5.8 Test for gas specificity

Carry out the test by attempting to connect gas-specific test probes for all other medical gases, in turn, to the gas-specific connection point of each socket.

5.9 Test for effective connection of probes

Carry out the test by inserting the gas-specific probe and checking that a tactile and/or audible indication of locking is perceived.

5.10 Test for durability of markings and colour coding

Rub the markings and colour coding by hand, without undue pressure, first for 15 s with a cloth rag soaked with distilled water, then for 15 s with a cloth rag soaked with ethanol and then for 15 s with a cloth rag soaked with isopropanol. Carry out this test at ambient temperature. Verify that the markings required in 6.1 and 6.2 are still legible.

6 Marking, colour coding and packaging

6.1 Marking

6.1.1 Terminal units, probes and their gas-specific components shall be durably and legibly marked with the symbol of the relevant gas in accordance with Table 2.

The test for the durability of markings is given in 5.10.

NOTE In addition to the symbol, the name of the gas can be used.

6.1.2 The height of the lettering shall be at least 2,5 mm.

6.1.3 Terminal units and probes shall be marked with the manufacturer's name or identification mark and, if applicable, with additional means to ensure traceability such as type, batch or serial number or year of manufacture.

Table 2 — Symbols and colour coding for medical gases

Medical gas or mixture	Symbol	Colour coding ^{a, b}
Oxygen	O ₂	White
Oxygen-enriched air		
Nitrous oxide	N ₂ O	Blue
Medical air	Air ^c	Black-White
Air for driving surgical tools	Air – 800 ^c	Black-White
Air for driving surgical tools (with disposal)	Air motor ^c	Black-White
Nitrogen for driving surgical tools	N ₂ – 800	Black
Carbon dioxide	CO ₂	Grey
Oxygen/nitrous oxide mixture 50 %/50 % (by volume)	O ₂ /N ₂ O	White-blue
Vacuum	Vac ^c	Yellow

^a According to ISO 32, except vacuum.

^b An example of yellow is given by NCS 0060Y in SS 01 92 02.

^c National languages may be used for air and vacuum.

6.2 Colour coding

6.2.1 If colour coding is used, it shall be in accordance with Table 2 or the appropriate regional or national standard.

6.2.2 Colour coding shall be durable.

The test for the durability of colour coding is given in 5.10.

6.3 Packaging

6.3.1 Terminal units, gas-specific probes and spare parts shall be sealed to protect against particulate contamination and packaged to prevent damage during storage and transportation.

6.3.2 Packages shall provide a means of identification of the contents.

7 Information to be supplied by the manufacturer

7.1 Terminal units shall be accompanied by a technical description; instructions for use, storage and transportation; and an address to which the operator can refer.

7.2 The manufacturer shall provide instructions for installation and a reference to the testing procedures for terminal units given in ISO 7396-1.

7.3 Instructions for use shall include information necessary for the operation of the terminal unit in accordance with its specification and shall include a description of the procedure for connection and disconnection of probes. Instructions for use shall give detailed instructions for cleaning, inspection and preventive maintenance to be performed by the operator or by authorized persons, and shall recommend the frequency of such activities. A list of recommended spare parts shall be provided.

7.4 Particular attention shall be given to the following safety-related items:

- the danger of fire or explosion due to the use of lubricants not recommended by the manufacturer;
- the range of operating pressures;
- the hazard due to the use of improper probes.

Annex A (informative)

Rationale

This annex provides a rationale for some requirements of this part of ISO 9170 and is intended for those who are familiar with the subject of this document but who have not participated in its development. An understanding of the rationale underlying these requirements is considered to be essential for their proper application. Furthermore, as clinical practice and technology change, it is believed that a rationale will facilitate any revision of this part of ISO 9170 necessitated by those developments.

The following correspond to clauses and subclauses marked with an asterisk (*) in this part of ISO 9170. The numbering is, therefore, not consecutive.

A.2 Only dated references are used in this part of ISO 9170. As stated in the preamble of the European Medical Device Directive 93/42/EEC, manufacturers shall take account of technology and practice existing at the time of design, and of technical and economical considerations compatible with a high level of protection of health and safety. This is to ensure that a manufacturer does not design against a moving target (i.e. a standard that is revised after completion of the specification), before the device is placed on the market. Having only dated references will ensure that design specifications are developed using clearly defined standards that reflect the generally acknowledged state of the art at the time of design, except for emerging hazards requiring amendment of existing standards.

SG1 of the Global Harmonization Task Force (GHTF) (www.ghtf.org) is developing a guideline, SG1/N044^[13], which addresses the need to use dated references.

A.4.2 Attention is drawn to ISO 14971 on risk management and to the International Standards under development by ISO/TC 210 on risk evaluation and risk control.

A.4.3.1 Terminal units for different gases are often made with interchangeable components or subassemblies. The requirement for compatibility with oxygen should therefore be applied to terminal units for all gases.

A.4.4.1.8, A.4.4.1.9 The testing of vacuum pipeline systems given in ISO 7396-1 requires exposure of vacuum terminal units to a positive pressure of 500 kPa for 5 min as a test of mechanical integrity.

A.4.4.11 Lung ventilators can require peak flows of 200 l/min for up to 3 s. Experience shows that such ventilators can be supplied by terminal units that meet the requirements of 4.4.11.

Annex B (informative)

Environmental aspects

Planning and design of products applying to this part of ISO 9170 should consider the environmental impact from the product during its life cycle. The environmental impact generated by terminal units for use with compressed medical gases and vacuum is mainly restricted to the following occurrences:

- impact at local environment caused by leakage;
- impact at local environment caused by cross-connection;
- the danger of fire or explosion due to the use of unsuitable materials or lubricants;
- cleaning.

To highlight the importance of reducing the environmental burden, this part of ISO 9170 addresses requirements or recommendations intended to decrease environmental impact caused by those aspects.

See Table B.1 for a mapping of the life cycle of a terminal unit for use with compressed medical gases and vacuum to aspects of the environment.

Table B.1 — Environmental aspects addressed by clauses of this part of ISO 9170

	Environmental aspects (inputs and outputs)	Product life cycle			
		Production and preproduction Stage A	Distribution (including packaging) Stage B Addressed in Clause	Use Stage C Addressed in subclause	End of life Stage D
1	Resource Use	—	—	—	—
2	Energy consumption	—	—	—	—
3	Emissions to air	—	—	4.4.5 4.4.7 4.4.15 4.4.17	—
4	Emissions to water	—	—	—	—
5	Waste	—	—	—	—
6	Noise	—	—	—	—
7	Migration of hazardous substances	—	—	4.3	—
8	Impacts on soil	—	—	—	—
9	Risks to the environment from accidents or misuse	—	6 7	4.1 4.2 4.3 4.4.1 4.4.5 4.4.6 4.4.15 4.5	—

Annex C (informative)

Special national and regional conditions for electrical installations

The following table provides some of the known country- and market-specific electrical installation requirements. For the countries in which the relevant regional or national condition applies, the provisions shown below are normative, for other countries they are informative.

Country or region	Relevant regulations
Europe	IEC 60364-7-710, Ed. 1 ^[14]
Australia	AS/NZS 3000 ^[15] , AS/NZS 3003 ^[16]
USA	National Electric Code
Canada	Canadian Electrical Code
Japan	Japanese Industrial Standard

Bibliography

- [1] ISO 4135:2001, *Anaesthetic and respiratory equipment — Vocabulary*
- [2] ISO 9170-2:2008, *Terminal units for medical gas pipeline systems — Part 2: Terminal units for anaesthetic gas scavenging systems*
- [3] DIN 13260-2:2004, *Supply systems for medical gases — Part 2: Dimensions and allocation of probes and gas-specific connection points for terminal units for compressed medical gases and vacuum*
- [4] ENV 737-6:2003, *Medical gas pipeline systems — Part 6: Dimensions and allocation of probes for terminal units for compressed medical gases and vacuum*
- [5] AS 2896-1998, *Medical gas systems — Installation and testing of non-flammable medical gas pipeline systems*
- [6] AS 2902-2005, *Medical gas systems — Low pressure flexible hose assemblies*
- [7] NFPA 99:2005, *Health Care Facilities*
- [8] UNI 9507:2004 *Impianti di distribuzione di gas per uso medico — Unità terminali ed innesti (Medical gas pipeline systems — Terminal units and connectors)*
- [9] CAN/CSA-Z9170-1:2005, *Terminal units for medical gas pipeline systems — Part 1: Terminal units for use with compressed medical gases and vacuum*
- [10] SS 875 24 30:2004, *Medical gas pipeline systems — Connectors for medical gases*
- [11] NF S 90-116, *Matériel médico-chirurgical — Prises murales et fiches correspondantes pour fluides médicaux (Medico-surgical equipment — Terminal units and related probes for medical fluids)*
- [12] CGA V-5:2005, *Diameter index safety system (Non-interchangeable low pressure connections for medical gas applications)*
- [13] SG1/N044, *Role of Standards in the Assessment of Medical Devices*
- [14] IEC 60364-7-710:2002, *Electrical installations of buildings — Part 7-710: Requirements for special installations or locations — Medical locations*
- [15] AS/NZS 3000:2000, *Electrical installations (known as the Australian/New Zealand Wiring Rules)*
- [16] AS/NZS 3003:2003, *Electrical installations — Patient treatment areas of hospitals and medical, dental practices and dialyzing locations*

