

INTERNATIONAL STANDARD

**ISO
9141**

First edition
1989-10-01

Road vehicles — Diagnostic systems — Requirements for interchange of digital information

*Véhicules routiers — Systèmes de diagnostic — Caractéristiques de l'échange de
données numériques*



Reference number
ISO 9141 : 1989 (E)

Contents

	Page
Foreword	iii
Introduction	iv
1 Scope	1
2 Normative references	1
3 Definitions	1
4 General configurations	2
5 Signal and communication specifications	2
6 Initialization of the ECU prior to serial communication	5
7 Header	6
8 Requirements of the diagnostic tester	8
9 Requirements of the ECU	10
10 Requirements of the wiring	12

© ISO 1989

All rights reserved. No part of this publication may be reproduced or utilized in any form or by any means, electronic or mechanical, including photocopying and microfilm, without permission in writing from the publisher.

International Organization for Standardization
Case postale 56 • CH-1211 Genève 20 • Switzerland

Printed in Switzerland

Foreword

ISO (the International Organization for Standardization) is a worldwide federation of national standards bodies (ISO member bodies). The work of preparing International Standards is normally carried out through ISO technical committees. Each member body interested in a subject for which a technical committee has been established has the right to be represented on that committee. International organizations, governmental and non-governmental, in liaison with ISO, also take part in the work. ISO collaborates closely with the International Electrotechnical Commission (IEC) on all matters of electrotechnical standardization.

Draft International Standards adopted by the technical committees are circulated to the member bodies for approval before their acceptance as International Standards by the ISO Council. They are approved in accordance with ISO procedures requiring at least 75 % approval by the member bodies voting.

International Standard ISO 9141 was prepared by Technical Committee ISO/TC 22, *Road vehicles*.

Introduction

This International Standard has been established with a view to specifying the following desirable features for the diagnosis of electronically controlled on-board systems:

- 1) determination of the electrical requirements of a diagnostic system so that diagnostic equipment having at least minimum functional capability as specified herein will be compatible with any on-board diagnostic system designed in accordance with these specifications;
- 2) limitation of the number of contacts on electronically controlled systems for unidirectional and bidirectional diagnostic communication;
- 3) transmission of identifying information, as well as operational status information including actual values of parameter and required values.

The diagnostic communication is expected to fulfil one or more of the following aims:

- a) to determine if a system is functioning correctly;
- b) to carry out an inspection;
- c) to locate deviations from specification and achieve economic repair;
- d) to confirm a system has been restored to correct operation;
- e) to reset or adjust system operating values in an Electronic Control Unit (ECU) in strict accordance with the vehicle manufacturer's instructions;
- f) to give recorded information related to service activities.

This may be accomplished by way of one or more of the following:

- a) identification of the components in a system;
- b) output of diagnostic information from an ECU;
- c) examination of a wide range of sensor and operating parameter values;
- d) carrying out specific actions;
- e) changes in data held in the ECU in strict accordance with the vehicle manufacturer's instructions.

Road vehicles — Diagnostic systems — Requirements for interchange of digital information

1 Scope

This International Standard specifies the requirements for setting up the interchange of digital information between on-board Electronic Control Units (ECUs) of road vehicles and suitable diagnostic testers. This communication is established in order to facilitate inspection, test diagnosis and adjustment of vehicles, systems and ECUs.

This International Standard does not apply when system-specific diagnostic test equipment is used.

This International Standard does not apply to the use of flashing code techniques.

2 Normative references

The following standards contain provisions which, through reference in this text, constitute provisions of this International Standard. At the time of publication, the editions indicated were valid. All standards are subject to revision, and parties to agreements based on this International Standard are encouraged to investigate the possibility of applying the most recent editions of the standards indicated below. Members of IEC and ISO maintain registers of currently valid International Standards.

ISO 4092 : 1988, *Road vehicles — Diagnostic systems for motor vehicles — Vocabulary*.

ISO/TR 7637-0 : 1984, *Road vehicles — Electrical interference by conduction and coupling — Part 0: General and definitions*.

3 Definitions

For the purposes of this International Standard, the following definitions apply.

3.1 inspection: See ISO 4092.

3.2 test: See ISO 4092.

3.3 diagnosis: See ISO 4092.

3.4 diagnostic tester: See ISO 4092.

This non-built-in equipment may be used in the vehicle.

3.5 system: Assemblage of components performing a specific function, for example an assemblage of an ECU with its associated sensors, actuators and interconnections.

3.6 ECU: Abbreviation of Electronic Control Unit.

3.7 bus: One or more conductors connecting two or more ECUs together with the purpose of communicating with the test equipment.

3.8 NRZ: Abbreviation of Non-Return-to Zero — a method of representing binary signals in which there is no change of signal levels between two successive bits of the same logic level.

3.9 baud rate: Number of binary elements of information transmitted per second on one line.

3.10 LSB: Abbreviation of Least Significant Bit.

3.11 MSB: Abbreviation of Most Significant Bit.

3.12 initialization: Process to activate an ECU for starting communication.

3.13 key words: Identifier of a set of specifications for the subsequent serial communication.

This set of specifications defines:

- the specific function of each communication line;
- the format of the digital information such as the protocol, number and meaning of each of the words exchanged; and
- if a redefinition is desired, the format of data such as baud rate, data coding, word length.

3.14 header: First group of serial data transmitted to the diagnostic tester after initialization (if required) before further data exchange commences.

The header consists of

- baud rate synchronization pattern;
- key words.

3.15 bit time: Duration of one unit of information.

4 General configurations

4.1 ECU shall have one (K) or two (K and L) communication connections for inspection, test and diagnosis. Vehicle battery voltage V_B and common return G to the diagnostic tester shall be provided either from the ECU or from the vehicle. If lines K or L from two or more ECUs are connected together, the resulting system is called a bus system.

Line K is defined as the line which provides information in a serial digital form from ECU to the diagnostic tester. Line K may also be used bidirectionally, in which case it may carry commands or data from the diagnostic tester to the ECU. Line K may also be used to initialize the serial communication.

Line L is defined as a unidirectional line from the diagnostic tester to the ECU. When it exists, it may be used to initialize the serial communication and/or to carry commands and/or data.

It can be seen from the above, in that the communication on line K may be unidirectional or bidirectional, and that line L may or may not exist, that only the four following configurations may be used:

- 1) bidirectional line K with unidirectional line L;
- 2) unidirectional line K with unidirectional line L;
- 3) bidirectional line K without line L;
- 4) unidirectional line K without line L.

Other initialization may be used, as an alternative to using the K- and L-lines, in any of these cases.

ECUs using any of the above configurations and which do not run free may have their like communication lines linked on a bus.

Figure 1 shows the various possible system configurations indicating the role of each of the communication lines K and L.

4.2 If any ECUs, either of one type or in combination, are linked on a bus, the system designer shall ensure that the configuration is capable of correct operation. For example, data from one ECU shall not initialize the serial communication of another ECU on the bus and an initialization signal shall not cause more than one ECU to respond simultaneously; it may, however, initialize a number of ECUs on the bus which then respond in an orderly sequential manner.

If lines K and L are used for purposes other than inspection, test and diagnosis, care shall be taken to avoid data collision and incorrect operation in all modes.

Figure 2 shows the possible bus connections of the various types of ECUs including different means of initialization.

5 Signal and communication specifications

5.1 Signal

5.1.1 For proper operation of the serial communication, both ECU and diagnostic tester shall correctly determine each logic state as follows:

— a logic "0" is equivalent to a voltage level on the line of less than 20 % V_B for transmitter, 30 % for receiver;

— a logic "1" is equivalent to a voltage level on the line of greater than 80 % V_B for transmitter, 70 % for receiver.

In addition, the slope times shall be less than 10 % of the bit time. The slope times are defined as the time taken for the voltage to change from 20 % to 80 %, and 80 % to 20 % V_B for transmitters.

In the case of NRZ-code the bit time is defined as half of the time between the 50 % levels of successive rising or falling edges of alternating "1" and "0" bits.

Figures 3 and 4 illustrate the worst case on signal levels.

For electrical specifications of diagnostic testers, see 8.5 and of ECUs, see 9.2.

5.1.2 For present economic reasons the baud rate shall be limited to 10 kbaud and will be revised as technical and economic factors allow. The minimum baud rate shall be 10 baud.

The transmission speed of the address (see 8.3), if used, shall be 5 baud.

5.2 Communication

5.2.1 The schematics used are shown in figure 5.

5.2.2 The capacitance contributions of the diagnostic tester and cables, C_{TE} , shall not exceed 2 nF.

The sum of the input capacitances of all ECUs (C_{ECU}) on the bus, the capacitance of the on-board serial communication line, C_{OBW} , the capacitance of the diagnostic tester and its cables, C_{TE} , and the baud rate, BR (NRZ-code), shall be chosen such that the following inequality holds:

$$BR < \frac{10^{-4}}{\sum_{i=1}^n C_{ECU_i} + C_{OBW} + C_{TE}}$$

The value, BR, shall be divided by 2 for 24 V systems.

If this calculation results in a baud rate greater than 10 kbaud, reference shall be made to 5.1.2.

As an example, a bus system can be chosen as follows:

$$\begin{aligned} n &= 5 \text{ (number of ECUs)} \\ \left. \begin{aligned} C_{ECU} &= 2 \text{ nF} \\ C_{OBW} &= 3 \text{ nF} \end{aligned} \right\} \text{ Then } BR < 6,6 \text{ kbaud} \end{aligned}$$

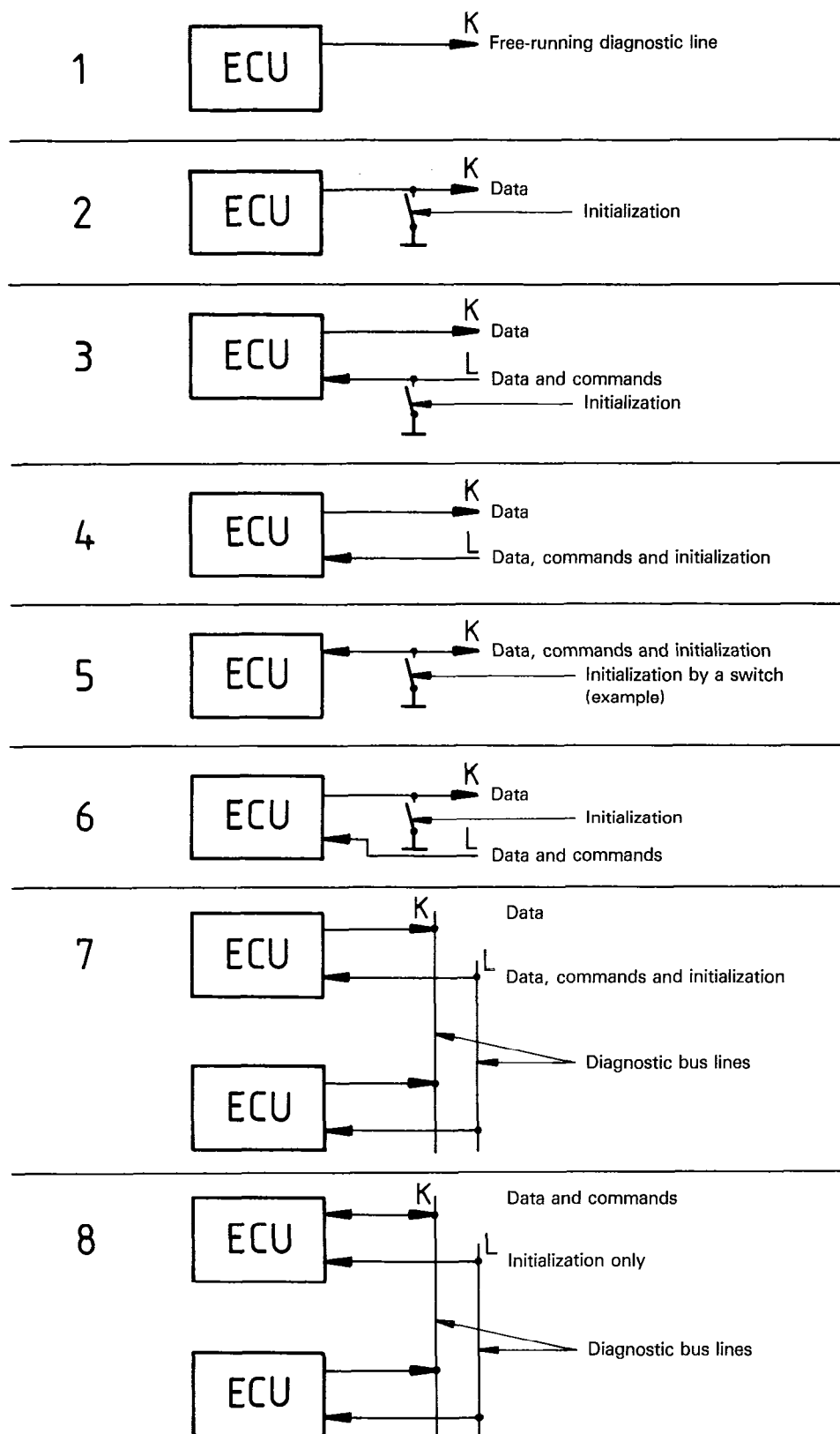

The arrow indicates direction of data flow
 The switch indicates initialization

Figure 1 — Possible system configurations

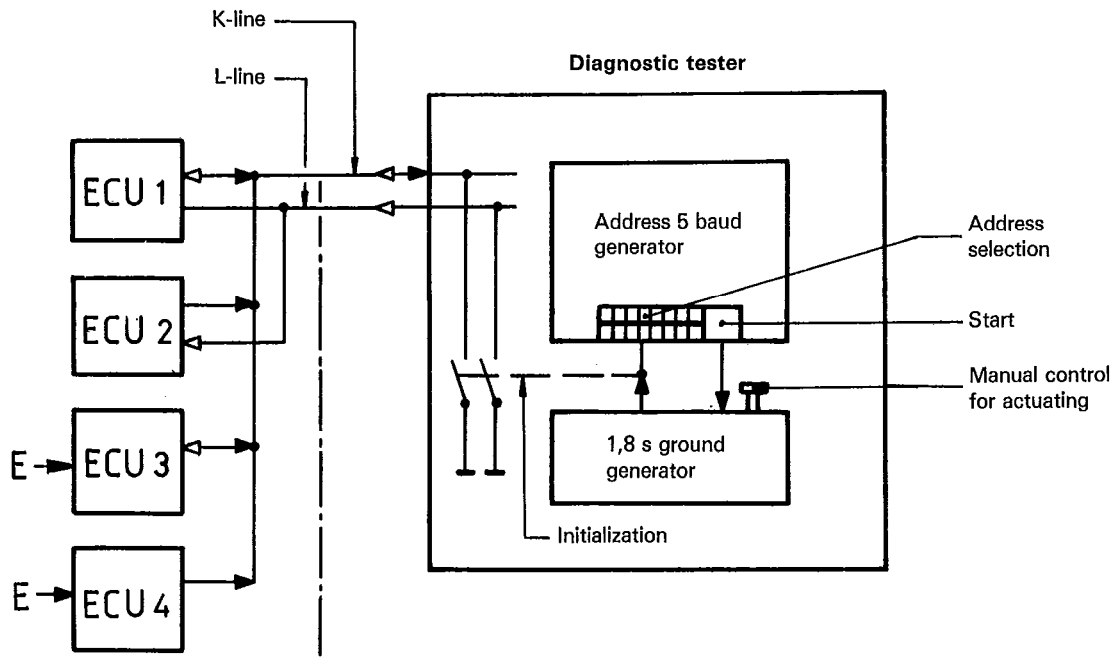

- Direction of data flow on the K-line for diagnosis
- ← Direction of data flow initialization command included from diagnostic tester to ECU either on the K- or L-line
- E Means external initialization

ECU solution Nos. 1 and 2:

When these types are connected on a bus, particular means of comparing signals between lines K and L are necessary in order to avoid unintended initialization.

ECU solution Nos. 3 and 4:

These types cannot be connected on a diagnostic bus unless separate wake-up lines exist or specific means prevent unintended initialization of any ECU by the exchange of data.

Figure 2 – Bus system of various types of ECU

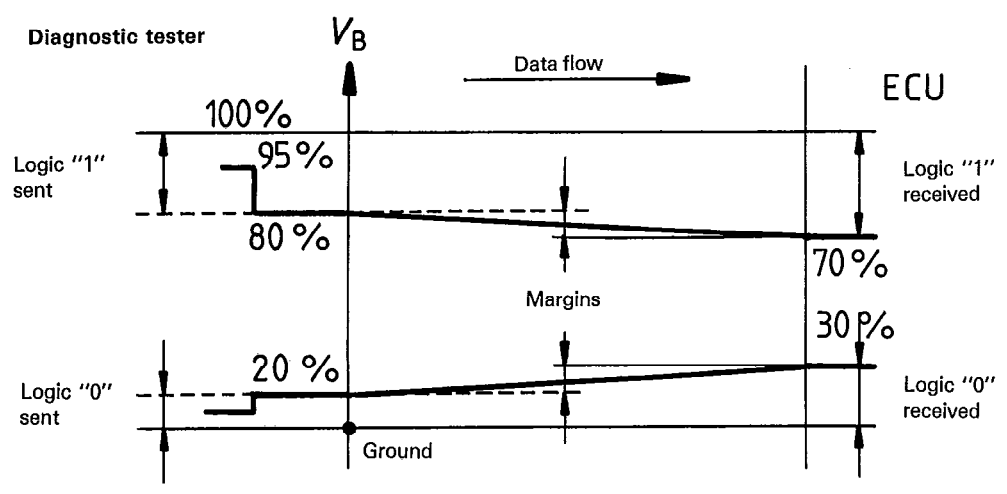

Figure 3 – Signal voltage levels, data flow from the diagnostic tester to ECU: worst-case values

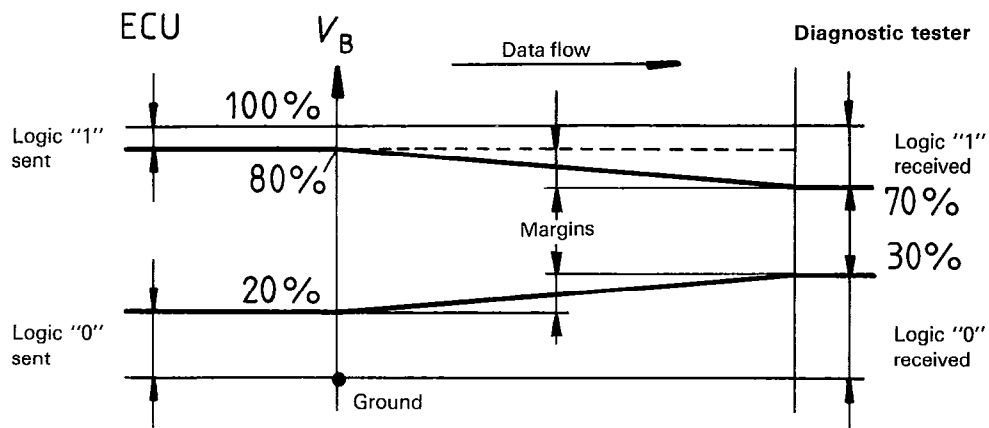

Figure 4 — Signal voltage levels, data flow from ECU to the diagnostic tester: worst-case values

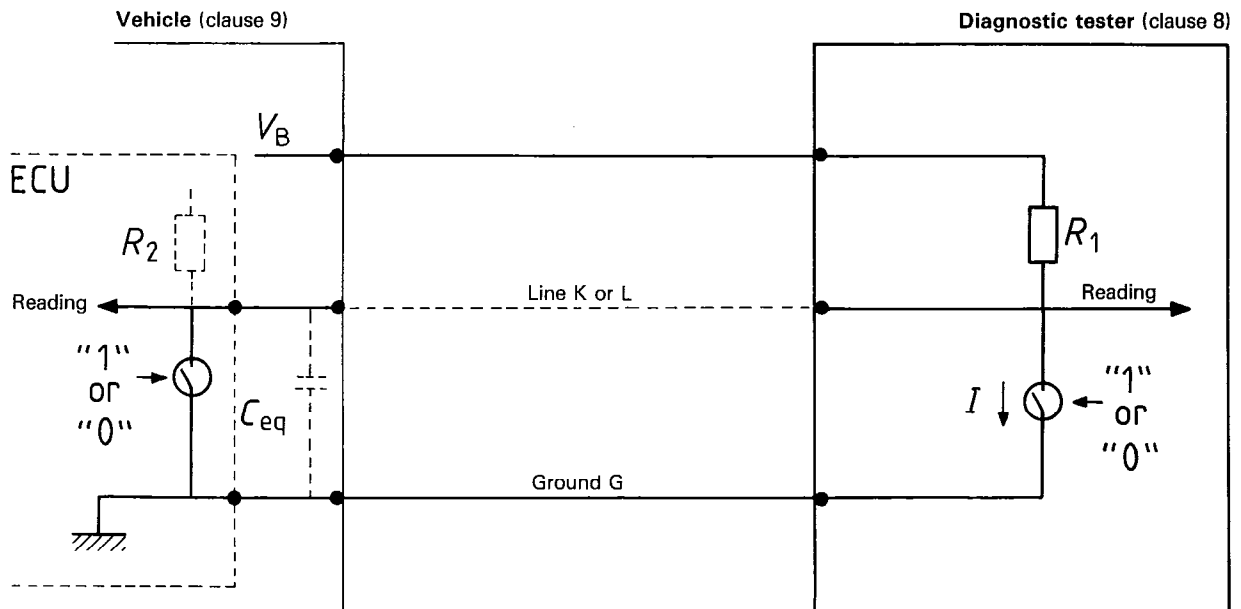

Figure 5 — Communication — Schematics

6 Initialization of the ECU prior to serial communication

For those ECUs which require initialization in order to communicate with the diagnostic tester, this initialization may be achieved by one of the following:

- through specific external means other than line K or line L (e.g. a configuration of sensors, push-buttons or turning the ignition key to "on");
- through an initialization signal output from the diagnostic tester which may be one of the following:

a) a logic "0" of duration $1,8s \pm 0,01s$ on lines K and L simultaneously, or on line K or L; this time is chosen to

distinguish it from the maximum logic "0" duration of the 5 baud address and the minimum period of grounding by wire;

b) a 5 baud address code which shall comprise a one-byte word constructed as the key word on lines K and L simultaneously, or on line K or L;

NOTE — The ECU may recognize an initialization signal on line K, or L, or both.

- through a ground connection applied to lines K and/or L for a duration greater than 2 s.

These choices are shown in figure 6.

Alternatively, the communication may be free-running (not requiring initialization).

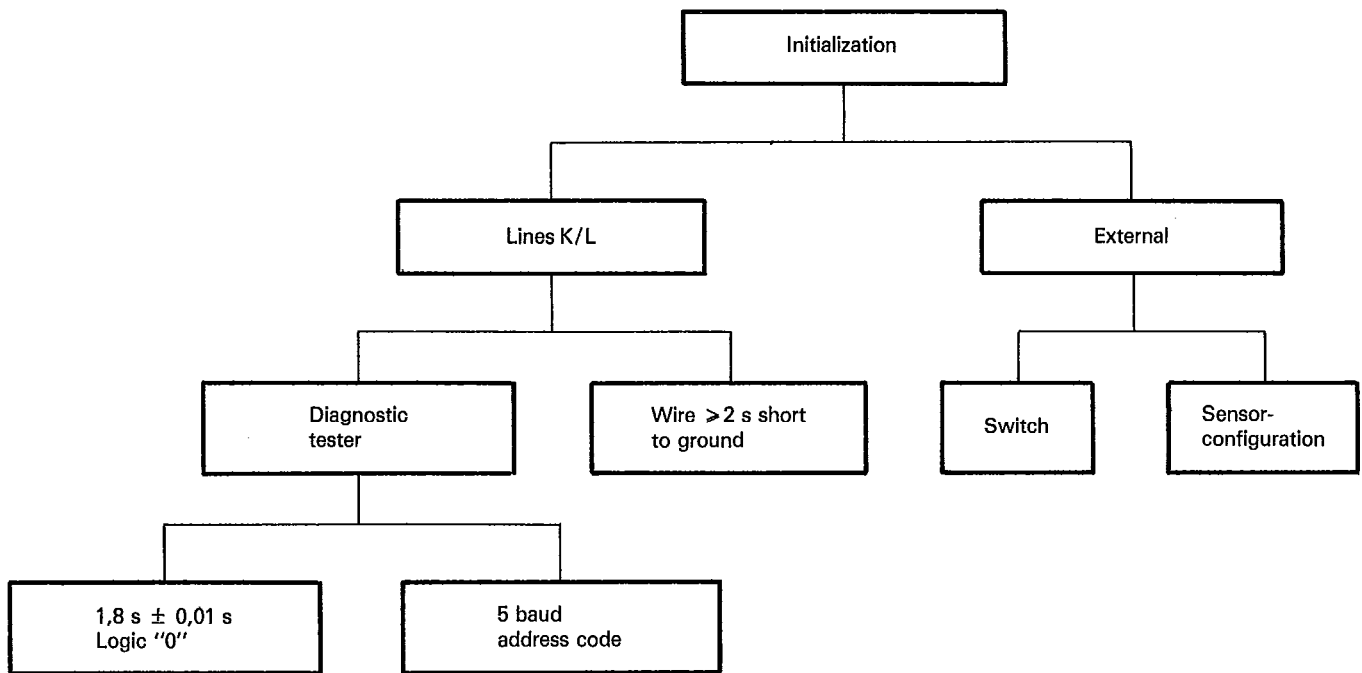

Figure 6 – Initialization

7 Header

7.1 Purpose

The diagnostic tester requires information on the form of the subsequent diagnostic communication with the initialized ECU. This information is given by the first group of serial data transmitted by the ECU (header; see definition in 3.14) and consists of

- a baud rate synchronization pattern which defines the rate of subsequent key words; and
- at least two key words that form an identifier code; this code permits the diagnostic tester to retrieve the transmission parameters of the subsequent inspection, test and diagnostic data.

7.2 Baud rate synchronization pattern

Before the serial communication, the line K shall be logic "1" for either

- at least 2 ms for those ECUs initialized by ground connection of duration > 2 s or a logic "0" of duration of 1,8 s, and not connected to a bus; or
- at least 2 ms for those ECUs connected to a bus or initialized by a 5 baud address word (see 9.3).

The logic "1" shall then be followed by the baud rate synchronization pattern. This pattern informs the diagnostic tester of the baud rate used to transmit the subsequent key words. It shall consist of

- a) one start bit – logic "0" for one bit duration;

- b) eight alternate bits starting with a logic "1" bit NRZ;
- c) one stop bit – logic "1" for one bit duration;
- d) logic "1" for a minimum duration of 2 ms or the duration of one bit of the synchronization pattern, whichever is the longer, in order to allow the diagnostic tester to re-configure.

The baud rate synchronization pattern may be transmitted any number of times in succession.

7.3 Key word format

After the last baud rate synchronization pattern, two key words shall be transmitted to inform the diagnostic tester of the form of the subsequent serial communication and of the hardware configuration of the diagnostic lines. Each key word shall consist of

- a) one start bit – logic "0" for one bit duration;
- b) seven bits, the LSB being sent first;
- c) one parity bit such that the number of logic "1" bits in the byte containing the seven key bits and the said parity bit is an odd number; odd parity was chosen to distinguish between the key words and the synchronization pattern;
- d) at least one stop bit.

After the final key word there shall a logic "1" for a minimum of 2 ms to allow the diagnostic tester to reconfigure as determined by the key words. The format is shown in figure 7.

When all combinations of the 14 key bits (2 × 7) defined in b) above have been assigned, they shall be set to logic "1" and the specifications for the serial communication shall then be determined by two more key words. This procedure may be repeated any number of times.

7.4 Key word assignment

Manufacturers of vehicles, systems or ECUs who require to use key words shall submit each specific key word to FAKRA¹⁾ for validation to ensure the key word has not been used previously.

FAKRA will then duly check the proposed key word against a master data base and either approve it, or possibly propose an alternative.

Use of the same key word by more than one manufacturer is permitted provided that the specification of the serial communication is strictly identical.

Only key words which have been validated in this way shall be used for the purpose of identifying the specification of the communication.

In order to avoid unnecessary waste of the available key words, new key words shall only be used when one or more

parameters of the communication mode is changed. Further new key words shall only be requested when they are needed.

A listing of key words assigned to manufacturers shall be made available by FAKRA on request.

7.5 Time requirements

The minimum and maximum times between the start of diagnostic communication and the start of the diagnostic data are shown in figure 8 and the associated table, where

- T_0 is the time at logic "1" before initialization;
- T_1 is the time between the end of initialization and the start of the synchronization word;
- T_2 is the time between the end of the synchronization word and the start of the first key word;
- T_3 is the time between the end of a key word and the start of the next key word;
- T_4 is the time between the end of the final key word and the start of the diagnostic data.

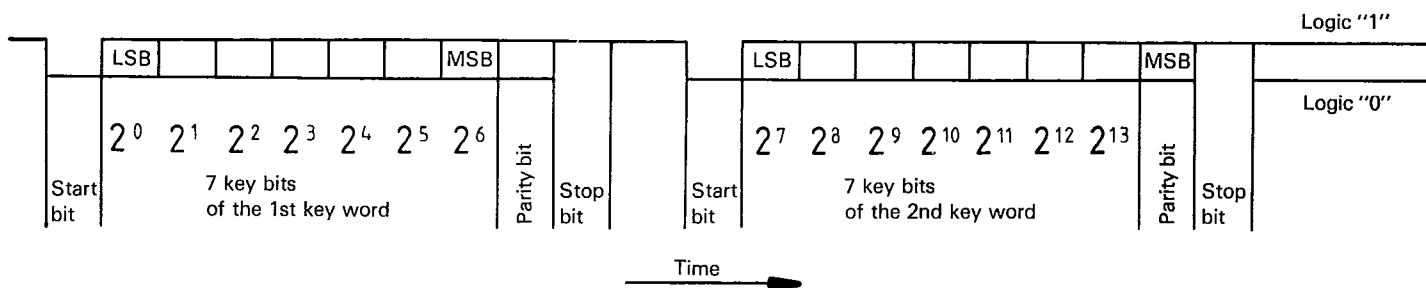
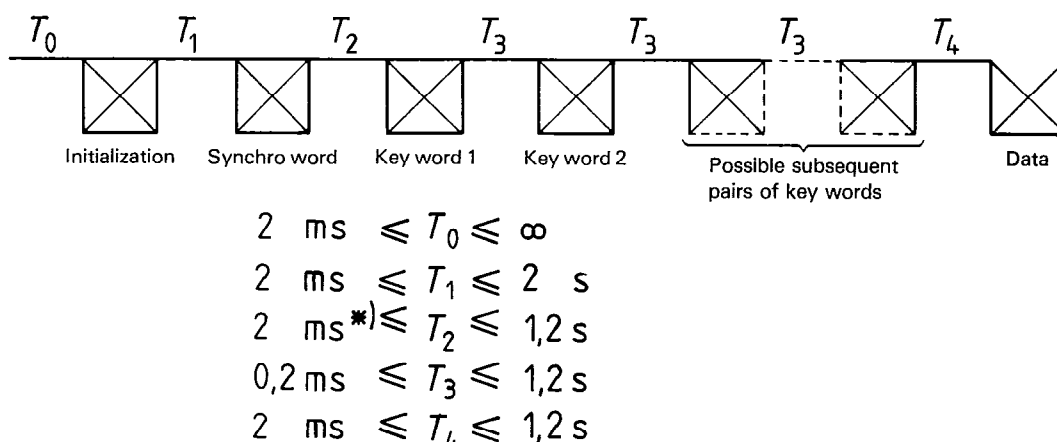

Figure 7 – Key word format



*) or 1 bit duration of the synchronization pattern, whichever is the longer.

Figure 8 – Header

1) International Agency acting under authorization from ISO: Normenausschuss Kraftfahrzeuge (FAKRA) im DIN e.V. Westendstrasse 61 D-6000 Frankfurt/Main 1

8 Requirements of the diagnostic tester

8.1 Standard connector

The connector shall have 16 ways, allocated as listed in the key to figure 9.

The diagnostic tester half of the connector (receptacle) shall have pin contacts and the loose half on the interface cable (plug) shall have socket contacts.

A polarizing key shall be used as indicated in figure 9.

Dimensions of the receptacle are shown in figure 9.

Contacts Nos. 12, 15 and 16 are free for future requirements.

A cable terminated in accordance with a specific vehicle manufacturer's instruction may also be permanently connected to the diagnostic tester. The cable shall be limited to 15 ways and the functions listed in figure 9, each function being used only once.

8.2 Input and output lines

The diagnostic tester shall have at least four lines K, L, V_B and G as previously defined in 4.1.

8.3 Facilities provided by the diagnostic tester for the ECU initialization

The diagnostic tester shall be capable of providing each of the following initialization signals on K and L lines simultaneously to the ECU:

- a) a logic "0" of duration $1,8 \text{ s} \pm 0,01 \text{ s}$;
- b) a seven-bit address code transmitted at $5 \text{ baud} \pm 0,5 \%$ and which shall comprise a one byte word of
 - one start bit — logic "0" for one bit duration;
 - seven bits containing the address, the LSB being sent first;
 - one parity bit such that the number of the logic "1" bits in the byte containing the seven address bits and the said parity bit is an odd number;
 - at least one stop bit.

NOTE — The baud rate for the address code at present is $5 \text{ baud} \pm 0,5 \%$; it may be later supplemented by a higher baud rate.

8.4 Minimum functional capabilities

The diagnostic tester shall at least be capable of

- initialization as stated in 8.3;

- determining the baud rate sent out by the ECU by means of baud rate synchronization pattern [by measuring the total duration of the eight alternate bits defined in 7.2 b)];

- reading and extracting the key words (if the key word cannot be interpreted by the diagnostic tester, it may be helpful to output these key words);

- providing means to continue the subsequent serial communication, with operator participation if required;

- responding at the required baud rate in the case of the key words specifying bidirectional communication.

This minimum level may be extended to enable the operator to perform

- interpretation and processing of the data received;
- sequencing of, and interacting with, those test procedures carried out by the diagnostic tester;
- generation of commands to the ECU to perform further tests in the ECU and/or the system or vehicle;
- change of selected data held in the ECU.

8.5 Electrical specification for the diagnostic tester of 12 V vehicle battery voltage systems

(values in parentheses refer to diagnostic tester for 24 V vehicle battery voltage systems)

These specifications shall apply over a working temperature range of $0 \text{ }^\circ\text{C}$ to $50 \text{ }^\circ\text{C}$.

The following specifications shall apply to nominal 12 V (24 V) systems for which the diagnostic tester shall operate correctly in the range 8 V to 16 V (16 V to 32 V) of the vehicle battery voltage V_B . Manufacturers of diagnostic testers are encouraged to extend the limits of correct operation for vehicle battery voltage V_B and working temperature.

8.5.1 For lines K and L of the diagnostic tester not connected to an ECU, but each internally pulled-up to V_B via nominal $510 \text{ } \Omega$ (1 k Ω):

Transmission state

- At logic "1" the diagnostic tester shall have an equivalent voltage source greater than 95 % V_B sourced from the vehicle positive voltage V_B , and an equivalent resistance of $510 \text{ } \Omega \pm 5 \%$ (1 k $\Omega \pm 5 \%$).

- At logic "0" the diagnostic tester shall have an equivalent voltage of less than 10 % of V_B , at a maximum sink current of 2 A.

Receiving state

- The equivalent resistance of line K of the diagnostic tester shall be $510 \text{ } \Omega \pm 5 \%$ (1 k $\Omega \pm 5 \%$) pulled up to V_B .

8.5.2 The diagnostic tester shall be capable of responding to the baud rate sent out by the ECU at the same baud rate within a tolerance of $\pm 1\%$ when bidirectional communication is required.

8.5.3 In case of baud rate modification through the key words, the diagnostic tester shall be capable of transmitting data to the ECU at the modified baud rate within a tolerance $\pm 0,5\%$.

8.5.4 For each word, the diagnostic tester shall be capable of determining the status of any bit the transitions of which are shifted by not more than 30 % of the bit time relative to their calculated position in time.

8.5.5 The diagnostic tester shall not transfer to the open lines K and L any voltage higher than V_B or + 40 V, whichever is the lower, or any voltage which is lower than -1 V. This includes suppression of voltage excursions of V_B as detailed in ISO/TR 7637-0.

9 Requirements of the ECU

9.1 Input and output lines

ECUs shall have one (K) or two (K and L) connections as defined in 4.1. V_B and G shall also be made available to the diagnostic tester, but need not come directly from the ECU.

9.2 Electrical specifications for ECUs in 12 V vehicle battery systems (values in parentheses refer to ECUs in 24 V vehicle battery systems)

9.2.1 Line K

At logic "1", or in receiving state, the ECU shall behave like a resistance to ground of at least $5\text{ k}\Omega \times n$ ($10\text{ k}\Omega \times n$), where n is the number of ECUs on the bus.

If an internal pull-up resistor is used between line K and V_B , the value shall not be less than $10\text{ k}\Omega \times n$ ($20\text{ k}\Omega \times n$).

The capacitance of line K with respect to ground of the ECUs anticipated on the bus shall not exceed the value determined by the formula

$$C_{\text{ECU}} = \frac{\frac{10^{-4}}{\text{BR}} - C_{\text{OBW}} - 2 \times 10^{-9}}{n}$$

$$\left(C_{\text{ECU}} = \frac{\frac{0,5 \times 10^{-4}}{\text{BR}} - C_{\text{OBW}} - 2 \times 10^{-9}}{n} \right)$$

where

capacitance is in farads;

n is the anticipated number of ECUs on the bus.

At logic "0" the ECU shall have an equivalent sink resistance not more than $110\ \Omega$ ($220\ \Omega$) between line K and ground. In addition the sink resistance shall be designed so that the slope time of the falling edge is as in 5.1.

If any other internal pull-up arrangement than that defined is used, for example an active or parasitic pull-up, care shall be taken to ensure compliance with the specifications in clause 5.

When the serial communication of the ECU is not in operation and the diagnostic tester connected, the output of the ECU shall not be at logic "0". The communication of the ECU may operate in a restricted supply voltage range. However, when this ECU is connected to a bus the ECU shall output a logic "1" when its supply voltage is outside its specified range.

9.2.2 Line L

The input resistance to ground shall not be less than $5\text{ k}\Omega \times n$ ($10\text{ k}\Omega \times n$) even if the ECU is not in operation.

The capacitance of line L with respect to ground of the ECU shall not exceed the value determined by the formula

$$C_{\text{ECU}} = \frac{\frac{10^{-4}}{\text{BR}} - C_{\text{OBW}} - 2 \times 10^{-9}}{n}$$

$$\left(C_{\text{ECU}} = \frac{\frac{0,5 \times 10^{-4}}{\text{BR}} - C_{\text{OBW}} - 2 \times 10^{-9}}{n} \right)$$

where

capacitance is in farads;

n is the anticipated number of ECUs on the bus.

9.2.3 Lines K and L

The input/output circuitry of the ECUs shall withstand transients and overvoltage present on the diagnostic tester lines K and L via the diagnostic tester source resistance, limited to

- 1 V to + 40 V (- 1 V to + 60 V)

The input/output circuitry of the ECUs shall withstand permanent short-circuit to supply voltage as specified above, and to ground.

The baud rate, averaged over a word, of the signal transmitted and/or received by the ECU shall not deviate from either the initially transmitted baud rate synchronization pattern or the nominal value redefined through the key words by more than

$$\frac{20}{B} - q (\%)$$

where

in the case of NRZ, B is the sum of the data bits including parity in a word plus 1, and in the case of self-contained clock code B is 1;

q is 0,5 in the case of key word redefined baud rate, and q is 1 in the case of non-redefined baud rate and of the baud rate synchronization pattern (eight alternate bits).

The position of any bit transition shall be allowed to deviate by up to 20 % of the bit time, relative to its calculated position in time defined by the baud rate.

9.3 Recognition of an initialization address

When an ECU is initialized by a 5 baud word it shall wait at least 2 ms after decoding the stop bit before sending the baud rate synchronization pattern.

When an ECU is initialized by a logic "0" of a duration of 1,8 s and intended for use on a bus, it shall wait at least 2 ms after termination of logic "0" before sending the baud rate synchronization pattern.

10 Requirements of the wiring

The total capacitance of the diagnostic tester and its cable shall not exceed 2 nF, and that of each serial communication line built into the vehicle shall not exceed 3 nF, when measured without an ECU connected.

ISO 9141 : 1989 (E)

UDC 621.11 : 620.1 681.3

Descriptors : road vehicles, diagnosis, electronic equipment, control equipment, digital circuits, information interchange, specification.

Price based on 11 pages
