**Motorcycles — Measurement method
for location of centre of gravity**

Motorcycles — Méthode de mesure de l'emplacement du centre de gravité



Reference number
ISO 9130:2005(E)

© ISO 2005

PDF disclaimer

This PDF file may contain embedded typefaces. In accordance with Adobe's licensing policy, this file may be printed or viewed but shall not be edited unless the typefaces which are embedded are licensed to and installed on the computer performing the editing. In downloading this file, parties accept therein the responsibility of not infringing Adobe's licensing policy. The ISO Central Secretariat accepts no liability in this area.

Adobe is a trademark of Adobe Systems Incorporated.

Details of the software products used to create this PDF file can be found in the General Info relative to the file; the PDF-creation parameters were optimized for printing. Every care has been taken to ensure that the file is suitable for use by ISO member bodies. In the unlikely event that a problem relating to it is found, please inform the Central Secretariat at the address given below.

© ISO 2005

All rights reserved. Unless otherwise specified, no part of this publication may be reproduced or utilized in any form or by any means, electronic or mechanical, including photocopying and microfilm, without permission in writing from either ISO at the address below or ISO's member body in the country of the requester.

ISO copyright office
Case postale 56 • CH-1211 Geneva 20
Tel. + 41 22 749 01 11
Fax + 41 22 749 09 47
E-mail copyright@iso.org
Web www.iso.org

Published in Switzerland

Contents

Page

Foreword	iv
Introduction	v
1 Scope	1
2 Normative references	1
3 Terms and definitions	1
4 Measurement conditions	2
5 Apparatus and measuring instruments	2
6 Measuring procedure	3
7 Test results	16
Annex A (normative) Test report	17

Foreword

ISO (the International Organization for Standardization) is a worldwide federation of national standards bodies (ISO member bodies). The work of preparing International Standards is normally carried out through ISO technical committees. Each member body interested in a subject for which a technical committee has been established has the right to be represented on that committee. International organizations, governmental and non-governmental, in liaison with ISO, also take part in the work. ISO collaborates closely with the International Electrotechnical Commission (IEC) on all matters of electrotechnical standardization.

International Standards are drafted in accordance with the rules given in the ISO/IEC Directives, Part 2.

The main task of technical committees is to prepare International Standards. Draft International Standards adopted by the technical committees are circulated to the member bodies for voting. Publication as an International Standard requires approval by at least 75 % of the member bodies casting a vote.

Attention is drawn to the possibility that some of the elements of this document may be the subject of patent rights. ISO shall not be held responsible for identifying any or all such patent rights.

ISO 9130 was prepared by Technical Committee ISO/TC 22, *Road vehicles*, Subcommittee SC 22, *Motorcycles*.

This second edition cancels and replaces the first edition (ISO 9130:1989), which has been technically revised.

Introduction

The stability of a motorcycle is a very important element of its active safety. The motorcycle–rider combination and the environment in which this combination is used form a unique closed-loop system. However, the evaluation of the motorcycle–rider combination stability is extremely complex because of the interaction between the intrinsic motorcycle stability, the influence of the rider's position and his/her response to continuously changing conditions.

In the evaluation of motorcycle stability, the determination of the kinetic characteristics of the motorcycle–rider combination is to be considered an important part of the design parameters of the vehicle itself.

The test procedure specified in this International Standard deals with one aspect of the kinetic characteristics: the determination of the centre of gravity of the motorcycle and of the motorcycle–rider combination.

Motorcycles — Measurement method for location of centre of gravity

1 Scope

This International Standard specifies a measuring method for determining the location of the centre of gravity of the motorcycle and of the motorcycle–rider combination. It is applicable to two-wheeled motorcycles.

Other measuring methods can be used if it is demonstrated that the results are equivalent.

The measuring results obtained by the method given in this International Standard alone (see Annex A) cannot be used for an evaluation of the vehicle stability because they deal with only one aspect of this very complex phenomenon.

2 Normative references

The following referenced documents are indispensable for the application of this document. For dated references, only the edition cited applies. For undated references, the latest edition of the referenced document (including any amendments) applies.

ISO 3779, *Road vehicles — Vehicle identification number (VIN) — Content and structure*

49 CFR Part 572, subpart B, *Code of Federal Regulations*. NHTSA¹⁾

3 Terms and definitions

For the purposes of this document, the following terms and definitions apply.

3.1 motorcycle axis system

x, y, z

right-hand orthogonal axis system fixed on the motorcycle such that when the motorcycle is moving in a straight line on a level road, the x -axis is substantially horizontal, points forwards and is in the longitudinal plane of symmetry, the y -axis points to the rider's left side and the z -axis points upwards

NOTE 1 This coordinate system applies to translation motion and rotational motion together with the motorcycle.

NOTE 2 Assuming the condition that the motorcycle is fixed to the platform, the coordinate system is also applied to the platform.

3.2 earth-fixed axis system

X, Y, Z

right-hand orthogonal axis system fixed on the Earth, such that the X - and Y -axes are in a horizontal plane and the Z -axis points upwards

1) US National Highway Traffic Safety Administration.

4 Measurement conditions

4.1 Measurement conditions for a riderless motorcycle are as follows.

- a) The motorcycle shall be free from mud and deformation, and shall operate normally.
- b) The fuel shall be filled up to the top level specified in the operator's manual.
- c) Lubricating oil and cooling water shall be filled up to the level specified in the operator's manual.
- d) Tyre pressure shall be as specified in the operator's manual.
- e) Tools shall be provided at the regular storage positions.
- f) Front and rear suspension systems shall be fixed at a static position.
- g) The front wheel shall be positioned along the x -axis.

If the conditions are to be modified according to the object of the measurement, the modified conditions shall be recorded in the measurement report.

4.2 Measurement conditions when a rider is on the motorcycle are as follows.

- a) The measurement conditions of the motorcycle shall be in accordance with 4.1.
- b) A test dummy as specified in 49 CFR Part 572, subpart B, or equivalent, having a mass of 73,4 kg, or an equivalent person, shall be used as the rider.
- c) The rider should be positioned on the vertical centre surface of the motorcycle.
- d) The rider shall sit on the seat, hold the handle bar by both hands, and place both feet on the foot rests.
- e) The rider shall be positioned so as to obtain the angle formed by the line connecting point S (the point indicating the centre of rotation of the torso and the arms of the rider) and point H (the point indicating the centre of rotation of the torso and femoral regions of the rider) and the x -axis. This angle shall be the angle of the rider's posture.
- f) The rider shall be positioned so as to obtain the distance between the front axle and point H along the x -axis, which shall be the seating position of the rider.

If the conditions are to be modified according to the object of measurement, the modified conditions shall be recorded in the measurement report.

5 Apparatus and measuring instruments

- 5.1 **Precision square level**, able to measure up to 0,1mm / 1m (\approx 20 inches).
- 5.2 **Steel tape measure** with a tolerance of $\pm [0,3 + 0,1(L - 1)]$ mm at length, L , in metres.
- 5.3 **Angle gauge**, able to measure the rotational angle to $0,1^\circ$ electrically or mechanically.
- 5.4 **Weighing scales**, with sufficient accuracy to weigh the object up to 0,1 kg.
- 5.5 **Supports**, used when placing the platform on the weighing scale.
- 5.6 **Platform**, being of the highest possible rigidity and of light weight.

5.7 Knife-edge, the roundness at the edge of which shall be less than 1 mm in radius and whose edge angle should be less than 90°. The roundness at the edge is the form of edge finished sharply when rounded with the load applied to it.

5.8 Weights, used to incline the platform.

6 Measuring procedure

6.1 Location of centre of gravity along x -axis

6.1.1 Location of centre of gravity of the empty platform along x -axis

Measure the location of the centre of gravity of the empty platform along the x -axis, as follows. See Figure 1.

- a) Place supports respectively at the centres of the front and rear weighing scales and measure loads P_{KF} and P_{KR} .
- b) Place the platform on the two supports, such that its centre of gravity lies directly above the line connecting the two supports. The platform includes any brackets/wires necessary to hold the motorcycle. If it is difficult to locate the centre of gravity above the line connecting the two supports, use additional sets of a weighing scale and a support, such that the centre of gravity falls on the area framed by additional supports and the supports F and R.
- c) Measure the distance, x_{PF} , along the x -axis from point A at the front end of the platform to support F on the front side, and the distance x_{PR} along the x -axis from point A to support R on the rear side.
- d) Measure loads P_{FR} and P_{RR} distributed to the front and rear supports.
- e) Calculate the distance, x_P , along the x -axis from point A at the front end of the platform to the centre of gravity using Equations (1) to (3):

$$P_{PF} = P_{FR} - P_{KF} \quad (1)$$

$$P_{PR} = P_{RR} - P_{KR} \quad (2)$$

$$x_P = \frac{x_{PF}P_{PF} + x_{PR}P_{PR}}{P_{PF} + P_{PR}} \quad (3)$$

where

P_{PF} is the load of platform distributed to support F, in newtons (N);

P_{PR} is the load of platform distributed to support R, in newtons (N);

P_{FR} is the total of the load given by the platform and the load given by support F, distributed to support F, in newtons (N);

P_{RR} is the total of the load given by the platform and the load given by support R, distributed to support R, in newtons (N);

P_{KF} is the load of support F, in newtons (N);

P_{KR} is the load of support R, in newtons (N);

x_P is the distance from point A at the front end of the platform to the centre of gravity along the x -axis, in millimetres (mm);

x_{PF} is the distance from point A at the front end of the platform to the support F along the x -axis, in millimetres (mm);

x_{PR} is the distance from point A at the front end of the platform to support R along the x -axis, in millimetres (mm).

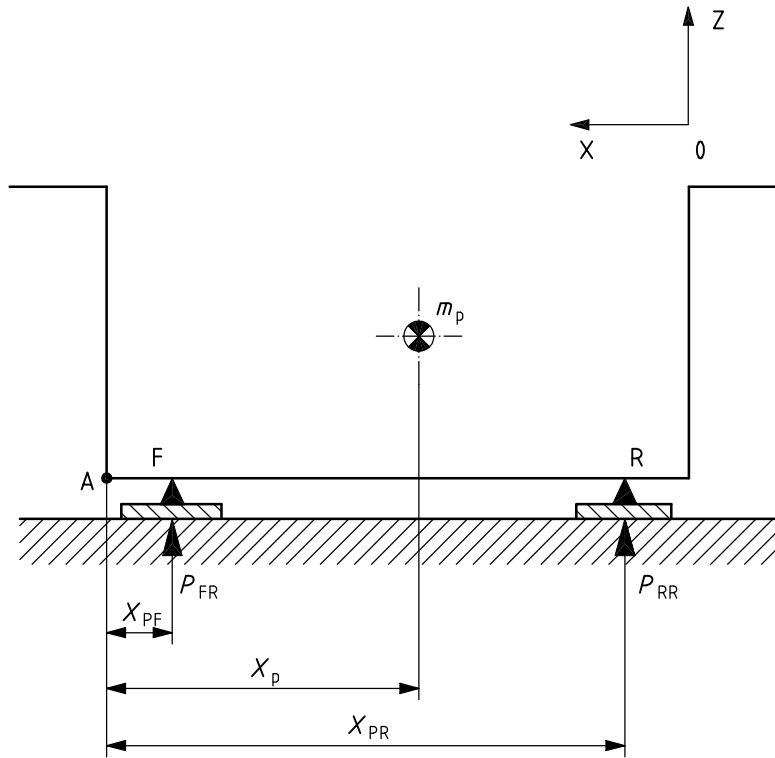

Figure 1 — Location of centre of gravity of platform along x -axis

6.1.2 Location of centre of gravity of motorcycle along x -axis

For both the case where the motorcycle is riderless (4.1) or has a rider seated on it (4.2), measure the location of the centre of gravity of a motorcycle along the x -axis, as follows. See Figure 2.

- Place the motorcycle on the platform, such that the tyre centrelines are parallel to, and vertical above, the line connecting the two supports, and fix it so it cannot move. The lateral inclination angle of the motorcycle to the platform shall be $0^\circ \pm 0,5^\circ$.
- Measure the distance, x_F , along the x -axis from point A at the front end of the platform to the front axle of the motorcycle.
- Measure loads P_{MF} and P_{MR} distributed to the front and rear supports.
- Calculate the distance, x_g , along the x -axis from the front axle of the motorcycle to the location of the centre of gravity using Equations (4) to (9):

$$m_m = m_T - m_P \quad (4)$$

$$P_{TF} = P_{MF} - P_{KF} \quad (5)$$

$$P_{TR} = P_{MR} - P_{KR} \quad (6)$$

$$x_T = \frac{x_{PF}P_{TF} + x_{PR}P_{TR}}{P_{TF} + P_{TR}} \quad (7)$$

$$x_m = \frac{x_T m_T - x_P m_P}{m_m} \quad (8)$$

$$x_g = x_m - x_F \quad (9)$$

where

m_m is the mass of the motorcycle, in kilograms (kg);

m_T is the total mass of the motorcycle and platform, in kilograms (kg);

m_P is the mass of the platform, in kilograms (kg);

P_{TF} is the load of the platform and motorcycle distributed to support F, in newtons (N);

P_{TR} is the load of the platform and motorcycle distributed to support R, in newtons (N);

P_{MF} is the total of the load given by platform and motorcycle and the load given by support F, distributed to support F, in newtons (N);

P_{MR} is the total of the load given by platform and motorcycle, and the load given by support R, distributed to support R, in newtons (N);

x_T is the distance from point A at the front end of the platform to the centre of gravity of both motorcycle and platform along the x -axis, in millimetres (mm);

x_m is the distance from point A at the front end of the platform to the centre of gravity of the motorcycle along the x -axis, in millimetres (mm);

x_g is the distance from the front axle of the motorcycle to the centre of gravity along the x -axis, in millimetres (mm);

x_F is the distance from point A at the front end of the platform to the front axle of the motorcycle along the x -axis, in millimetres (mm).

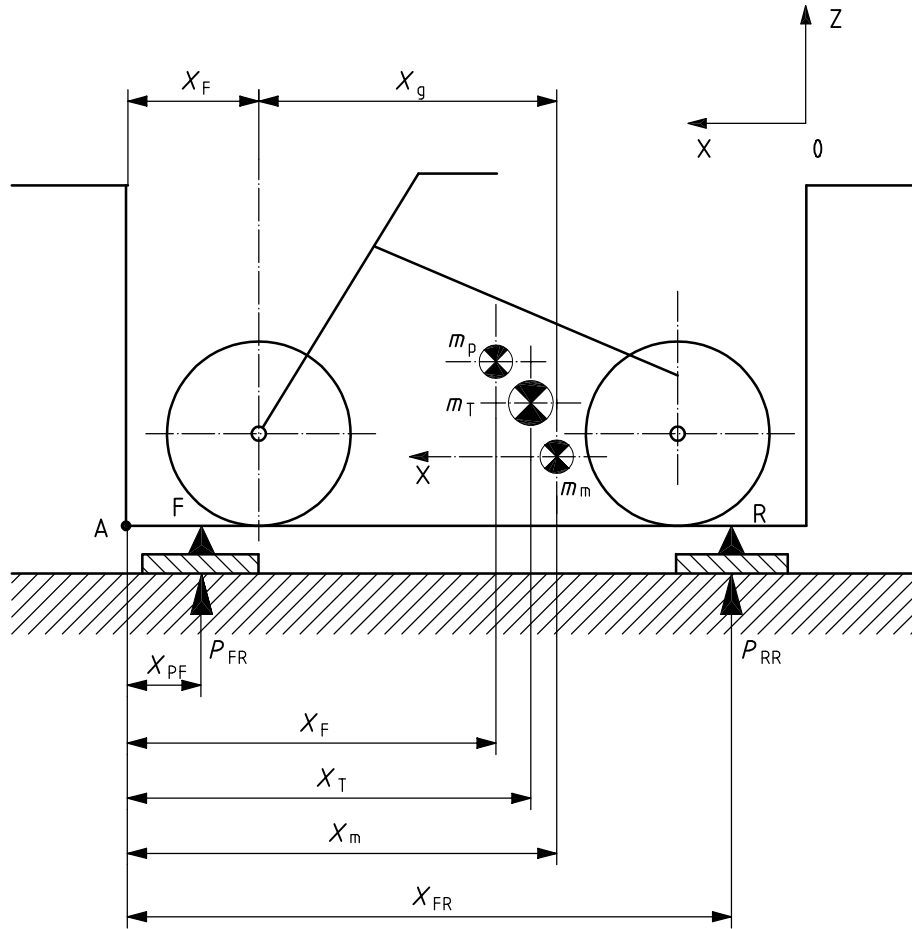

Figure 2 — Location of centre of gravity of motorcycle along x-axis

6.2 Location of centre of gravity along y-axis

6.2.1 Location of centre of gravity of the empty platform along y-axis

Measure the location of the centre of gravity of the empty platform along the y-axis, as follows. See Figure 3.

- Place supports at the centres of the right and left weighing scales and measure loads P_{KL} and P_{KR} .
- Place the platform on the two supports, such that its centre of gravity lies directly above the line connecting the two supports. The platform includes any brackets/wires necessary to hold the motorcycle. If it is difficult to locate the centre of gravity above the line connecting the two supports, use additional sets of a weighing scale and a support, such that the centre of the gravity falls on the area framed by additional supports and supports L and R.
- Measure the distance, y_{PL} , along the y-axis from point B at the left end of the platform to support L on the left side; measure the distance, y_{PR} , along the y-axis from point B to support R on the right side.
- Measure loads P_L and P_R distributed to the left and right supports.
- Calculate the distance, y_p , along the y-axis from point B at the left end of the platform to the centre of gravity using Equations (10) to (12):

$$P_{PL} = P_L - P_{KL} \tag{10}$$

$$P_{PR} = P_R - P_{KL} \tag{11}$$

$$y_P = \frac{y_{PL}P_{PL} + y_{PR}P_{PR}}{P_{PL} + P_{PR}} \tag{12}$$

where

P_{PL} is the load of the platform distributed to support L, in newtons (N);

P_{PR} is the load of the platform distributed to support R, in newtons (N);

P_L is the total of the load given by the platform and the load given by support L, distributed to support L, in newtons (N);

P_R is the total of the load given by the platform and the load given by support R, distributed to support R, in newtons (N);

P_{KL} is the load of support L, in newtons (N);

P_{KR} is the load of support R, in newtons (N);

y_P is the distance from point B at the left end of the platform to the centre of gravity along the y -axis, in millimetres (mm);

y_{PL} is the distance from point B at the left end of the platform to the support L along the y -axis, in millimetres (mm);

y_{PR} is the distance from point B at the left end of the platform to support R along the y -axis, in millimetres (mm).

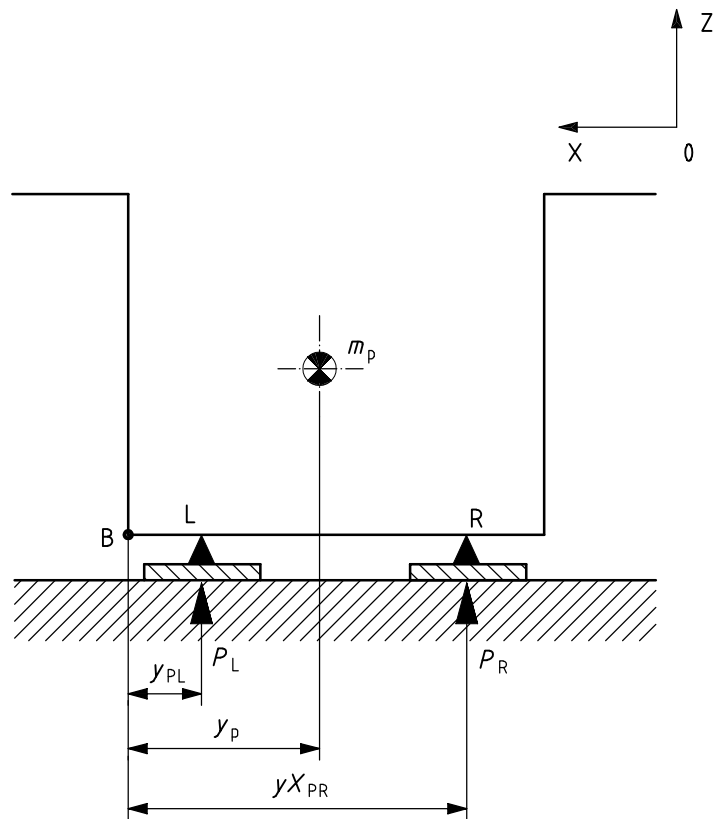

Figure 3 — Location of centre of gravity of platform along y -axis

6.2.2 Location of centre of gravity of motorcycle along y -axis

For both the case where the motorcycle is riderless (4.1) or has a rider seated on it (4.2), measure the location of the centre of gravity of the motorcycle along the x -axis, as follows. See Figure 4.

- a) Place the motorcycle on the platform, such that the measured location of the centre of gravity along the motorcycle x -axis is directly above the line connecting the two supports and the tyre centrelines are perpendicular to the line connecting the two supports, and fix it so it cannot move. Lateral inclination angle of the motorcycle to the platform shall be $0^\circ \pm 0,5^\circ$.
- b) Measure the distance, y_0 , along the y -axis from point B at the left end of the platform to the vertical centre surface of the motorcycle.
- c) Measure loads P_{ML} and P_{MR} distributed to the left and right supports.
- d) Calculate the distance, y_g , along the y -axis from the vertical centre surface of the motorcycle to the location of the centre of gravity using Equations (13) to (18):

$$m_m = m_T - m_P \tag{13}$$

$$P_{TL} = P_{ML} - P_{KL} \tag{14}$$

$$P_{TR} = P_{MR} - P_{KR} \tag{15}$$

$$y_T = \frac{y_{PL}P_{TL} + y_{PR}P_{TR}}{P_{TL} + P_{TR}} \tag{16}$$

$$y_m = \frac{y_T m_T - y_P m_P}{m_m} \tag{17}$$

$$y_g = y_0 - y_m \tag{18}$$

where

- m_m is the mass of the motorcycle, in kilograms (kg);
- m_T is the total mass of the motorcycle and platform, in kilograms (kg);
- m_P is the mass of the platform, in kilograms (kg);
- P_{TL} is the load of the platform and motorcycle distributed to support L, in newtons (N);
- P_{TR} is the load of the platform and motorcycle distributed to support R, in newtons (N);
- P_{ML} is the total of the load given by platform and motorcycle and the load given by support L, distributed to support L, in newtons (N);
- P_{MR} is the total of the load given by platform and motorcycle and the load given by support R, distributed to support R, in newtons (N);
- y_T is the distance from point B at the left end of the platform to the centre of gravity of both motorcycle and platform along the y -axis, in millimetres (mm);
- y_m is the distance from point B at the left end of the platform to the centre of gravity of the motorcycle along the y -axis, in millimetres (mm);
- y_g is the distance from the vertical centre surface of the motorcycle to the centre of gravity along the y -axis, in millimetres (mm);

y_0 is the distance from point B at the left end of the platform to the vertical centre surface of the motorcycle along the y -axis, in millimetres (mm).

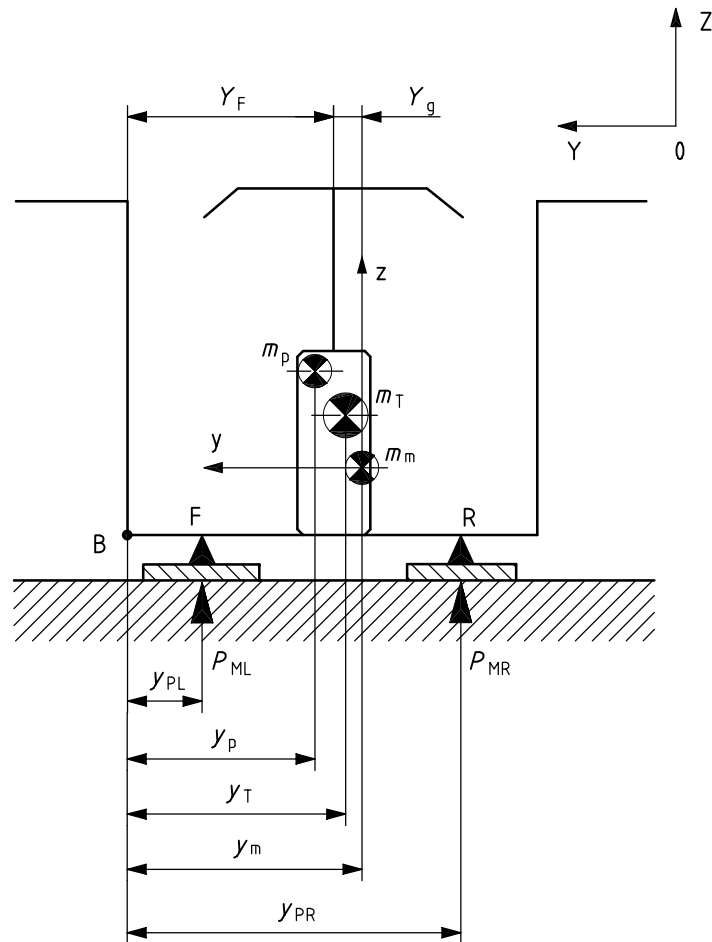

Figure 4 — Location of centre of gravity of motorcycle along y -axis

6.3 Location of centre of gravity along z -axis

6.3.1 Location of centre of gravity of the empty platform along z -axis

Measure the location of the centre of gravity of the empty platform along the z -axis, as follows. See Figures 5 and 6.

- Measure the distance, h_0 , from the bottom surface of the platform on which the motorcycle is to be placed to the knife-edge along the z -axis.
- Measure distances a_0 and b_0 from the knife-edge to point C at the position at which is suspended the weight of mass m_{k1} [see d)] along the x - and z -axes respectively.
- Place the platform on the knife-edge of the stay and measure the angle θ_p formed by the platform bottom surface and the horizontal surface. At this time, the calculation equation for the location of the centre of gravity according to e), below, will vary depending on the platform inclination direction.
- Suspend a weight of mass m_{k1} from point C of the platform so that the point C side of the platform is lower and measure the angle, θ_k , formed by the platform's bottom surface and the horizontal surface [Figures 5 b) and 6 b)]. As inclination angle θ_k increases, the value of the location of centre of gravity

along the z -axis becomes stable and the measurement error decreases. The inclination should be greater than 10° .

- e) Calculate the distance, z_P , from the platform bottom surface to the centre of gravity along the z -axis using Equations (19) and (20). For the \pm symbols in the equation, use the negative if the point C side is lower when measuring θ_P [(Figure 5 a)] and use the positive when the point C side is raised [Figure 6 a]:

$$c_P = \frac{m_{K1} (a_0 + b_0 \tan \theta_K)}{m_P (\tan \theta_K \pm \tan \theta_P)} \quad (19)$$

$$z_P = h_0 - c_P \quad (20)$$

where

- c_P is the distance from the knife-edge to the centre of gravity of the platform along the z -axis, in millimetres (mm);
- m_{K1} is the mass of weight suspended from the platform, in kilograms (kg);
- a_0 is the distance along the x -axis from the knife-edge to point C, at which the weight is suspended, in millimetres (mm);
- b_0 is the distance along the z -axis from the knife-edge to point C, at which the weight is suspended, in millimetres (mm);
- θ_K is the angle, in degrees, formed by the platform bottom surface and the horizontal surface with the platform placed on the knife-edge and weight suspended, absolute value;
- m_P is the mass of platform, in kilograms (kg);
- θ_P is the angle, in degrees, formed by the platform bottom surface and the horizontal surface with the platform placed on the knife-edge and no weight suspended, absolute value;
- z_P is the distance from the platform's bottom surface to the centre of gravity along the z -axis, in millimetres (mm);
- h_0 is the distance from the platform's bottom surface to the knife-edge along the z -axis, in millimetres (mm).

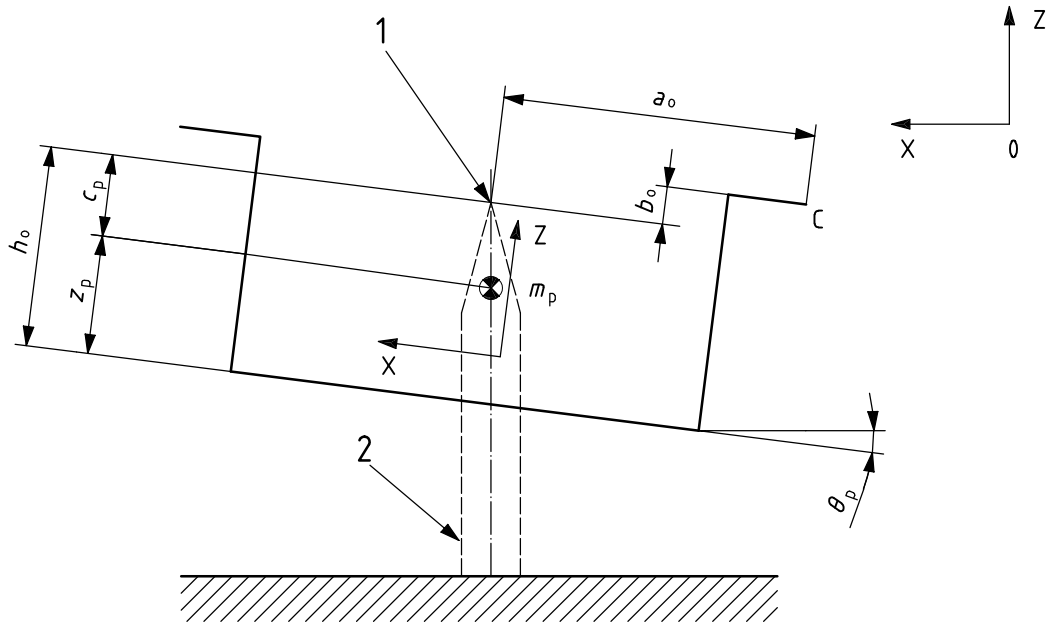

a) Measurement of θ_P

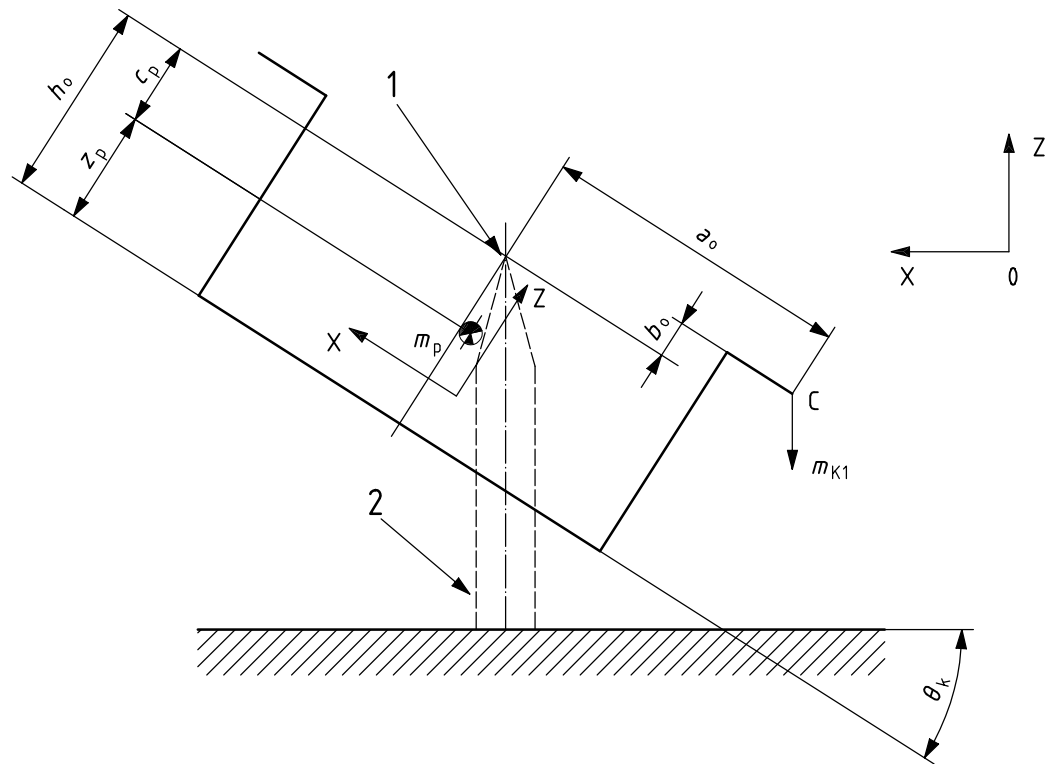

b) Measurement of θ_K

Key

- 1 knife-edge
- 2 stay

Figure 5 — Location of centre of gravity of platform along z-axis (point C side lowered)

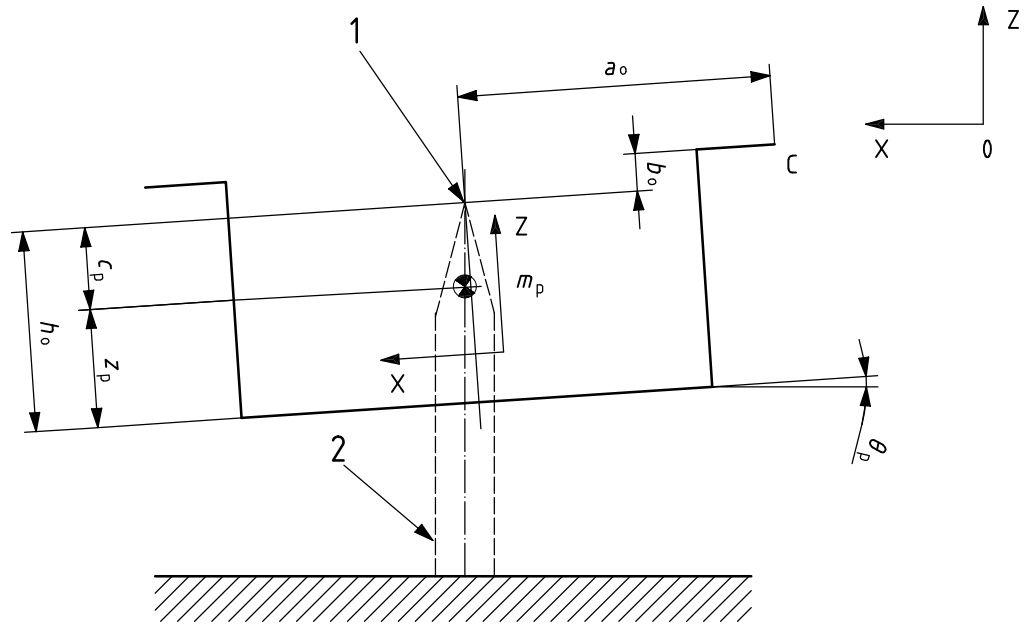

a) Measurement of θ_p

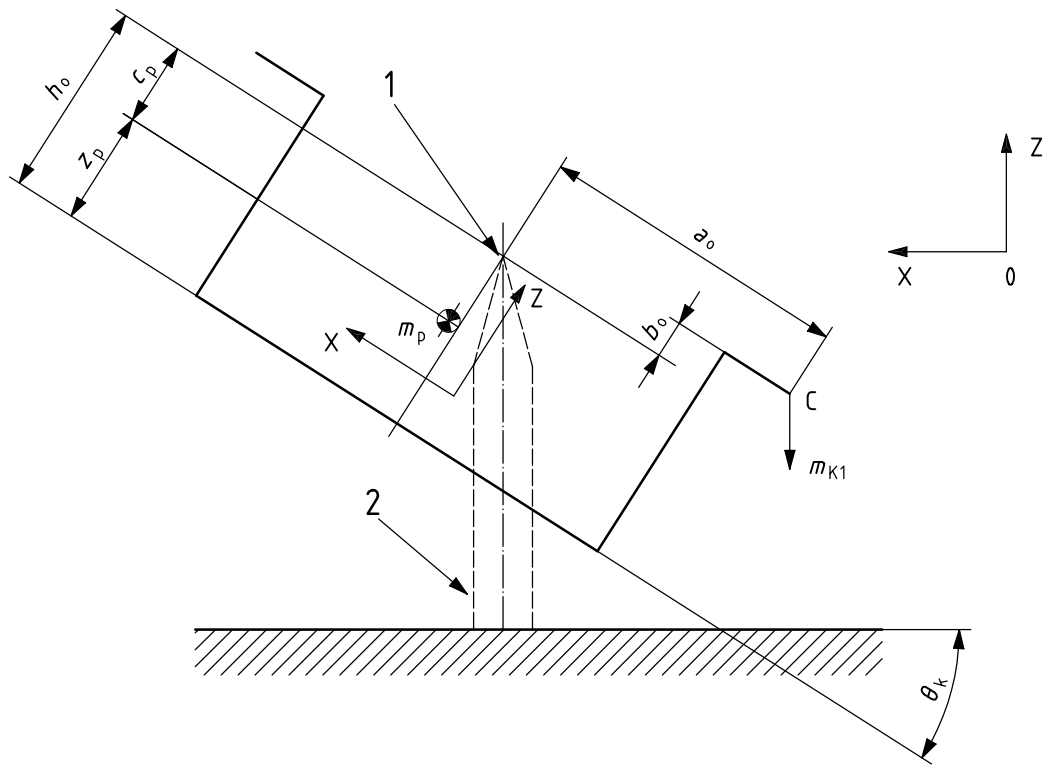

b) Measurement of θ_k

- Key**
 1 knife-edge
 2 stay

Figure 6 — Location of centre of gravity of platform along z-axis (point C side raised)

6.3.2 Location of centre of gravity of motorcycle along z -axis

For both the case where the motorcycle is riderless (4.1) or has a rider seated on it (4.2), measure the location of the centre of gravity of the motorcycle along the z -axis, as follows (see Figures 7 and 8).

- Place the motorcycle on the platform and fix it so it cannot move. Lateral inclination angle of the motorcycle to the platform shall be $0^\circ \pm 0,5^\circ$.
- Place the platform on the knife-edge of the stay and measure the angle, θ_T , formed by the platform bottom surface and the horizontal surface. At this time, the calculation equation for the location of the centre of gravity according to e), below, will vary depending on the platform inclination direction.
- Adjust the motorcycle fixing position so that θ_T is as small as possible.
- Suspend a weight of mass m_{k2} from point C of the platform and measure the angle θ_{TK} formed by the platform's bottom surface and the horizontal surface [Figures 7 b) and 8 b)]. As inclination angle θ_{TK} increases, the value of the location of centre of gravity along the z -axis becomes stable and the measurement error decreases. The inclination should be greater than 10° .
- Calculate the distance, z_g , from the surface where the front and rear wheels of the motorcycle touch the ground to the centre of gravity along the z -axis using the following equations. For the \pm symbols in the equations, use the negative if the point C side is lower when measuring θ_T [Figure 7 a)] and use the positive when the point C side is raised [Figure 8 a)]:

$$m_T = m_P + m_{k2} + m_m \quad (21)$$

$$c_T = \frac{m_{k2} (a_0 + b_0 \tan \theta_{TK})}{(m_P + m_m) (\tan \theta_{TK} \pm \tan \theta_T)} \quad (22)$$

$$c_m = \frac{m_T c_T + m_{k2} b_0 - m_P c_P}{m_m} \quad (23)$$

$$z_g = h_0 - c_m \quad (24)$$

where

- m_T is the total mass of platform, weight and motorcycle, in kilograms (kg);
- m_{k2} is the mass of the weight suspended from the platform, in kilograms (kg);
- m_m is the mass of the motorcycle, in kilograms (kg);
- c_T is the distance from the knife-edge to the centre of gravity of both platform and motorcycle along the z -axis, in millimetres (mm);
- θ_{TK} is the angle, in degrees, formed by the platform's bottom surface and the horizontal surface, with the platform placed on the knife-edge and weight suspended, absolute value;
- θ_T is the angle, in degrees, formed by the platform's bottom surface and the horizontal surface, with the platform placed on the knife-edge and no weight suspended, absolute value;
- c_m is the distance from the knife-edge to the centre of gravity of the motorcycle along the z -axis, in millimetres (mm);
- z_g is the distance from the surface where the front and rear wheels of the motorcycle touch the ground to the centre of gravity along the z -axis, in millimetres (mm).

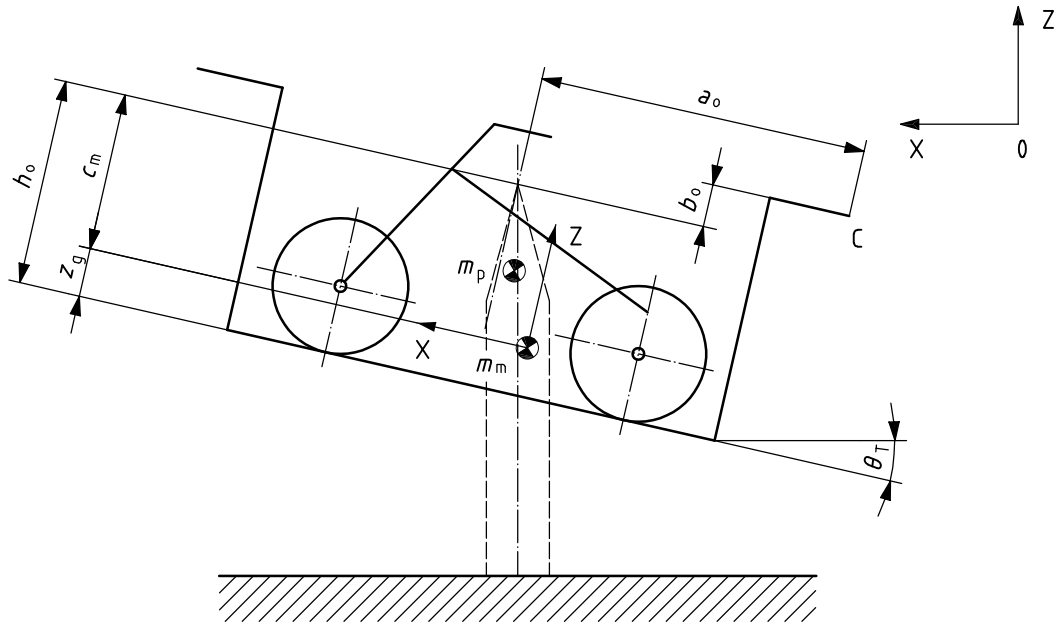

a) Measurement of θ_T

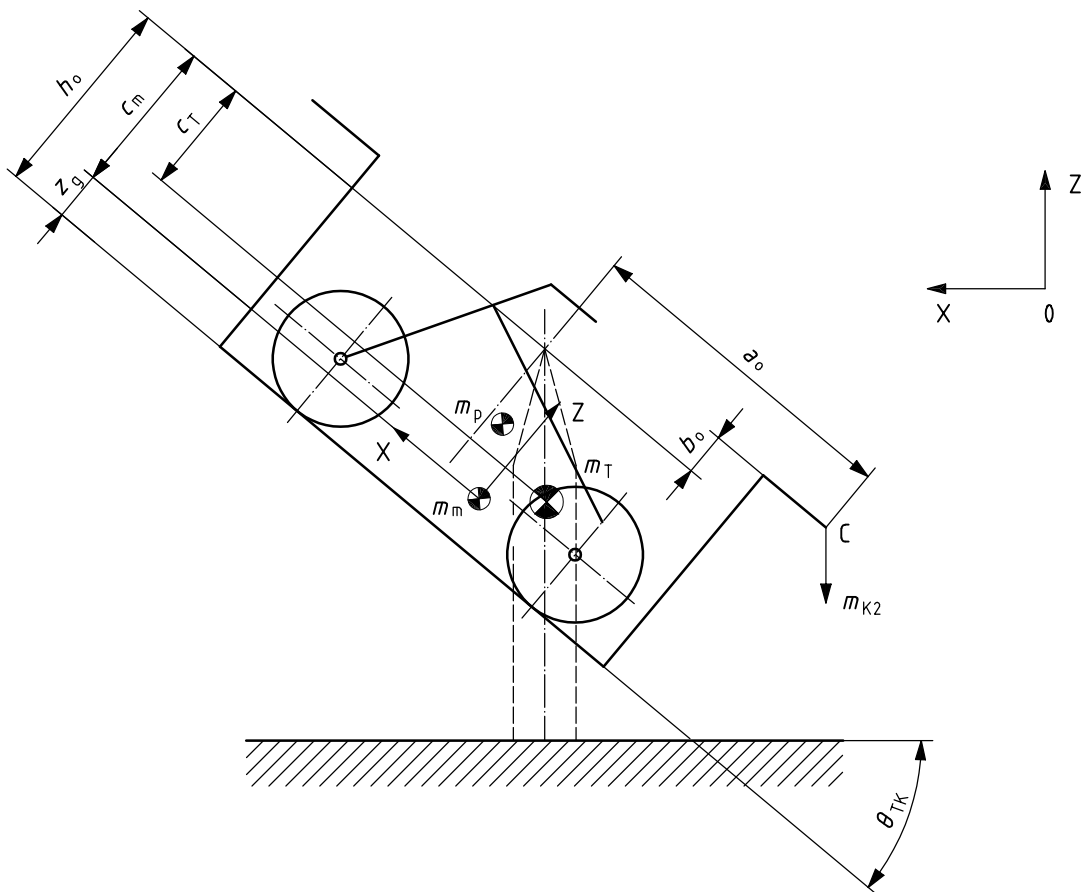

b) Measurement of θ_{TK}

Figure 7 — Location of centre of gravity of motorcycle along z-axis (point C side lowered)

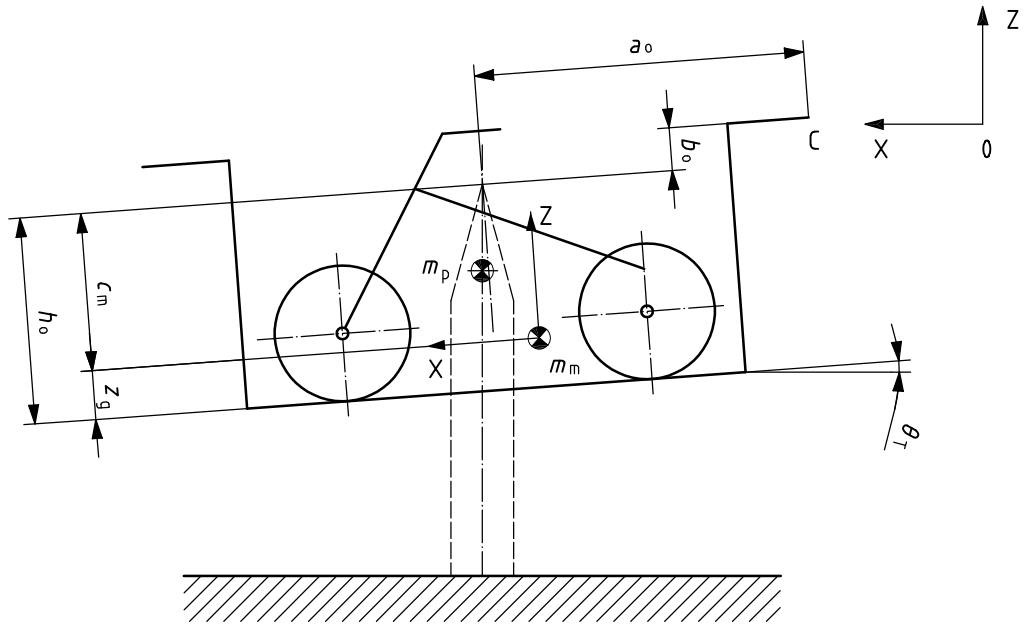

a) Measurement of θ_T

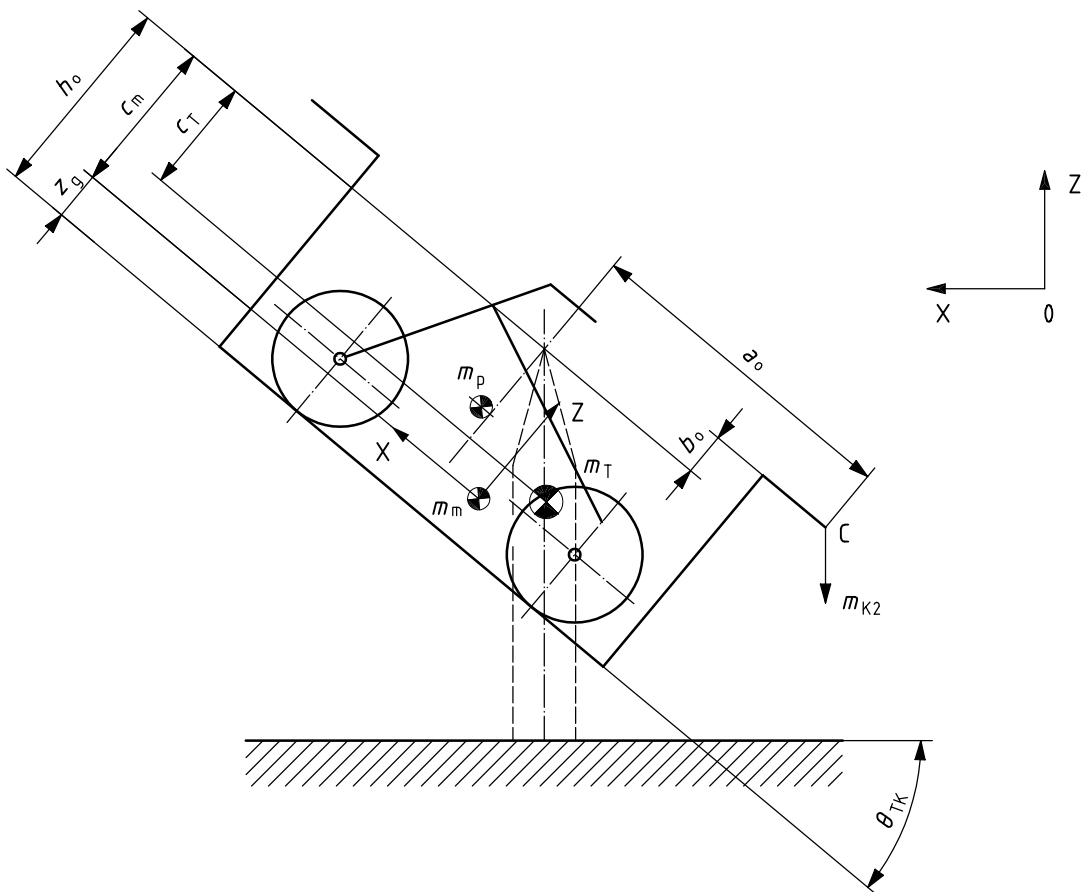

b) Measurement of θ_{TK}

Figure 8 — Location of centre of gravity of motorcycle along z -axis (point C side raised)

7 Test results

Record the measurement results in a test report in accordance with Annex A. Round the values of the centre of gravity to the nearest millimetre.

16

Annex A (normative)

Test report

The format shown in this annex shall be used to record the measurement results of centres of gravity for motorcycles, calculated in accordance with this International Standard.

Motorcycle — Centre of gravity — Measurement results to ISO 9130	
1 Vehicle identification	
1.1	Make, model, type:.....
1.2	Year model:.....
1.3	Vehicle Descriptor Section (VDS) (see ISO 3779):.....
1.4	Tyre pressure: front:..... kPa / rear:..... kPa
1.5	Suspension setting (if adjustable):.....
1.6	Suspension fixing position: front: ^a :..... rear ^b :.....
1.7	Other conditions ^c :.....
2 Test condition	
2.1	Date of test:.....
2.2	Place of test:.....
2.3	Measured by:.....
2.4	Rider: None / Dummy / Man ^d
2.5	Dummy reference (if applicable):.....
2.6	Seating position ^e :..... mm
2.7	Posture angle ^f :..... degrees
3 Test results	
3.1	Location of centre of gravity along the <i>x</i> -axis, x_g ^g :..... mm
3.2	Location of centre of gravity along the <i>y</i> -axis, y_g ^h :..... mm
3.3	Location of centre of gravity along the <i>z</i> -axis, z_g ⁱ :..... mm
<p>^a Distance from the centre of the head pipe to the ground. If this distance cannot be measured, record the reference point on the springing portion of the motorcycle front side and measure the distance from this point to the ground.</p> <p>^b Distance from the centre of the bolt mounting the upper side of the rear suspension to the ground. If this distance cannot be measured, record the reference point on the springing portion of the rear side of the motorcycle and measure the distance from this point to the ground.</p> <p>^c Of the conditions of Clause 4, record the added or changed measuring conditions.</p> <p>^d Cross out those that are not applicable.</p> <p>^e Distance from the front axle to the point H along the <i>x</i>-axis. The point H is the centre of rotation of the trunk of the body and femoral region of the rider.</p> <p>^f Angle formed by the line connecting the point S and H and the <i>x</i>-axis. Point S is the centre of rotation of the trunk of the body and arms of the rider.</p> <p>^g Distance from the front axle to the direction of the rear axle along the <i>x</i>-axis.</p> <p>^h Left side viewed in the direction from the vertical centre surface of the motorcycle in the progressing direction shall be positive.</p> <p>ⁱ Distance from the surface of the front and rear wheels touching the ground to upper side along the <i>z</i>-axis.</p>	

ICS 43.140

Price based on 17 pages