Paints and varnishes — Drying tests —

Part 1:

**Determination of through-dry state
and through-dry time**

Peintures et vernis — Essais de séchage —

*Partie 1: Détermination du séchage à cœur et du temps de séchage
à cœur*



PDF disclaimer

This PDF file may contain embedded typefaces. In accordance with Adobe's licensing policy, this file may be printed or viewed but shall not be edited unless the typefaces which are embedded are licensed to and installed on the computer performing the editing. In downloading this file, parties accept therein the responsibility of not infringing Adobe's licensing policy. The ISO Central Secretariat accepts no liability in this area.

Adobe is a trademark of Adobe Systems Incorporated.

Details of the software products used to create this PDF file can be found in the General Info relative to the file; the PDF-creation parameters were optimized for printing. Every care has been taken to ensure that the file is suitable for use by ISO member bodies. In the unlikely event that a problem relating to it is found, please inform the Central Secretariat at the address given below.



COPYRIGHT PROTECTED DOCUMENT

© ISO 2009

All rights reserved. Unless otherwise specified, no part of this publication may be reproduced or utilized in any form or by any means, electronic or mechanical, including photocopying and microfilm, without permission in writing from either ISO at the address below or ISO's member body in the country of the requester.

ISO copyright office
Case postale 56 • CH-1211 Geneva 20
Tel. + 41 22 749 01 11
Fax + 41 22 749 09 47
E-mail copyright@iso.org
Web www.iso.org

Published in Switzerland

Contents

Page

Foreword.....	iv
1 Scope	1
2 Normative references	1
3 Terms, definitions and abbreviated terms	1
4 Principle	2
5 Apparatus and materials	2
6 Sampling	4
7 Test panels	4
7.1 Substrate	4
7.2 Preparation and coating	4
8 Procedure	5
8.1 Preparation of apparatus	5
8.2 Drying the test panel	5
8.3 Determination of through-dry state	5
8.4 Determination of through-dry time	5
8.5 Thickness of coating	6
9 Precision	6
10 Test report	6
Bibliography	7

Foreword

ISO (the International Organization for Standardization) is a worldwide federation of national standards bodies (ISO member bodies). The work of preparing International Standards is normally carried out through ISO technical committees. Each member body interested in a subject for which a technical committee has been established has the right to be represented on that committee. International organizations, governmental and non-governmental, in liaison with ISO, also take part in the work. ISO collaborates closely with the International Electrotechnical Commission (IEC) on all matters of electrotechnical standardization.

International Standards are drafted in accordance with the rules given in the ISO/IEC Directives, Part 2.

The main task of technical committees is to prepare International Standards. Draft International Standards adopted by the technical committees are circulated to the member bodies for voting. Publication as an International Standard requires approval by at least 75 % of the member bodies casting a vote.

Attention is drawn to the possibility that some of the elements of this document may be the subject of patent rights. ISO shall not be held responsible for identifying any or all such patent rights.

ISO 9117-1 was prepared by Technical Committee ISO/TC 35, *Paints and varnishes*, Subcommittee SC 9, *General test methods for paints and varnishes*, in collaboration with CEN/TC 139, *Paints and varnishes*.

It cancels and replaces ISO 9117:1990, which has been technically revised. The main changes are:

- a) failure is defined in terms of damage, rather than damage or marking;
- b) the former Annex A concerning required supplementary information has been integrated in the test report.

ISO 9117 consists of the following parts, under the general title *Paints and varnishes — Drying tests*:

- *Part 1: Determination of through-dry state and through-dry time*
- *Part 2: Pressure test for stackability¹⁾*
- *Part 3: Surface-drying test using ballotini²⁾*

1) To be published. (Revision of ISO 4622:1992)

2) To be published. (Revision of ISO 1517:1973)

Paints and varnishes — Drying tests —

Part 1: Determination of through-dry state and through-dry time

1 Scope

This part of ISO 9117 specifies a test method for determining under standard conditions whether a single coat or a multi-coat system of paint, varnish or related material has reached the through-dry state after a specified drying period.

NOTE The test procedure may also be used to determine the time taken to achieve that state.

2 Normative references

The following referenced documents are indispensable for the application of this document. For dated references, only the edition cited applies. For undated references, the latest edition of the referenced document (including any amendments) applies.

ISO 48, *Rubber, vulcanized or thermoplastic — Determination of hardness (hardness between 10 IRHD and 100 IRHD)*

ISO 1513, *Paints and varnishes — Preparation of test samples*

ISO 1514, *Paints and varnishes — Standard panels for testing*

ISO 2808, *Paints and varnishes — Determination of film thickness*

ISO 15528, *Paints, varnishes and raw materials for paints and varnishes — Sampling*

3 Terms, definitions and abbreviated terms

For the purposes of this document, the following terms, definitions and abbreviated terms apply.

3.1

IRHD scale

international rubber hardness degree scale

3.2

through-dry state

condition of a film in which it is dry throughout its thickness

NOTE 1 The through-dry state should not be confused with the condition in which the surface of the film is dry but the bulk of the coating is still mobile.

NOTE 2 For the purposes of this part of ISO 9117, a single coating or a multi-coat system of paint or varnish or related material is considered to be through-dry when a specified gauze under specified pressure, torsion and time does not damage the film.

**3.3
through-dry time**

period of time between the application of a coat to a prepared test panel and the achievement of the through-dry state, as determined by the specified test procedure

4 Principle

A coat of paint or varnish of agreed thickness is applied to a substrate and is allowed to dry under specified conditions. The completeness of drying throughout the coat is determined by examination of the surface of the coat after the application of a load, applied over a given area of the surface, and subsequent rotation of the load-applying face through 90°.

5 Apparatus and materials

Ordinary laboratory apparatus and glassware together with the following:

5.1 Baseplate and plunger assembly (see Figure 1 and Figure 2), consisting essentially of a baseplate and a free-sliding plunger. The plunger head shall have a diameter of at least 25 mm. It shall be designed in such a way that the underside of the head can align itself with the upper surface of the test panel.

NOTE 1 If the mass of the plunger is not greater than 250 g, the apparatus described in ISO 4622 ^[1] is suitable for the test.

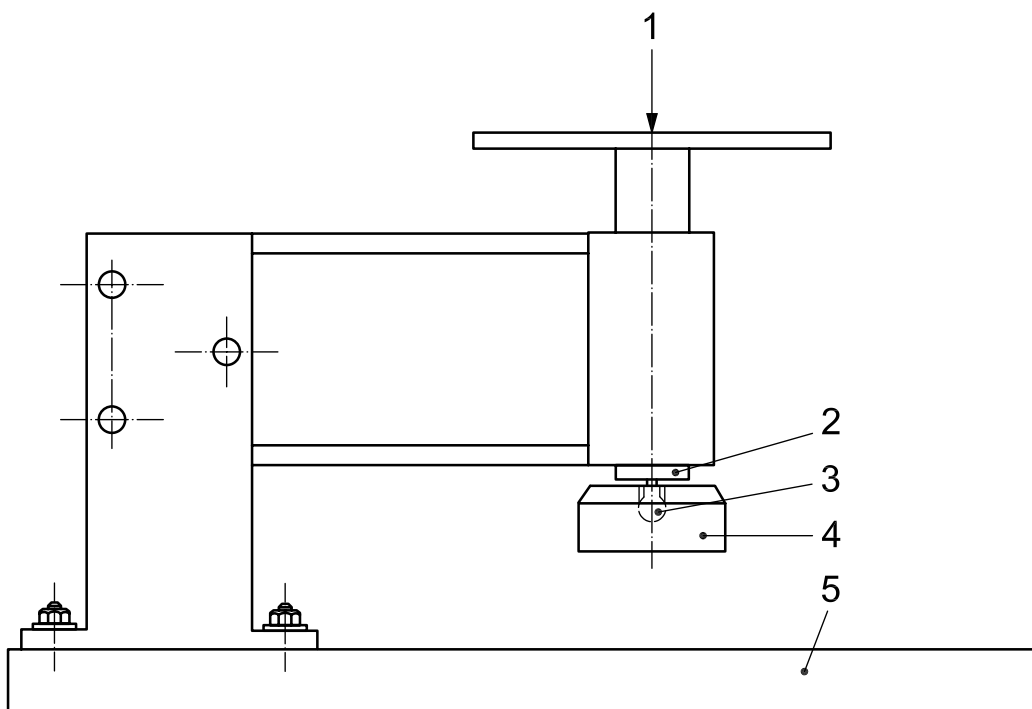
**Key**

- 1 weights
- 2 plunger
- 3 ball joint
- 4 plunger head
- 5 baseplate

Figure 1 — Baseplate and plunger assembly

A rubber disc (5.2) shall be attached to the centre of the underside of the plunger head using tape coated on both sides with adhesive. There shall be a device to firmly clamp a gauze (5.3) to the test face, and the plunger head shall be able to be rotated through 90°.

NOTE 2 It is recommended that a ball-joint connection be present between the plunger and its head and that, for reasons of economy, the plunger specified in ISO 4622 be used.

5.2 Flat rubber disc, of diameter (22 ± 1) mm, thickness $(5 \pm 0,5)$ mm and hardness (50 ± 5) IRHD (see ISO 48).

NOTE For reasons of economy, it is recommended that the rubber disc specified in ISO 3678^[2] be used.

5.3 Gauze, of woven monofilament polyamide, minimum size 100 mm × 100 mm. The gauze thread diameter shall be 0,120 mm and the gauze aperture approximately 0,2 mm.

5.4 Weights, giving a total mass of $(1\,500 \pm 10)$ g.

5.5 Stopwatch, accurate to 0,1 s.

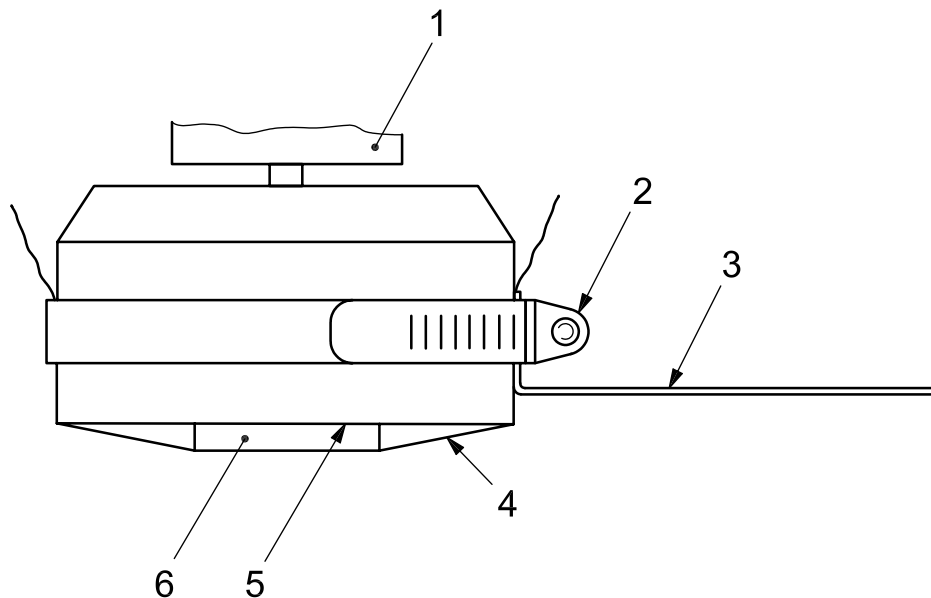

Key

- 1 plunger
- 2 clip
- 3 rod for rotating plunger head
- 4 gauze
- 5 double-faced adhesive tape
- 6 rubber disc

Figure 2 — Detail showing assembled plunger head

6 Sampling

Take a representative sample of the product to be tested (or of each product in the case of a multi-coat system), as described in ISO 15528.

Examine and prepare each sample for testing, as described in ISO 1513.

7 Test panels

7.1 Substrate

Select as the substrate three test panels (or six if both the through-dry state and the through-dry time are to be determined) of a type described in ISO 1514, where possible ensuring that the substrate is equivalent to the intended application.

7.2 Preparation and coating

Prepare the test panels (see 7.1) in accordance with ISO 1514 and then coat them with the product or system under test by the specified method to the thickness specified for the dry film.

The coating method and dry film thickness shall be as specified by the manufacturer, or agreed between interested parties, and included in the test report [see Clause 10, items c) 2) and c) 3)].

8 Procedure

8.1 Preparation of apparatus

Clamp the gauze (5.3) over the rubber disc (5.2) under the plunger head (see Figure 2), taking care to ensure that the exposed surface of the gauze is free from creases. Take a fresh piece of gauze for each test.

8.2 Drying the test panel

Dry (or stove) and age, if applicable, each coated test panel in a horizontal position with free circulation of air, but shielded from draughts and direct sunlight, for the specified time under the specified conditions.

The drying (or stoving) and aging time and conditions shall be as specified by the manufacturer, or agreed between the interested parties, and included in the test report [see Clause 10, items c) 4) and c) 5)].

8.3 Determination of through-dry state

8.3.1 On completion of the specified drying time (see 8.2), place a test panel on the baseplate.

8.3.2 Place the weights (5.4) on the top of the plunger. Gently lower the plunger so that the gauze is in contact with the test panel. Start the stopwatch (5.5) and allow the plunger to remain in this position for (10 ± 1) s.

8.3.3 At the end of this period, turn the plunger head through an angle of 90° over a period of about 2 s. Immediately raise the plunger, remove the test panel and examine the coat in the test area using the naked eye.

8.3.4 Repeat the procedure in 8.3.1 to 8.3.3 on two additional coated panels.

8.3.5 If no damage is observed on any of the three test surfaces, report the result as "through-dry state achieved". If damage is observed on one or more of the three test surfaces, report the result as "through-dry state not achieved".

Some coatings do not reach a point where they are totally unaffected by the test (i.e. a point where no mark, for instance, is left on the surface by the gauze), even when they have reached a functionally acceptable state of drying or cure. In such cases, the time when the coating reaches the stage at which the action carried out in the test does not cause deterioration of the coating to an extent where it could not perform its ultimate function shall be quoted.

For some coatings, e.g. those which are applied to protect the substrate rather than for cosmetic reasons, marking of the surface would not constitute an inability of the coating to perform its function. For highly pigmented coatings, the action of the gauze can cause polishing of the surface, leaving marks which might not be detrimental to the coating's ultimate function. In such cases, all observations shall be recorded in the test report.

Take care to avoid confusion between cohesive failure within the coat (a failure under this test) and failure of the coat to adhere to the substrate (not a failure under this test).

8.4 Determination of through-dry time

8.4.1 On completion of the specified drying time (see 8.2), place a test panel on the baseplate.

8.4.2 At appropriate intervals, carry out the test described in 8.3.2 and 8.3.3. Examine the coating in the test area for damage. Stop the test when no damage occurs to the coat (see 8.3.5).

8.4.3 Repeat the procedure in 8.4.1 and 8.4.2 on two additional coated panels.

8.4.4 Report the longest time taken in the three tests for the coat to reach the through-dry state.

8.5 Thickness of coating

Determine the thickness, in micrometres, of the coat in the through-dry state by one of the procedures specified in ISO 2808, using an untested area of the coated panel.

9 Precision

No precision data are currently available.

10 Test report

The test report shall contain at least the following information:

- a) all information necessary for identification of the product tested;
- b) a reference to this part of ISO 9117 (ISO 9117-1:2009);
- c) details of the preparation of the test panels, including:
 - 1) the substrate material and the surface preparation of the substrate (see 7.1 and 7.2),
 - 2) the method of application of the test coating to the substrate (see 7.2),
 - 3) the thickness, in micrometres, of the dry coating and the method of measurement from ISO 2808 (see 8.5), and whether it is a single coating or a multi-coat system,
 - 4) when assessing the through-dry state, the duration and conditions of drying (or stoving) the coat and the conditions of ageing, if applicable, before testing (see 8.3),
 - 5) when determining the through-dry time, the conditions of drying (or stoving) the coat and the conditions of ageing, if applicable, before testing, and the intervals between tests (see 8.4);
- d) the results of the test as specified in Clause 8, including:
 - 1) whether the coat achieved the through-dry state or not,
and/or
 - 2) the through-dry time,
 - 3) all observations (see 8.3.5, third paragraph);
- e) any deviations from the procedure specified;
- f) any unusual features (anomalies) observed during the test;
- g) the date of the test.

Bibliography

- [1] ISO 4622, *Paints and varnishes — Pressure test for stackability*³⁾
- [2] ISO 3678, *Paints and varnishes — Print-free test*

3) Under revision. The revision will be published as ISO 9117-2.

