**Textiles — Test methods for
nonwovens —**

Part 9:
**Determination of drapability including
drape coefficient**

Textiles — Méthodes d'essai pour nontissés —

Partie 9: Détermination du drapé et du coefficient de drapé



Reference number
ISO 9073-9:2008(E)

© ISO 2008

PDF disclaimer

This PDF file may contain embedded typefaces. In accordance with Adobe's licensing policy, this file may be printed or viewed but shall not be edited unless the typefaces which are embedded are licensed to and installed on the computer performing the editing. In downloading this file, parties accept therein the responsibility of not infringing Adobe's licensing policy. The ISO Central Secretariat accepts no liability in this area.

Adobe is a trademark of Adobe Systems Incorporated.

Details of the software products used to create this PDF file can be found in the General Info relative to the file; the PDF-creation parameters were optimized for printing. Every care has been taken to ensure that the file is suitable for use by ISO member bodies. In the unlikely event that a problem relating to it is found, please inform the Central Secretariat at the address given below.



COPYRIGHT PROTECTED DOCUMENT

© ISO 2008

All rights reserved. Unless otherwise specified, no part of this publication may be reproduced or utilized in any form or by any means, electronic or mechanical, including photocopying and microfilm, without permission in writing from either ISO at the address below or ISO's member body in the country of the requester.

ISO copyright office
Case postale 56 • CH-1211 Geneva 20
Tel. + 41 22 749 01 11
Fax + 41 22 749 09 47
E-mail copyright@iso.org
Web www.iso.org

Published in Switzerland

Contents

Page

Foreword.....	iv
Introduction	vi
1 Scope	1
2 Normative references	1
3 Terms and definitions.....	1
4 Principle	2
5 Apparatus	3
6 Sampling	4
7 Preparation and conditioning of test specimens	5
8 Preliminary procedures.....	5
9 Method A, using rings of paper.....	6
10 Method B, using image processing technology	7
11 Precision	12

Foreword

ISO (the International Organization for Standardization) is a worldwide federation of national standards bodies (ISO member bodies). The work of preparing International Standards is normally carried out through ISO technical committees. Each member body interested in a subject for which a technical committee has been established has the right to be represented on that committee. International organizations, governmental and non-governmental, in liaison with ISO, also take part in the work. ISO collaborates closely with the International Electrotechnical Commission (IEC) on all matters of electrotechnical standardization.

International Standards are drafted in accordance with the rules given in the ISO/IEC Directives, Part 2.

The main task of technical committees is to prepare International Standards. Draft International Standards adopted by the technical committees are circulated to the member bodies for voting. Publication as an International Standard requires approval by at least 75 % of the member bodies casting a vote.

Attention is drawn to the possibility that some of the elements of this document may be the subject of patent rights. ISO shall not be held responsible for identifying any or all such patent rights.

ISO 9073-9 was prepared by Technical Committee ISO/TC 38, *Textiles*.

This second edition cancels and replaces the first edition (ISO 9073-9:1995), which has been technically revised.

ISO 9073 consists of the following parts, under the general title *Textiles — Test methods for nonwovens*:

- *Part 1: Determination of mass per unit area*
- *Part 2: Determination of thickness*
- *Part 3: Determination of tensile strength and elongation*
- *Part 4: Determination of tear resistance*
- *Part 5: Resistance to mechanical penetration (ball burst procedure)¹⁾*
- *Part 6: Absorption*
- *Part 7: Determination of bending length*
- *Part 8: Determination of liquid strike-through time (simulated urine)*
- *Part 9: Determination of drapability including drape coefficient*
- *Part 10: Lint and other particles generation in the dry state*
- *Part 11: Run-off*
- *Part 12: Demand absorbency*
- *Part 13: Repeated liquid strike-through time*

1) To be published.

- *Part 14: Coverstock wetback*
- *Part 15: Determination of air permeability*
- *Part 16: Determination of resistance to penetration by water (hydrostatic pressure)*
- *Part 17: Determination of water penetration (spray impact)*
- *Part 18: Determination of breaking strength and elongation of nonwoven materials using the grab tensile test*

Introduction

This part of ISO 9073 is a revision of the current drape evaluation method, ISO 9073-9:1995, *Textiles — Test methods for nonwovens — Part 9: Determination of drape coefficient*. With a conventional method using rings of paper, some manual operations of an expert, such as contour marking, mark cutting, weighting and comparing of weights are necessary. With this new proposed method using image processing technology with a digital camera, various drapability parameters can be easily obtained through simple and automatic operations. For the determination of drape coefficient, both the conventional method and the automatic method are available. Additionally, using the automatic method, drape shape parameters and statistical information, including drape wave amplitude, wavelength and number of nodes, can be quantitatively obtained from a captured image. For automatic evaluation, some attachments to the conventional drape tester are needed and they include a frame and a stand for supporting the digital camera.

.....

Textiles — Test methods for nonwovens —

Part 9: Determination of drapability including drape coefficient

1 Scope

This part of ISO 9073 specifies a test method that is used to determine the drape coefficient of fabrics (nonwovens, wovens and knitted fabrics).

SI values are regarded as the official standard system of measurement for this standard test method.

2 Normative references

The following referenced documents are indispensable for the application of this document. For dated references, only the edition cited applies. For undated references, the latest edition of the referenced document (including any amendments) applies.

ISO 139:2005, *Textiles — Standard atmospheres for conditioning and testing*

ISO 186:2002, *Paper and board — Sampling to determine average quality*

3 Terms and definitions

For the purposes of this document, the following terms and definitions apply.

3.1

drapability

ability of a circular specimen of fabric of known size to deform when suspended under specified conditions

3.2

node number

one of the drape shape parameters expressed in the number of drape waves/folds

3.3

wave amplitude

one of the drape shape parameters indicating the size (in centimetres) of the most dominant drape waves/folds

3.4

wavelength

one of the drape shape parameters indicating the wavelength of the most dominant drape waves/folds expressed in degrees of a circle (0° to 360°)

3.5

minimum amplitude

one of the statistics indicating the smallest size of drape wave/folds present, expressed in centimetres

- 3.6**
maximum amplitude
one of the statistics indicating the largest size of drape wave/folds present, expressed in centimetres
- 3.7**
average amplitude
one of the statistics indicating the mean drape wave/folds present, expressed in centimetres
- 3.8**
variance
one of the statistics indicating the distribution of the drape wave/folds amplitude, expressed in centimetres
- 3.9**
Fourier transform/original and dominant/original
the three fitness factors to verify the fit of the Fourier transformation and to determine the dominant wave, expressed as percentages
- 3.10**
coefficient of drapability
drape coefficient
ratio between the area of the projected shadow of the draped specimen, expressed as a percentage, and the area of the undraped (flat) specimen

4 Principle

The circular specimen of the fabric being tested is held horizontally between smaller concentric discs, and the exterior ring of fabric is allowed to drape into folds around the lower supporting disc. Both of the following evaluation methods are available in this procedure and are listed as methods A and B.

Method A, using rings of paper

The shadow of the draped specimen is cast from below onto a ring of paper of known mass and of the same size as the unsupported part of the test specimen. The outline of the shadow is traced onto the ring of paper and the paper is then cut along the trace of the shadow. The drape coefficient is the mass of that part of the paper ring representing the shadow, expressed as a percentage of the mass of the whole paper ring.

Method B, using image processing technology

The shadow of the draped specimen is cast from below onto a white sheeting covering the top translucent lid and centre-plates. Detailed quantitative information on the drapability of the test specimen is obtained from digital images captured with a commercial digital camera (or a scanner) after cutting the paper around its shadow contour. The captured images, initially having grey levels, are transformed into monochrome images through noise filtering and thresholding. The two-dimensional monochrome images of draped shadows described above are firstly transformed into polar (θ, r) coordinates as shown in Figure 1, where the X-axis from 0° to 360° is the angle, in degrees, from the baseline passing through the centre of the circle, and r (Y-axis) is the amplitude, in centimetres. The shape parameters of a two-dimensional geometric drape model defined as the number of nodes (waves or folds), the positions of nodes, wavelength and amplitude data and various statistical information, can then be obtained using image processing technology and frequency analysis as well as the traditional drape coefficient. A three-dimensional drape shape can be regenerated from its captured two-dimensional drape images, with a three-dimensional simulator.

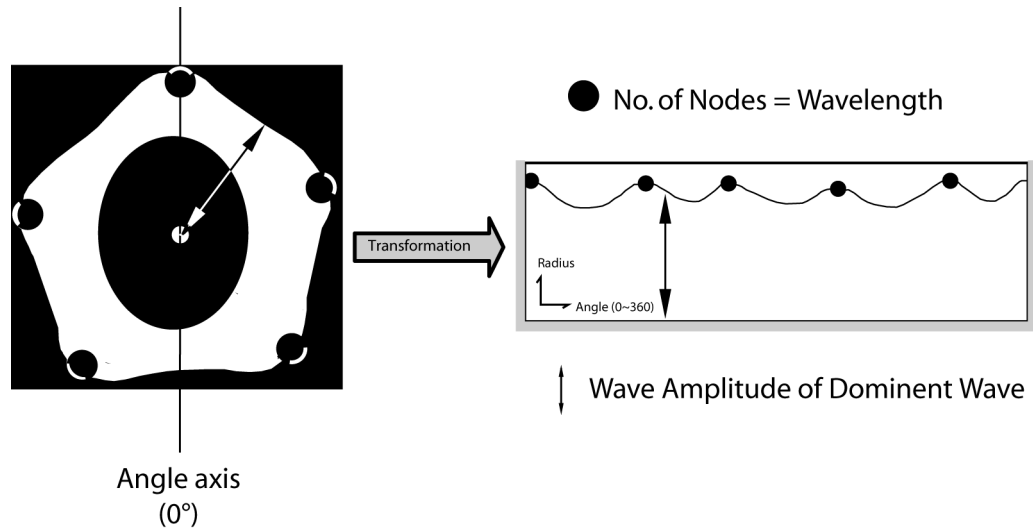

Figure 1 — Sample of the software printout

5 Apparatus

5.1 Apparatus for methods A and B

5.1.1 Drape meter.

This comprises

- a box-like apparatus with a translucent lid, see Figure 2,
- two horizontal discs, 18 cm in diameter, between which the test specimen is held, the lower disc having a central locating pin,
- a point source of light, positioned centrally beneath the discs and at the focus of a concave parabolic mirror which reflects parallel light vertically past the discs onto the lid of the instrument, and
- a centre-plate on the apparatus lid to locate the paper ring (or a white sheeting material with a high thread count).

5.1.2 Three circular templates, with diameters of 24 cm, 30 cm and 36 cm, respectively, adapted to facilitate marking the centre of the test specimen.

5.1.3 Stopwatch.

5.2 Supplementary apparatus for method A

5.2.1 Rings of translucent paper, with an internal diameter of 18 cm and an external diameter of 24 cm, 30 cm and 36 cm, respectively.

5.2.2 Balance, capable of determining the mass to an accuracy of 0,01 g.

5.3 Supplementary apparatus for method B

5.3.1 A frame cover and a support stand, used to attach the digital camera to the testing equipment. The stand is equipped with an 80 cm high support to hold the digital camera just above the centre of the cover plate on the test equipment.

5.3.2 Digital camera, supporting a direct (or USB) communication with the PC and capable of capturing images of test fabrics digitally.

5.3.3 Evaluation software, operated with Windows 98® or a more recent version. This software is capable of viewing the fabric shadow on the white sheet which is laid on the machine's top surface and then capturing and producing a three-dimensional image while transforming it into a monochrome image and automatically searching the contour of the image. This software calculates the Fourier transformation and determines the drape shape parameters while showing the various statistical results, and issues a final report.

5.3.4 White sheet material with a high thread count can be used as a covering for the centre-plate and translucent lid. This white material will catch the shadow of the specimen below. This material should be made from fibres that resist wrinkling and which lie flat on the surface.

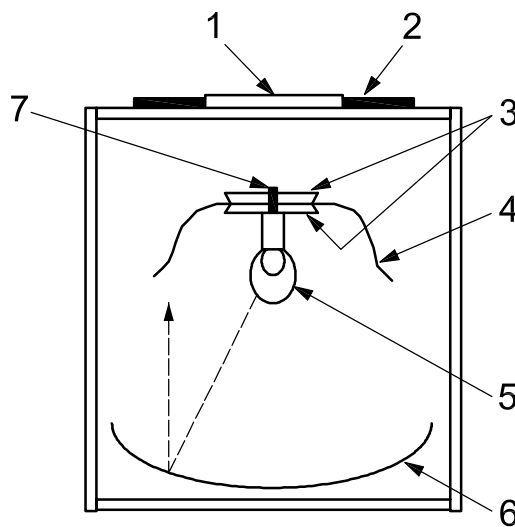

Key

- 1 lid centre-plate
- 2 paper ring
- 3 discs holding test piece
- 4 draped textile test piece
- 5 point source of light
- 6 parabolic mirror
- 7 locating pin

Figure 2 — Drape meter

6 Sampling

6.1 General

Carry out sampling of the test fabrics in accordance with ISO 186.

6.2 Selection of test specimen diameter

Perform a preliminary test (see Clause 8) using a test specimen of 30 cm in diameter, and calculate the drape coefficient (or drape ratio) for this diameter (D_{30}).

- a) If the drape coefficient is in the range of 30 % to 85 %, use test specimens of 30 cm diameter for all the tests.

- b) If the drape coefficient is outside the range of 30 % to 85 %, in addition to testing 30 cm diameter test specimens, carry out tests in accordance with c) or d) below, as appropriate:
- c) For limp fabrics of less than 30 %, use test specimens of 24 cm diameter, characterized by a drape coefficient of D_{30} .
- d) For stiff fabrics of greater than 85 %, use test specimens of 36 cm diameter, characterized by a drape coefficient of D_{30} .
- e) Place the test specimens on a flat horizontal surface and, using a template (5.1.2), trace the test specimens, mark the centre of each and cut them out. All specimens should be free from creases or folds because they will distort the test results.
- f) On each test specimen, mark both sides, (a) and (b).

Results obtained on test specimens of different diameter are not directly comparable, thus, in all cases, tests also need to be carried out on a 30 cm diameter test specimen, regardless of the drape coefficient.

7 Preparation and conditioning of test specimens

7.1 General

Condition the material to be tested for at least 24 h in one of the standard atmospheres specified in ISO 139.

7.2 Selection of test specimens

Take the test specimens, in accordance with 6.2, from areas of the sample that are free of folds, wrinkles and any distortions that would make these specimens abnormal compared with the rest of the test material.

Care in handling should be observed so that specimens do not contact any contaminants, such as soap, salt, oil, etc.

8 Preliminary procedures

8.1 Checking the apparatus

Check the drape-meter apparatus (5.1.1) as follows.

- a) Ensure that the centre-plate on the apparatus lid is horizontal. Adjustments can be made using a bubble level and the levelling feet on the base of the apparatus.
- b) Switch on the light to verify that the filament of the light source is focused at the parabolic mirror, by placing the 30 cm diameter template (5.1.2) centrally on the lower support disc of the apparatus. A centrally situated shadow of 30 cm diameter should be cast on a 36 cm diameter paper ring (5.2.1) or white sheeting (5.3.4), which is placed on the top surface of the box lid of the apparatus.

8.2 Preliminary evaluation

Carry out a preliminary evaluation as follows.

- a) Place one fabric test specimen, face (a) downward, on the lower horizontal disc of the test equipment.
- b) If the specimen drapes to form folds at regular intervals around its circumference, the measurement can be carried out.
- c) If the specimen has a predisposition to bend in line with two planes located on either side of the support disc, do not carry out the measurement but record this fact in the test report.

9 Method A, using rings of paper

9.1 Apparatus

See 5.1 and 5.2.

9.2 Procedure

Carry out the procedure as follows.

- a) Place a ring of paper (5.2.1), of the same outside diameter as the test specimen, on the apparatus lid.
- b) Place the test specimen on the lower horizontal disc of the apparatus (5.1.1) so that the locating pin passes through the centre of the test specimen. Then position the top disc on the test specimen with the pin fitting into the hole in the top disc.
- c) Lower the lid of the apparatus and start the stopwatch (5.1.3).
- d) After 30 s, switch on the light source and, without delay, draw around the periphery of the shadow cast on the paper ring.
- e) Remove the paper ring. Fold it so that it will fit on the balance and determine the mass, m_{pr} , of the paper ring to the nearest 0,01 g.
- f) Cut the paper ring around the periphery of the shadow which was traced on the paper. Discard the area of the paper ring which was not shaded, and determine the mass, m_{sa} , of the residual portion of the paper ring to the nearest 0,01 g (5.2.2).
- g) Repeat procedures 9.2 a) to 9.2 f) on the same fabric test specimen but with the other surface (b) uppermost, and using a fresh paper ring.
- h) Repeat the procedures twice more on each test specimen. Three specimens tested on both sides, for a total of six measurements on each test sample, is the minimum number of data points for each variable.

9.3 Calculations

Carry out the following calculations.

- a) For each test specimen diameter used, carry out separate calculations in accordance with 9.3 c) and 9.3 d).
- b) For each of the six readings on each test specimen, calculate the drape coefficient, D , expressed as a percentage, using the following equation:

$$D = \frac{m_{sa}}{m_{pr}} \times 100$$

where

m_{pr} is the initial mass (before cutting) of the paper ring, in grams;

m_{sa} is the mass of the part of the paper ring representing the shadow, in grams.

- c) Calculate the mean drape coefficient, expressed as a percentage, for surfaces (a) and (b), separately.
- d) Calculate the overall mean drape coefficient, expressed as a percentage.

9.4 Test report

In addition to the precise test results, the report shall include the following information:

- a) a reference to the test method in this part of ISO 9073, ISO 9073-9;
- b) complete identification of all materials tested and the method of sampling;
- c) name and address of the testing institution;
- d) make and model of the testing equipment;
- e) diameter of template used (i.e. 24 cm, 30 cm or 36 cm);
- f) laboratory testing conditions;
- g) number of specimens tested for each test sample;
- h) for computer processed data, the software used and the version;
- i) deviation from the standard test procedure, if any;
- j) when calculated, the standard deviation or the coefficient of variation;
- k) whether or not samples were conditioned prior to testing and, if so, for how long;
- l) anything unusual noted during the testing;
- m) test results for 30 cm diameter test specimens and, if appropriate, also for 24 cm or 36 cm diameter test specimens. Include the following information:
 - 1) individual drape coefficients for each side, (a) and (b), of each test specimen;
 - 2) mean drape coefficients for sides (a) and (b);
 - 3) overall mean drape coefficient for each test sample;
 - 4) number of folds present in each test specimen, and the overall mean for each sample.

10 Method B, using image processing technology

10.1 Apparatus

See 5.1 and 5.3 as well as Figures 3 and 4.

The Drape Meter User's Manual is essential for performing this test method. This manual is provided with the camera and the software interface from DM Technology Co. Ltd²⁾.

2) The Drape Meter is a product supplied by DM Technology Co. Ltd. This information is given for the convenience of users of this part of ISO 9073 and does not constitute an endorsement by ISO of this product. Equivalent products may be used if they can be shown to lead to the same results.

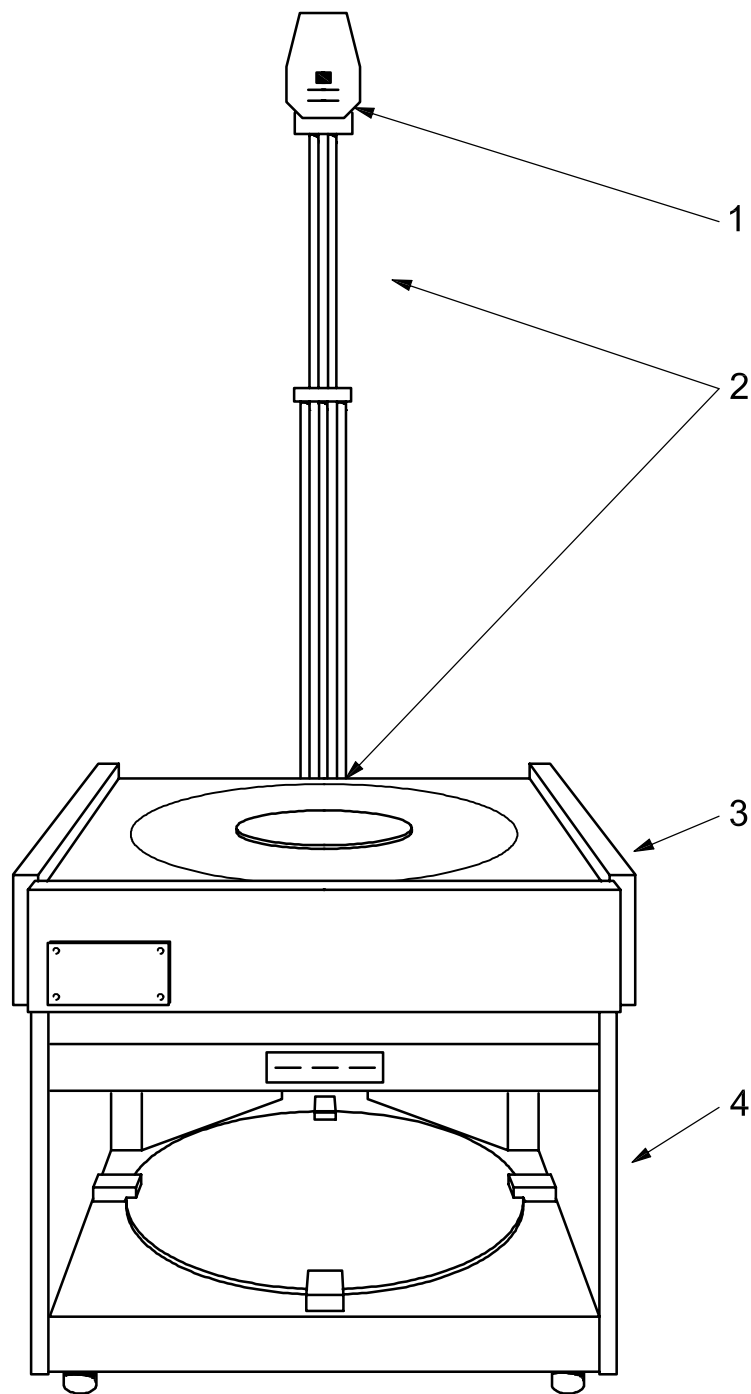

Key

- 1 camera
- 2 camera stand and collar
- 3 white sheet
- 4 standard apparatus

Figure 3 — Drape meter for the imaging process

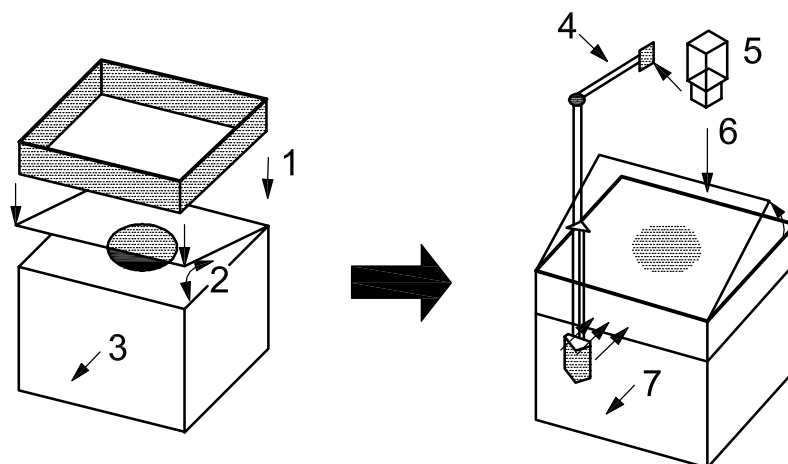

Key

- 1 stand frame
- 2 open/close
- 3 front
- 4 stand
- 5 camera
- 6 viewing axis
- 7 back

Figure 4 — Diagram of the equipment

NOTE This image processing technology eliminates the need for rings of translucent paper and for the operator to be marking, cutting, weighing and calculating.

10.2 Procedure

Carry out the procedure as follows.

- a) Cover the lid of the drape meter (5.1.1) completely with white sheeting.
- b) Place the prepared test specimen on the lower 18 cm supporting plate of the apparatus so that the locating pin passes through the centre of the test specimen. Then position the top 18 cm disc on the test specimen with the pin fitting into the hole in the top disc.
- c) Lower the lid of the apparatus and start the stopwatch (5.1.3).

NOTE Lowering the lid will remove the support from the test specimen. This will allow the specimen to drape, making the timing critical.

- d) After 30 s, switch on the light source. Care should be taken to centre the camera image (5.3.2) before the image is saved.
- e) Without delay, execute the evaluation software (5.3.3). Capture the digital shadow image which is present on the white sheeting (5.3.4) by clicking the camera icon.
- f) Input the parameter setting by selecting the diameter of the test specimen.
- g) Click "Image capture" and make camera adjustments on the "View Finder" screen. First, click the adjustments setting and set the settings as shown in the owner's manual.
- h) Click to save the captured image using the same "View Finder" screen.

- i) On the “Threshold Determination” screen
 - 1) Check [√] “Overlay” and move both slides all the way to the left or ∅.
 - 2) Move the slide marked “darker than” until the draped image is completely blue.
 - 3) Move the slide marked “brighter than” until the supporting plate becomes completely black.
 - 4) Turn off the Overlay.
 - 5) Click [OK].
- j) At the “processed image” screen, the noise can be edited.
- k) If the black and white image [after the calibration step 10.2 i)] is noisy (spots of white in the black or black spots in the white), use the tools on the left side of the screen to clear the image. Press the desired shape button (i.e. O, 0, □). Use the left side of the mouse to fill in space, and the right side of the mouse to erase space.
- l) To perform drape analysis, press the “3-D model” icon. This will bring out the fabric shape generator.
 - Press the left side of the mouse and drag to move the 3-D images.
 - Press the “texture” button and select the desired pattern to add pattern to the original image.
- m) Click the “results” button to bring up the “Measurement Result” screen. See Figure 5.
- n) The drape shape parameters and statistics are all calculated automatically.
- o) Print the test report.
- p) Repeat steps 10.2 b) to 10.2 o) on the same test specimen but turn the specimen over and test the other surface.
- q) Repeat the procedures twice more on each test specimen. Three specimens tested on both sides, for a total of six measurements on each test sample, is the minimum number of data points for each variable.

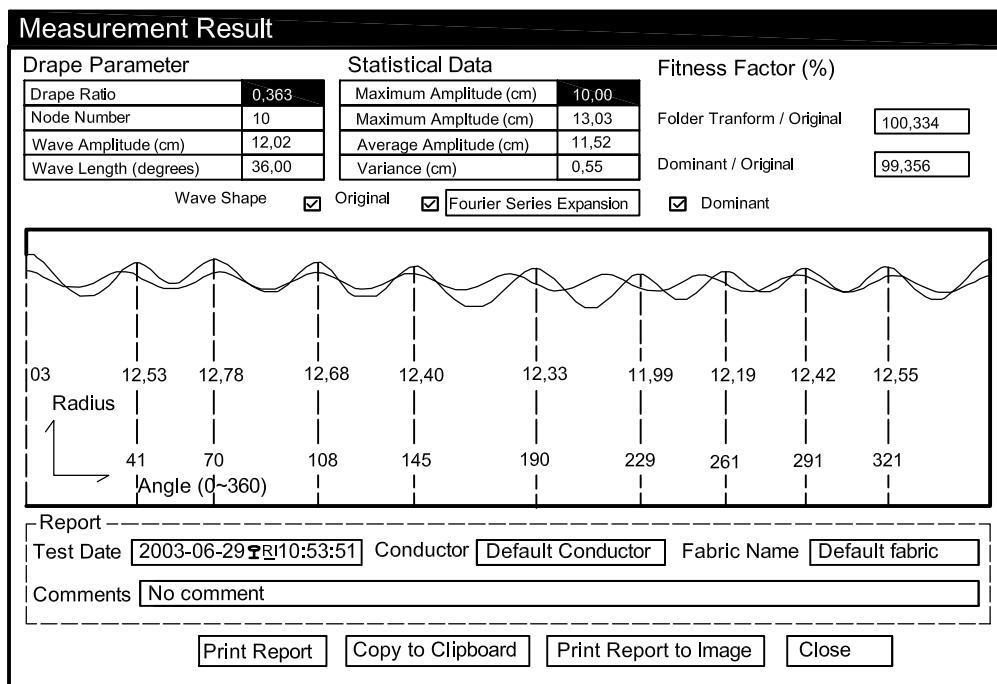

Figure 5 — Example

10.3 Calculations

10.3.1 For each test specimen diameter used, carry out separate calculations.

10.3.2 For each of the six readings on each test specimen, calculate the following, which is automatically obtained from the evaluation software (5.3.3) (see example in Figure 5).

a) Drape coefficient, D , expressed as a percentage, using the following equation:

$$D = \frac{A_s - A_d}{A_o - A_d} \times 100$$

where A_o , A_d and A_s are the original area of an undraped specimen, the area of a supporting plate, and the projected shadow area of the specimen after draping, respectively.

- b) Node number, one of the drape shape parameters, expressed as the number of drape waves/folds.
- c) Wave amplitude, one of the drape shape parameters, indicating the size, in centimetres, of the most dominant drape waves/folds.
- d) Wavelength, one of the drape shape parameters, indicating the wavelength of the most dominant drape waves/folds, expressed in degrees of a circle (0° to 360°).
- e) Minimum amplitude, one of the statistics indicating the smallest size of drape waves/folds, expressed in centimetres.
- f) Maximum amplitude, one of the statistics indicating the largest size of drape waves/folds present, expressed in centimetres.
- g) Average amplitude, one of the statistics indicating the mean drape waves/folds present, expressed in centimetres.
- h) Variance, one of the statistics indicating the distribution of the drape waves/folds amplitude, expressed in centimetres.
- i) Fourier transform/original and dominant/original, the three fitness factors to verify the fit of the Fourier transformation and to determine the dominant wave, expressed in percentages, using the following equation:

$$\text{Fourier transform/original} = \frac{B_f}{B_o} \times 100$$

$$\text{Dominant/original} = \frac{B_d}{B_o} \times 100$$

where B_o , B_f and B_d are the areas of the original captured draped image, its Fourier transformed shape, and the ideal shape recomposed from a determined dominant wave, respectively, as shown in Figure 5.

- j) Graph, in polar coordinates, where the X-axis (from 0° to 360°) is the wavelength, in degrees, from the baseline passing through the centre of the centre-plate (5.1.1) and r (Y-axis) is the amplitude, in centimetres, representing each value of the wave amplitude and the wavelength at each node.

10.3.3 Calculate the mean drape coefficient, drape shape parameters, statistics and fitness factors for face (a) and for face (b).

10.3.4 Calculate the overall mean drape coefficient, drape shape parameters, statistics and fitness factors.

10.4 Test report

In addition to the precise test results, the report shall include the following information:

- a) a reference to the test method in this part of ISO 9073, ISO 9073-9;
- b) complete identification of all materials tested and method of sampling;
- c) name and address of testing institution;
- d) make and model of testing equipment;
- e) laboratory testing conditions;
- f) for computer processed data, the software used and the version;
- g) deviation from the standard test procedure, if any;
- h) when calculated, the standard deviation or the coefficient of variation;
- i) whether or not samples were conditioned prior to testing and, if so, for how long;
- j) anything unusual noted during the testing;
- k) diameter of template (i.e. 30 cm and, if appropriate, 24 cm or 36 cm);
- l) whether or not the test specimens drape under the test conditions specified in 8.2;
- m) test results (see 10.3.2) for 30 cm diameter test specimens and, if appropriate, also for 24 cm or 36 cm diameter test specimens, as follows:
 - 1) individual drape coefficients, drape shape parameters, statistics and fitness factors for each face of each test specimen;
 - 2) mean drape coefficients, drape shape parameters, statistics and fitness factors for face (a) and for face (b);
 - 3) overall mean drape coefficient, drape shape parameters, statistics and fitness factors.

11 Precision

The precision for this method is yet to be determined.

.....

ICS 59.080.30

Price based on 12 pages