

---

---

**Textiles — Test methods  
for nonwovens —**

**Part 14:  
Coverstock wetback**

*Textiles — Méthodes d'essai pour nontissés —  
Partie 14: Remouillage de l'enveloppe*



Reference number  
ISO 9073-14:2006(E)

© ISO 2006

**PDF disclaimer**

This PDF file may contain embedded typefaces. In accordance with Adobe's licensing policy, this file may be printed or viewed but shall not be edited unless the typefaces which are embedded are licensed to and installed on the computer performing the editing. In downloading this file, parties accept therein the responsibility of not infringing Adobe's licensing policy. The ISO Central Secretariat accepts no liability in this area.

Adobe is a trademark of Adobe Systems Incorporated.

Details of the software products used to create this PDF file can be found in the General Info relative to the file; the PDF-creation parameters were optimized for printing. Every care has been taken to ensure that the file is suitable for use by ISO member bodies. In the unlikely event that a problem relating to it is found, please inform the Central Secretariat at the address given below.

© ISO 2006

All rights reserved. Unless otherwise specified, no part of this publication may be reproduced or utilized in any form or by any means, electronic or mechanical, including photocopying and microfilm, without permission in writing from either ISO at the address below or ISO's member body in the country of the requester.

ISO copyright office  
Case postale 56 • CH-1211 Geneva 20  
Tel. + 41 22 749 01 11  
Fax + 41 22 749 09 47  
E-mail [copyright@iso.org](mailto:copyright@iso.org)  
Web [www.iso.org](http://www.iso.org)

Published in Switzerland

# Contents

Page

<b>Foreword</b> .....	<b>iv</b>
<b>1 Scope</b> .....	<b>1</b>
<b>2 Normative references</b> .....	<b>1</b>
<b>3 Principle</b> .....	<b>1</b>
<b>4 Material and reagents</b> .....	<b>2</b>
<b>5 Apparatus</b> .....	<b>2</b>
<b>6 Procedure</b> .....	<b>3</b>
<b>7 Test report</b> .....	<b>5</b>
<b>8 Useful additional information</b> .....	<b>5</b>
<b>Annex A (informative) Precision</b> .....	<b>8</b>
<b>Bibliography</b> .....	<b>9</b>

## Foreword

ISO (the International Organization for Standardization) is a worldwide federation of national standards bodies (ISO member bodies). The work of preparing International Standards is normally carried out through ISO technical committees. Each member body interested in a subject for which a technical committee has been established has the right to be represented on that committee. International organizations, governmental and non-governmental, in liaison with ISO, also take part in the work. ISO collaborates closely with the International Electrotechnical Commission (IEC) on all matters of electrotechnical standardization.

International Standards are drafted in accordance with the rules given in the ISO/IEC Directives, Part 2.

The main task of technical committees is to prepare International Standards. Draft International Standards adopted by the technical committees are circulated to the member bodies for voting. Publication as an International Standard requires approval by at least 75 % of the member bodies casting a vote.

Attention is drawn to the possibility that some of the elements of this document may be the subject of patent rights. ISO shall not be held responsible for identifying any or all such patent rights.

ISO 9073-14 was prepared by Technical Committee ISO/TC 38, *Textiles*.

ISO 9073 consists of the following parts, under the general title *Textiles — Test methods for nonwovens*:

- *Part 1: Determination of mass per unit area*
- *Part 2: Determination of thickness*
- *Part 3: Determination of tensile strength and elongation*
- *Part 4: Determination of tear resistance*
- *Part 6: Absorption*
- *Part 7: Determination of bending length*
- *Part 8: Determination of liquid strike-through time (simulated urine)*
- *Part 9: Evaluation of drapability including drape coefficient*
- *Part 10: Lint and other particles generation in the dry state*
- *Part 11: Run-off*
- *Part 12: Demand absorbency*
- *Part 13: Repeated liquid strike-through time*
- *Part 14: Coverstock wetback*

The following parts are under preparation:

- *Part 15: Evaluation of air permeability*
- *Part 16: Evaluation of water resistance (hydrostatic pressure test)*

- *Part 17: Evaluation of water penetration (spray impact) test*
- *Part 18: Determination of breaking strength and elongation of nonwoven materials using the grab tensile test*



# Textiles — Test methods for nonwovens —

## Part 14: Coverstock wetback

### 1 Scope

This part of ISO 9073 specifies a test method to examine the ability of diaper coverstock to resist the transport back onto the skin of a liquid which has already penetrated the coverstock.

This test corresponds with the repeated liquid strike-through time described in ISO 9073-13.

This test method is intended for quality control and is designed for comparison of wetback for different nonwoven coverstocks and treatments. It does not simulate in-use conditions for finished products.

### 2 Normative references

The following referenced documents are indispensable for the application of this document. For dated references, only the edition cited applies. For undated references, the latest edition of the referenced document (including any amendments) applies.

ISO 186, *Paper and board — Sampling to determine average quality*

ISO 5636-1, *Paper and board — Determination of air permeance (medium range) — Part 1: General method*

ISO 9073-6, *Textiles — Test methods for nonwovens — Part 6: Absorption*

ISO 9073-13, *Textiles — Test methods for nonwovens — Part 13: Repeated liquid strike-through time*

### 3 Principle

A piece of coverstock is placed over a standard absorbent medium (10 plies of filter paper) which is then loaded three times according to the repeated STT method proposed in ISO 9073-13 with a specific quantity of simulated urine. After the third dose, a simulated baby weight (SBW) is placed onto the coverstock and absorbent medium to ensure even spreading of the liquid.

A pre-weighed pick up paper is then placed on the coverstock and the simulated baby weight (SBW) is again put on top.

The mass of liquid absorbed by the pick up paper is defined as wetback.

## 4 Material and reagents

**4.1 Absorbent pad**, consisting of ten plies of filter paper (size 100 mm × 100 mm) with the test side upwards, as specified by the supplier.

The mean strike-through time, in 10 replicate determinations without the nonwoven, shall be within  $(1,7 \pm 0,3)$  s.

The liquid absorption capacity of paper, as determined by ISO 9073-6, shall be 480 % minimum.

**4.2 Simulated urine**, consisting of a 9 g/l solution of sodium chloride in deionized water with a surface tension of  $(70 \pm 2)$  mN/m at  $(23 \pm 2)$  °C.

This surface tension should be checked before each series of tests, as surface tension may change during storage.

**4.3 Pick-up paper**, 125 mm × 125 mm square.

Paper characteristics:

- the mass per unit area of paper shall be  $(90 \pm 4)$  g/m<sup>2</sup>; and
- the air flow resistance, as determined by ISO 5636-1, shall be  $(1,9 \pm 0,3)$  kPa.

## 5 Apparatus

**5.1 Burette**, of 50 ml capacity, with a supporting stand, or 5 ml pipette.

**5.2 Funnel**, fitted with a magnetic valve, giving a rate of discharge of 25 ml in  $(3,5 \pm 0,25)$  s.

**5.3 Ring stand** to support the funnel.

**5.4 Strike-through plate** (see Figures 2 and 3) constructed of 25 mm thick transparent acrylic sheet, of total mass  $(500 \pm 5)$  g, fitted with corrosion-resistant electrodes consisting of 1,6 mm diameter platinum or stainless steel wire set in grooves of cross-section 4,0 mm × 7,0 mm cut in the base of the plate and fixed with quick-setting epoxy resin.

The electrodes shall be positioned as shown in Figures 2 and 3.

The plate surface, electrode surface and the star-shaped orifice shall be clean and free from deposit or particulate matter. Clean regularly, e.g. with mildly abrasive car polish and dry cloth, and/or hot water.

**5.5 Base plate**, of transparent acrylic sheet, approximately 125 mm × 125 mm square and 5 mm thick.

**5.6 Electronic timer** measuring to the nearest 0,01 s.

**5.7 Simulated baby weight (SBW)**, consisting of:

- a weight, stainless steel base 10 cm × 10 cm including a handle, of total mass  $(4\ 000 \pm 20)$  g;
- a polyurethane (PU) foam rubber, 10 cm × 10 cm × 2 cm height (as described in 8.4);
- a polyethylene (PE) film, 25 µm thick.

Wrap the PE film around the foam, secure the film in place with tape then tape the film and foam to the weight (see Figure 1).



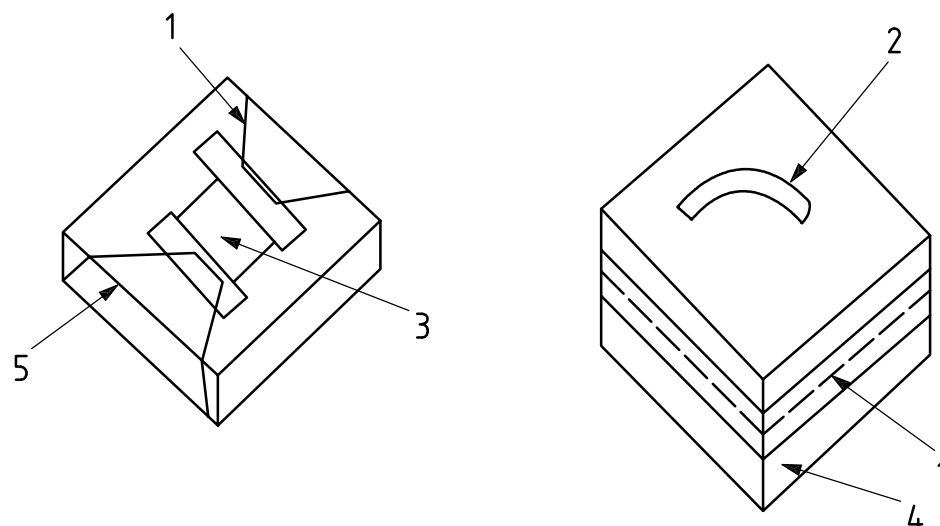

### Key

- 1 tape
- 2 4 kg weight
- 3 PU foam
- 4 foam plus PE film
- 5 film

Figure 1 — Simulated baby weight

## 6 Procedure

This test is conducted in conjunction with the repeated strike-through test (see ISO 9073-13) as follows:

- 6.1 Set up the ring stand holding the funnel. Make sure that the timer and conductivity detector are switched on, and electrodes are connected.
- 6.2 Cut the nonwoven test pieces, 125 mm × 125 mm, selected in accordance with ISO 186, if applicable.
- 6.3 Prepare one set of 10 plies of filter paper, stacking the paper plies on top of each other, test side upwards.
- 6.4 Weigh the set of 10 plies of filter paper and place them with the test side upwards on the strike-through baseplate. The mass ( $m$ ) of the filter paper will be used as a parameter to determine the total quantity of liquid ( $Q$ ) required for the wetback test.

The quantity of liquid ( $Q$ ) will be calculated by multiplying  $m$  by the loading factor (LF) of the filter paper (see 8.1).

The recommended loading factor is 3,30.

- 6.5 Place the nonwoven test piece on top of the set of 10 plies of filter paper. Position the nonwoven such that the direction of liquid flow during the test corresponds with the intended use of the nonwoven.

For example, for personal hygiene products, the side of the nonwoven that is intended to be in contact with the user's skin shall be facing upwards.

- 6.6 Place the strike-through plate on the top of the nonwoven with the centre of the plate approximately over the centre of the test piece. Centre the funnel over the orifice in the plate.

**6.7** Adjust the height of the funnel such that the dispensing tip is  $(45 \pm 1)$  mm above the top of the instrument baseplate. For Lister equipment <sup>1)</sup>, this corresponds to the minimum position of the head, as defined by the vertical positioning ring.

**6.8** Check whether the timer display shows zero. If not, reset.

**6.9** Dispense with the pipette or burette 5,0 ml of test liquid into the funnel, while keeping the discharge valve of the funnel closed.

**6.10** Open the magnetic discharge valve of the funnel to discharge the 5,0 ml of liquid. The initial flow of liquid will complete the circuit and start the electronic timer.

The timer will stop when the liquid has penetrated into the nonwoven and dropped below the level of the electrodes in the strike-through plate. At that time, start the stopwatch.

**6.11** Record the time indicated by the electronic timer (STT-1).

**6.12** Use the stopwatch to record a time interval of 60 s. During this period, dispense a fresh aliquot of 5,0 ml of test liquid into the funnel.

**6.13** As the stopwatch reads 60 s, repeat steps 6.10 to 6.12 for measuring the STT of the second dose (STT-2).

**6.14** As the stopwatch reads 60 s, repeat steps 6.10 and 6.11 for measuring the STT of the third dose (STT-3).

**6.15** Add an additional quantity of test liquid ( $Q_{\text{add}}$ ) in order to reach the specified quantity ( $Q$ ):

$$Q_{\text{add}} = Q - 15 \quad (\text{expressed in millilitres})$$

**6.16** Remove the baseplate with the sample and filter paper from the strike-through apparatus.

**6.17** Gently put the 4 kg weight assembly (5.7) onto the sample.

**6.18** The weight (5.7) remains in place for 3 min to ensure even diffusion of the liquid.

**6.19** Remove the weight (5.7) without disturbing the nonwoven test piece.

**6.20** Weigh two layers of pick-up paper to an accuracy of 0,001 g, record the mass ( $m_1$ ) and place them on the test piece.

**6.21** Remove residual liquid by wiping the contact surface of the weight (5.7) with a dry tissue, before gently replacing it over the pick up paper.

A loading speed should be applied in such a way that the last 5 cm displacement takes  $(5 \pm 1)$  s (see 8.3).

**6.22** The weight remains in place for  $2 \text{ min} \pm 2 \text{ s}$ , during which time wetback has occurred.

**6.23** Remove the weight and reweigh the pick-up paper ( $m_2$ ) to an accuracy of 0,001 g.

**6.24** Calculate the wetback value:  $m_{\text{WB}} = m_2 - m_1$  (expressed in grams).

**6.25** Repeat for the required number of test pieces. A minimum of three tests on test pieces from each sample is recommended.

**NOTE** If STT-3 is higher than 20 s, indicating non durable treatment of the nonwoven, repeat the test with one dose only. After STT-1 (6.11), add an additional quantity of test liquid [ $Q_{\text{add}} \text{ (ml)} = Q \text{ (ml)} - 5 \text{ ml}$ ] and measure the wetback according to 6.16 to 6.24.

---

1) Lister is an example of a suitable product(s) available commercially. This information is given for the convenience of users of this part of ISO 9073 and does not constitute an endorsement by ISO of this product.

## 7 Test report

The test report shall include the following information:

- a) complete identification of the nonwoven material;
- b) surface tension of simulated urine, if different from the value specified in 4.2;
- c) testing conditions;
- d) individual strike-through times, in seconds to an accuracy of 0,1 s;
- e) individual wetback (expressed in grams) to an accuracy of 0,01 g;
- f) calculate average and standard deviation of wetback (expressed in grams);
- g) any deviation from the procedure described in this part of ISO 9073.

## 8 Useful additional information

**8.1** The loading factor (LF) is dependent on the liquid absorbency capacity (LAC) and will change as the LAC changes.

A loading factor of 3,30 was found to be appropriate when using paper filters of a LAC of  $(480 \pm 30) \%$ .

A knowledge of the wetback versus loading factor curve for a coverstock is useful sometimes, as close to the break point, wetback dispersion increases dramatically.

The use of control nonwoven samples is strongly recommended to monitor the correct functioning of the test. Good wetback samples, one with wetback 0,12 g or less and the other around 0,20 g, are sufficient to monitor the test.

If the LAC of the filter paper used differs from  $(480 \pm 30) \%$  or if a refined procedure is needed for research or for ranking purpose, different loading factors can be used. Modified LAC and LF should be mentioned in the report.

**NOTE** If the LAC differs from the specifications, the filter paper supplier will indicate the recommended LF corresponding to this different LAC.

It is recommended that the same filter paper batches are used for wetback comparison purpose.

**8.2** The application of the weight in 6.17 and 6.21 is a critical step. The training of the operator can be provided by practising the placement of the weight on a balance without overcharging the balance by more than a few grams (5 g). Alternately an automatic system with a pneumatic piston can be used to apply the weight assembly consistently.

**8.3** The repeatability of this test depends on the maintenance of the strike-through plate in order to avoid the formation of sodium chloride crystals, the creation of a water film or any other contamination on the walls that could modify the strike-through time measurement, see the maintenance instructions from the plate manufacturer.

**8.4** The polyurethane foam specifications should be:

- density: 25 kg/m<sup>3</sup> to 75 kg/m<sup>3</sup> (see ISO 845);
- hardness: 150 N to 250 N for 40 % compression and 5 cm sample (see ASTM D 3574-86, Test B1).

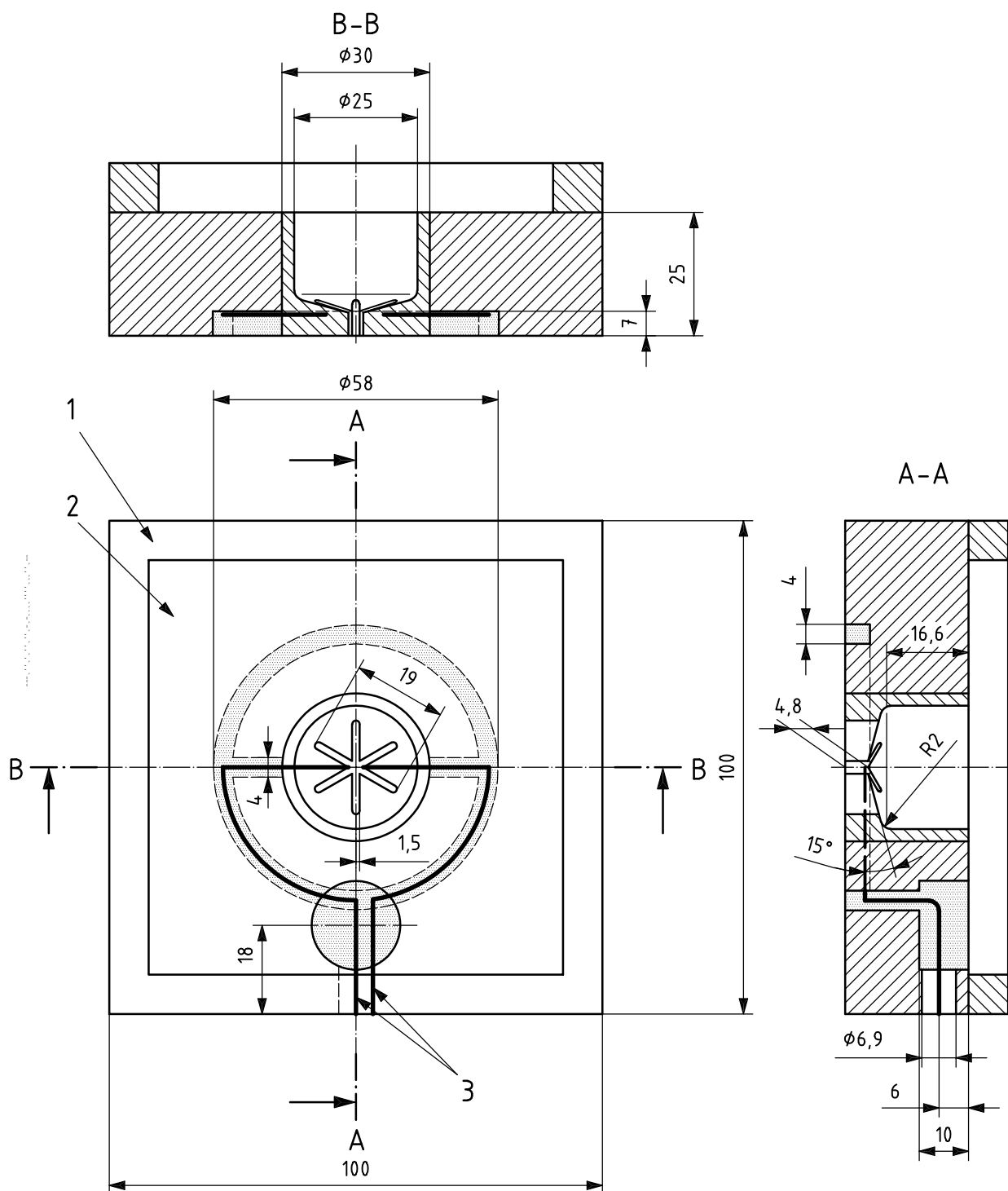

**Key**

- 1 optional weighing strips
- 2 strike-through plate (transparent acrylic sheet)
- 3 electrodes (1,6 mm in diameter), see 5.4

**Figure 2 — Liquid strike-through plate**

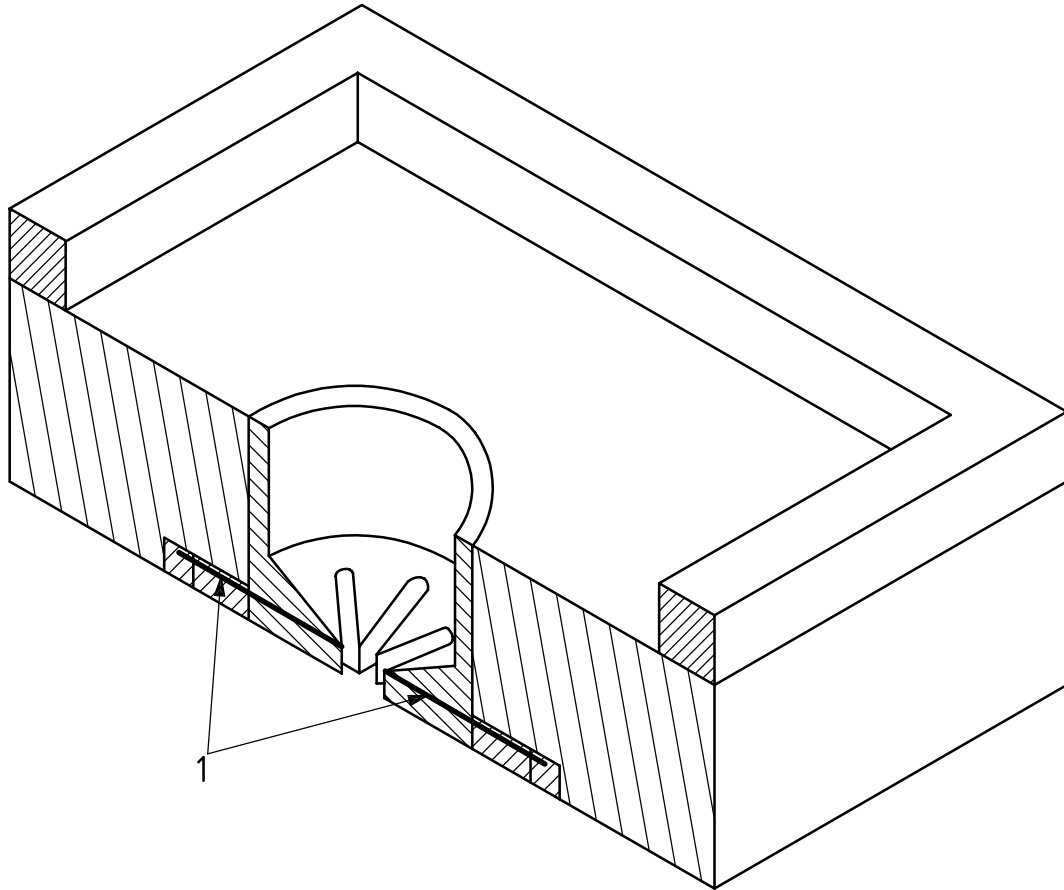

**Key**

- 1 wire electrodes (1,6 mm in diameter)

**Figure 3 — Section across strike-through plate on centreline of 25 mm diameter cavity**

## Annex A (informative)

### Precision

Figures for the repeatability and reproducibility of this method are the results of collaborative studies carried out in 2000 by EDANA <sup>2)</sup>, with the following data.

	SAMPLE A <sup>a</sup>	SAMPLE B <sup>b</sup>	SAMPLE C <sup>c</sup>
Number of participating laboratories	6	6	6
Number of non-eliminated laboratories	6	6	6
Number of single values of the non-eliminated laboratories	60	60	60
Wetback measuring after	STT-1	STT-3	STT-3
Average $m_{WB}$ (in grams)	0,13	0,13	0,17
Standard deviation of repeatability, $s_r$	0,01	0,03	0,05
Coefficient of repeatability, $CV_r$	9,8 %	23,2 %	28,5 %
Repeatability limit, $r$ ( $2,8 \times s_r$ )	0,04	0,09	0,14
Standard deviation of reproducibility, $s_R$	0,02	0,04	0,06
Coefficient of reproducibility, $CV_R$	17,5 %	30,2 %	34,3 %
Reproducibility limit, $R$ ( $2,8 \times s_R$ )	0,06	0,11	0,17
<sup>a</sup> Sample A: non-durable hydrophilic carded nonwoven. <sup>b</sup> Sample B: durable hydrophilic carded nonwoven. <sup>c</sup> Sample C: durable hydrophilic spunlaid nonwoven.			

2) EDANA: European Disposables and Nonwovens Association.

## Bibliography

- [1] ISO 845, *Cellular plastics and rubbers — Determination of apparent density*
- [2] ISO 5725-2, *Accuracy (trueness and precision) of measurement methods and results — Part 2: Basic method for the determination of repeatability and reproducibility of a standard measurement method*
- [3] ISO 9073-8, *Textiles — Test methods for nonwovens — Part 8: Determination of liquid strike-through time (simulated urine)*
- [4] ASTM D 3574-86, Test B1, *Standard Methods of Testing Flexible Cellular Materials — Slab, Bonded, and Molded Urethane Foams*

© ISO 2006. All rights reserved.

---

---

**ICS 59.080.30**

Price based on 9 pages