

INTERNATIONAL STANDARD

ISO
9022-2

Second edition
2002-10-15

Optics and optical instruments — Environmental test methods —

Part 2: Cold, heat and humidity

*Optique et instruments d'optique — Méthodes d'essais d'environnement —
Partie 2: Froid, chaleur et humidité*

Reference number
ISO 9022-2:2002(E)

© ISO 2002

PDF disclaimer

This PDF file may contain embedded typefaces. In accordance with Adobe's licensing policy, this file may be printed or viewed but shall not be edited unless the typefaces which are embedded are licensed to and installed on the computer performing the editing. In downloading this file, parties accept therein the responsibility of not infringing Adobe's licensing policy. The ISO Central Secretariat accepts no liability in this area.

Adobe is a trademark of Adobe Systems Incorporated.

Details of the software products used to create this PDF file can be found in the General Info relative to the file; the PDF-creation parameters were optimized for printing. Every care has been taken to ensure that the file is suitable for use by ISO member bodies. In the unlikely event that a problem relating to it is found, please inform the Central Secretariat at the address given below.

© ISO 2002

All rights reserved. Unless otherwise specified, no part of this publication may be reproduced or utilized in any form or by any means, electronic or mechanical, including photocopying and microfilm, without permission in writing from either ISO at the address below or ISO's member body in the country of the requester.

ISO copyright office
Case postale 56 • CH-1211 Geneva 20
Tel. + 41 22 749 01 11
Fax + 41 22 749 09 47
E-mail copyright@iso.ch
Web www.iso.ch

Printed in Switzerland

Foreword

ISO (the International Organization for Standardization) is a worldwide federation of national standards bodies (ISO member bodies). The work of preparing International Standards is normally carried out through ISO technical committees. Each member body interested in a subject for which a technical committee has been established has the right to be represented on that committee. International organizations, governmental and non-governmental, in liaison with ISO, also take part in the work. ISO collaborates closely with the International Electrotechnical Commission (IEC) on all matters of electrotechnical standardization.

International Standards are drafted in accordance with the rules given in the ISO/IEC Directives, Part 3.

Draft International Standards adopted by the technical committees are circulated to the member bodies for voting. Publication as an International Standard requires approval by at least 75 % of the member bodies casting a vote.

Attention is drawn to the possibility that some of the elements of this part of ISO 9022 may be the subject of patent rights. ISO shall not be held responsible for identifying any or all such patent rights.

International Standard ISO 9022-2 was prepared by Technical Committee ISO/TC 172, *Optics and optical instruments*, Subcommittee SC 1, *Fundamental standards*.

This second edition cancels and replaces the first edition (ISO 9022-2:1994), Tables 2, 3 and 7 of which have been technically revised.

ISO 9022 consists of the following parts, under the general title *Optics and optical instruments — Environmental test methods*:

- *Part 1: Definitions, extent of testing*
- *Part 2: Cold, heat and humidity*
- *Part 3: Mechanical stress*
- *Part 4: Salt mist*
- *Part 5: Combined cold, low air pressure*
- *Part 6: Dust*
- *Part 7: Drip, rain*
- *Part 8: High pressure, low pressure, immersion*
- *Part 9: Solar radiation*
- *Part 10: Combined sinusoidal vibration and dry heat or cold*
- *Part 11: Mould growth*
- *Part 12: Contamination*
- *Part 13: Combined shock, bump or free fall and dry heat or cold*
- *Part 14: Dew, hoarfrost, ice*
- *Part 15: Combined digitally controlled broad-band random vibration and dry heat or cold*
- *Part 16: Combined bounce or steady-state acceleration and dry heat or cold*
- *Part 17: Combined contamination, solar radiation*
- *Part 18: Combined damp heat and low internal pressure*
- *Part 19: Temperature cycles combined with sinusoidal or random vibration*

ISO 9022-2:2002(E)

- *Part 20: Humid atmosphere containing sulfur dioxide or hydrogen sulfide*
- *Part 21: Combined low pressure and ambient temperature or dry heat*

Introduction

Optical instruments are affected during their use by a number of different environmental parameters which they are required to resist without significant reduction in performance.

The type and severity of these parameters depend on the conditions of use of the instrument (for example, in the laboratory or workshop) and on its geographical location. The environmental effects on optical instrument performance in the tropics and subtropics are totally different from those found when they are used in the arctic regions. Individual parameters cause a variety of different and overlapping effects on instrument performance.

The manufacturer attempts to ensure, and the user naturally expects, that instruments will resist the likely rigours of their environment throughout their life. This expectation can be assessed by exposure of the instrument to a range of simulated environmental parameters under controlled laboratory conditions. The severity of these conditions is often increased to obtain meaningful results in a relatively short period of time.

In order to allow assessment and comparison of the response of optical instruments to appropriate environmental conditions, ISO 9022 contains details of a number of laboratory tests which reliably simulate a variety of different environments. The tests are based largely on IEC standards, modified where necessary to take into account features special to optical instruments.

It should be noted that, as a result of continuous progress in all fields, optical instruments are no longer only precision-engineered optical products, but, depending on their range of application, also contain additional assemblies from other fields. For this reason, the principal function of the instrument must be assessed to determine which International Standard should be used for testing. If the optical function is of primary importance, then ISO 9022 is applicable, but if other functions take precedence then the appropriate International Standard in the field concerned should be applied. Cases may arise where application of both ISO 9022 and other appropriate International Standards will be necessary.

Optics and optical instruments — Environmental test methods —

Part 2:

Cold, heat and humidity

1 Scope

This part of ISO 9022 specifies methods for the testing of optical instruments and instruments containing optical components, under equivalent conditions, for their ability to resist temperature and air humidity.

The purpose of testing is to investigate to what extent the optical, thermal, mechanical, chemical and electrical performance characteristics of the specimen are affected by temperature and/or humidity.

2 Normative reference

The following normative document contains provisions which, through reference in this text, constitute provisions of this part of ISO 9022. For dated references, subsequent amendments to, or revisions of, this publication do not apply. However, parties to agreements based on this part of ISO 9022 are encouraged to investigate the possibility of applying the most recent edition of the normative document indicated below. For undated references, the latest edition of the normative document referred to applies. Members of ISO and IEC maintain registers of currently valid International Standards.

ISO 9022-1:1994, *Optics and optical instruments — Environmental test methods — Part 1: Definitions, extent of testing*

3 General information and test conditions

The specimen is exposed to climatic stress in conditioning chambers or cabinets providing air circulation.

The size of the specimens and their arrangement shall be such as to ensure a uniform conditioning of all specimens. Where moisture condensation is likely to occur, the condensate shall be prevented from dripping onto the specimen.

Where heat-dissipating specimens are involved, the relevant specification shall state the number, method of installation and location of the heat sensors.

WARNING — Persons entering test chambers with dew-point temperatures of equal to or greater than 38 °C must be equipped with breathing apparatus (e.g. conditioning methods 12, 13 and 16).

4 Conditioning

4.1 General

The required exposure time shall not commence until all parts of the specimen have reached a temperature within at least 3 K of the test chamber temperature. For heat-dissipating specimens, the period of exposure or dwell time (conditioning methods 14 and 15) shall not begin, or end, until the temperature of the specimen changes not more than 1 K within 1 h at the stabilized test chamber temperature. The last hour of the temperature soaking time shall be considered to be the first hour of the exposure period.

4.2 Constant stress conditions

4.2.1 General

During exposure to constant stress conditions, the temperature shall be changed sufficiently slowly to prevent the specimen from being damaged. When testing to conditioning methods 11 and 12, the maximum relative humidity also applies to the temperature change phase. The relevant specification shall state whether condensation of dew on the specimen is acceptable.

4.2.2 Conditioning method 10: Cold

See Table 1.

Table 1 — Degrees of severity for conditioning method 10: Cold

Degree of severity	01	02	03	04	05	06	07	08	09	10
Test chamber temperature °C	-0 ± 3	-10 ± 3	-15 ± 3	-20 ± 3	-25 ± 3	-30 ± 3	-35 ± 3	-40 ± 3	-55 ± 3	-65 ± 3
Exposure time h	16									
State of operation	0 or 1 or 2 ^a									0 or 1

^a When testing to degree of severity 09 is required, state of operation 2 should be justified in the relevant specification.

4.2.3 Conditioning method 11: Dry heat

See Table 2.

Table 2 — Degrees of severity for conditioning method 11: Dry heat

Degree of severity	01	02	03	04	05	06	07	08
Test chamber temperature °C	10 ± 2	40 ± 2	55 ± 2	63 ± 2	70 ± 2	85 ± 2	70 ± 2	85 ± 2
Relative humidity %	< 40							
Exposure time h	16				6	6	2	2
State of operation	0 or 1 or 2					0 or 1	0 or 1 or 2	0 or 1

4.2.4 Conditioning method 12: Damp heat

See Table 3.

Table 3 — Degrees of severity for conditioning method 12: Damp heat

Degree of severity	01	02	03	04	05	06	07
Climatic conditions	40 °C ± 2 °C and 90 % to 95 % r.h.					55 °C ± 2 °C and 90 % to 95 % r.h.	
Exposure time	24 h	4 d	10 d	21 d	56 d	6 h	16 h
State of operation	0 or 1 or 2 ^a						

^a State of operation 2 during the last 4 h of exposure only.

4.2.5 Conditioning method 13: Condensed water

See Table 4.

Table 4 — Degrees of severity for conditioning method 13: Condensed water

Degree of severity	01	02	03	04	05	06
Climatic conditions	40 °C ± 2 °C and approximately 100 % relative humidity, including bedewing of specimens					
Exposure time	6 h	16 h	2 d	4 d	8 d	16 d
State of operation	0 or 1 or 2 ^a					
^a State of operation 2 during the last 4 h of exposure only.						

4.3 Cycling exposure conditions

4.3.1 General

When applying conditioning methods 14 and 15, the specimens shall have reached a temperature at least within 3 K of the test chamber temperatures t_1 and t_2 not later than at the end of the dwell times shown in the respective tables. If the requirement cannot be met, owing to large-sized specimens, a pre-test may be performed to determine the dwell times required.

When applying conditioning method 15, intermediate storage (e.g. overnight) will be acceptable at t_2 only.

4.3.2 Conditioning method 14: Slow temperature change

See Table 5 and Figure 1.

Table 5 — Degrees of severity for conditioning method 14: Slow temperature change

Degree of severity		01	02	03	04	05	06	07	08	09
Test chamber temperature	$^{\circ}\text{C}$ t_2	40 ± 2	55 ± 2	70 ± 2	55 ± 2	63 ± 2	70 ± 2	70 ± 2	70 ± 2	85 ± 2
	t_1	-10 ± 3	-25 ± 3	-25 ± 3	-40 ± 3	-35 ± 3	-40 ± 3	-50 ± 3	-65 ± 3	-65 ± 3
Temperature difference	K	50	80	95	95	98	110	120	135	150
Number of cycles		5								
Dwell time at t_1 and t_2		Until specimen has reached a temperature at least within 3 K of the test chamber temperature but not less than 2,5 h. For heat-dissipating specimens, refer to 4.1.								
Test chamber temperature change rate		Between 0,2 K/min and 2 K/min.								
State of operation		0 or 1 or 2 ^a								
^a When testing to degrees of severity 04 to 09, state of operation 2 should be justified in the relevant specification.										

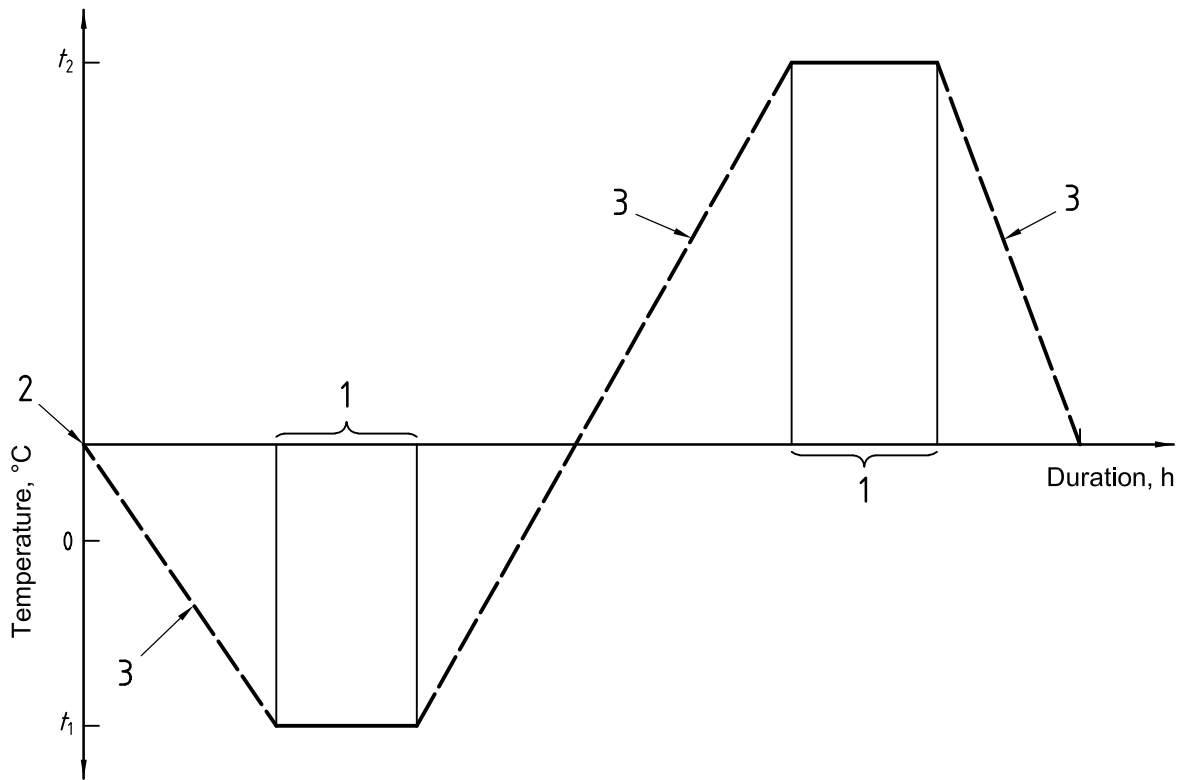

Key

- 1 Dwell time
- 2 Ambient atmospheric conditions
- 3 0,2 K/min to 2 K/min

Figure 1 — Cycling curve for conditioning method 14 (slow temperature change)

4.3.3 Conditioning method 15: Rapid temperature change (temperature shock)

See Table 6 and Figure 2.

Table 6 — Degrees of severity for conditioning method 15: Temperature shock

Degree of severity		01	02	03	04	05
Test chamber temperature	$^{\circ}\text{C } t_2$	20 ± 2	40 ± 2	55 ± 2	70 ± 2	70 ± 2
	t_1	-10 ± 2	-25 ± 2	-40 ± 2	-55 ± 2	-65 ± 2
Temperature difference	K	30	65	95	125	135
Number of cycles		5				
Dwell time at t_1 and t_2		Until specimen has reached a temperature at least within 3 K of the test chamber temperature but not less than 2,5 h. For heat-dissipating specimens, refer to 4.1.				
Time allowed for temperature change rate		Max. 20 s for equipment of up to 10 kg; beyond 10 kg as short as possible but not more than 10 min. The time actually taken should be documented in the test report.				
State of operation		0 or 1 or 2 ^a				
^a State of operation 2 should be justified in the relevant specification.						

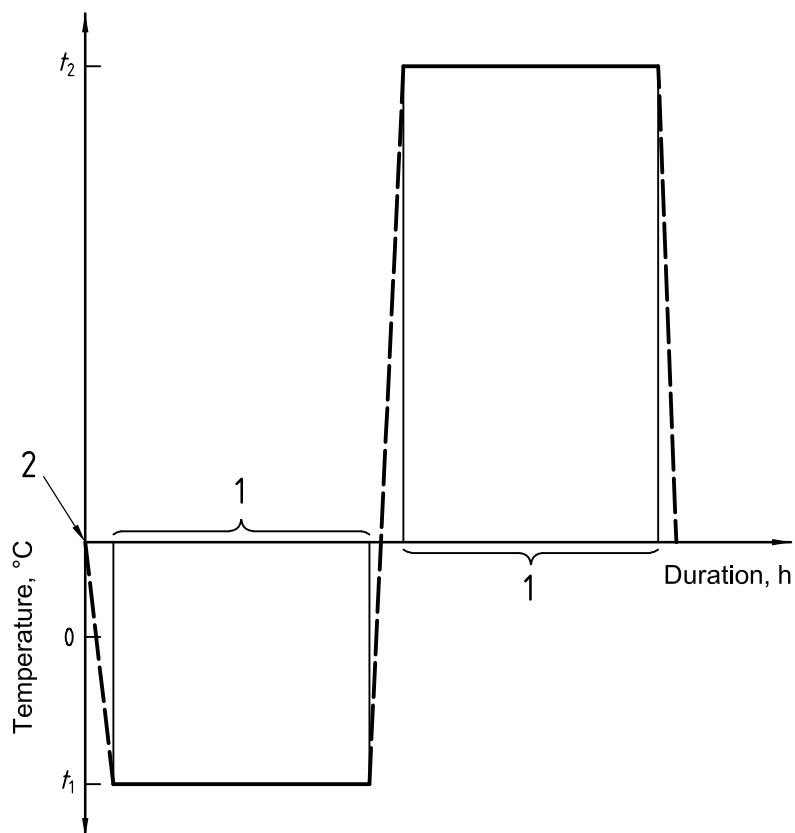

Key

- 1 Dwell time
- 2 Ambient atmospheric conditions

Figure 2 — Cycling curve for conditioning method 15 (temperature shock)

4.3.4 Conditioning method 16: Damp heat, cyclic

See Table 7.

Table 7 — Degrees of severity for conditioning method 16: Damp heat, cyclic

Degree of severity	01	02 ^a	03 ^a	04 ^b	05 ^b	06 ^b	07 ^b
Cycling climatic conditions	23 °C ± 2 °C and 80 % to 85 % r.h. 40 °C ± 2 °C and 90 % to 95 % r.h. including bedewing			23 °C ± 2 °C 55 °C ± 2 °C		23 °C ± 2 °C 70 °C ± 2 °C	
Number of cycles	5	10	20	5	10	5	10
State of operation	0 or 1 or 2 ^c			0 or 1			
^a Refer to Figure 3 for procedure. ^b Refer to Figure 4 for procedure and for relative humidity. ^c State of operation 2 from the 15 th to 19 th hour of one cycle only.							

The cycling curve for degrees of severity 01 to 03 is shown in Figure 3; curves for degrees of severity 04 to 07 are shown in Figure 4.

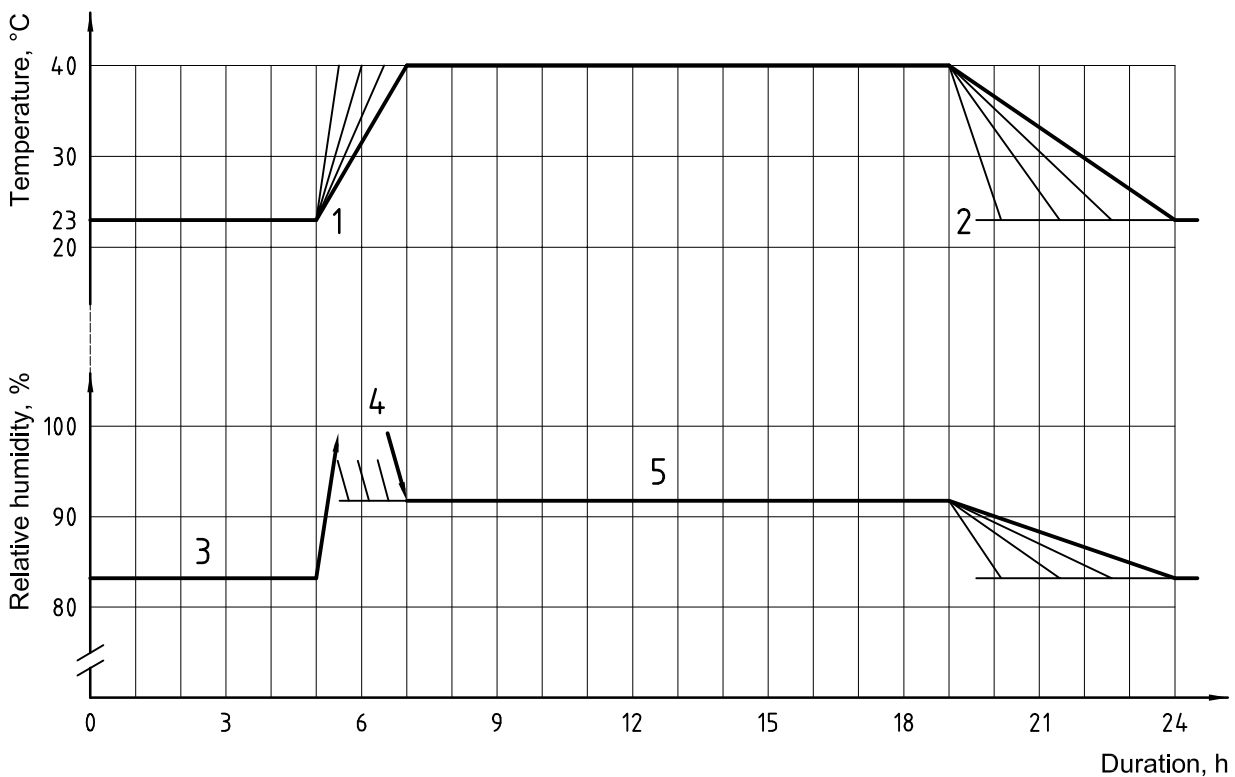

Key

- 1 Change to 40 °C ± 2 °C temperature and 90 % to 95 % relative humidity
- 2 Change to 23 °C ± 2 °C temperature and 80 % to 85 % relative humidity
- 3 80 to 85
- 4 Bedewing
- 5 90 to 95

Figure 3 — Cycling curve for conditioning method 16: Damp heat, cyclic (degrees of severity 01 to 03)

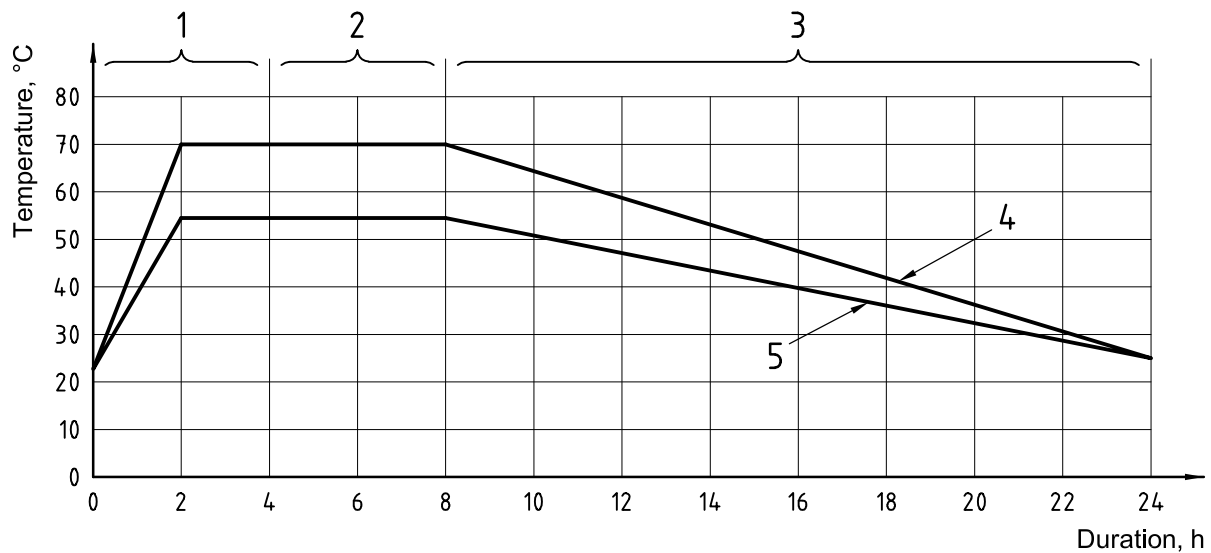
**Key**

- 1 \geq 85 % relative humidity
- 2 90 % to 95 % relative humidity
- 3 \geq 85 % relative humidity without bedewing
- 4 06 and 07
- 5 04 and 05

Figure 4 — Cycling curve for conditioning method 16: Damp heat, cyclic (degrees of severity 04 to 07)

5 Procedure

5.1 General

The test shall be conducted in accordance with the requirements of the relevant specification and with ISO 9022-1.

5.2 Pre-test

For conditioning methods 14 and 15, the dwell times for large-sized specimens shall be determined in a pre-test and documented in the test report.

6 Environmental test code

The environmental test code shall be as defined in ISO 9022-1.

EXAMPLE The environmental test of optical instruments for resistance to slow temperature change, in accordance with conditioning method 14, degree of severity 02, state of operation 1, shall be identified as:

Environmental test ISO 9022-14-02-1

7 Specification

The relevant specification shall contain the following details:

- a) environmental test code;
- b) number of specimens;

ISO 9022-2:2002(E)

- c) number, location and method of installation of the temperature sensors required for heat-active specimens;
- d) conditioning method 10: justification of state of operation 2 at degree of severity 09 or 10. Determination of additional requirements for testing a cold specimen in an open cold chamber or outside the cold chamber and for protecting the specimen against hoarfrost or bedewing;
- e) conditioning method 12: acceptability of dew condensation;
- f) conditioning method 14, degrees of severity 04 to 09: justification of state of operation 2 if that state of operation is required;
- g) conditioning method 15: the time of temperature change actually required for specimens beyond 10 kg mass shall be stated in the test report; justification of state of operation 2 at all degrees of severity;
- h) conditioning method 16, degrees of severity 04 to 07: relative humidity values other than those shown in Figure 4 shall be specified;
- i) preconditioning;
- j) type and scope of initial test;
- k) state of operation 2: period of operation;
- l) state of operation 2: type and scope of intermediate test;
- m) recovery;
- n) type and scope of final test;
- o) criteria of evaluation;
- p) type and scope of test report.

.....

ISO 9022-2:2002(E)

ICS 37.020

Price based on 8 pages

© ISO 2002 – All rights reserved