

INTERNATIONAL STANDARD

**ISO
9021**

First edition
1988-09-15



INTERNATIONAL ORGANIZATION FOR STANDARDIZATION
ORGANISATION INTERNATIONALE DE NORMALISATION
МЕЖДУНАРОДНАЯ ОРГАНИЗАЦИЯ ПО СТАНДАРТИЗАЦИИ

Motorcycles — Controls — Types, positions and functions

Motorcycles — Commandes — Types, positions et fonctions

Reference number
ISO 9021 : 1988 (E)

Foreword

ISO (the International Organization for Standardization) is a worldwide federation of national standards bodies (ISO member bodies). The work of preparing International Standards is normally carried out through ISO technical committees. Each member body interested in a subject for which a technical committee has been established has the right to be represented on that committee. International organizations, governmental and non-governmental, in liaison with ISO, also take part in the work. ISO collaborates closely with the International Electrotechnical Commission (IEC) on all matters of electrotechnical standardization.

Draft International Standards adopted by the technical committees are circulated to the member bodies for approval before their acceptance as International Standards by the ISO Council. They are approved in accordance with ISO procedures requiring at least 75 % approval by the member bodies voting.

International Standard ISO 9021 was prepared by Technical Committee ISO/TC 22, *Road vehicles*.

Annexes A and B form integral parts of this International Standard.

Motorcycles — Controls — Types, positions and functions

1 Scope

This International Standard lays down the types, positions and functions of the driver-operated controls on a two-wheeled motorcycle, in order to facilitate use. Annex A gives individual requirements for levers and pedals, including the maximum and minimum dimensions and clearances. Annex B specifies controls, indicators and telltales for which identification is obligatory and the appropriate graphical symbols.

This International Standard applies to those controls which, when fitted, are commonly used by the driver of a two-wheeled motorcycle (as defined in ISO 3833).

The definition or specification of a control does not signify the mandatory presence of each and every control listed in this International Standard on a vehicle.

2 Normative references

The following standards contain provisions which, through reference in this text, constitute provisions of this International Standard. At the time of publication, the editions indicated were valid. All standards are subject to revision, and parties to agreements based on this International Standard are encouraged to investigate the possibility of applying the most recent editions of the standards listed below. Members of IEC and ISO maintain registers of currently valid International Standards.

ISO 3833 : 1977, *Road vehicles — Types — Terms and definitions*.

ISO 6727 : 1981, *Road vehicles — Motorcycles — Symbols for controls, indicators and telltales*.

3 Definitions

For the purposes of this International Standard, the following definitions apply.

3.1 vehicle : Two-wheeled motorcycle as defined in ISO 3833.

3.2 control : Device operated by the driver's hand or foot to obtain functions for which the different mechanisms of the vehicle are designed (accelerator, brake, etc.).

3.3 handlebars : Any part of the bar or bars connected to the fork top by means of which the vehicle is steered.

3.4 handgrip : Part of the handlebars, furthest from the centre, by which the driver holds the handlebars.

3.4.1 rotating handgrip : Handgrip, operating some functional mechanism of the vehicle, which is free to rotate round the handlebars when so turned by the driver.

3.5 frame : Any part of the frame, chassis or cradle of the vehicle to which the engine and/or transmission unit and/or the engine and transmission unit itself are attached.

3.6 lever : Device consisting of an arm turning on a fulcrum, by means of which some functional mechanism of the vehicle is operated.

3.6.1 hand lever : Lever operated by the driver's hand.

NOTE — Unless otherwise stated, a hand lever is operated by compression (i.e. moving the apex of the lever towards the supporting structure), e.g. for braking or declutching.

3.6.2 foot lever : Lever operated by contact between the driver's foot and a spur projecting from the lever arm.

3.6.3 pedal : Lever operated by contact between the driver's foot and a pad on the lever, so placed as to allow pressure to be applied to the lever arm.

NOTE — Unless otherwise stated, a pedal is operated by depression, e.g. for braking.

3.6.4 rocker arm : Lever, pivoted at or near its centre and having a pad or spur at each end, operated by contact between the driver's foot and the pads or spurs. (See annex A, A.2.2.)

3.7 footrest : Projection on either side of the vehicle on which the driver places his feet when seated in the driving position.

3.8 platform : Part of the vehicle, in the case of a vehicle not equipped with footrests, on which the driver places his feet when seated in the driving position.

ISO 9021 : 1988 (E)

3.9 combined service brake : System of operation whereby both the front and the rear brakes of the vehicle are brought into operation, at least partially, by the use of only one control.

3.10 indicator : Device which presents information on the functioning or situation of a system or part of a system.

3.11 telltale : Optical signal which indicates the actuation of a device, its correct or defective functioning or condition, or its failure to function.

3.12 symbol : Diagram from which to identify a control, indicator or telltale.

3.13 Orientation and directions

3.13.1 right side/left side : Right or left side respectively of the longitudinal median plane of the vehicle when facing forward.

3.13.2 forward (in relation to the handlebars) : Part of the handlebars lying furthest from the driver when seated in the driving position.

3.13.3 clockwise : Clockwise around the axis when viewed from the upper or outer side of the part considered.

3.13.4 anticlockwise : Opposite of that defined in 3.13.3.

4 Requirements — General

4.1 Type and position

When a control is fitted, it shall be of the type and in the position specified in clause 5.

4.2 General design

4.2.1 All the controls specified in 5.1, 5.2, 5.3 and 5.4 shall be within the driver's reach when seated in the driving position and shall be located in the positions or areas specified in those sub-clauses.

4.2.2 The position of the controls on the handlebars of the

- front brake (see 5.2.1),
- rear brake (alternative) (see 5.2.2.2),
- clutch (see 5.3.1),
- horn (see 5.4.1),
- main-/dipped-beam control (see 5.4.2.2),
- direction-indicator control (see 5.4.3)

shall be such that they can be reached without the driver moving his hand from the respective handgrip.

4.2.3 The controls detailed in 5.2.1, 5.2.2, 5.2.3, 5.3.1 and 5.3.2.1.1 shall be so designed as to comply with the requirements of clause A.1 (hand levers) or A.2 (foot levers and pedals) respectively.

4.3 Access

The driver's reach to the controls shall not be impeded by intrusion of any other control or any part of the structure of the vehicle.

4.4 Identification

The identification of the controls, indicators and telltales, if fitted to the vehicle, shall be in accordance with the requirements of annex B.

5 Requirements — Individual

5.1 Engine controls

5.1.1 Starting

5.1.1.1 Engine ignition switch

No special requirement but, for a rotary switch, motion shall be clockwise from the ignition "off" position to the ignition "on" position.

5.1.1.2 Starter switch

No special requirement.

5.1.1.3 Combined ignition/starter switch

In the case of a rotary switch, motion shall be clockwise, passing from ignition "off" to ignition "on" and then to the starter-energizing position.

5.1.2 Speed

5.1.2.1 Speed control (accelerator or throttle)

The speed of the engine shall be adjusted by a hand-operated control.

Position of control : on handlebars, right side.

Type of control : rotating handgrip.

Direction of rotation : anticlockwise to increase speed.

5.1.3 Stop

5.1.3.1 Engine cut-out

As a means of stopping the engine, alternative to the engine ignition switch (see 5.1.1.1) or a decompression valve control (see 5.1.3.2), the vehicle may be equipped with an electrical power cut-out.

Position of control : on handlebars, right side.

5.1.3.2 Manual decompression control

Position of control : on handlebars.

Type of control : lever, or rotating handgrip, provided that it is combined with the speed control.

5.2 Brakes

5.2.1 Front (wheel) brake

Position of control : on handlebars, right side, forward.

Type of control : hand lever.

5.2.2 Rear (wheel) brake

5.2.2.1 Vehicles with hand-operated clutch

Position of control : on frame, right side.

Type of control : pedal.

5.2.2.2 Vehicles without hand-operated clutch

Such vehicles may conform to the requirement either in a) or b).

- a) Position of control : on handlebars, left side, forward.

Type of control : hand lever.

- b) Position of control : on frame, right side.

Type of control : pedal.

5.2.2.3 Additional rear brake

Nothing in the requirements of 5.2.1 or 5.2.2 shall prohibit a vehicle, equipped with a pedal-operated rear (wheel) brake, from being equipped with an additional rear brake.

Position of control : handlebars, left side, forward.

5.2.3 Combined service brake

Nothing in the requirements of 5.2.1 or 5.2.2 shall prohibit a vehicle from being equipped with a combined service brake, the position and type of control of which shall be as specified in 5.2.1 or 5.2.2.

5.2.4 Parking brake

Position of control : no special requirement.

Type of control : no special requirement.

5.3 Transmission

5.3.1 Clutch

The manual operating control shall be as follows.

Position of control : on handlebars, left side, forward.

Type of control : hand lever.

This requirement shall not prohibit, as a device for actuating the clutch mechanism, the use of a combined foot lever control for both clutch operation and gear selection.

The position for such a combined foot lever shall be as specified in 5.3.2.1.1.

5.3.2 Gear selection

5.3.2.1 Mechanically selected gears

5.3.2.1.1 In the case of vehicles equipped with a gear-selection control operated by a foot lever either in conjunction with or independently of the clutch control, the vehicle shall conform to the following requirements.

Position of control : on frame, left side.

Type of control : foot lever or rocker arm.

Method of operating control : movement of the foot lever or the forward part of the rocker arm upward shall, progressively, select gears giving an increased forward speed and conversely for the selection of gears giving a reduced forward speed. Within the range of movement between the lowest and the highest gear, a separate detent position shall be provided for neutral.

5.3.2.1.2 In the case of vehicles equipped with a gear-selection control operated in conjunction with a hand-operated clutch, the vehicle shall conform to the following requirements.

Position of control : on handlebars, left side.

Type of control : rotating handgrip.

Method of operating control : rotation of the handgrip anti-clockwise shall, progressively, select gears giving an increased forward speed and conversely for a reduced forward speed. Within the range of movement between the lowest and highest gears, a separate detent position shall be provided for neutral.

5.3.2.2 Automatically selected gears

In the case of vehicles equipped with automatic or semi-automatic transmission and/or gear-boxes, there shall be no specific requirements for the position, or the type of control (if any) used to engage the transmission or select the gears.

5.4 Lighting and signalling controls

5.4.1 Horn

5.4.1.1 For vehicles with gear selection operated by a foot lever and/or independently of the clutch, the vehicle shall meet the following requirements.

Position of control : on handlebars, left side.

Type of control : button or switch.

5.4.1.2 For vehicles with gear selection operated in conjunction with a hand-operated clutch, the vehicle shall meet the following requirements.

Position of control : on handlebars, right side.

Type of control : button or switch.

5.4.2 Lighting

5.4.2.1 Light control switch

In the case of a rotary switch, clockwise operation shall illuminate, successively, the vehicle's position (side-) lights and then the headlights.

This requirement does not preclude additional switch positions, provided that they are clearly marked.

The light control switch may be combined with the ignition switch.

5.4.2.2 Main-beam/dipped-beam switch

5.4.2.2.1 For vehicles with gear selection operated by a foot lever and/or independently of the clutch, the vehicle shall meet the following requirements.

Position of control : on handlebars, left side.

Type of control : no special requirement.

5.4.2.2.2 For vehicles with gear selection operated in conjunction with a hand-operated clutch, the vehicle shall meet the following requirements.

Position of control : on handlebars, right side.

Type of control : no special requirement.

5.4.2.3 Headlight flasher

The control for this device, for which there is no special requirement as to type, shall be adjacent to the main-beam/dipped-beam switch or an additional function of it.

5.4.3 Direction-indicator switch

Position of control : on handlebars

The control shall be so designed that, when viewed from the driver's seat, operation of the left-hand portion, or movement to the left actuates the left side direction-indicators and the inverse for the right side direction-indicators.

The control shall be clearly marked to show the side of the vehicle on which the indicators are working.

5.5 Fuel supply controls

5.5.1 Cold starting device

No special requirement as to type.

Any manual control shall be so placed as to be reasonably and conveniently accessible to the driver.

5.5.2 Manual fuel shut-off control

5.5.2.1 The control shall have separate, positive positions for

- "off";
- "on";
- "reserve" (where a reserve supply is provided).

The control shall be "on" when the fuel-flow points downstream from the fuel-tank to the engine : it shall be "off" when it is perpendicular to fuel-flow : it shall be on "reserve" (when applicable) when it points upstream of the fuel-flow.

5.5.2.2 Where a reserve supply is provided, the driver shall be able to switch to it while seated in the driving position.

Annex A (normative)

Special requirements for levers and pedals

A.1 Hand levers

A.1.1 Maximum dimension

A.1.1.1 The maximum dimension between the hand lever forward face and the handgrip rearward face shall not exceed 135 mm, measured perpendicular to the axis of the handgrip, at any point between the mid-point of the handgrip and the end nearest the fulcrum [see dimension *A* in figure A.1 a)].

A.1.1.2 This dimension may increase beyond the mid-point of the handgrip towards the hand lever open end.

A.1.2 Minimum dimension

A.1.2.1 The minimum dimension (clearance) between the hand lever rearward face and the handgrip forward face shall not be less than 45 mm at any point between the outer end and the mid-point of the handgrip [see dimension *B* in figure A.1 b)].

A.1.2.2 This dimension may decrease inside the mid-point of the hand lever towards the fulcrum, but shall in no case be less than 25 mm.

A.1.3 Hand lever end

The outer end of the hand lever shall not project beyond the outer end of the handgrip by more than 30 mm when the hand lever is at maximum compression [see dimension *C* in figure A.1 c)].

A.2 Foot levers and pedals

A.2.1 Foot levers

A.2.1.1 The maximum dimension between the rearward face of the foot lever spur and the rearward face of the footrest shall not exceed 200 mm at any point on the spur (see dimension *D* in figure A.2).

A.2.1.2 The minimum dimension (clearance) between the rearward face of the foot lever spur and the forward face of the footrest shall not be less than 105 mm at any point on the spur (see dimension *E* in figure A.2).

A.2.2 Rocker arms

A.2.2.1 For the front end of the rocker arm, the dimension between the pad rearward end, or the spur rearward face, and the footrest rearward face shall not be more than 200 mm nor less than 60 mm (see dimension *F* in figure A.3).

A.2.2.2 For the rearward end of the rocker arm, the dimension between the pad forward end, or the spur forward face, and the footrest rearward face shall not be more than 100 mm nor less than 50 mm (see dimension *G* in figure A.3).

A.2.3 Pedals

A.2.3.1 Vehicles with footrest

A.2.3.1.1 The maximum dimension between the rearward end of the pedal pad and the footrest rearward face shall not exceed 170 mm at any point (see dimension *H* in figure A.4).

A.2.3.1.2 The minimum dimension (clearance) between the rearward part of the pedal pad and the footrest forward face shall not be less than 50 mm at any point (see dimension *I* in figure A.4).

A.2.3.2 Vehicles with a platform

A.2.3.2.1 The maximum dimension between the platform surface and the highest point of the pedal pad, measured perpendicular to the surface of the platform adjacent to the pedal, shall not exceed 105 mm (see dimension *J* in figure A.5).

A.2.3.2.2 The extreme outer edge of the pedal pad shall not project more than 25 mm beyond the platform outer edge (see dimension *K* in figure A.5).

A.2.4 Adjustment of footrests

Where the footrests are adjustable, the dimensions specified in A.2.1, A.2.2 and A.2.3 shall be measured at the normal footrest adjustment points (or as stated in the "Owner's Manual") and with the foot lever, rocker arm or pedal in the position specified by the manufacturer.

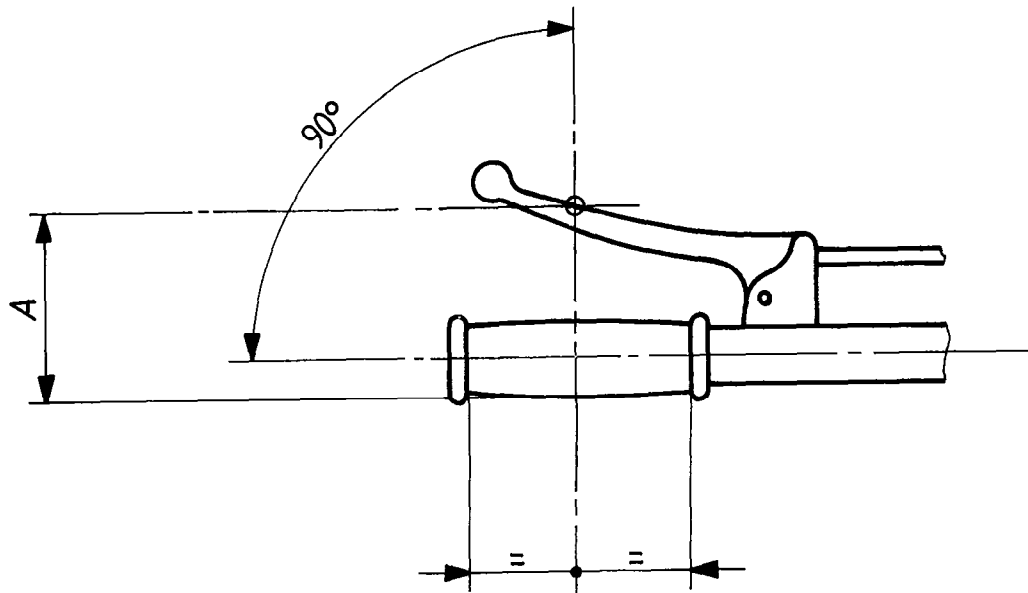

a)

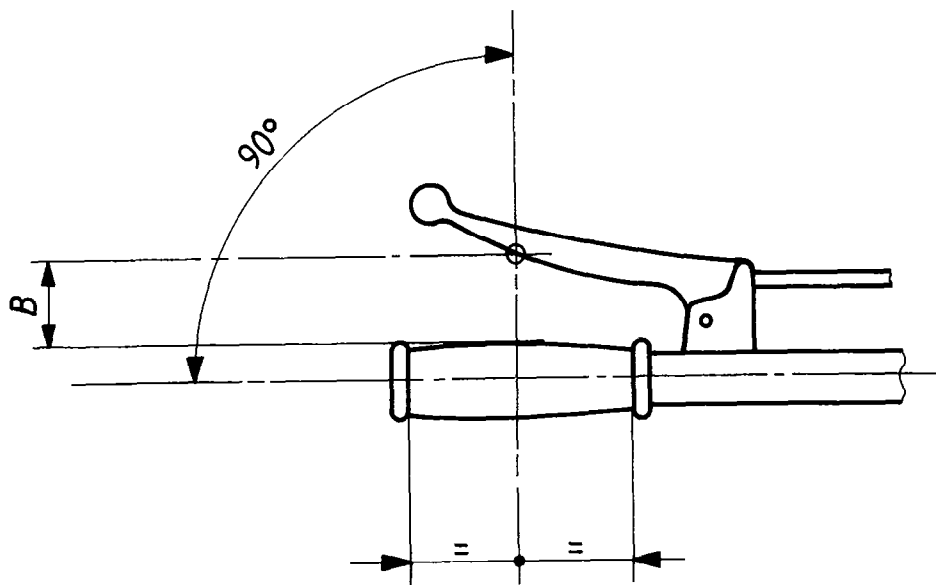

b)

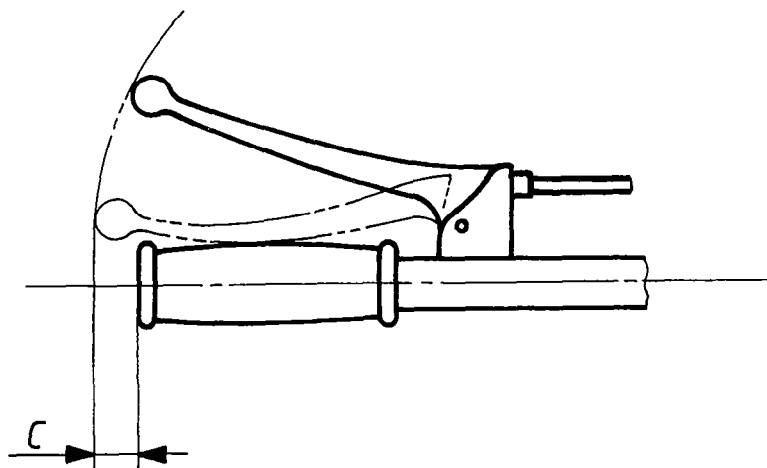

c)

Figure A.1

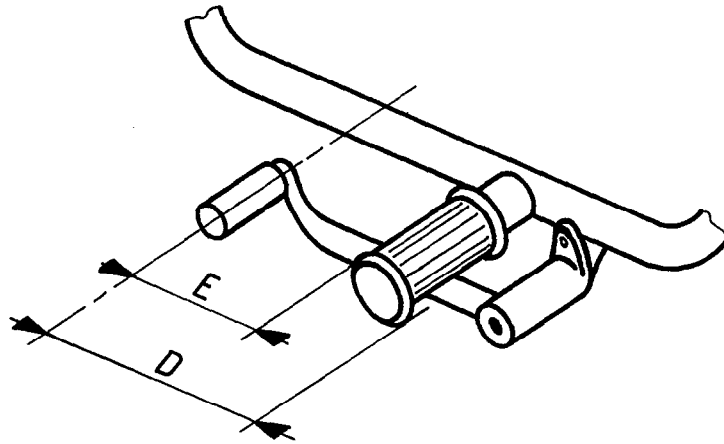

Figure A.2

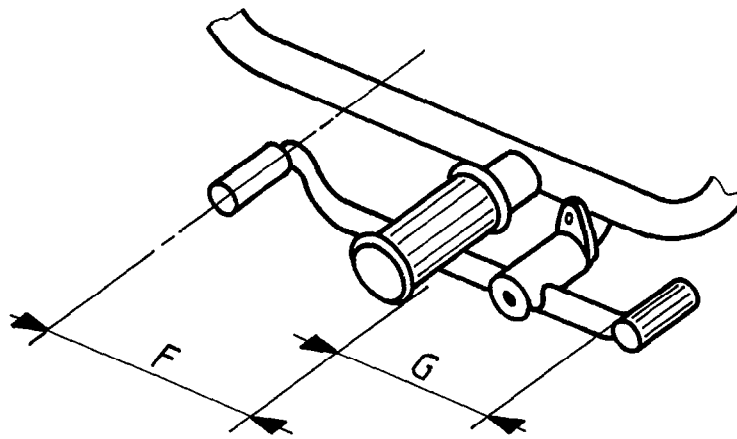

Figure A.3

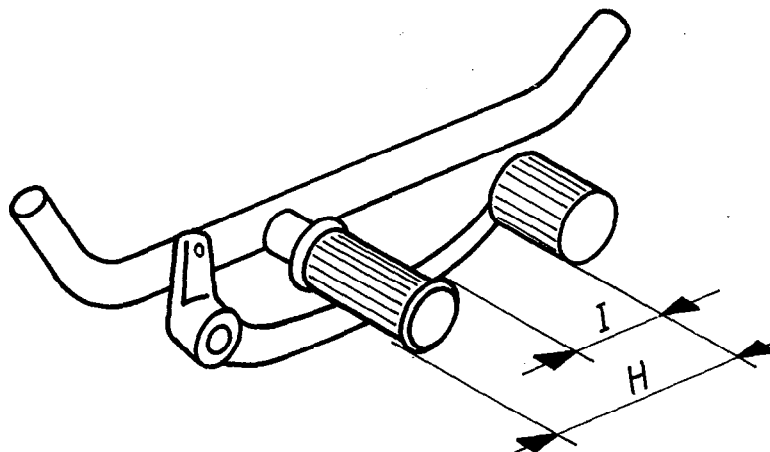

Figure A.4

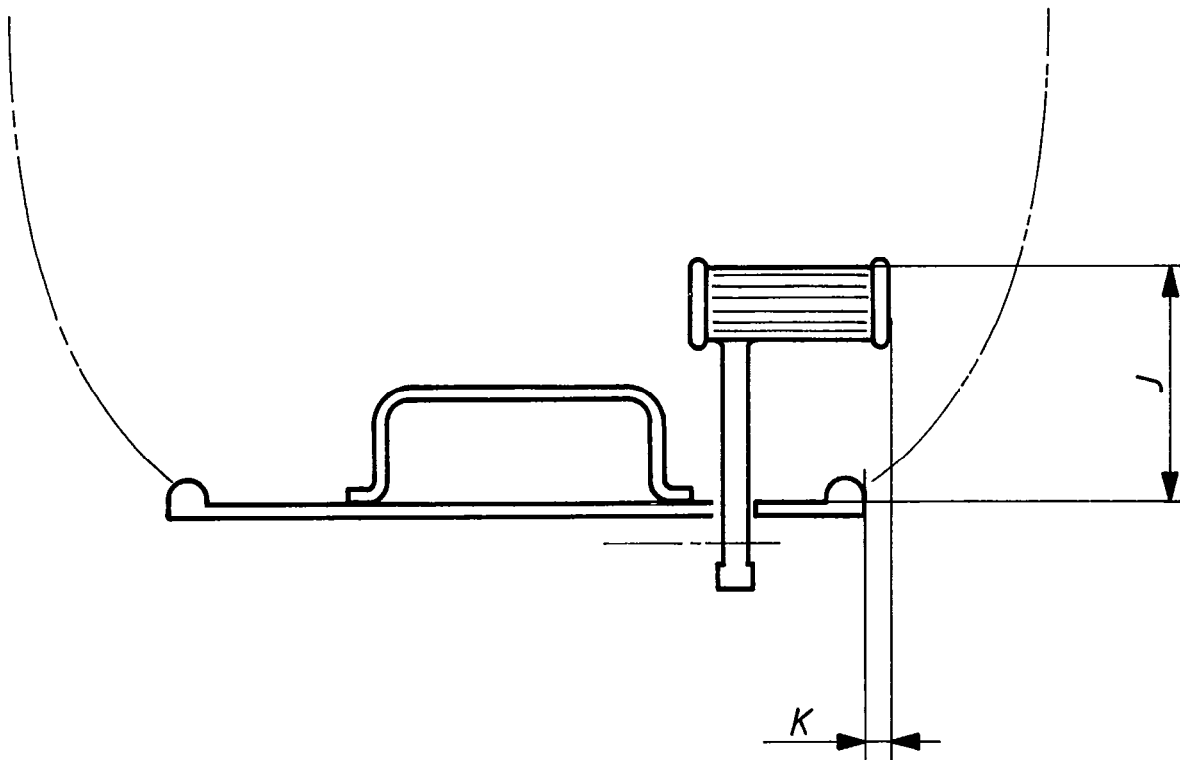

Figure A.5

Annex B (normative)

Controls, indicators and telltales for which (when fitted) identification is mandatory, and symbols to be used

B.1 Requirements

The requirements of ISO 6727 shall be respected for controls, indicators and telltales for which identification is mandatory.

B.2 Symbols

The symbols to be used to identify controls, indicators and telltales shall be those specified in ISO 6727.

ISO 9021 : 1988 (E)

UDC 629.118.6-514

Descriptors : road vehicles, motorcycles, control devices, specifications.

Price based on 8 pages
