**Road vehicles — Electrical
performance of starter motors — Test
methods and general requirements**

*Véhicules routiers — Caractéristiques électriques des démarreurs —
Méthodes d'essai et conditions générales*





COPYRIGHT PROTECTED DOCUMENT

© ISO 2014

All rights reserved. Unless otherwise specified, no part of this publication may be reproduced or utilized otherwise in any form or by any means, electronic or mechanical, including photocopying, or posting on the internet or an intranet, without prior written permission. Permission can be requested from either ISO at the address below or ISO's member body in the country of the requester.

ISO copyright office
Case postale 56 • CH-1211 Geneva 20
Tel. + 41 22 749 01 11
Fax + 41 22 749 09 47
E-mail copyright@iso.org
Web www.iso.org

Published in Switzerland

Contents

Page

Foreword	iv
1 Scope	1
2 Terms and definitions	1
3 Test conditions	2
3.1 Temperature.....	2
3.2 Measurement accuracy.....	2
3.3 Voltage/current characteristic of starter motor power supply.....	2
3.4 Preparation of test samples.....	3
4 Test benches	3
4.1 General.....	3
4.2 Type 1 test bench.....	4
4.3 Type 2 test bench.....	4
5 Test method	6
5.1 General.....	6
5.2 Test procedure.....	6
6 Measurement correction	7
6.1 General.....	7
6.2 Correction of torque.....	7
6.3 Correction of rotational frequency with temperature.....	9
7 Presentation of results	10
7.1 Power output and efficiency calculation.....	10
7.2 Graphic presentation of starter motor characteristic curves.....	10
7.3 Change of voltage/current characteristic.....	10

Foreword

ISO (the International Organization for Standardization) is a worldwide federation of national standards bodies (ISO member bodies). The work of preparing International Standards is normally carried out through ISO technical committees. Each member body interested in a subject for which a technical committee has been established has the right to be represented on that committee. International organizations, governmental and non-governmental, in liaison with ISO, also take part in the work. ISO collaborates closely with the International Electrotechnical Commission (IEC) on all matters of electrotechnical standardization.

The procedures used to develop this document and those intended for its further maintenance are described in the ISO/IEC Directives, Part 1. In particular the different approval criteria needed for the different types of ISO documents should be noted. This document was drafted in accordance with the editorial rules of the ISO/IEC Directives, Part 2 (see www.iso.org/directives).

Attention is drawn to the possibility that some of the elements of this document may be the subject of patent rights. ISO shall not be held responsible for identifying any or all such patent rights. Details of any patent rights identified during the development of the document will be in the Introduction and/or on the ISO list of patent declarations received (see www.iso.org/patents).

Any trade name used in this document is information given for the convenience of users and does not constitute an endorsement.

For an explanation on the meaning of ISO specific terms and expressions related to conformity assessment, as well as information about ISO's adherence to the WTO principles in the Technical Barriers to Trade (TBT) see the following URL: Foreword - Supplementary information

The committee responsible for this document is ISO/TC 22, *Road vehicles*, Subcommittee SC 3, *Electrical and electronic equipment*.

This third edition cancels and replaces the second edition (ISO 8856:1995), which has been technically revised. It also incorporates the Amendment ISO 8856:1995/Amd1:1997.

Road vehicles — Electrical performance of starter motors — Test methods and general requirements

1 Scope

This International Standard lays down test methods and general requirements for the determination of the electrical characteristics of DC starter motors intended to start internal combustion engines of road vehicles.

2 Terms and definitions

For the purposes of this document, the following terms and definitions apply.

2.1

lock torque

torque of starter motor at the pinion with the armature shaft locked (no rotation)

Note 1 to entry: It is expressed in Nm.

2.2

nominal power

P_{nom}

power declared by the starter motor manufacturer corresponding to the maximum power output at the reference temperature when determined in accordance with this International Standard

Note 1 to entry: It is expressed in W.

2.3

power output

P

power derived from measurements of torque and rotational frequency of the motor pinion shaft

Note 1 to entry: It is expressed in W.

2.4

power supply

battery or battery simulation device which delivers a voltage/current characteristic as defined in this International Standard

2.5

reference temperature

temperature at which the performance curves and nominal power shall be reported

Note 1 to entry: Reference temperature is expressed in °C.

Note 2 to entry: It is equal to 20 °C.

2.6

total resistance of starter motor

R_S

resistance value of the terminal voltage, see [Figure 2](#), divided by the starter motor current (steady state current of solenoid included)

Note 1 to entry: It is expressed in Ω .

2.7 total resistance of power supply at starter motor terminals

R_{BL}
sum of power supply and external line resistance

Note 1 to entry: It is expressed in Ω .

3 Test conditions

3.1 Temperature

3.1.1 Test method A — Continuous mode method

Ensure that all parts of the starter motor are at the same, registered temperature.

To avoid temperature corrections, the starter motor can be preconditioned at (20 ± 2) °C.

3.1.2 Test method B — Discrete point method

Ensure that all parts of the starter motor are at the same, registered temperature.

To avoid temperature corrections, the starter motor can be preconditioned at (20 ± 2) °C.

3.1.3 Test method C — Continuous mode method at cold cranking temperature

The starter motor shall be preconditioned at a specified cold cranking temperature as agreed between starter motor manufacturer and engine manufacturer (e.g. -25 °C \pm 2 °C).

3.2 Measurement accuracy

The overall capability of the test equipment shall enable the parameters to be measured within the accuracy shown in [Table 1](#). This requirement shall be respected through the whole test procedure. The target accuracy should be used for new test equipment.

Table 1 — Measurement accuracy

Parameter	Accuracy	Target accuracy
Current	± 1 %	$\pm 0,5$ %
Voltage	± 1 %	$\pm 0,5$ %
Rotational frequency	± 2 %	± 1 %
Torque	± 2 %	± 1 %
Temperature	± 2 K	± 2 K

3.3 Voltage/current characteristic of starter motor power supply

The voltage/current characteristic of starter motor power supply is a sloping straight line (see [Figure 1](#)). The line is defined at 20 °C either by two pairs of values $[(U_1, I_1)$ and $(U_2, I_2)]$, or by one pair of values (U, I) and the internal resistance of the starter motor power supply.

The voltage values $(U_1$ and $U_2)$ shall be measured at the starter motor terminals.

The voltage/current characteristic shall be selected from [Table 2](#) without exceeding the values stated by the starter motor manufacturer.

If required, other voltage/current characteristics can be used as agreed between the starter motor manufacturer and the vehicle manufacturer.

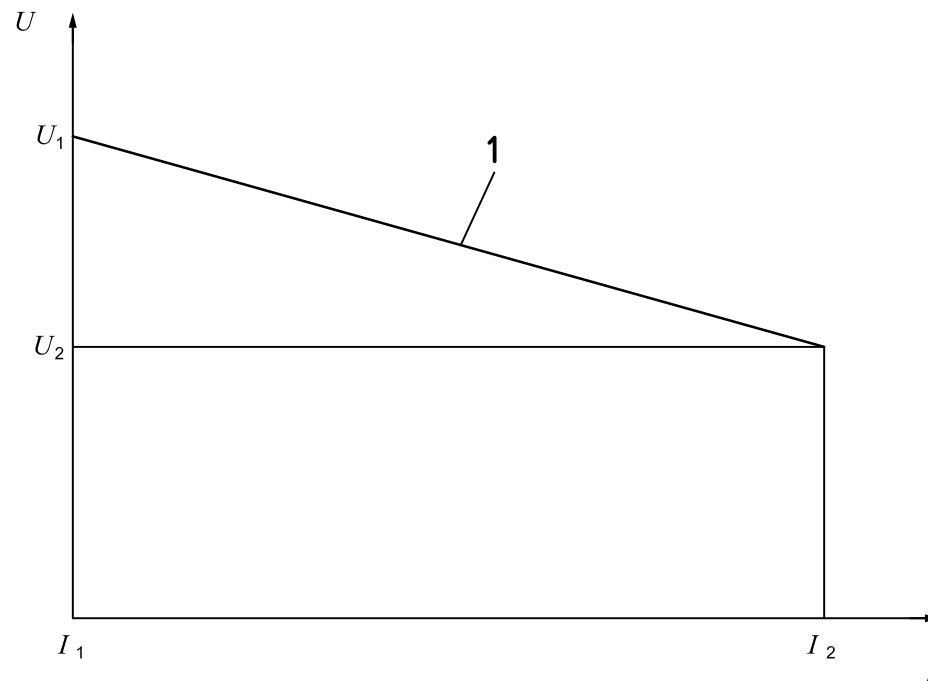
**Key**

1 at 20 °C

Figure 1 — Voltage/current characteristic of starter motor power supply**3.4 Preparation of test samples**

For new starter motors, it is necessary to perform a run-in procedure in order to ensure a stable performance. One example for such a run-in procedure is described below.

Starter motor should be run-in with 40 cycles as follows:

- a) 2 s running at a torque equal to 25 % of the lock torque value;
- b) 13 s rest.

Cooling is permitted during this preparation. The lock torque shall be measured using an appropriate power supply (see [Table 2](#)).

Other preparation test conditions can be used if equivalent or better effect on stabilization of starter performance is confirmed.

4 Test benches**4.1 General**

There are two types of test bench which can be used.

On either type, torque shall be measured either directly as the reaction torque of the starter motor, or at the drive gear shaft.

4.2 Type 1 test bench

The test bench in [Figure 2](#) allows performance measurements to be taken by engaging the pinion with a drive gear, either the ring gear assembly or suitable alternative. The backlash between the pinion and the drive gear teeth shall be in accordance with the starter motor manufacturer’s recommendations.

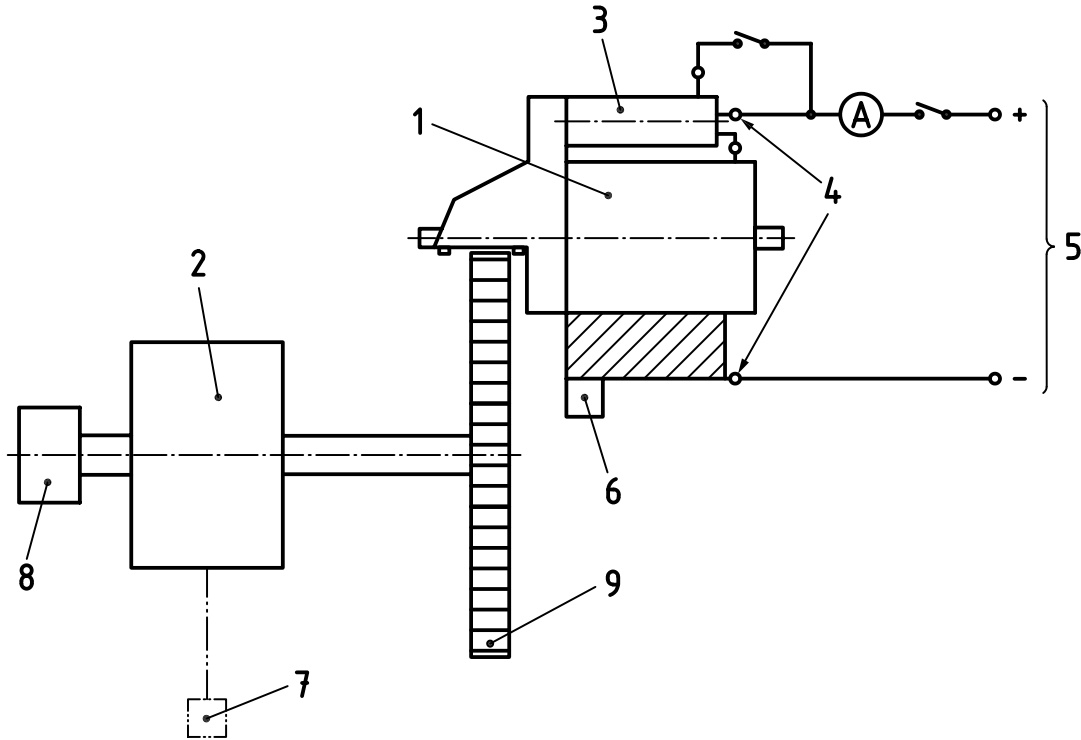

Key

- 1 starter motor
- 2 brake/variable load
- 3 solenoid
- 4 starter motor terminals
- 5 starter motor power supply
- 6, 7 torque measurement
- 8 rotational frequency measurement
- 9 drive gear

Figure 2 — Type 1 test bench

4.3 Type 2 test bench

The test bench in [Figure 3](#) permits direct measurement of the starter motor at the pinion or armature shaft. The starter motor shall be coupled to the test device coaxially through a suitable coupling. The drive end shield of a nose-type starter motor can be replaced by a special bearing bracket to permit coupling to the starter motor shaft.

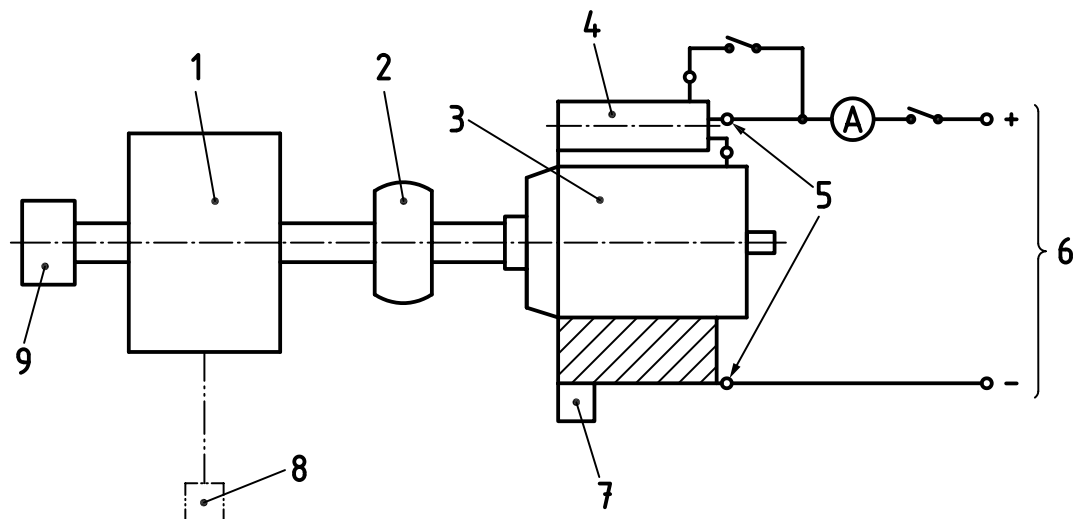

Key

- 1 brake/variable load
- 2 coupling
- 3 starter motor
- 4 solenoid
- 5 starter motor terminals
- 6 starter motor power supply
- 7,8 torque measurement
- 9 rotational frequency measurement

Figure 3 — Type 2 test bench

Table 2 — Voltage/current characteristic of starter motor supply for starter motor testing

Voltage/current characteristic number	Nominal voltage V	Voltage/current characteristic at 20 °C					Suggested nominal power of starter motor kW
		U_1 V	I_1 A	U_2 V	I_2 A	R_{BL} mΩ	
1	12	12	0	6	400	15	$P_{nom} \leq 1,7$
2					600	10	$1 < P_{nom} \leq 2,5$
3					800	7,5	$1,5 < P_{nom} \leq 3,4$
4					1 000	6	$1,5 < P_{nom} \leq 4,2$
5					1 200	5	$2,5 < P_{nom} \leq 5$
6					1 500	4	$3 < P_{nom} \leq 6,3$
7					2 000	3	$3,8 < P_{nom} \leq 8,4$
8					3 000	2	$P_{nom} > 5$
9	24	24	0	12	600	20	$P_{nom} \leq 5$
10					800	15	$3 < P_{nom} \leq 6,7$
11					1 000	12	$4 < P_{nom} \leq 8,4$
12					1 200	10	$5 < P_{nom} \leq 10$
13					1 500	8	$6 < P_{nom} \leq 12,6$
14					1 700	7,06	$7,5 < P_{nom} \leq 14,3$
15					2 000	6	$8,3 < P_{nom} \leq 16,8$
16					2 400	5	$P_{nom} > 10$

5 Test method

5.1 General

Test method A or B shall be used. Method C can also be used in addition, if required.

If it is important to know the starter motor performance at a temperature of -25 °C , this can be measured according to [5.2.3](#) or it can be calculated by using the values measured in accordance with [5.2.1](#) or [5.2.2](#) and the calculation methods described in [Clause 6](#).

If required, temperatures different from -25 °C can be considered as agreed between the starter motor manufacturer and the engine manufacturer.

5.2 Test procedure

5.2.1 Method A — Continuous mode method

Energize the starter motor and allow it to reach the starting rotational frequency for the test, e.g. near to the no load rotational frequency. Using the brake or variable load, decrease the rotational frequency at a constant rate while torque, current, voltage, and rotational frequency are automatically recorded. The test is finished when a minimum armature speed is reached. This speed is defined by the starter motor manufacturer to avoid damage to the starter motor.

The total test time shall be $\leq 10\text{ s}$.

5.2.2 Method B — Discrete point method

Run the starter motor at discrete torque load, rotational frequency, or current points and record the torque, current, voltage, and rotational frequency at each of these discrete points. The number of points will be determined by the purpose of the test.

The time for each discrete point measurement shall be ≤ 3 s.

After each measurement point, cool all parts of the starter motor to the test temperature (see 3.1.1).

5.2.3 Method C — Continuous mode method at cold cranking temperature

Precondition the starter motor at cold cranking temperature and test it according to 5.2.1. The test shall be completed within 3 min of the starter motor being removed from the preconditioning environment.

The total test time shall be ≤ 10 s.

6 Measurement correction

6.1 General

The measured values of torque and rotational frequency shall be corrected taking into account the influence of the test bench, inertia, and temperature.

The calculations described below are applicable to both permanent magnet starter motors and electrically excited starter motors.

6.2 Correction of torque

6.2.1 General

Torque is measured either directly as the reaction torque of the starter motor, or at the drive gear shaft.

If torque is measured directly, the corrections given in 6.2.3 and 6.2.4 apply. If torque is measured at the drive gear shaft, the corrections given in 6.2.2 to 6.2.4 apply.

6.2.2 Correction of torque with train efficiency

This is only required for test bench type 1 and if torque is measured at the drive gear shaft. The correction shall be made using Formula (1):

$$M_1 = M_m \times \frac{z_1}{z_2 \times \eta_g} \quad (1)$$

where

M_1 is the torque corrected with the gear train efficiency, in Nm;

M_m is the measured torque, in Nm;

z_1 is the number of teeth on the starter motor pinion;

z_2 is the number of teeth on the test bench ring-gear;

η_g is the gear train (pinion to drive gear) efficiency.

6.2.3 Correction of torque with inertia

For test procedures A and C the following correction to account for armature deceleration shall be used:

$$M_2 = M_m - 2\pi \times \frac{\Delta n}{\Delta t} \times (J_{br} + J_a) \quad (2)$$

where

M_2 is the torque corrected for inertia, in Nm;

M_m is the measured torque, in Nm (if 6.2.2 applied, $M_m = M_1$);

Δn is the difference in pinion rotational frequency between two consecutive measurement points, in Hz;

Δt is the time difference between two measurement points, in s;

J_{br} is the moment of inertia of the measuring device, related to the pinion, in $\text{kg} \cdot \text{m}^2$;

J_a is the moment of inertia of armature and other rotating parts, related to the pinion, in $\text{kg} \cdot \text{m}^2$.

6.2.4 Correction of torque with temperature

In the case of permanent magnet starter motors the magnetic flux changes with temperature. The torque corrected as in 6.2.1 or 6.2.2 shall be further corrected in accordance with one of the following formulae.

For test method B:

$$M_3 = M_1 \times [1 + \beta \times (T_2 - T_1)] \quad (3)$$

For test methods A and C:

$$M_3 = M_2 \times [1 + \beta \times (T_2 - T_1)] \quad (4)$$

where

M_3 is the torque corrected with temperature, in Nm;

M_1, M_2 are as defined in Formulae (1) and (2), in Nm;

T_1 is the initial measurement temperature, in $^{\circ}\text{C}$;

T_2 is the target temperature, in $^{\circ}\text{C}$;

B is the magnetic induction coefficient of the permanent magnetic field, in $^{\circ}\text{C}^{-1}$.

The value of β may vary between $-2 \times 10^{-3} \text{ }^{\circ}\text{C}^{-1}$ and $-2,3 \times 10^{-3} \text{ }^{\circ}\text{C}^{-1}$ depending on the material of the permanent magnets. In the case of electrically excited starter motors, $\beta = 0$. The β coefficient has to be constant in the temperature range between T_1 and T_2 to apply Formulae (3) and (4).

6.3 Correction of rotational frequency with temperature

The rotational frequency, n , is given by Formula (5):

$$n = k \times \frac{U_i}{\Phi} \quad (5)$$

where

k is the motor constant of starter motor;

U_i is the induced voltage, in V;

Φ is the magnetic flux in the air gap of starter motor, in Wb.

The rotational frequency change is generally calculated considering Formula (6):

$$U_i = U - R \times I - U_{br} \quad (6)$$

where

U is the applied voltage, in V;

U_{br} is the voltage drop across the brush commutator system, in V;

R is the resistance of the copper parts of the starter motor, in Ω ;

I is the starter motor current, in A.

For a temperature change from T_1 to T_2 , the starter motor internal resistance changes from R_1 to R_2 according to Formula (7):

$$R_2 = [1 + \alpha \times (T_2 - T_1)] \times R_1 \quad (7)$$

where

α is the temperature coefficient of the resistance for the starter motor winding material.

The value for α for copper (100 %) as specified in the International Annealed Copper Standard (IACS) is $(3,93 \times 10^{-3}) \text{ }^\circ\text{C}^{-1}$ at 20 $^\circ\text{C}$. For starter motors using composite copper/aluminium windings, α has to be calculated specifically. The coefficient has to be constant in the temperature range between T_1 and T_2 to apply Formula (7).

In the case of a permanent magnet starter motor, the magnetic flux changes with the temperature.

The rotational frequency change from n_1 to n_2 is calculated using Formula (8):

$$n_2 = \frac{U_{i2}}{U_{i1}} \times \frac{1}{1 + \beta \times (T_2 - T_1)} \times n_1 \quad (8)$$

where U_{i1} and U_{i2} are calculated using Formula (6) and T_1 , T_2 , and β are as specified in [6.2.4](#).

7 Presentation of results

7.1 Power output and efficiency calculation

Starter motor power output P , in W, is calculated using Formula (9):

$$P = 2\pi \times \frac{n}{60} \times M \quad (9)$$

where

M is the torque, in Nm (M_3);

n is the rotational frequency, in min^{-1} .

Starter motor efficiency is:

$$\eta = \frac{P}{U \times I} \quad (10)$$

7.2 Graphic presentation of starter motor characteristic curves

Performance characteristics shall be presented in accordance with [Figure 4](#). If necessary, the measured parameters shall be corrected to the reference temperature [see Formula (7)] and the test bench used shall be stated.

If so required, the starter motor performance can be presented as a rotational frequency/torque characteristic.

If the test temperature is different from the reference temperature, then this shall be stated in the test report.

If requested, the efficiency can also be shown.

If torque is measured at the drive gear shaft, the efficiency of gear train shall be stated in the test report.

If a temperature correction was done, the voltage drop U_{br} used shall be stated in the test report.

7.3 Change of voltage/current characteristic

For changes in applied voltage, the value U in Formula (6) is affected and the rotational frequency is calculated using Formula (8). The power output characteristic is calculated as in [7.1](#).

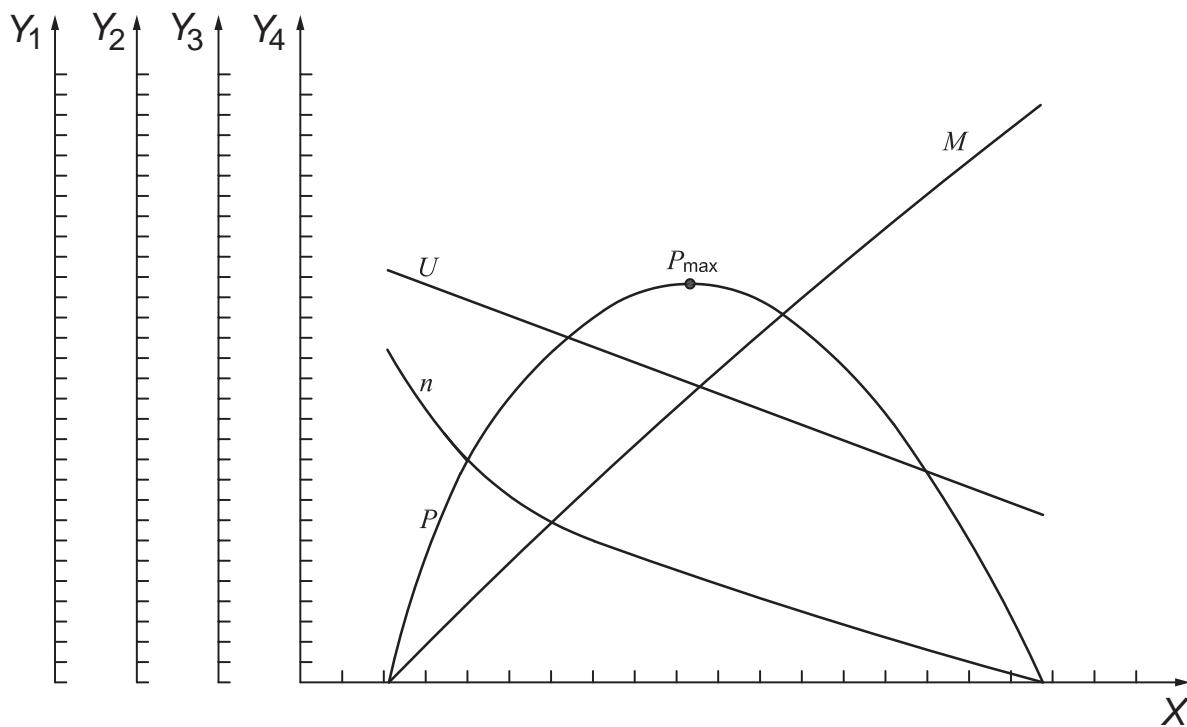

Key

- Y_1 starter rotational frequency, n (rpm)
- Y_2 torque, M (Nm)
- Y_3 output power, P (kW)
- Y_4 voltage starter terminals, U (V)
- X starter current, I (A)

Figure 4 — Presentation of results

