

# INTERNATIONAL STANDARD

**ISO  
8811**

First edition  
2000-08-01

---

## **Earth-moving machinery — Rollers and compactors — Terminology and commercial specifications**

*Engins de terrassement — Engins de compactage — Terminologie et  
spécifications commerciales*

This material is reproduced from ISO documents under International Organization for Standardization (ISO) Copyright License Number IHS/CC/1996. Not for resale. No part of these ISO documents may be reproduced in any form, electronic retrieval system or otherwise, except as allowed in the copyright law of the country of use, or with the prior written consent of ISO (Case postale 56, 1211 Geneva 20, Switzerland, Fax +41 22 734 10 79), IHS or the ISO Licensor's members.



Reference number  
ISO 8811:2000(E)

© ISO 2000

**PDF disclaimer**

This PDF file may contain embedded typefaces. In accordance with Adobe's licensing policy, this file may be printed or viewed but shall not be edited unless the typefaces which are embedded are licensed to and installed on the computer performing the editing. In downloading this file, parties accept therein the responsibility of not infringing Adobe's licensing policy. The ISO Central Secretariat accepts no liability in this area.

Adobe is a trademark of Adobe Systems Incorporated.

Details of the software products used to create this PDF file can be found in the General Info relative to the file; the PDF-creation parameters were optimized for printing. Every care has been taken to ensure that the file is suitable for use by ISO member bodies. In the unlikely event that a problem relating to it is found, please inform the Central Secretariat at the address given below.

© ISO 2000

All rights reserved. Unless otherwise specified, no part of this publication may be reproduced or utilized in any form or by any means, electronic or mechanical, including photocopying and microfilm, without permission in writing from either ISO at the address below or ISO's member body in the country of the requester.

ISO copyright office  
Case postale 56 • CH-1211 Geneva 20  
Tel. + 41 22 749 01 11  
Fax + 41 22 749 09 47  
E-mail [copyright@iso.ch](mailto:copyright@iso.ch)  
Web [www.iso.ch](http://www.iso.ch)

Printed in Switzerland

**Contents**

Page

<b>Foreword</b> .....	<b>iv</b>
<b>1 Scope</b> .....	<b>1</b>
<b>2 Normative references</b> .....	<b>1</b>
<b>3 Terms and definitions</b> .....	<b>1</b>
<b>4 Base-machine types</b> .....	<b>4</b>
<b>5 Nomenclature</b> .....	<b>7</b>
<b>6 Dimensions</b> .....	<b>11</b>
<b>7 Engine net power</b> .....	<b>17</b>
<b>8 Maximum travelling speeds</b> .....	<b>17</b>
<b>9 Maximum permitted inclination angle</b> .....	<b>18</b>
<b>10 Gradeability</b> .....	<b>18</b>
<b>11 Commercial literature specifications</b> .....	<b>18</b>

## Foreword

ISO (the International Organization for Standardization) is a worldwide federation of national standards bodies (ISO member bodies). The work of preparing International Standards is normally carried out through ISO technical committees. Each member body interested in a subject for which a technical committee has been established has the right to be represented on that committee. International organizations, governmental and non-governmental, in liaison with ISO, also take part in the work. ISO collaborates closely with the International Electrotechnical Commission (IEC) on all matters of electrotechnical standardization.

International Standards are drafted in accordance with the rules given in the ISO/IEC Directives, Part 3.

Draft International Standards adopted by the technical committees are circulated to the member bodies for voting. Publication as an International Standard requires approval by at least 75 % of the member bodies casting a vote.

Attention is drawn to the possibility that some of the elements of this International Standard may be the subject of patent rights. ISO shall not be held responsible for identifying any or all such patent rights.

International Standard ISO 8811 was prepared by Technical Committee ISO/TC 127, *Earth-moving machinery*, Subcommittee SC 4, *Commercial nomenclature, classification and rating*.

# Earth-moving machinery — Rollers and compactors — Terminology and commercial specifications

## 1 Scope

This International Standard defines the terms used to describe, and the commercial specification of, rollers and compactors, their equipment and attachments. It identifies the different types of machines, in addition to their nomenclature, and the symbols used to indicate their dimensions and those of their attachments. Self-propelled, towed, walk-behind (pedestrian) and attachment-type-compactors machines are covered.

## 2 Normative references

The following normative documents contain provisions which, through reference in this text, constitute provisions of this International Standard. For dated references, subsequent amendments to, or revisions of, any of these publications do not apply. However, parties to agreements based on this International Standard are encouraged to investigate the possibility of applying the most recent editions of the normative documents indicated below. For undated references, the latest edition of the normative document referred to applies. Members of ISO and IEC maintain registers of currently valid International Standards.

ISO 6014:1986, *Earth-moving machinery — Determination of ground speed.*

ISO 6016:1998, *Earth-moving machinery — Methods of measuring the masses of whole machines, their equipment and components.*

ISO 6746-1:—<sup>1)</sup>, *Earth-moving machinery — Definitions of dimensions and symbols — Part 1: Base machine.*

ISO 6746-2:—<sup>2)</sup>, *Earth-moving machinery — Definitions of dimensions and symbols — Part 2: Equipment.*

ISO 9249:1997, *Earth-moving machinery — Engine test code — Net power.*

## 3 Terms and definitions

For the purposes of this International Standard, the following terms and definitions apply.

### 3.1 General

#### 3.1.1

##### **landfill compactor**

self-propelled compaction machine having front-mounted equipment or attachments for dozing or loading, whose wheels are able to crush and compact waste material, and which can move, grade and load soil, landfill or refuse

---

1) To be published. (Revision of ISO 6746-1:1987)

2) To be published. (Revision of ISO 6746-2:1987)

**ISO 8811:2000(E)****3.1.2****roller**

self-propelled or towed machine having one or more metallic cylindrical bodies (drums) or rubber tyres whose rolling or vibrating action, or both, it uses to compact materials such as crushed rock, earth, asphalt or gravel

**3.1.3****towed roller**

non-self-propelled **roller** (3.1.2) propelled by a towing machine; the operator's station is located on the towing unit

**3.1.4****base machine**

machine, which may include a cab, canopy, ROPS<sup>3)</sup>, FOPS<sup>4)</sup> or both, having mountings for equipment or attachments, as described by the manufacturer's specifications

**3.1.5****equipment**

set of components mounted onto the base machine to fulfil the primary design function when an attachment is fitted

**3.1.6****attachment**

optional assembly of components that can be mounted onto the base machine or its equipment for a specific use

NOTE Adapted from ISO 6016.

**3.1.7****component**

part, or assembly of parts, of base machine, equipment or attachment

NOTE Adapted from ISO 6016.

**3.1.8****counterweight**

any additional removable weight and its removable support added to increase tipping load

**3.2 Masses and vibration****3.2.1****operating mass**

mass of the base machine with equipment and attachment as specified by the manufacturer, with operator (75 kg), full fuel tank and all fluid systems at the levels specified by the manufacturer

NOTE Adapted from ISO 6016.

**3.2.2****shipping mass**

mass of the base machine without operator, with fuel level at 10 % of tank capacity, all fluid systems at their levels specified by the manufacturer and with or without equipment, attachment, cab, canopy, ROPS, FOPS, wheels and counterweights as stated by the manufacturer

NOTE Adapted from ISO 6016.

---

3) ROPS: Roll-over protective structure.

4) FOPS: Falling object protective structure.

**3.2.3****cab, canopy, ROPS and/or FOPS mass**

mass of a cab, canopy, ROPS or FOPS with all components and mountings for securing the components to the base machine

NOTE If the machine has to be disassembled for shipping purposes, the masses of dismantled components should be stated by the manufacturer.

**3.2.4****mass of vibrated parts**

mass of vibrating drum together with mass of all other parts rigidly connected to it

**3.2.5****mass of isolated parts**

mass of all parts supported by the vibrating drum (bottom plate) isolated from vibration

**3.2.6****frequency**

number of cycles per minute (r/min, v/min) divided by 60

NOTE The frequency is expressed in hertz (Hz).

**3.2.7****eccentric moment**

product of the eccentric force and its radius of eccentricity

NOTE The eccentric moment is expressed in newton metres (N·m).

**3.2.8****centrifugal force**

product of the eccentric force and the square of the angular rotating velocity

NOTE The centrifugal force is expressed in newtons (N).

**3.2.9****nominal amplitude**

**eccentric moment** (3.2.7) divided by the vibrated mass

NOTE The nominal amplitude is expressed in millimetres.

**3.3 Linear load and surface pressure****3.3.1****linear load**

(smooth drums) total load exerted on the ground by the drum, with or without ballast, divided by the drum's rolling width

NOTE The linear load is expressed in kilograms per centimetre.

**3.3.2****surface pressure**

(padfoot and sheep-foot drums) total load exerted on the ground by the drum, with or without ballast, divided by the total contact area of the minimum number of feet simultaneously in contact with level ground

**3.3.3****theoretical surface pressure**

(pneumatic tyres) ratio of the machine load, with or without ballast, and the total contact area measured on an even, hard surface

## ISO 8811:2000(E)

NOTE Values can be shown in a diagram as the relation between the theoretical surface pressure and the wheel load, tyre-inflation pressure and contact area.

## 4 Base-machine types

### 4.1 Direction and location

The directional and locational references, right or left, front or rear, shall be used in relation to the position of the operator at the controls of the base machine, and the principal direction of travel, according to the manufacturer.

### 4.2 Self-propelled and towed, pedestrian, static or dynamic machines

4.2.1 Static single-drum roller (see Figure 1).

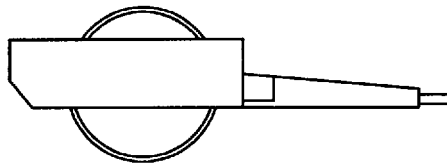

Figure 1 — Static single-drum roller

4.2.2 Dynamic single-drum roller (see Figure 2).

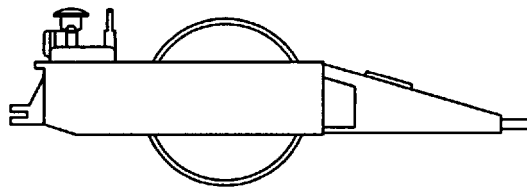

Figure 2 — Dynamic single-drum roller

4.2.3 Static single-drum roller (see Figure 3).

4.2.4 Dynamic single-drum roller (see Figure 3).

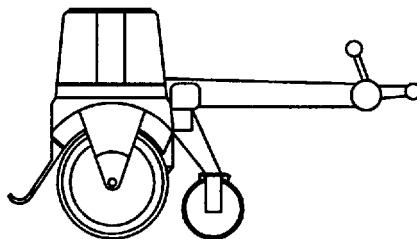

Figure 3 — Static or dynamic single-drum roller



4.2.5 Dynamic dual-drum (duplex) roller (see Figure 4).

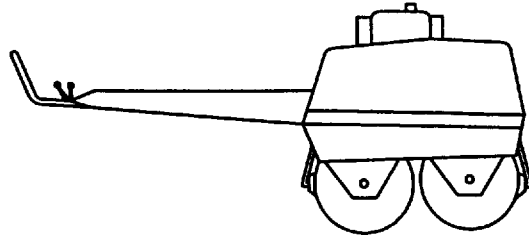

Figure 4 — Dynamic dual-drum roller

4.2.6 Trench roller (see Figure 5).

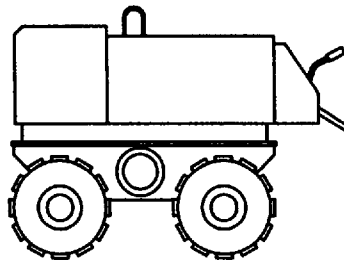

Figure 5 — Trench roller

4.3 Ride-on, self-propelled machines

4.3.1 Static dual-drum roller with rigid frame and yoke-mounted steering drum, front or rear (see Figure 6).

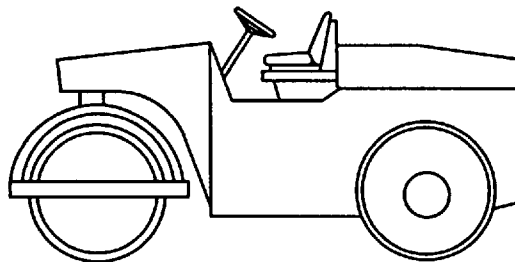

Figure 6 — Static dual- or three-drum roller with rigid frame and yoke-mounted steering drum

4.3.2 Static dual- or four-drum roller with articulated steering (see Figure 7).

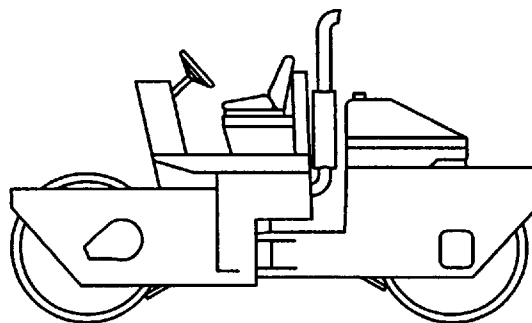

Figure 7 — Static or dynamic, dual- or four-drum roller with articulated steering

## ISO 8811:2000(E)

4.3.3 Static three-drum roller with rigid frame and yoke-mounted steering drum, front or rear (see Figure 6).

4.3.4 Static three-drum roller with articulated steering (see Figure 8).

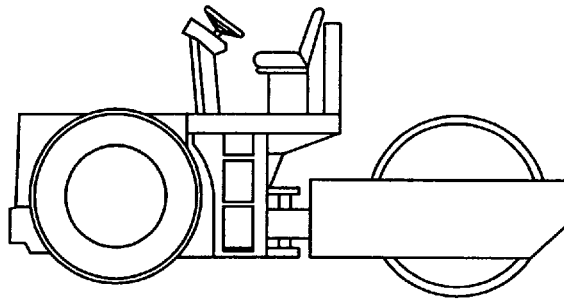

Figure 8 — Static or dynamic three-drum roller with articulated steering

4.3.5 Static four-drum roller with rigid frame and skid steering (not shown).

4.3.6 Pneumatic-tyred roller with rigid frame and yoke-mounted steering, front or rear (see Figure 9).

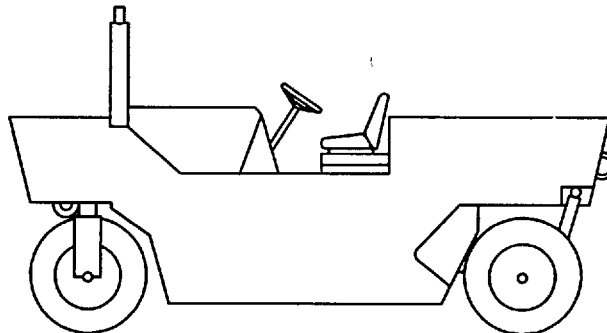

Figure 9 — Pneumatic-tyre roller with rigid frame and yoke-mounted steering

4.3.7 Pneumatic-tyred roller with articulated steering (not shown).

4.3.8 Dynamic dual-drum roller with rigid frame and yoke-mounted steering drum, front or rear (not shown).

4.3.9 Dynamic dual-drum roller with pivot-articulated steering and one or two dynamic drums (not shown).

4.3.10 Dynamic three-drum roller with rigid frame and yoke-mounted steering drum, front or rear (see Figure 6).

4.3.11 Dynamic three-drum roller with articulated steering (see Figure 8).

4.3.12 Dynamic four-drum roller with articulated steering (see Figure 7).

4.3.13 Dynamic single-drum, dual-wheel roller with pivot-articulated steering (see Figure 10).

NOTE This type of machine can also possess drum drive.

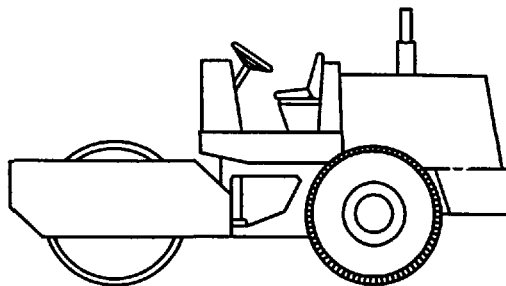

**Figure 10 — Dynamic single-drum, dual-wheel roller with pivot-articulated steering**

**4.3.14** Static or dynamic dual-drum roller with crab-steering or drum-offset-steering hitch (see Figure 11).

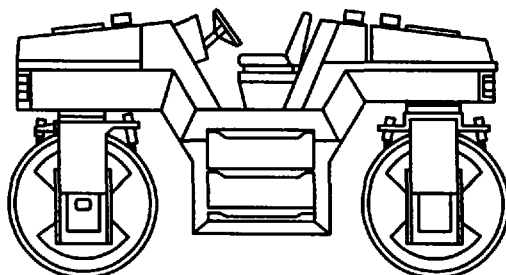

**Figure 11 — Static or dynamic dual-drum roller with crab-steering or drum-offset-steering hitch**

**4.3.15** Combined roller with dynamic drum and pneumatic tyres, fitted in pivot-articulated frame (not shown).

**4.3.16** Three-drum roller with rigid frame and two yoke-mounted, in-line steering drums (not shown).

**4.3.17** Combined roller with dynamic drum and yoke mounted pneumatic tyres (not shown).

## **5 Nomenclature**

### **5.1 Towed and self-propelled, pedestrian, static or dynamic base machines**

**5.1.1** See Figure 12 a), in relation to 4.2.1 and 4.2.2.

**5.1.2** See Figure 12 b), in relation to 4.2.5.

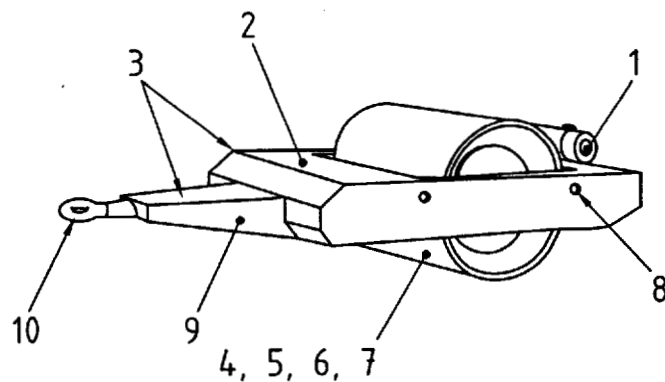

a) Static or dynamic single-drum roller

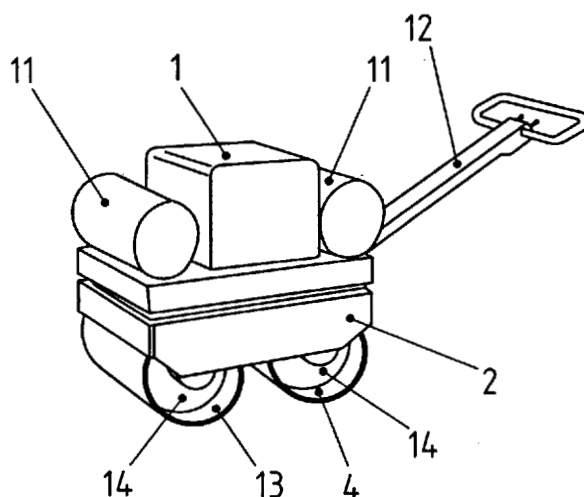

b) Dynamic dual-drum (duplex) roller

**Key**

1	Engine	8	Lifting eye
2	Frame	9	Towing bar
3	Ballast	10	Towing eye
4	Drum, vibrating	11	Water tank
5	Sheepfoot (drum)	12	Steering pole/handle
6	Padfoot (drum)	13	Drum, driving
7	Grid (drum)	14	Drum drive/drive

**Figure 12 — Base machines, towed and self-propelled**

**5.2 Ride-on, self-propelled base machines**

5.2.1 See 4.3.1 and 4.3.8 in respect of Figure 13 a).

5.2.2 See 4.3.5 and 4.3.13 in respect of Figure 13 b).

5.2.3 See 4.3.13 in respect of Figure 13 c).

5.2.4 See 4.3.6 and 4.3.7 in respect of Figure 13 d).

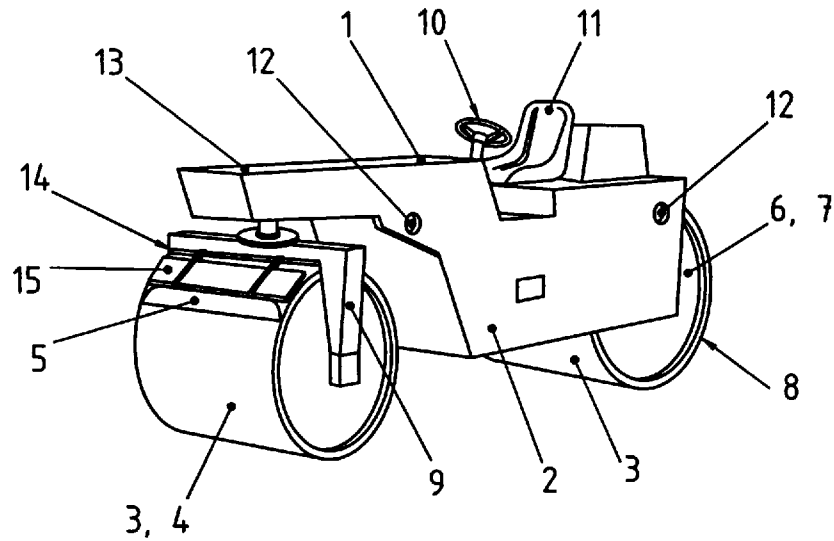

a) Static or dynamic dual-drum roller

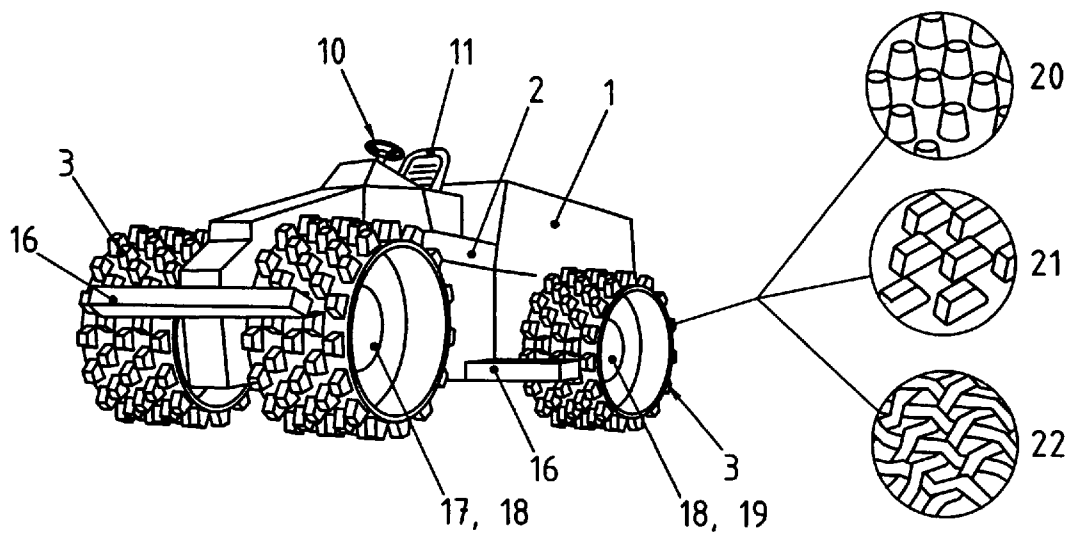

b) Dynamic four-drum, or single-drum dual-wheel roller

**Key**

1	Engine	8	Drum, vibrating	15	Mat	22	Grid (drum)
2	Frame	9	Steering yoke	16	Scraper bar		
3	Drum, driving	10	Steering wheel	17	Axle, front		
4	Drum, steering plate	11	Operator's seat	18	Drive axle		
5	Scraper	12	Lifting eye	19	Axle, rear		
6	Drum	13	Water tank	20	Sheepfoot (drum)		
7	Drum drive/drive	14	Sprinkler tube	21	Padfoot (drum)		

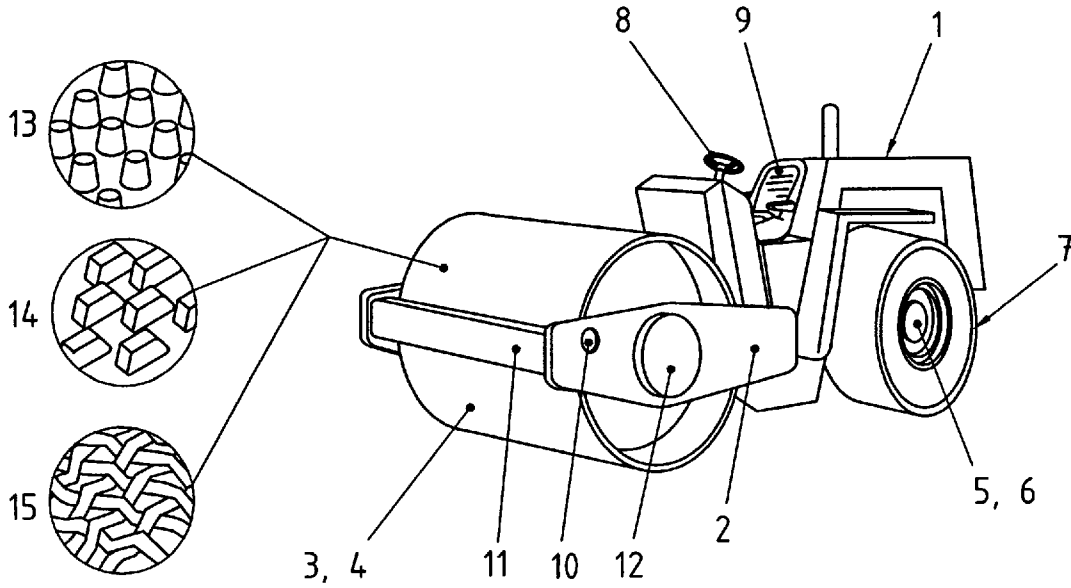

c) Dynamic single-drum, dual-wheel roller

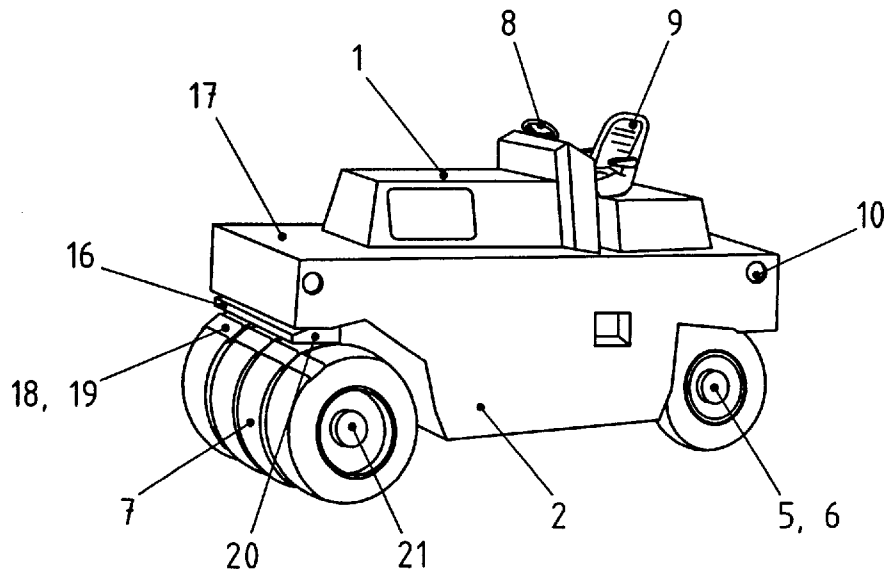

d) Pneumatic-tyred roller

**Key**

1 Engine	8 Steering wheel	15 Grid (drum)
2 Frame	9 Operator's seat	16 Sprinkler tube
3 Drum, driving	10 Lifting eye	17 Water tank
4 Drum, vibrating	11 Scraper bar	18 Scraper
5 Axle, rear	12 Drum drive/drive	19 Mat
6 Drive axle	13 Sheepfoot (drum)	20 Steering yoke
7 Tyre	14 Padfoot (drum)	21 Axle, front

**Figure 13 — Base machines, ride-on self-propelled**

## 6 Dimensions

### 6.1 Base machines

6.1.1 For definitions and symbols of dimensions strictly related to rollers and compactors, those presented in Table 1 apply. For 6.1.2 to 6.1.4, and Figure 14 to Figure 16, ISO 6746-1 applies.

6.1.2 See Figure 14, in relation to 4.3.1 and 4.3.8.

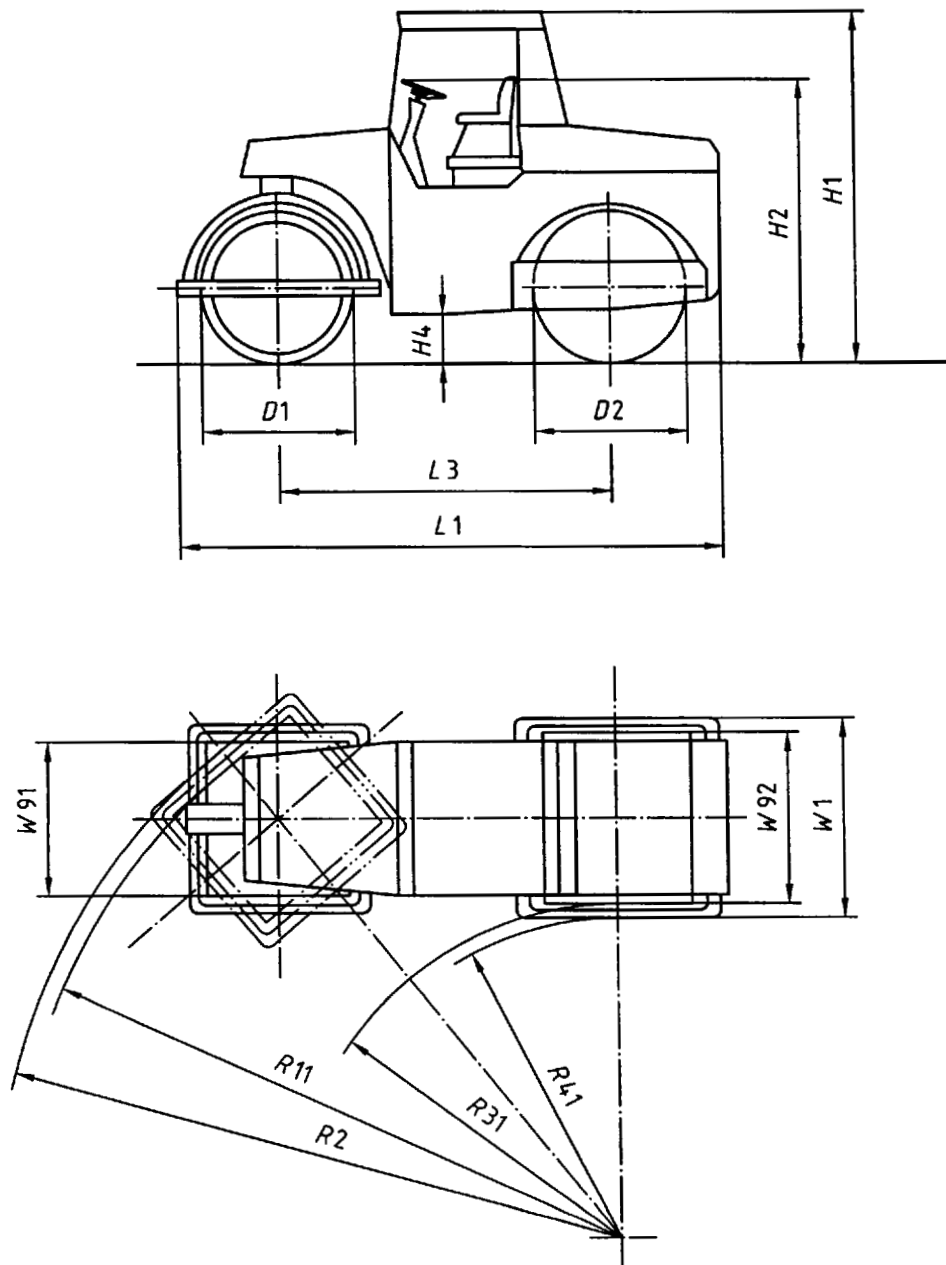

Figure 14 — Static or dynamic dual-drum roller with rigid frame and yoke-mounted steering drum, front or rear

ISO 8811:2000(E)

6.1.3 See 4.3.3 and 4.3.10 in respect of Figure 15.

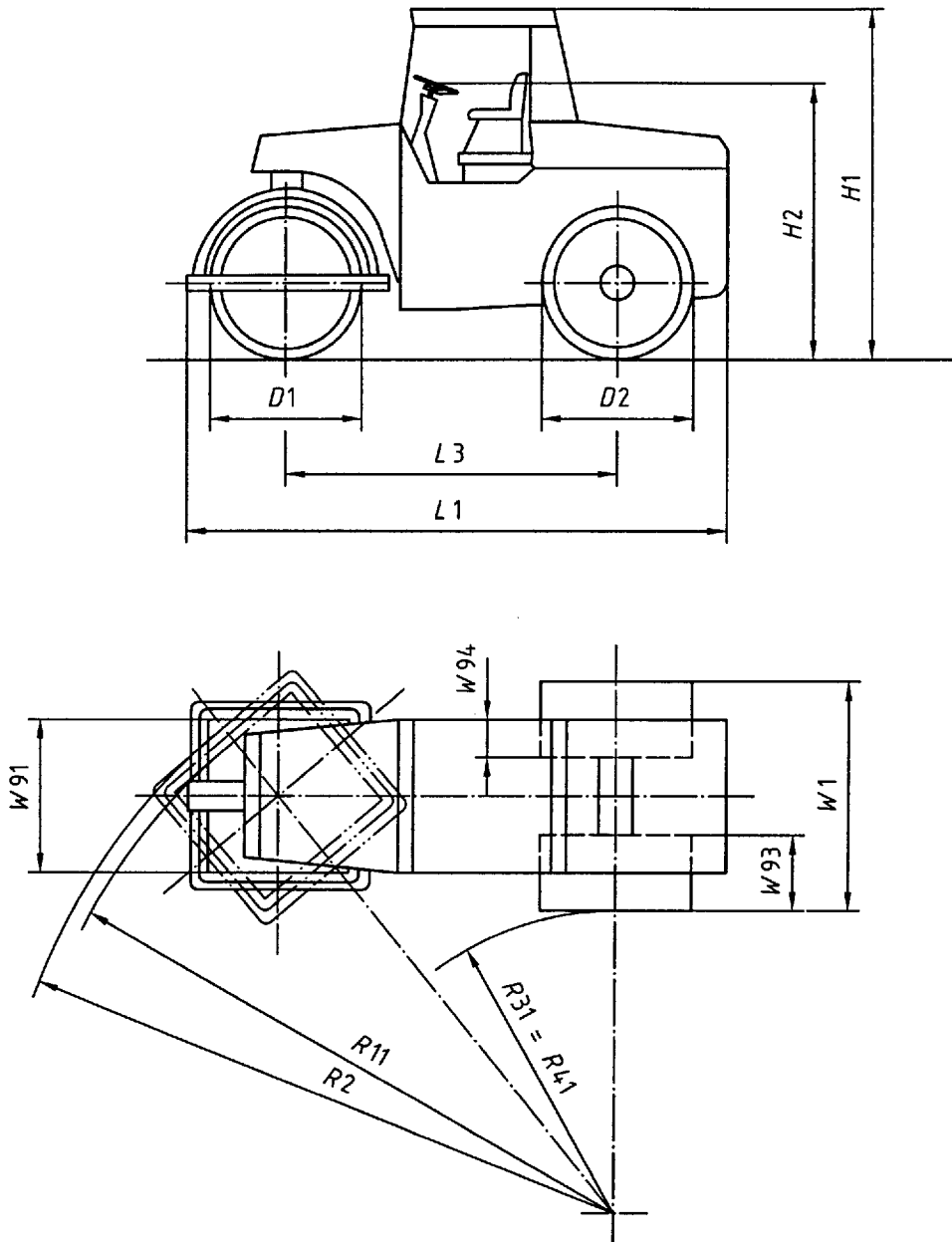

Figure 15 — Static or dynamic three-drum roller with rigid frame and yoke-mounted steering drum, front or rear



6.1.4 See 4.3.13 in respect of Figure 16.

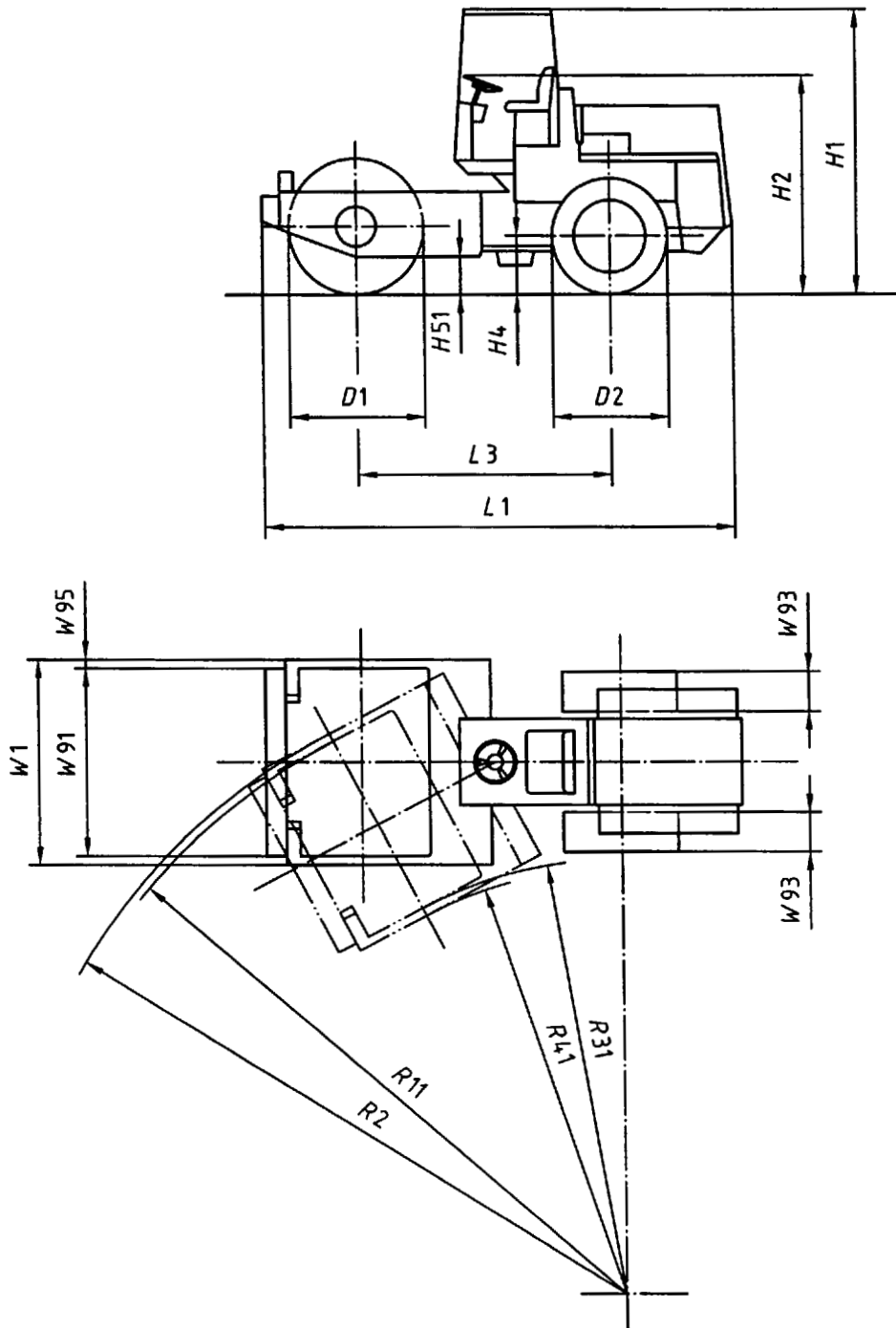

Figure 16 — Dynamic single-drum, dual-wheel roller with pivot-articulated steering

Table 1 — Base-machine dimensions, their symbols and definitions

Symbol	Term	Definition	Drawing
D1	Front-drum diameter	Distance on X coordinate between the outer surface of the front drum through the centre of the drum.	
D2	Rear-drum diameter	Distance on X coordinate between the outer surface of the rear drum through the centre of the drum.	
H51	Kerb clearance	Distance on Z coordinate between the ground reference plane (GRP) and the lowest chassis part on the outside of the drum.	
W91	Front-drum width	Distance on Y coordinate between two Y planes passing through the farthest point on the sides of the bare front drum.	
W92	Rear-drum width	Distance on Y coordinate between two Y planes passing through the farthest point on the sides of the rear drum.	

Table 1 (continued)

Symbol	Term	Definition	Drawing
W93	Rear-drum width (twin drums)	Distance on Y coordinate between two Y planes passing through the farthest point on the bare rear drums.	
W94	Drum overlap (each side)	Distance on Y coordinate between two planes one of which is passing through the outer side of the front drum and the other through the inner side of the rear drum on rollers with rear twin drums.	
W95	Side clearance or lateral overhang	Distance on Y coordinate between two planes passing through the outer side of the drum and the farthest point of the machine.	
R11	Turning radius outside compacted surface	Distance on Y coordinate (Z plane) between the turning centre and the outside plane of the front roller while the machine is executing its smallest practical turn.	

Table 1 (continued)

Symbol	Term	Definition	Drawing
R31	Turning radius inside compacted surface	Distance on Y coordinate (Z plane) between the turning centre and the inside plane of the front roller while the machine is executing its smallest practical turn.	
R41	Machine clearance radius inside	Distance on Y coordinate (Z plane) between the turning centre and the outmost points of the machine and its equipment when it executes its smallest practical turn.	
$\alpha$	Tilting between frame parts	Possible movement in the X plane ( $\pm$ ).	

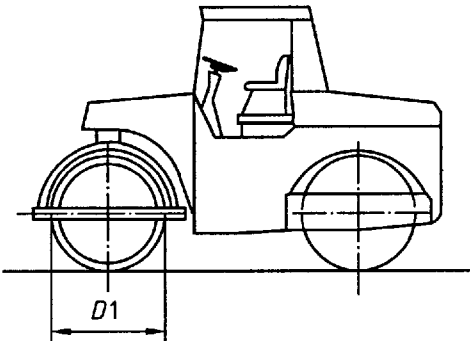
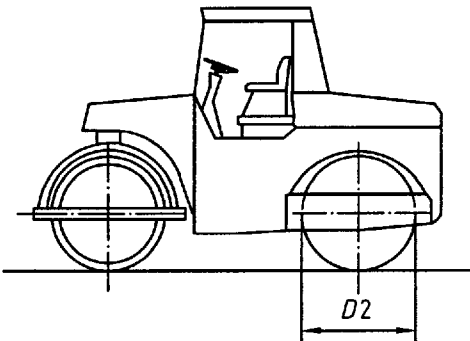
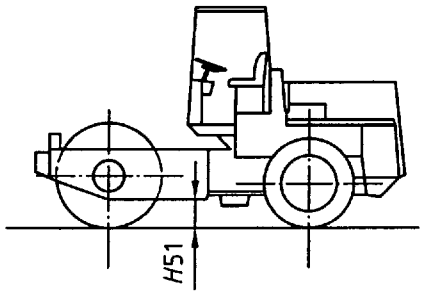
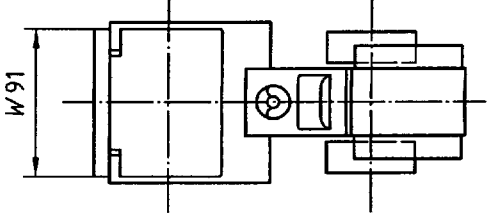
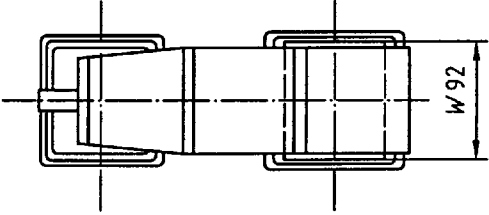
## 6.2 Attachments

6.2.1 For dimension definitions and symbols in Figure 17 and Figure 18, ISO 6746-2 applies.

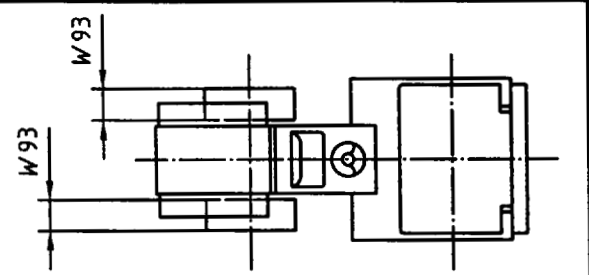
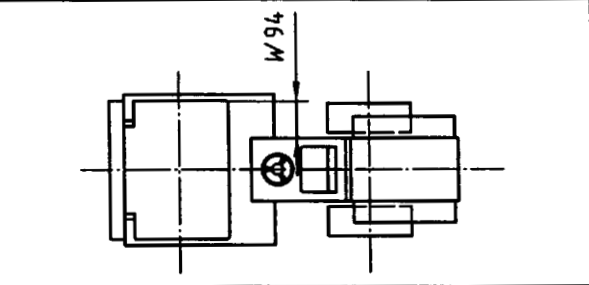
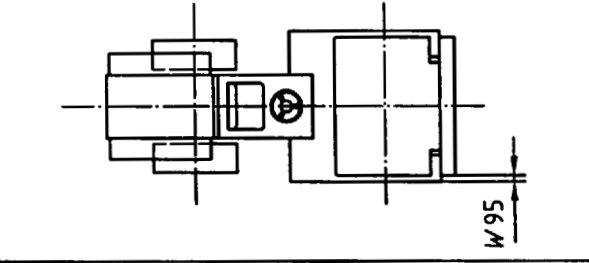
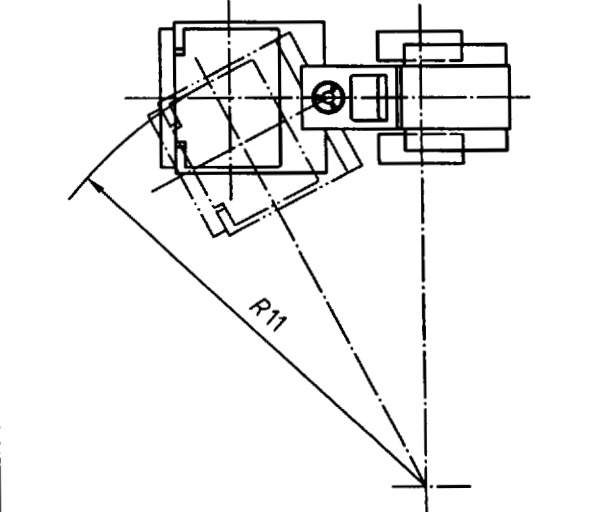
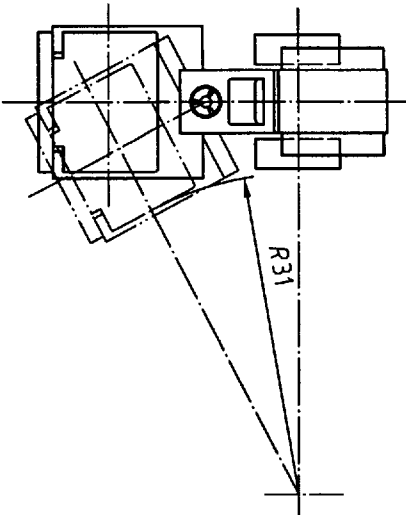
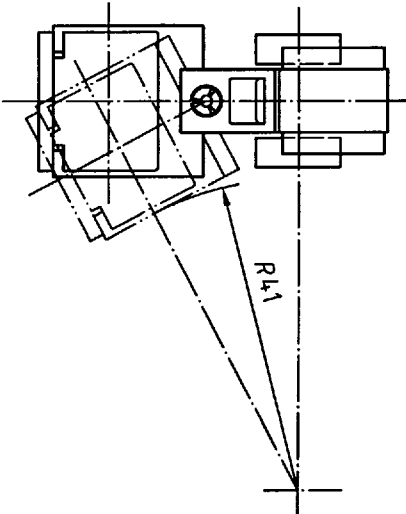
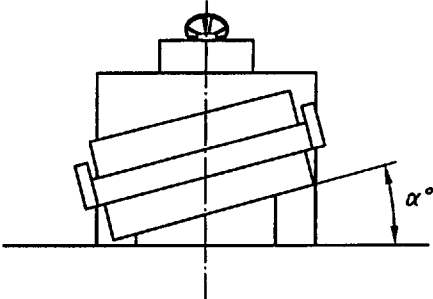
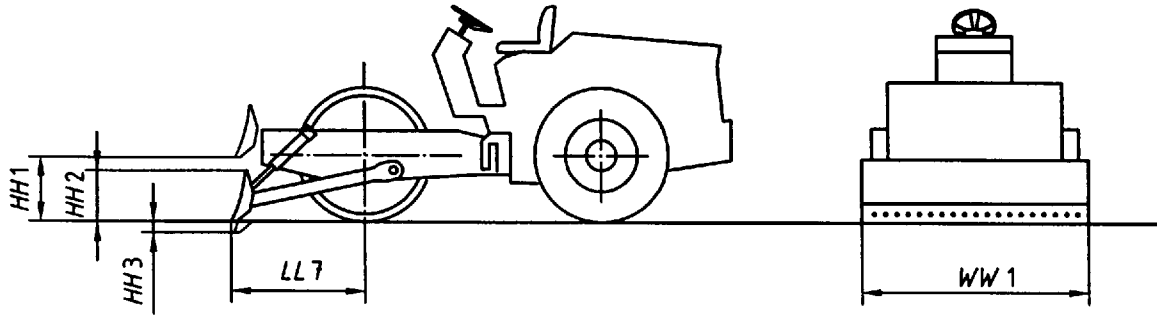

Figure 17 — Strike-off blade

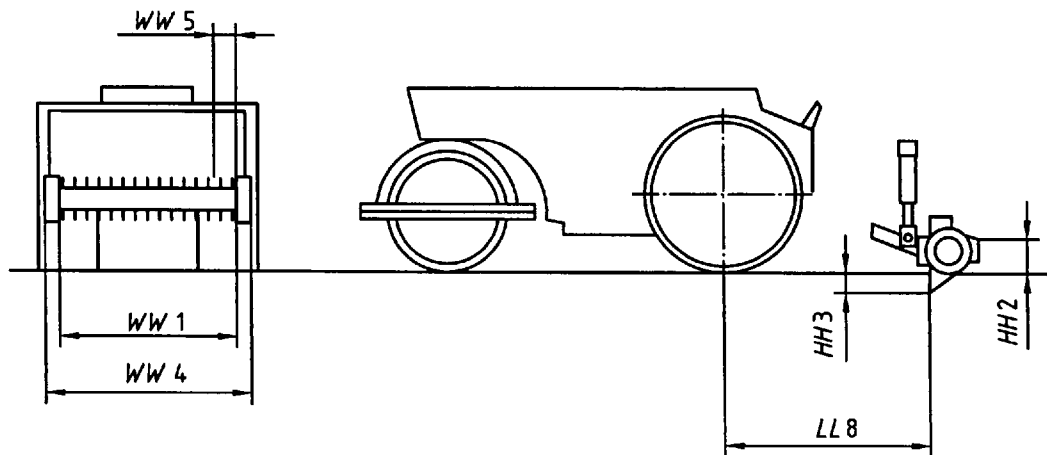

Figure 18 — Scarifier

6.2.2 For definitions and symbols of dimensions strictly related to roller and compactors, those presented in Table 2 apply.

## 7 Engine net power

Refer to ISO 9249.

## 8 Maximum travelling speeds

All speeds shall be determined on a hard level surface (see ISO 6014).

### 8.1 Rollers

Maximum speeds shall be stated at the operating mass, without ballast and with maximum ballast, and for all forward- and reverse-gear combinations.

Table 2 — Attachment dimensions and their symbols

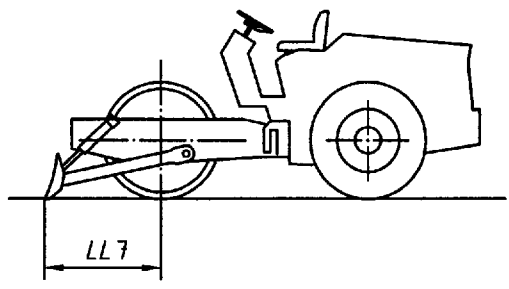
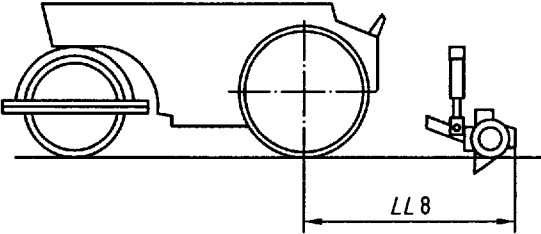
Symbol	Term	Definition	Drawing
LL7	Front overhang	Distance on X coordinate between two X planes passing through the centres of the front wheels and the front extreme point of attachment when the attachment is resting on the ground reference plane (GRP).	
LL8	Rear overhang	Distance on X coordinate between two X planes.	

## 8.2 Vibratory rammers and plate compactors

Speed shall be stated at maximum engine speed and at the highest gear setting.

## 9 Maximum permitted inclination angle

Inclination angles are those at which the machine is able to be used (longitudinally and transversely) while maintaining its designed functioning capability. The inclination angles should be measured with the machine parked on an even, hard surface. The angles of inclination shall be reported for actual steering angles and with references to the right or left, front or rear, of the machine (see 4.1).

## 10 Gradeability

The maximum gradeability shall be the highest slope angle at which the machine is able to start and travel at constant speed under its own power.

The maximum gradeability of the machine should be established on firm, hard and even subsoil, in forward and reverse drive, with occasional stops. The slipping limits of the drums, tyres, etc., shall be regarded as the actual gradeability. The coefficient of the obtained rolling capability (RC) shall be stated.

## 11 Commercial literature specifications

### 11.1 General

The following information shall be specified in commercial literature.

## 11.2 Mass and loads

The following information shall be compiled according to machine type:

- a) operating mass (with all options);
- b) axle load drum;
- c) axle load drum, rear;
- d) axle load wheel;
- e) static linear load, front;
- f) static linear load, rear;
- g) wheel load.

## 11.3 Dimensions

The following information shall be specified for the machine's dimensions:

- a) working width, front;
- b) working width, rear;
- c) total width;
- d) total length;
- e) total height.

## 11.4 Driving characteristics

The following information shall be specified in respect of the machine's driving characteristics:

- a) driving speed, forward;
- b) driving speed, reverse;
- c) maximum outside turning radius;
- d) maximum gradeability without vibration;
- e) maximum gradeability with vibration;
- f) steering angle;
- g) oscillating angle.

## 11.5 Vibration system

The following information shall be specified for the vibration system:

- a) frequency;
- b) amplitude;
- c) centrifugal force.

**ISO 8811:2000(E)****11.6 Drum and/or tyres**

The following information shall be specified for the drums or tyres or both:

- a) smooth drum;
- b) padfoot drum;
- c) drum width;
- d) drum diameter;
- e) number of padfeet;
- f) shell thickness;
- g) tyre size.

**11.7 Drive system****11.7.1 Engine**

The following information shall be specified for the engine:

- a) manufacturer;
- b) model;
- c) fuel type;
- d) cooling;
- e) performance (according to ISO 9249);
- f) number of cylinders;
- g) bore;
- h) stroke;
- i) electrical system.

**11.7.2 Transmission**

The following information shall be specified for the transmission, as applicable:

- a) manual shift with or without centrifugal clutch;
- b) power shift with torque converter (hydrodynamic);
- c) hydrostatic;
- d) electric;
- e) number of speeds, forward and reverse.



### 11.8 Brake system

The types of service and parking brake shall be specified.

### 11.9 Fluid capacities

The following information shall be specified for the fluid capacities:

- a) fuel;
- b) water (for sprinkler system);
- c) cooling water;
- d) hydraulic;
- e) final drive;
- f) motor oil;
- g) transmission.

**ISO 8811:2000(E)**

---

---

**ICS 01.040.53**

Price based on 21 pages

© ISO 2000 – All rights reserved