

INTERNATIONAL STANDARD

ISO 8795

Third edition
2001-03-01

Plastics piping systems for the transport of water intended for human consumption — Migration assessment — Determination of migration values of plastics pipes and fittings and their joints

*Systèmes de canalisations plastiques pour le transport d'eau destinée à la
consommation humaine — Évaluation de la migration — Détermination des
valeurs de migration des tubes et raccords plastiques et de leurs
assemblages*



Reference number
ISO 8795:2001(E)

© ISO 2001

PDF disclaimer

This PDF file may contain embedded typefaces. In accordance with Adobe's licensing policy, this file may be printed or viewed but shall not be edited unless the typefaces which are embedded are licensed to and installed on the computer performing the editing. In downloading this file, parties accept therein the responsibility of not infringing Adobe's licensing policy. The ISO Central Secretariat accepts no liability in this area.

Adobe is a trademark of Adobe Systems Incorporated.

Details of the software products used to create this PDF file can be found in the General Info relative to the file; the PDF-creation parameters were optimized for printing. Every care has been taken to ensure that the file is suitable for use by ISO member bodies. In the unlikely event that a problem relating to it is found, please inform the Central Secretariat at the address given below.

© ISO 2001

All rights reserved. Unless otherwise specified, no part of this publication may be reproduced or utilized in any form or by any means, electronic or mechanical, including photocopying and microfilm, without permission in writing from either ISO at the address below or ISO's member body in the country of the requester.

ISO copyright office
Case postale 56 • CH-1211 Geneva 20
Tel. + 41 22 749 01 11
Fax + 41 22 749 09 47
E-mail copyright@iso.ch
Web www.iso.ch

Printed in Switzerland

Foreword

ISO (the International Organization for Standardization) is a worldwide federation of national standards bodies (ISO member bodies). The work of preparing International Standards is normally carried out through ISO technical committees. Each member body interested in a subject for which a technical committee has been established has the right to be represented on that committee. International organizations, governmental and non-governmental, in liaison with ISO, also take part in the work. ISO collaborates closely with the International Electrotechnical Commission (IEC) on all matters of electrotechnical standardization.

International Standards are drafted in accordance with the rules given in the ISO/IEC Directives, Part 3.

Draft International Standards adopted by the technical committees are circulated to the member bodies for voting. Publication as an International Standard requires approval by at least 75 % of member bodies casting a vote.

Attention is drawn to the possibility that some of the elements of this International Standard may be the subject of patent rights. ISO shall not be held responsible for identifying any or all such patent rights.

International Standard ISO 8795 was prepared by the European Committee for Standardization (CEN) in collaboration with ISO Technical Committee TC 138, *Plastics pipes, fittings and valves for the transport of fluids*, Subcommittee SC 5, *General properties of pipes, fittings and valves of plastic materials and their accessories — Test methods and basic specifications*, in accordance with the Agreement on technical cooperation between ISO and CEN (Vienna Agreement).

Throughout the text of this standard, read "...this European Standard..." to mean "...this International Standard...".

This third edition cancels and replaces the second edition (ISO 8795:1998), which has been technically revised.

Annexes A and B form a normative part of this International Standard.

Contents

		Page
	Foreword	v
1	Scope	1
2	Normative references	1
3	Terms and definitions	1
4	Principle	2
5	Reagents	2
5.1	Test liquids	2
5.2	General requirements for the liquids	3
5.3	Selection of test liquids to perform the test	3
6	Test temperatures	3
7	Apparatus	3
8	Test pieces	3
8.1	General	3
8.2	Preparation	4
9	Procedure	4
9.1	General	4
9.2	Stagnation	5
9.3	Prewashing	5
9.4	Migration test	6
9.5	Analysis of constituents	6
10	Expression of results	6
11	Test report	7
	Annex A (normative) Test liquids	8
	Annex B (normative) Preparation of test pieces for testing pipes, fittings or joints with nominal size greater than 80	10
	Bibliography	15

Foreword

The text of EN ISO 8795:2001 has been prepared by Technical Committee CEN/TC 155 "Plastics piping systems and ducting systems", the secretariat of which is held by NEN, in collaboration with Technical Committee ISO/TC 138 "Plastics pipes, fittings and valves for the transport of fluids".

This European Standard shall be given the status of a national standard, either by publication of an identical text or by endorsement, at the latest by September 2001, and conflicting national standards shall be withdrawn at the latest by September 2001.

This Standard replaces EN 852-1:1996. This revision contains the addition of requirements for fittings and joints.

NOTE 1 ISO 8795:1998 is a revision of ISO 8795:1990 and is identical with EN 852-1:1996.

It is based on ISO 8795:1990 "*Plastics pipes for the transport of water intended for human consumption - Extractability of constituents - Test method*", published by the International Organisation for Standardisation (ISO). It differs from ISO 8795:1990 due to the need for the test method to be applicable to European conditions and practice.

The main modifications are:

- a) testing of fittings and joints has been added;
- b) test liquids:
 - the addition of neutral water (pH = 7,0) to cover non-European conditions;
 - pH 9 has been added, to cover European conditions (see Directive 98/83/EC Part C);
 - pH 11 is mentioned;
 - addition of test liquid with an active chlorine content of 1 mg/l;
- c) a stagnation period has been added;
- d) exposure time: 72 h is specified for cold water applications and 24 h is specified for warm and hot water applications;
- e) temperatures:
 - 70 °C is specified for moderate hot water conditions;
- f) large diameter pipes, fittings and joints: a procedure for testing has been added.

Annex A, which is normative, describes the preparation of test liquids.

Annex B, which is normative, describes the preparation of test pieces for testing pipes, fittings and joints with nominal sizes greater than 80.

Further is included a bibliography.

This standard is one of a series of standards on test methods which support System Standards for plastics piping systems and ducting systems.

According to the CEN/CENELEC Internal Regulations, the national standards organizations of the following countries are bound to implement this European Standard: Austria, Belgium, Czech Republic, Denmark, Finland, France, Germany, Greece, Iceland, Ireland, Italy, Luxembourg, Netherlands, Norway, Portugal, Spain, Sweden, Switzerland and the United Kingdom.

1 Scope

This standard specifies a method for the determination of the migration of constituents from the internal surface of plastics pipes, fittings and joints. Organoleptic and microbiological assessments are not included.

This standard is applicable to all plastics pipes, fittings and joints to be used for the transport of water intended for human consumption and raw water used for the manufacturing of water intended for human consumption. It covers all constituents which are extractable by water from a finished pipe, fitting or joint. It provides for a change in procedure as necessary depending upon the size of the pipe, fitting or joint.

NOTE 1 It is assumed that the referring standards or regulations making reference to this standard include the following information (see also the note to clause 4):

- a) choice of test liquid(s) (see 5.3);
- b) choice of test temperature(s) (see clause 6).

NOTE 2 The pre-treatment procedures, test liquids and test temperatures mentioned in this standard cover the present situation. When new and/or different conditions are formulated (currently under discussion) the standard will be amended accordingly.

2 Normative references

This European Standard incorporates by dated or undated reference, provisions from other publications. These normative references are cited at the appropriate places in the text and the publications are listed hereafter. For dated references, subsequent amendments to, or revisions of, any of these publications apply to this European Standard only when incorporated in it by amendment or revision. For undated references the latest edition of the publication referred to applies (including amendments).

EN ISO 3696:1995, *Water for analytical laboratory use — Specification and test methods* (ISO 3696:1987)

ISO 7393-2:1985, *Water quality - Determination of free chlorine and total chlorine - Part 2: Colorimetric method using N,N-diethyl-1,4-phenylenediamine, for routine control purposes*

3 Terms and definitions

For the purposes of this standard the following terms and definitions apply.

3.1

migration

movement of substances from one material (e.g. plastics pipe) into another (test liquid)

3.2

test liquid

specified water for migration testing

3.3

migration value (*M*)

mass of constituent(s) migrated from a specified surface area of a test piece exposed to a test liquid at a specified temperature over a specified time

3.4

tapwater

water intended for human consumption

3.5

fitting

component, other than a pipe which is used in a pipeline (e.g. bends, tees, end caps, valves)

3.6

joint

connection between the ends of two components (electrofusion joints are included)

3.7

migration liquid

test liquid which has been in contact with a test piece under specified conditions

3.8

migration number (*n*)

number of migrations conducted sequentially

4 Principle

Test pieces are subjected to stagnation and prewashing with tapwater for a specified time. The test pieces are then filled with the specified test liquid at a specified temperature and kept for a series of specified migration periods. The migration liquid is then analysed to assess any constituents which were able to migrate.

NOTE It is assumed that the following test parameters are set by the standard(s) making reference to this standard:

- a) the test liquid(s) (see 5.3);
- b) the test temperature, *T*, if other than as given in clause 6;
- c) the number of pairs of test pieces (see 9.1.1);
- d) the constituents for which analysis is to be made both upon test pieces and the blank test and the required accuracy, taking account of 9.5 (see also clause 10).

5 Reagents

5.1 Test liquids

NOTE Methods for the preparation of test liquids are given in annex A.

5.1.1 Water, conforming to grade 3 of EN ISO 3696:1995, with the following characteristics:

- a) a conductivity of ≤ 10 mS/m at 25 °C;
- b) total organic carbon (TOC) content $\leq 0,2$ mg/l (as carbon).

5.1.2 Chlorinated water, conforming to 5.1.1 with an active chlorine concentration of $(1 \pm 0,2)$ mg/l.

5.1.3 Acidic water, comprising water conforming to 5.1.1, adjusted to a pH of $(4,5 \pm 0,1)$ with a potassium dihydrogen phosphate (KH_2PO_4) buffer solution conforming to A.1.2.

5.1.4 Chlorinated acidic water, comprising water conforming to 5.1.1, adjusted to a pH of $(4,5 \pm 0,1)$ with a KH_2PO_4 buffer solution conforming to A.1.2 and an active chlorine concentration of $(1 \pm 0,2)$ mg/l.

5.1.5 Alkaline water type I (for European conditions), comprising water conforming to 5.1.1, adjusted to a pH of $(9,0 \pm 0,1)$ with a borate buffer solution conforming to A.1.3.

5.1.6 Alkaline water type II (for non-European conditions), comprising water conforming to 5.1.1, adjusted to a pH of $(11,0 \pm 0,1)$ with a sodiumhydroxide / sodium tetraborate buffer solution conforming to A.1.4.

5.1.7 Neutral water (for non-European conditions), comprising water conforming to 5.1.1, adjusted to a pH of $(7,0 \pm 0,1)$ with a potassium dihydrogen phosphate (KH_2PO_4) buffer solution conforming to A.1.5.

5.2 General requirements for the liquids

The test liquid shall contain negligible concentrations of any measurable substances that could interfere with the measurements of constituents.

5.3 Selection of test liquids to perform the test

5.3.1 For cold water applications the test liquid(s) shall be selected from those given in 5.1.

5.3.2 For warm and hot water applications (see clause 6) the test liquid shall conform to 5.1.1.

6 Test temperatures

Unless otherwise specified in the referring standard or regulations, the test temperature shall be selected from the following:

- a) for cold water applications: (23 ± 2) °C;
- b) for warm water applications: either (60 ± 2) °C or (70 ± 2) °C, depending upon the class of pipe;
- c) for hot water applications: (90 ± 2) °C;
- d) for tropical conditions: (27 ± 2) °C.

7 Apparatus

7.1 Connections, stoppers and containers, made of material which is inert at the specified test conditions, such as glass or PTFE or stainless steel (see also annex B).

NOTE The material PTFE should only be used when there is a small contact area with the test liquid, thus not for containers.

7.2 Thermostatically controlled environment or enclosure, capable of maintaining the relevant test temperature(s) (see clause 6).

8 Test pieces

8.1 General

8.1.1 Sampling of products shall be performed in accordance with the relevant product standard or system standard, as applicable.

NOTE National regulations for sampling may be applicable.

8.1.2 If it is necessary to store samples before testing, they shall be protected from contamination. If the manufacturer provides written instruction on storage, they shall be followed.

The samples shall be stored in their original form as delivered. Where appropriate, storage containers shall be cleaned using the same procedures as are used for test containers.

8.1.3 The test pieces shall be prepared such that only the surfaces intended to come into contact with the water are exposed to test liquids conforming to 5.1. Where the composition of the test pieces is homogeneous, i.e. the inside surface is the same as the outside surface, it is acceptable to immerse the whole test piece(s) in the test liquid.

If the surface area of the product in contact with drinking water consists of more than one material, then the product may be tested as a single unit or the individual materials can be tested either by disassembling the product or by using the procedure in 8.1.4 for each material.

8.1.4 If the procedure for the preparation of a test piece for a particular type of product or material has not been covered in this standard, deviation from this procedure is permitted under the following conditions:

- a) the finished product and the test piece shall be produced in the same manner;

- b) the preparation of test pieces before testing shall include the procedures, which are performed in practice before the system is put into operation, e.g. curing and cleaning procedures.

8.1.5 The surface of the test pieces intended to come into contact with the test liquids shall be free from adhesive tape, labels, ink or pencil marks.

NOTE Care may be necessary to ensure that the transport conditions do not influence the test results.

8.1.6 The minimum age of the test pieces shall be in accordance with the relevant product standard, system standard or, if not given in such a standard, with that recommended by the manufacturer for the product to be ready for use.

8.2 Preparation

8.2.1 Surface-area-to volume ratio (S/V)

The value of S/V shall not be less than $5 (d_m^{-1})$, where:

- S is the inner surface area of the test piece, in square decimetres (d_m^2), exposed to the test liquid;
- V is the volume of the test liquid, in litres.

8.2.2 Pipes

For each test, take length(s) of pipe sufficient to give the volume of the test liquid necessary to determine the amount of any migrated constituent(s) with the required accuracy.

For pipes with nominal sizes in excess of 80, the test arrangement shall be adjusted to one of the methods as given in annex B to meet the requirements of 8.2.1.

8.2.3 Fittings and joints

8.2.3.1 For each test take a fitting or joint or a number of fittings or joints, sufficient to give the volume of the test liquid, necessary to determine the amount of any migrated constituent(s) with the required accuracy.

If it is not possible to carry out this procedure due to practical reasons (e.g. geometry of the fitting or joint) the procedures described in 8.2.3.2 or 8.2.3.3 shall be applied.

8.2.3.2 The product may be tested in the form of a more convenient test piece (e.g. in the form of a pipe) prepared under the same manufacturing and processing conditions as for fittings.

8.2.3.3 When fittings or joints have the same material composition for the outside and inside surfaces, the fittings or joints may be immersed in the test liquid held in a container (see 7.1) and the value for S/V shall be calculated from the total outside and inside surface area.

9 Procedure

9.1 General

9.1.1 Carry out the tests described in 9.2 to 9.5 in duplicate and at the same time.

Stagnation (9.2), prewashing (9.3) and migration (9.4) shall be carried out without delay between the stages.

9.1.2 Carry out a blank test in parallel with 9.1.1, using the same test conditions (test liquid, test temperature, migration time and stoppers) in a container of sufficient volume conforming to 7.1, but made of glass. Determine at the end of each migration period (see 9.4) the concentration, C_0 , of each specified constituent [see d) of the note to clause 4] and associated interfering substances with the required accuracy.

NOTE If a bulk supply of test liquid is used for the duplicate test then one blank test is sufficient.

9.2 Stagnation

9.2.1 Pipes to be tested at 23 °C or 27 °C

9.2.1.1 Fill the test piece(s) (see clause 8) with tapwater, seal with a stopper (see 7.1) or proceed as indicated in annex B, and let it stand for $(24 \pm 0,5)$ h.

9.2.1.2 After this period remove the water and prewash the test piece in accordance with 9.3.

9.2.2 Pipes to be tested at elevated temperatures

9.2.2.1 Perform the procedure in 9.2.1.

9.2.2.2 Fill the test piece(s) with tapwater at the test temperature (see clause 6), seal with a stopper (see 7.1) or as indicated in annex B, and let it stand for $(7,5 \pm 0,5)$ h at the test temperature.

9.2.2.3 After this period, remove the water and refill the test piece(s) with fresh tapwater which has been brought to the test temperature and let it stand for $(16 \pm 0,5)$ h at the test temperature.

9.2.2.4 After this period, remove the water and rinse the test piece(s) in accordance with 9.3.5.

9.2.3 Fittings and joints to be tested at 23 °C or 27 °C

9.2.3.1 If applicable, subject the test piece(s) to stagnation in accordance with 9.2.1.

9.2.3.2 If 9.2.3.1 is not applicable, e.g. for shape and/or size reasons (see clause 8), immerse the test piece(s) (see 8.2.3) in tapwater in a container (see 7.1) for $(24 \pm 0,5)$ h.

Remove the water and prewash the test piece(s) in accordance with 9.3.

9.2.4 Fittings and joints to be tested at elevated temperatures

9.2.4.1 Perform the procedure in accordance with 9.2.3 (see 9.2.4.4).

9.2.4.2 Fill the test piece(s) with tapwater at the test temperature (see clause 6), seal with a stopper (see 7.1) or as indicated in annex B and let it stand for $(7,5 \pm 0,5)$ h at the test temperature.

9.2.4.3 Remove the water and refill the test piece(s) with fresh tapwater, which has been brought to the test temperature and let it stand for $(16 \pm 0,5)$ h at the test temperature. Remove the water and rinse the test piece(s) using water conforming to 5.1.1.

9.2.4.4 If 9.2.4.1 is not applicable, e.g. for shape and/or size reasons (see clause 8), immerse the test piece(s) (see 8.2.3) in tapwater at the test temperature (see clause 6) in a container (see 7.1) and let it stand for $(7,5 \pm 0,5)$ h at the test temperature.

9.2.4.5 Remove the water and immerse the test piece(s) in fresh tapwater which has been brought to the test temperature and let it stand for $(16 \pm 0,5)$ h at the test temperature.

9.2.4.6 Remove the water and rinse the test piece(s) using water conforming to 5.1.1.

9.3 Prewashing

9.3.1 If applicable (see 9.3.4), connect the test piece(s) to a source of tapwater via a suitable connector (see 7.1) such that the test surface is totally covered during prewashing. Complete prewashing in accordance with 9.3.2 to 9.3.4 inclusive.

9.3.2 Let the tapwater flow through the test piece with a velocity between 2 m/min and 4 m/min.

9.3.3 Maintain the water flow for a period between 60 min and 70 min.

9.3.4 If 9.3.1 is not applicable, e.g. for shape or size reasons (see clause 8), place the test piece(s) in an appropriate container (e.g. bucket) having a water throughflow from the bottom upwards such that the calculated velocity with regard to the upper open surface of the container is between 2 m/min and 4 m/min for a period between 60 min and 70 min.

9.3.5 Stop the water flow and rinse the test piece(s) using water conforming to 5.1.1.

9.4 Migration test

9.4.1 If applicable (see 9.4.2.) fill the test piece(s) (see clause 8) with the specified test liquid (see clause 4 and 5.1), seal with stoppers (see 7.1) or as indicated in annex B and maintain the filled test piece at the specified temperature for (72 ± 1) h for cold water applications or for (24 ± 1) h for warm and hot water applications (see 9.4.2).

9.4.2 If 9.4.1 is not applicable, e.g. for shape and/or size reasons (see clause 8), immerse the test piece(s) in the specified test liquid (see clause 4 and 5.1) at the specified temperature in a container (see 7.1) for (72 ± 1) h for cold water applications or for (24 ± 1) h for warm and hot water applications.

9.4.3 At the end of the first migration, collect the migration liquid (see 3.7) in a suitable container, i.e. complying with analytical requirements, and if applicable allow to cool down to room temperature.

9.4.4 For any subsequent migration (n) repeat the steps described in 9.4.1 to 9.4.3 where n corresponds to the number of times those steps have been carried out (the migration number).

9.5 Analysis of constituents

Carry out the required analysis on the migration liquid (see 9.4.3 and 9.4.4) using appropriate analytical methods where the extracted substances to be determined and the limits of detection and accuracy, i.e. total tolerable random (precision) and systematic (bias) error of the analytical results, shall be as specified in the referring standard(s).

10 Expression of results

The measured concentrations of the relevant constituent(s) shall be expressed in milligrams per litre (mg/l). The migration value, M , for a migrated constituent shall be calculated using one of the following equations:

For cold water applications:

$$M_{24} = \frac{1}{3} C_{72} \times \frac{V}{S}$$

or for warm and hot water applications:

$$M_{24} = C_{24} \times \frac{V}{S}$$

where:

M_{24} is the migration value, in milligrams per square decimetre (mg/dm²) per 24 h;

C_{24} is the concentration of the migrated amount of each constituent, in milligrams per litre (mg/l) over a period of 24 h, where $C_{24} = C_1$ {or C_n } - C_0 ;

C_{72} is the concentration of the migrated amount of each constituent, in milligrams per litre (mg/l) over a period of 72 h, where $C_{72} = C_1$ {or C_n } - C_0 ,

where:

C_0 is the concentration in the blank (see 9.1.2); C_1 (or C_n) is the concentration in the first (or n) migration.

V is the volume of migration liquid, in litres;

S is the surface area of test piece, in square decimetres (dm²), exposed to the test liquid.

The results for M and C shall be expressed as $M_{t,n}^T$ and $C_{t,n}^T$, where:

- T is the migration temperature, in degrees Celsius;
- t is the migration time, in hours;
- n is the sequence number of the migration period.

EXAMPLES:

$M_{24;1}^{23}$ is M for the first migration at 23 °C for a migration time, t , of 72 h divided by 3;

$M_{24;3}^{70}$ is M for the third migration at 70 °C for a migration time, t , of 24 h;

$C_{72;1}^{23}$ is C for the first migration at 23 °C for a migration time, t , of 72 h;

$C_{24;3}^{70}$ is C for the third migration at 70 °C for a migration time, t , of 24 h;

NOTE The migration value, M , is independent of the size of the test piece and is expressed in mass per unit area per unit time. While the migration time is 72 h and the unit time is 24 h the factor 1/3 is introduced in the equation. For practical reasons it is assumed that the migration is linear in time. From the expression of M as $M_{t,n}^T$ it is easy to read which migration time, t , in hours, and which migration temperature, T , in degrees Celsius, and which sequence number, n , of the migration period was used.

11 Test report

The test report shall include the following information:

- a) a reference to this standard and to the referring standard;
- b) a complete identification of the test piece(s), including the following:
 - name of manufacturer and production site;
 - name and type of material;
 - marking including production code;
 - dimensions of the sample: nominal size and nominal wall thickness;
 - description of the test piece(s);
 - the age of the test piece (see 8.1.6);
- c) the analytical method, its accuracy and the detection limit used for the determination of the constituent(s) concerned;
- d) the volume of the migration liquid, V , in litres, and the surface area of the test piece(s) exposed to the test liquid, S , in square decimetres (dm^2);
- e) the test liquid and the test temperature;
- f) Concentrations $C_{72;n}^T$ or $C_{24;n}^T$ and C_0 in milligrams per litre (mg/l) and the calculated migration value $M_{24;n}^T$ in $\text{mg}/(\text{dm}^2 \cdot 24\text{h})$ of each constituent determined after the first and any subsequent migration;
- g) the arithmetic mean of $C_{72;n}^T$ or $C_{24;n}^T$ and $M_{24;n}^T$;
- h) any deviations from this standard with regard to instructions, procedures, test conditions, etc. likely or unlikely to affect the results;

NOTE This does not imply that such deviations are permitted. Practice, however, showed that such deviations occur because the impact is underestimated or it is not realised that this may have an influence on the results.
- i) the date of test.

Annex A (normative)

Test liquids

A.1 Chemical solutions

A.1.1 Sodium hypochlorite (NaOCl) solution

A solution of sodium hypochlorite (NaOCl) in water conforming to 5.1.1 with a concentration of 0,1 % (by mass) available chlorine is prepared on the day of use by dilution of a sodium hypochlorite solution (technical grade) with water conforming to 5.1.1.

NOTE The sodium hypochlorite solution is not sufficiently stable for prior preparation.

A.1.2 Acidic buffer solution (pH 4,5)

An acidic buffer solution is prepared by dissolving 13,61 g of potassium dihydrogen phosphate (KH_2PO_4) in 1000 ml of water conforming to 5.1.1 and diluting this solution by 1 : 100 with water conforming to 5.1.1.

1,2 ml of 0,1 N HCl per litre diluted solution is then added.

A.1.3 Alkaline buffer solution (pH 9,0)

An alkaline stock buffer solution with a pH of 9,0 is prepared by mixing 420 ml of solution A and 1000 ml of solution B as follows.

Solution A shall comprise of 0,1 N sodium hydroxide (NaOH) prepared in water conforming to 5.1.1.

Solution B is prepared by dissolving 6,18 g of boric acid in 0,1 M potassium chloride made with water conforming to 5.1.1 and diluting to (1000 ± 1) ml with the same (0,1 M potassium chloride) solution.

This alkaline stock buffer solution is diluted 1 : 100 with water conforming to 5.1.1.

A.1.4 Alkaline buffer solution (pH 11,0)

An alkaline stock buffer solution with a pH of 11,0 is prepared by mixing 49,5 ml of sodium hydroxide (NaOH) solution and 50,5 ml of a sodium tetraborate ($\text{Na}_2\text{B}_4\text{O}_7 \cdot 10\text{H}_2\text{O}$) solution.

The sodium hydroxide solution is 0,1 mol/l.

The sodium tetraborate solution is 0,05 mol/l.

A.1.5 Neutral buffer solution (pH 7,0)

A neutral stock buffer solution with a pH of 7,0 is prepared by mixing 29,6 ml of solution A and 50,0 ml of solution B.

Solution A shall comprise of 0,1 N sodium hydroxide (NaOH) prepared in water conforming to 5.1.1.

Solution B is prepared by dissolving 13,61 g of potassium dihydrogen phosphate (KH_2PO_4) in 1000 ml of water conforming to 5.1.1

A.2 Preparation of test liquids

A.2.1 Water having an active chlorine concentration

Add a sufficient quantity of a sodium hypochlorite (NaOCl) solution conforming to A.1.1 to water conforming to 5.1.1 to give an active chlorine concentration of $(1,0 \pm 0,2)$ mg/l.

Determine this concentration in accordance with ISO 7393-2:1985.

A.2.2 Acidic water

Add to water conforming to 5.1.1 enough phosphate buffer solution conforming to A.1.2 to obtain a pH of $(4,5 \pm 0,1)$.

A.2.3 Acidic water with an active chlorine concentration

Determine in accordance with ISO 7393-2:1985 the active chlorine concentration in the acidic water conforming to A.2.2. Add a sufficient quantity of a sodium hypochlorite (NaOCl) solution conforming to A.1.1 to give an active chlorine concentration of $(1,0 \pm 0,2)$ mg/l.

A.2.4 Alkaline water type I (pH 9,0)

Add to water conforming to 5.1.1 enough alkaline buffer solution conforming to A.1.3 to obtain a stable pH of $(9,0 \pm 0,1)$.

A.2.5 Alkaline water type II (pH 11,0)

Add to water conforming to 5.1.1 enough alkaline buffer solution conforming to A.1.4 to obtain a stable pH of $(11,0 \pm 0,1)$.

A.2.6 Neutral water (pH 7,0)

Add to water conforming to 5.1.1 enough neutral buffer solution conforming to A.1.5 to obtain a stable pH of $(7,0 \pm 0,1)$.

Annex B (normative)

Preparation of test pieces for testing pipes, fittings or joints with nominal size greater than 80

B.1 General

These arrangements are designed for large diameter pipes. It is possible to test some fittings and joints as pipes using these arrangements. However, some fittings and joints, due to irregular shape, may need to be tested in the form of a pipe (see clause 8).

B.2 Arrangements for testing

Use one of the test arrangements shown in Figures B.1 and B.2 and calculate the dimensions of the test piece for test arrangement 1 according to B.3.

Take precautions to ensure that there is no loss of test liquid during the migration periods.

B.3 Sealing

Seal the test assembly by mechanical fixing as follows.

Secure the end pieces against the test piece(s) to provide a seal e.g. by means of clamps or bolts. If a seal cannot be achieved then use PTFE tape or film in the form of a gasket, with minimal surface in contact with test liquid (see 7.1).

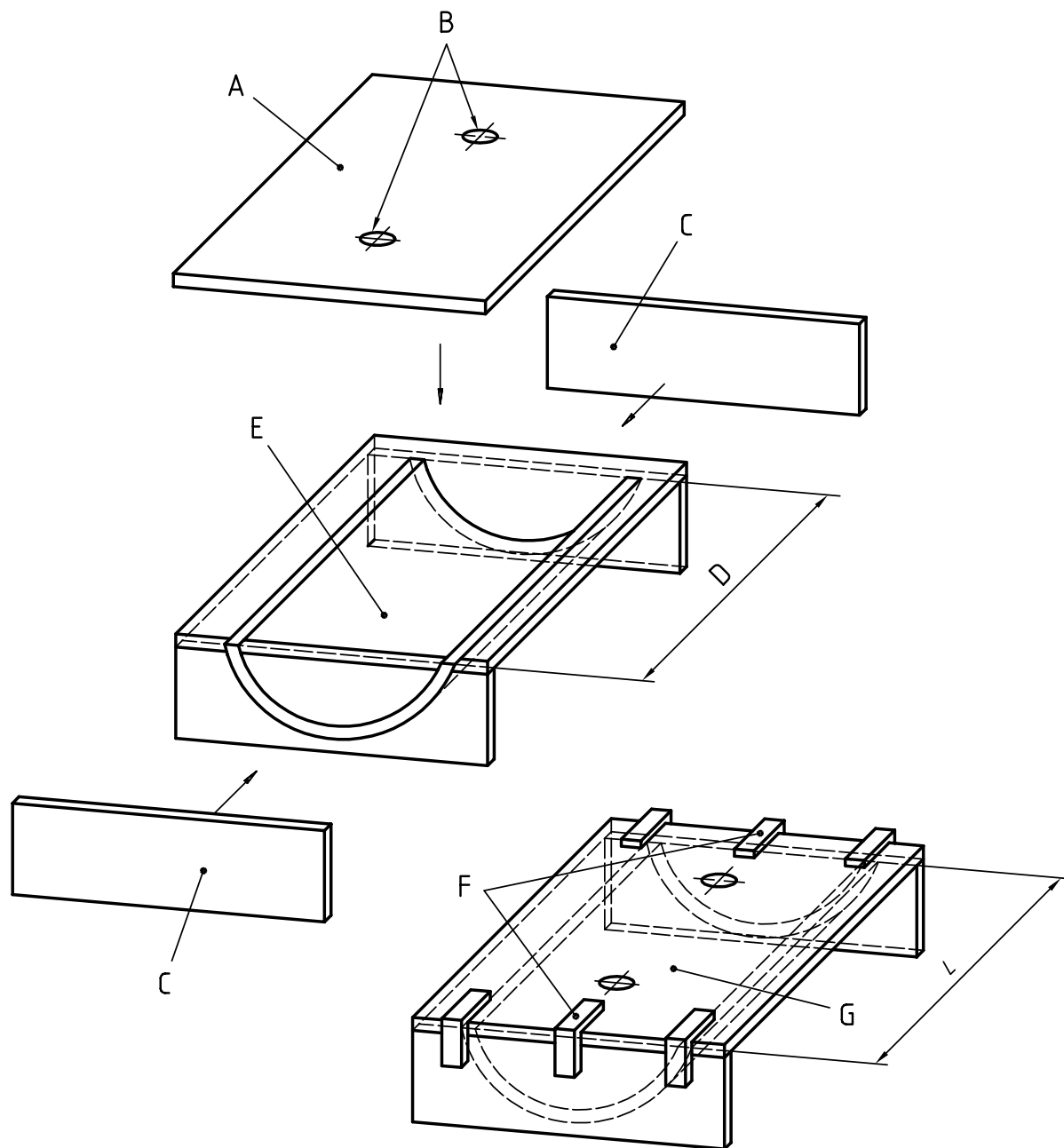

- Key**
- A Cover of glass or stainless steel
 - B Filling and/or air-escape hole
 - C End piece of stainless steel
 - D Length of test piece (L)
 - E Test piece
 - F Clamps or bolts
 - G Test piece completely filled with test liquid

Figure B.1 — Test arrangement 1

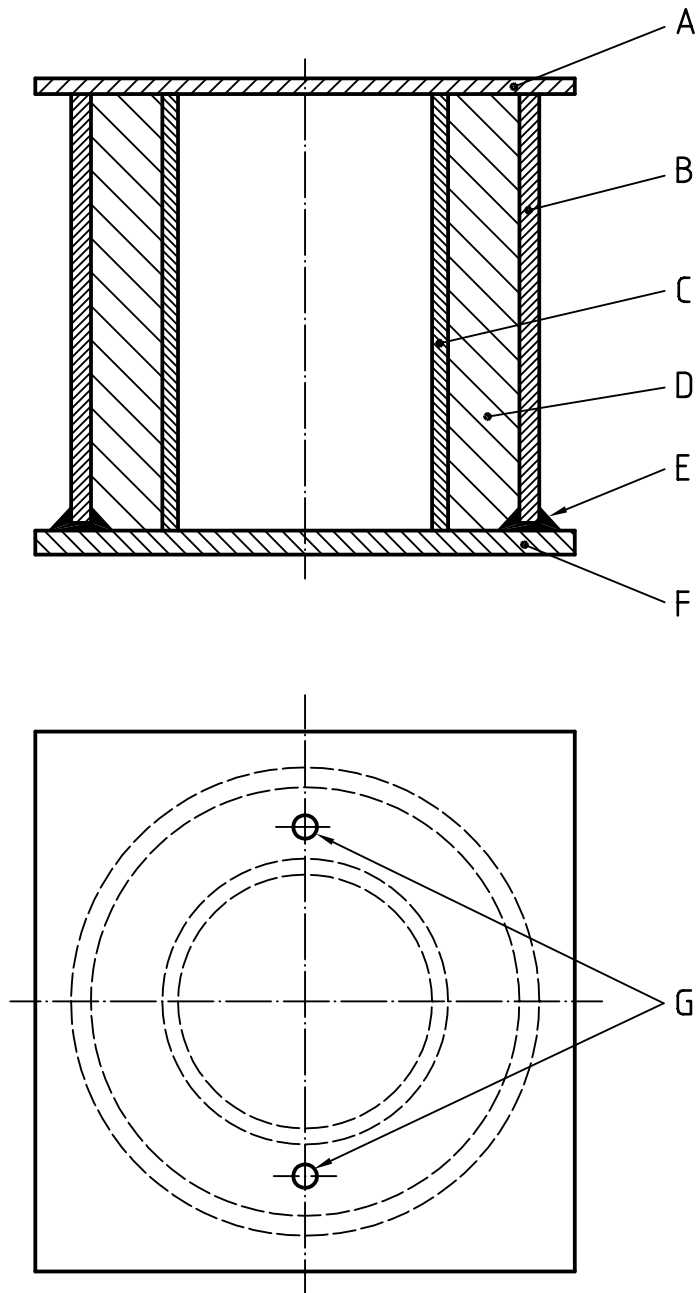

Key

- A Top plate of glass or stainless steel
- B Wall of the test piece
- C Cylinder of glass or stainless steel
- D Test liquid (completely filled)
- E PTFE seal between test piece and plate
- F Bottom plate of glass or stainless steel
- G Filling and/or air-escape hole in top plate

Figure B.2 — Test arrangement 2

B.4 Calculation of the S/V value for test arrangement 1

Calculate the S/V value for test arrangement B.1 when S and V are calculated as follows.

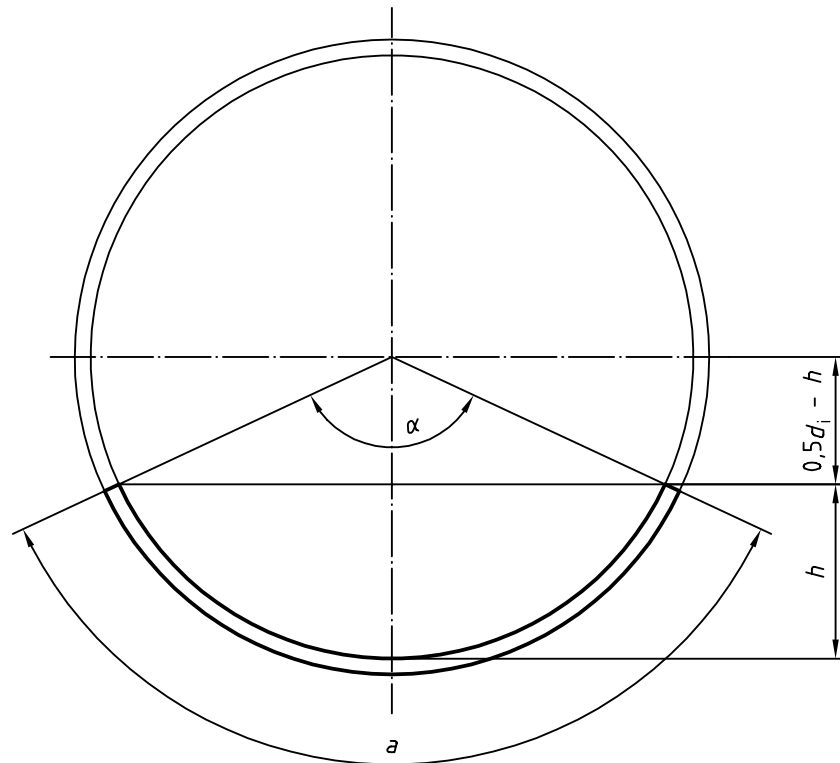

Key

- a Arc length pipe segment
- h Height pipe segment

Figure B.3 — Cross-section of a circular segment

From the cross-section of the circular segment, calculate the arc length, a , and the surface area, A , of the hatched circle segment using the following equations:

$$a = \frac{\alpha}{360} \times \pi d_i \quad (\text{B.1})$$

where:

- a is the arc length, in millimetres;
- d_i is the internal diameter of the test piece from which the segment is taken, in millimetres;
- α is the sector angle, in degrees i.e.

$$\cos\left(\frac{1}{2}\alpha\right) = \frac{d_i - 2h}{d_i} \quad (\text{B.2})$$

where:

- h is the height of the segment, in millimetres.

$$A = \left[\frac{\alpha}{360} \times \frac{1}{4} \pi d_i^2 \right] - \left[\left(\frac{1}{2} d_i - h \right)^2 \times \tan\left(\frac{1}{2}\alpha\right) \right] \quad (\text{B.3})$$

where:

ISO 8795:2001(E)

- A is the surface area of the hatched circle segment, in square millimetres (mm^2);
- α is the sector angle, in degrees;
- h is the height of the segment, in millimetres;
- d_i is the internal diameter of the test piece from which the segment is taken, in millimetres.

$$S = 10^{-4} \times a \times L \quad (\text{B.4})$$

where:

- S is the surface area of the test piece (pipe segment) exposed to the test liquid, in square decimetres (dm^2);
- a is the arc length of the circular segment, in millimetres;
- L is the length of the circular segment, in millimetres.

$$V = 10^{-6} \times A \times L \quad (\text{B.5})$$

where:

- V is the volume of the test liquid, in litres;
- A is the surface area of the surface area of the hatched circle segment, in square millimetres (mm^2);
- L is the length of the circular segment, in millimetres.

Bibliography

Directive 98/83/EC, *Directive of the Council of 5 November 1998 on the quality of the water intended for human consumption.*

ISO 8795:2001(E)

.....

ICS 23.040.20; 91.140.60

Price based on 15 pages

© ISO 2001 – All rights reserved