

---

---

**Assembly tools for screws and nuts —  
Screwdrivers for cross-recessed head  
screws —**

Part 2:  
**General requirements, lengths of blades  
and marking of hand-operated  
screwdrivers**

*Outils de manœuvre pour vis et écrous — Tournevis pour vis  
à empreinte cruciforme —*

*Partie 2: Spécifications générales, longueurs des lames et marquage  
des tournevis à main*



**PDF disclaimer**

This PDF file may contain embedded typefaces. In accordance with Adobe's licensing policy, this file may be printed or viewed but shall not be edited unless the typefaces which are embedded are licensed to and installed on the computer performing the editing. In downloading this file, parties accept therein the responsibility of not infringing Adobe's licensing policy. The ISO Central Secretariat accepts no liability in this area.

Adobe is a trademark of Adobe Systems Incorporated.

Details of the software products used to create this PDF file can be found in the General Info relative to the file; the PDF-creation parameters were optimized for printing. Every care has been taken to ensure that the file is suitable for use by ISO member bodies. In the unlikely event that a problem relating to it is found, please inform the Central Secretariat at the address given below.

© ISO 2004

All rights reserved. Unless otherwise specified, no part of this publication may be reproduced or utilized in any form or by any means, electronic or mechanical, including photocopying and microfilm, without permission in writing from either ISO at the address below or ISO's member body in the country of the requester.

ISO copyright office  
Case postale 56 • CH-1211 Geneva 20  
Tel. + 41 22 749 01 11  
Fax + 41 22 749 09 47  
E-mail [copyright@iso.org](mailto:copyright@iso.org)  
Web [www.iso.org](http://www.iso.org)

Published in Switzerland

## Foreword

ISO (the International Organization for Standardization) is a worldwide federation of national standards bodies (ISO member bodies). The work of preparing International Standards is normally carried out through ISO technical committees. Each member body interested in a subject for which a technical committee has been established has the right to be represented on that committee. International organizations, governmental and non-governmental, in liaison with ISO, also take part in the work. ISO collaborates closely with the International Electrotechnical Commission (IEC) on all matters of electrotechnical standardization.

International Standards are drafted in accordance with the rules given in the ISO/IEC Directives, Part 2.

The main task of technical committees is to prepare International Standards. Draft International Standards adopted by the technical committees are circulated to the member bodies for voting. Publication as an International Standard requires approval by at least 75 % of the member bodies casting a vote.

Attention is drawn to the possibility that some of the elements of this document may be the subject of patent rights. ISO shall not be held responsible for identifying any or all such patent rights.

ISO 8764-2 was prepared by Technical Committee ISO/TC 29, *Small tools*, Subcommittee SC 10, *Assembly tools for screws and nuts, pliers and nippers*.

This second edition cancels and replaces the first edition (ISO 8764-2:1992), which has been technically revised as follows:

- a designation has been added;
- in the English version, the term “point” becomes “tip” and “type” becomes “form”;
- in the French version, the term “type” becomes “forme”.

ISO 8764 consists of the following parts, under the general title *Assembly tools for screws and nuts — Screwdrivers for cross-recessed head screws*:

- *Part 1: Driver tips*
- *Part 2: General requirements, lengths of blades and marking of hand-operated screwdrivers*



# Assembly tools for screws and nuts — Screwdrivers for cross-recessed head screws —

## Part 2: General requirements, lengths of blades and marking of hand-operated screwdrivers

### 1 Scope

This part of ISO 8764 specifies general requirements, lengths of blades and marking of hand-operated screwdrivers for H and Z cross-recessed head screws, as specified in ISO 4757.

The specifications for blade tips are given in ISO 8764-1.

NOTE Screwdrivers for cross-recessed head screws are listed under number 106 in ISO 1703:1983.

### 2 Normative references

The following referenced documents are indispensable for the application of this document. For dated references, only the edition cited applies. For undated references, the latest edition of the referenced document (including any amendments) applies.

ISO 272, *Fasteners — Hexagon products — Widths across flats*

ISO 4759-1, *Tolerances for fasteners — Part 1: Bolts, screws, studs and nuts — Product grades A, B and C*

ISO 8764-1, *Assembly tools for screws and nuts — Screwdrivers for cross-recessed head screws — Part 1: Driver tips*

### 3 General requirements

The material, shape and finish of the handle shall ensure use under normal conditions.

The handle and the blade shall show neither roughness nor faults which could cause accidents during use.

### 4 Blade lengths

The lengths of blades are specified in Table 1 according to the sizes of tip forms PH and PZ of the screwdrivers as defined in ISO 8764-1. Two series of lengths are provided.

NOTE Figures 1 and 2 are given as examples and are not intended to affect the manufacturer's design.

**Table 1 — Lengths of screwdriver blades for cross-recessed head screws**

Dimensions in millimetres

Tip sizes for driver forms PH and PZ No.	<i>l</i> +5 0	
	Series A	Series B
0	25 (35)	60
1	25 (35)	75 (80)
2	25 (35)	100
3	—	150
4	—	200

NOTE The dimensions in parentheses are non-preferred.

From tip size 2, screwdrivers with hexagonal driver near the handle are permitted (see Figure 2); widths across flats *s* and the corresponding tolerances shall be in accordance with ISO 272 and ISO 4759-1. The dimensions *h<sub>min</sub>* is determined by the formula

$$h_{\min} = 0,5 s.$$

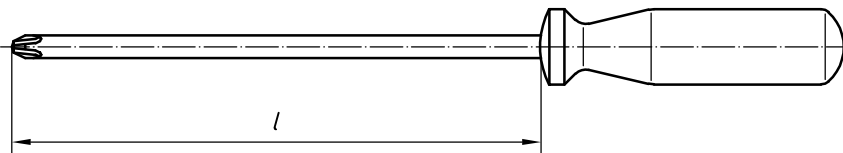

**Figure 1 — Screwdriver**

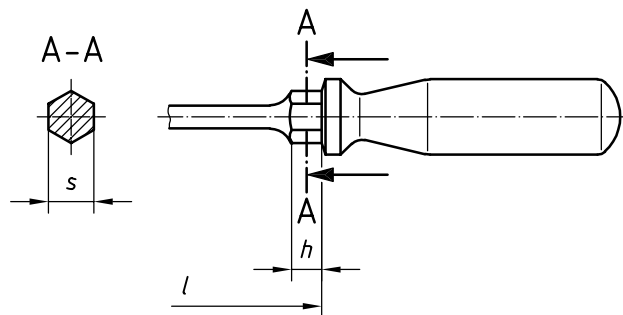

**Figure 2 — Hexagonal driver near the handle**

## 5 Designation

EXAMPLE 1 Designation of a screwdriver, series A, tip form PH, size 2:

**Screwdriver ISO 8764-2 — A — PH2**

EXAMPLE 2 Designation of a screwdriver, series B, tip form PZ, size 3:

**Screwdriver ISO 8764-2 — B — PZ3**

## 6 Marking

The marking of the form of tip, PZ or PH, the tip size and the trademark shall be legible and indelible under normal conditions of use. Indication of the blade length is optional, but when given it shall correspond to the nominal length given in Table 1.

## Bibliography

- [1] ISO 1703, *Assembly tools for screws and nuts — Nomenclature*
- [2] ISO 4757, *Cross recesses for screws*





---

---

**ICS 25.140.30**

Price based on 4 pages