International Standard



8737

INTERNATIONAL ORGANIZATION FOR STANDARDIZATION • МЕЖДУНАРОДНАЯ ОРГАНИЗАЦИЯ ПО СТАНДАРТИЗАЦИИ • ORGANISATION INTERNATIONALE DE NORMALISATION

Taper pins with external thread, unhardened

Goupilles de position coniques à longueur filetée, non trempées

First edition — 1986-11-01

UDC 621.886.114

Ref. No. ISO 8737-1986 (E)

Descriptors : fasteners, pins (mechanics), taper pins, specifications, dimensions, designation.

ISO 8737-1986 (E)

Foreword

ISO (the International Organization for Standardization) is a worldwide federation of national standards bodies (ISO member bodies). The work of preparing International Standards is normally carried out through ISO technical committees. Each member body interested in a subject for which a technical committee has been established has the right to be represented on that committee. International organizations, governmental and non-governmental, in liaison with ISO, also take part in the work.

Draft International Standards adopted by the technical committees are circulated to the member bodies for approval before their acceptance as International Standards by the ISO Council. They are approved in accordance with ISO procedures requiring at least 75 % approval by the member bodies voting.

International Standard ISO 8737 was prepared by Technical Committee ISO/TC 2, *Fasteners*.

Users should note that all International Standards undergo revision from time to time and that any reference made herein to any other International Standard implies its latest edition, unless otherwise stated.

Taper pins with external thread, unhardened

1 Scope and field of application

This International Standard specifies the characteristics of unhardened taper pins with external thread, and metric dimensions and nominal diameters, d_1 , from 5 to 50 mm inclusive.

2 References

ISO 965, *ISO general purpose metric screw threads — Tolerances.*

ISO 2081, *Metallic coatings — Electroplated coatings of zinc on iron or steel.*

ISO 3269, *Fasteners — Acceptance inspection.*

ISO 4520, *Chromate conversion coatings on electroplated zinc and cadmium coatings.*

3 Dimensions

Surface roughness values in micrometres

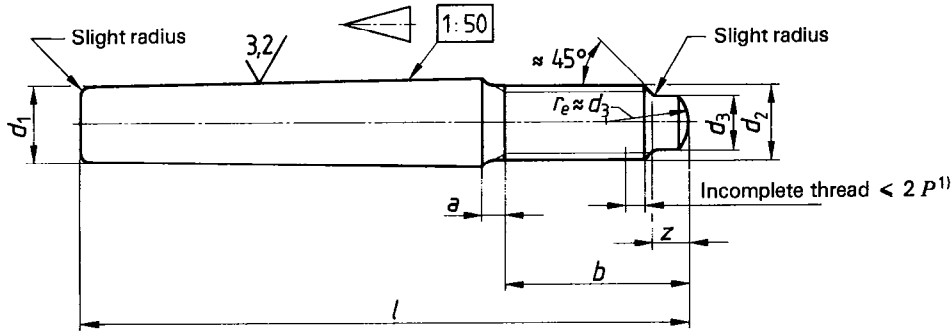

Dimensions in millimetres

d_1	$h10^{2)}$	5	6	8	10	12	16	20	25	30	40	50
a	max.	2,4	3	4	4,5	5,3	6	6	7,5	9	10,5	12
b	max.	15,6	20	24,5	27	30,5	39	39	45	52	65	78
	min.	14	18	22	24	27	35	35	40	46	58	70
d_2		M5	M6	M8	M10	M12	M16	M16	M20	M24	M30	M36
$p^{1)}$		0,8	1	1,25	1,5	1,75	2	2	2,5	3	3,5	4
d_3	max.	3,5	4	5,5	7	8,5	12	12	15	18	23	28
	min.	3,25	3,7	5,2	6,6	8,1	11,5	11,5	14,5	17,5	22,5	27,5
z	max.	1,5	1,75	2,25	2,75	3,25	4,3	4,3	5,3	6,3	7,5	9,4
	min.	1,25	1,5	2	2,5	3	4	4	5	6	7	9
$l^{3)}$												
nom.	min.	max.										
40	39,5	40,5										
45	44,5	45,5										
50	49,5	50,5										
55	54,25	55,75	Range									
60	59,25	60,75										
65	64,25	65,75										
75	74,25	75,75	of									
85	84,25	85,75										
100	99,25	100,75										
120	119,25	120,75	commercial									
140	139,25	140,75										
160	159,25	160,75										
190	189,25	190,75	lengths									
220	219	221										
250	249	251										
280	279	281										
320	319	321										
360	359	361										
400	399	401										

- 1) P = thread pitch.
- 2) Other tolerances as agreed between customer and supplier.
- 3) For nominal lengths above 400 mm, steps of 40 mm.

4 Specifications and reference International Standards

Screw thread	Metric screw thread with tolerance 6g to ISO 965.
Material	St = Free-cutting steel, hardness 125 to 245 HV. Other materials as agreed between customer and supplier.
Surface finish	Plain, i.e. pins to be supplied in natural finish, treated with rust-preventative lubricant, unless otherwise specified by agreement between customer and supplier.
	Preferred coatings are black oxide, phosphate coating or zinc plating with chromate conversion coating (see ISO 2081 and ISO 4520). Other coatings as agreed between customer and supplier. All tolerances shall apply prior to the application of a plating or coating.
Workmanship	Parts shall be uniform in quality and free of irregularities or detrimental defects. No burrs shall appear on any part of the pin.
Taper	The taper shall be inspected by use of an adequate optical comparator.
Acceptability	The acceptance procedure is covered in ISO 3269.

5 Designation

Example for the designation of an unhardened steel taper pin with external thread, nominal diameter $d_1 = 6$ mm and nominal length $l = 50$ mm :

Taper pin ISO 8737 - 6 × 50 - St