

INTERNATIONAL STANDARD

ISO
8645

First edition
1988-09-15



INTERNATIONAL ORGANIZATION FOR STANDARDIZATION
ORGANISATION INTERNATIONALE DE NORMALISATION
МЕЖДУНАРОДНАЯ ОРГАНИЗАЦИЯ ПО СТАНДАРТИЗАЦИИ

Mopeds — Light-alloy wheels — Test method

Cyclomoteurs — Roues en alliages légers — Méthode d'essai

Reference number
ISO 8645 : 1988 (E)

Foreword

ISO (the International Organization for Standardization) is a worldwide federation of national standards bodies (ISO member bodies). The work of preparing International Standards is normally carried out through ISO technical committees. Each member body interested in a subject for which a technical committee has been established has the right to be represented on that committee. International organizations, governmental and non-governmental, in liaison with ISO, also take part in the work. ISO collaborates closely with the International Electrotechnical Commission (IEC) on all matters of electrotechnical standardization.

Draft International Standards adopted by the technical committees are circulated to the member bodies for approval before their acceptance as International Standards by the ISO Council. They are approved in accordance with ISO procedures requiring at least 75 % approval by the member bodies voting.

International Standard ISO 8645 was prepared by Technical Committee ISO/TC 22, *Road vehicles*.

Users should note that all International Standards undergo revision from time to time and that any reference made herein to any other International Standard implies its latest edition, unless otherwise stated.

Mopeds — Light-alloy wheels — Test method

1 Scope

This International Standard specifies methods for determining the reliability of light-alloy road wheels under normal use stress.

2 Field of application

This International Standard applies to wheels for mopeds with two or three wheels as defined in ISO 3833, of the following types:

- unit construction light-alloy wheels;
- composite construction light-alloy wheels.

3 References

ISO 3833, *Road vehicles — Types — Terms and definitions*.

ISO 5995-1, *Moped tyres and rims — Part 1: Tyres*.

4 Definitions

For the purposes of this International Standard, the following definitions apply.

4.1 unit construction light-alloy wheel: Wheel of which the rim and spokes, or the disc, are manufactured as a single unit.

4.2 composite construction light-alloy wheel: Wheel of which the rim is made of light-alloy, and the spokes or disc are made of light-alloy or steel, which are then assembled.

5 Tests

The tests to be carried out are the following:

- a) rotation bending fatigue test (dynamic cornering fatigue test for three-wheelers) (see clause 6);
- b) radial load durability test (see clause 7);
- c) radial impact resistance test (see clause 8);
- d) torsion test (see clause 9);
- e) air leak test (applicable only to wheels designed and marked for use with tubeless tyres) (see clause 10).

A different wheel shall be used for each test.

6 Rotation bending fatigue test (dynamic cornering fatigue test for three-wheelers)

6.1 Test equipment

The test equipment shall be planned to produce a constant bending moment on the centre of the light-alloy wheel which rotates with a constant velocity. An example of such equipment is shown in figure 1.

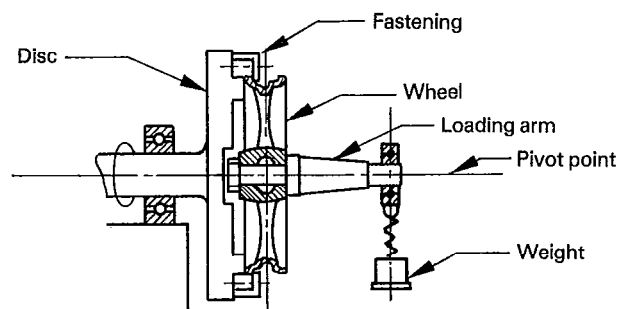

Figure 1 — Model equipment for cornering fatigue test

6.2 Test conditions

6.2.1 Bending moment

The bending moment, M , in decanewton metres, applied in accordance with 6.3 shall be determined by the following equation:

$$M = S_m \cdot \mu \cdot W \cdot r$$

where

S_m is a coefficient equal to 0,7;

μ is the friction coefficient between tyre and road, equal to 0,7;

W is the maximum design load marked on the wheel, in decanewtons;

r is the maximum static radius in metres among those tyres that can be fitted to the wheel.

6.2.2 Loading arm length

The length of the loading arm shall be such that the calculated moment M , is obtained by applying a mass equal to W as defined in 6.2.1.

6.3 Test procedure

Rotate the test equipment with the bending moment M , determined in accordance with 6.2.1, applied, after the rim flange of the light-alloy test wheel has been fixed to the driven rotating disc (see figure 1). A loading arm of the length specified in 6.2.2 of sufficient rigidity shall be attached to the wheel by the same method as the wheel is normally attached to the vehicle.

7 Radial load durability test

7.1 Test equipment

The test equipment, of which figure 2 shows an example, shall meet the following requirements:

a) the test equipment shall have a drum, of diameter ≥ 400 mm, with a smooth surface which is wider than the overall width of the tyre used in the test;

b) the drum specified in a) shall rotate at a constant velocity;

c) the test equipment shall permit a radial load to be applied to the wheel and shall be such that the wheel is maintained in contact with the drum under constant pressure.

7.2 Test conditions

7.2.1 Static radial load

The radial load, Q , in decanewtons, to be applied in 7.3 shall be determined by the equation:

$$Q = S_r \cdot W$$

where

S_r is a coefficient equal to 2,25;

W is as defined in 6.2.1.

7.2.2 Tyre air pressure

The air pressure before the test, in kilopascals, shall be at least that corresponding to the design maximum load of the moped tyre to be used in the test, in accordance with ISO 5995-1.

7.2.3 Tolerance for load fluctuation

The tolerance for load fluctuation during the test shall be $\pm 5\%$.

7.2.4 Tyre failure

In case of tyre failure, the test shall be continued after replacing the tyre.

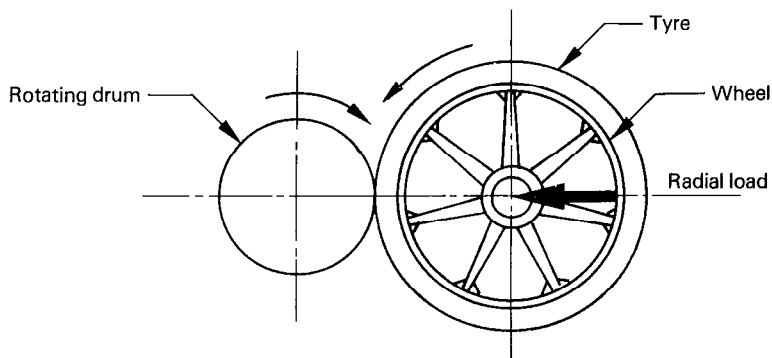

Figure 2 — Model equipment for radial load durability test

7.3 Test procedure

Fit the light-alloy wheel, with a tyre the rated load of which is at least equal to that marked on the wheel, to the test equipment (see figure 2) according to the method used to attach the wheel to the vehicle. The drum shall then be rotated while the radial load Q , determined in accordance with 7.2.1, is applied.

8 Radial impact resistance test

8.1 Test equipment

The equipment shall provide the following characteristics:

- the light-alloy wheel with a tyre attached can be mounted on a bench;
- the mount on which the wheel is anchored shall have sufficient stiffness and strength;
- a striker weight which shall be at least 1,5 times the width of the rim shall be dropped freely to strike the wheel/tyre assembly.

Figure 3 shows examples of such equipment. In the case of equipment using a pendulum [see figure 3a)], the minimum length of the pendulum arm shall be not less than 800 mm measured from the pivot point to the edge of the striker.

8.2 Test conditions

8.2.1 Impact energy

By using the test equipment indicated in 8.1, the striker shall be allowed to drop to apply the impact energy. The total energy, E , in decanewton metres, of the striker at the moment of its striking the tyre shall be determined by the equation:

$$E = K \cdot W$$

where

K is a coefficient of 1,8 m for front wheels, and 1 m for rear wheels;

W is as defined in 6.2.1.

8.2.2 Tyre inflation pressure

The tyre inflation pressure, p , in kilopascals, shall be determined by the following equation:

$$p = (\text{the air pressure corresponding to the design maximum load of the tyre to be used in the test} \times 1,15) \pm 10$$

8.2.3 Striker mass and dropping height

The striker mass and the dropping height shall be chosen to meet the equation:

$$m \cdot h = \frac{1\,000 E}{g}$$

where

m is the mass of the striker, in kilograms;

h is the dropping height, in millimetres;

E is as defined in 8.2.1;

g is the gravitational acceleration (9,8 m/s²).

However the mass of the striker shall be equal to the force $W \pm 10$ daN.

8.3 Test procedure

Fit the smallest tyre compatible with the design load of the wheel and mount the combination on the support according to the method used to attach the wheel to the vehicle. The relative position shall be so determined that at the moment of the impact the speed vector passes through the centre of the wheel (see figure 3).

Determine the tyre inflation pressure, the striker mass and dropping height in accordance with 8.2.

9 Torsion test

9.1 Test equipment

The test equipment shall permit a torsional moment to be applied between the hub and the rim. Figure 4 shows an example of such equipment.

9.2 Test conditions

The torsional moment, T , in decanewton metres, applied as in 9.3, shall be determined by the equation:

$$T = \pm W \cdot r$$

where W and r are as defined in 6.2.1.

9.3 Test procedure

Fix the flange of the wheel rim to the support [see figure 4a)], and apply the torsional moment, determined according to 9.2, repeatedly through the contact face of the hub. The length of the loading arm shall be equal to the radius of the smallest tyre suitable for the wheel.

It is also permissible to fix the wheel to the support through the contact face of the hub and apply the torsional moment to the wheel rim by means of an annular ring rigidly attached to the rim [see figure 4b)].

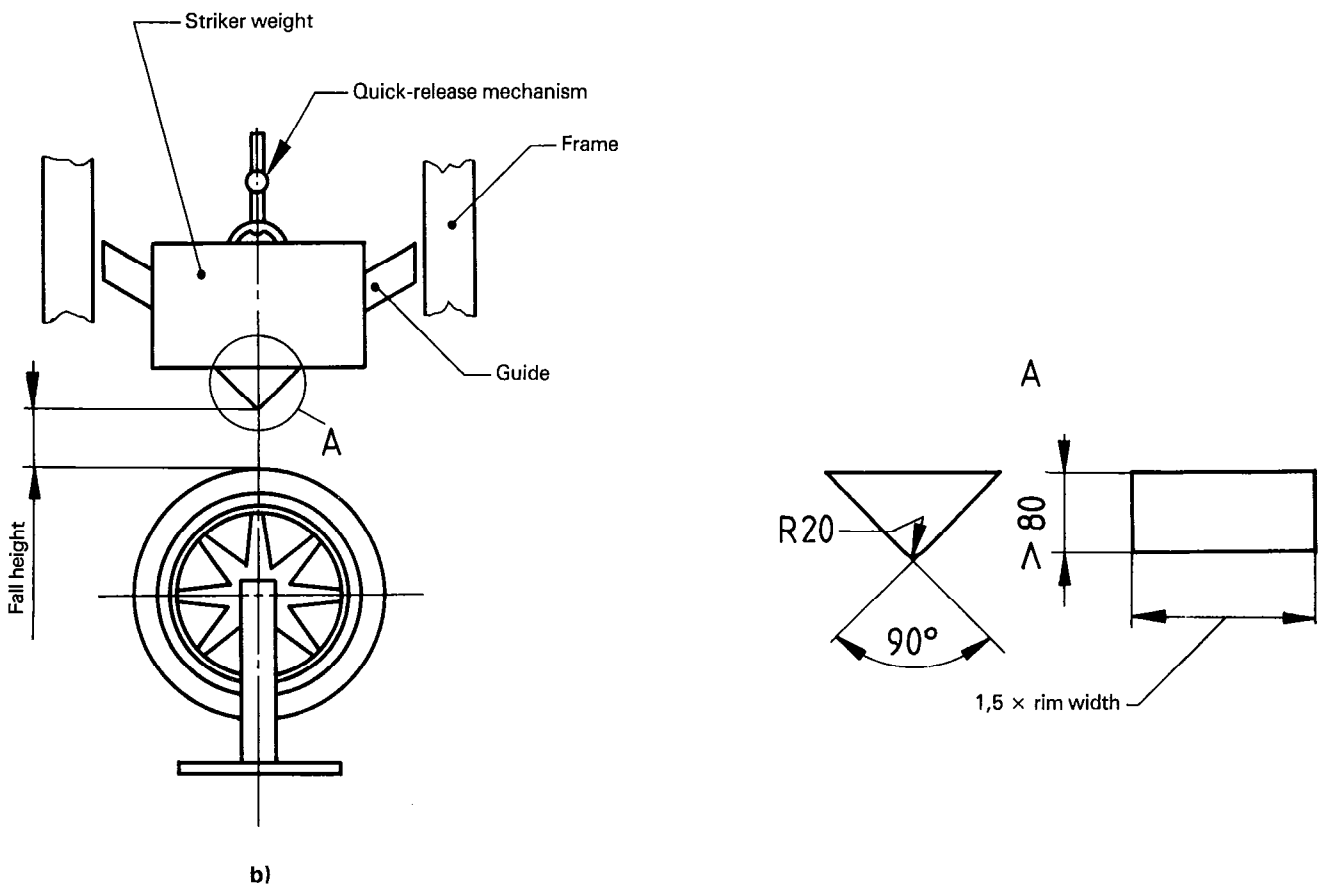
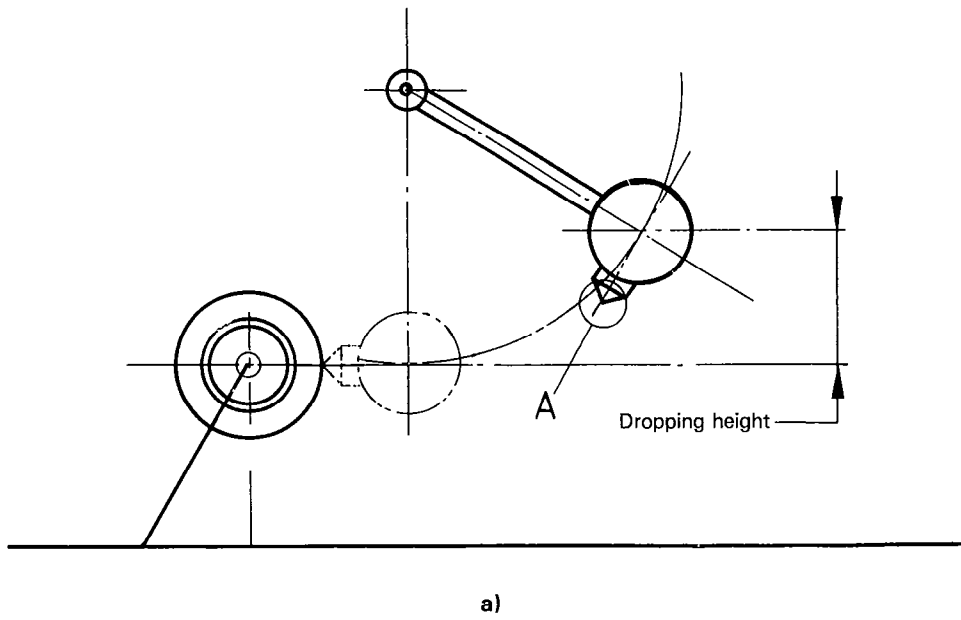

Figure 3 – Model equipment for radial impact resistance test

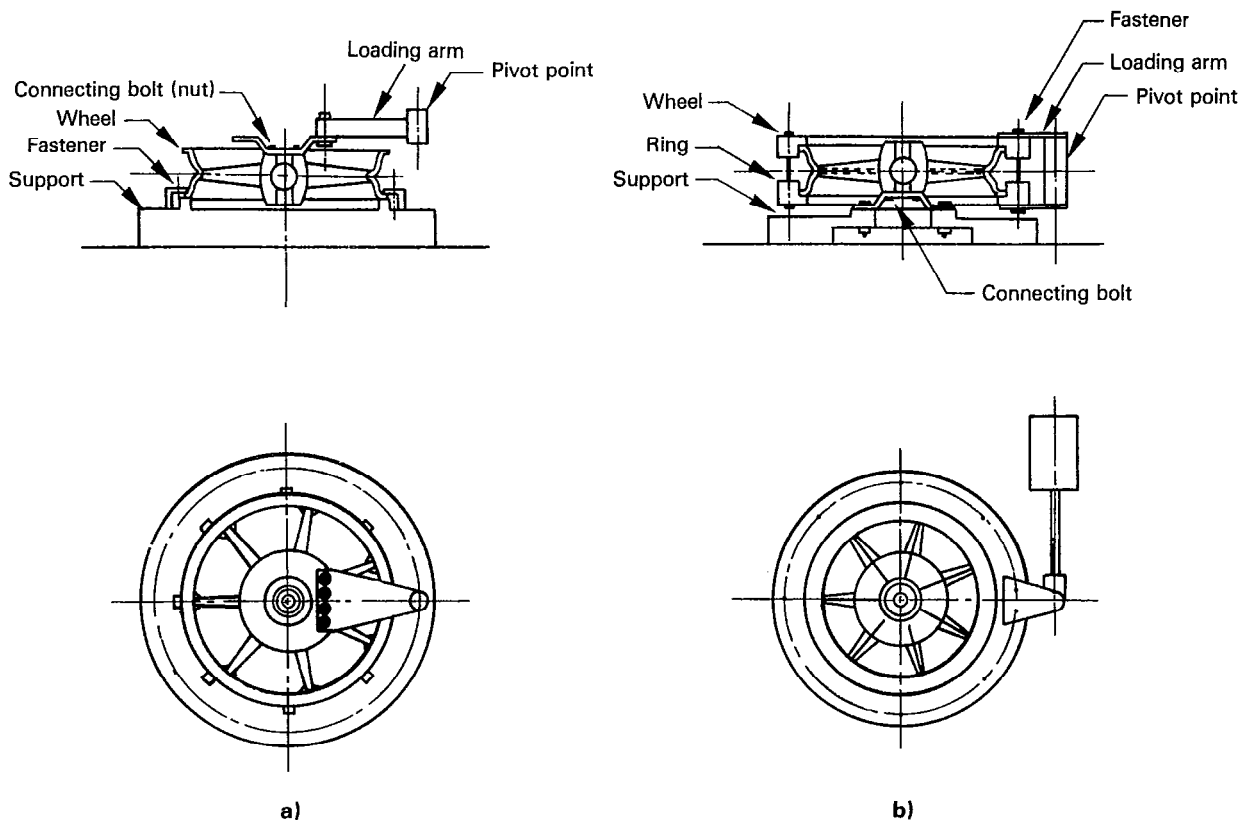

Figure 4 — Model equipment for torsion test

10 Air leak test (applicable only to wheels designed and marked for use with tubeless tyres)

10.1 Test equipment

Figure 5 shows an example of test equipment suitable for the test given in 10.3.

10.2 Test conditions

The air pressure to be applied in accordance with 10.3.1 shall be over 300 kPa.

10.3 Test procedure

10.3.1 Tightly close both sides of the flange by the presser plates (see figure 5) and supply the pressurized air as indicated in 10.2 to the inside of the wheel in order to confirm the airtightness of the rim.

10.3.2 Alternatively, for rims of divided construction where sealing rings are used, the rim may be fitted with a tyre, the tyre inflated and the whole assembly immersed in water.

11 Performance

11.1 Durability against bending moment

After being subjected to at least 10^5 cycles, or 10^6 cycles in the case of reinforced wheels, according to the test specified in clause 6, there shall be no evidence of harmful cracks, significant deformation or any abnormal looseness at joints.

Reinforced wheels shall be used for three-wheeled vehicles specifically designed to carry goods and such wheels shall be marked with the letters "HD" after the marking for dimension and maximum design load.

11.2 Durability against radial load

After being subjected to at least 5×10^5 cycles of the test in clause 7, there shall be no evidence of harmful cracks, significant deformation, or any abnormal looseness at joints.

11.3 Impact resistance

After being subjected to the impact in clause 8, there shall be no evidence of harmful cracks, significant deformation, abnormal looseness at joints, or any sudden air leakage due to failure of the rim. 1)

1) Sudden air leakage shall be a case where the test pressure drops by more than 50 % in less than 30 s.

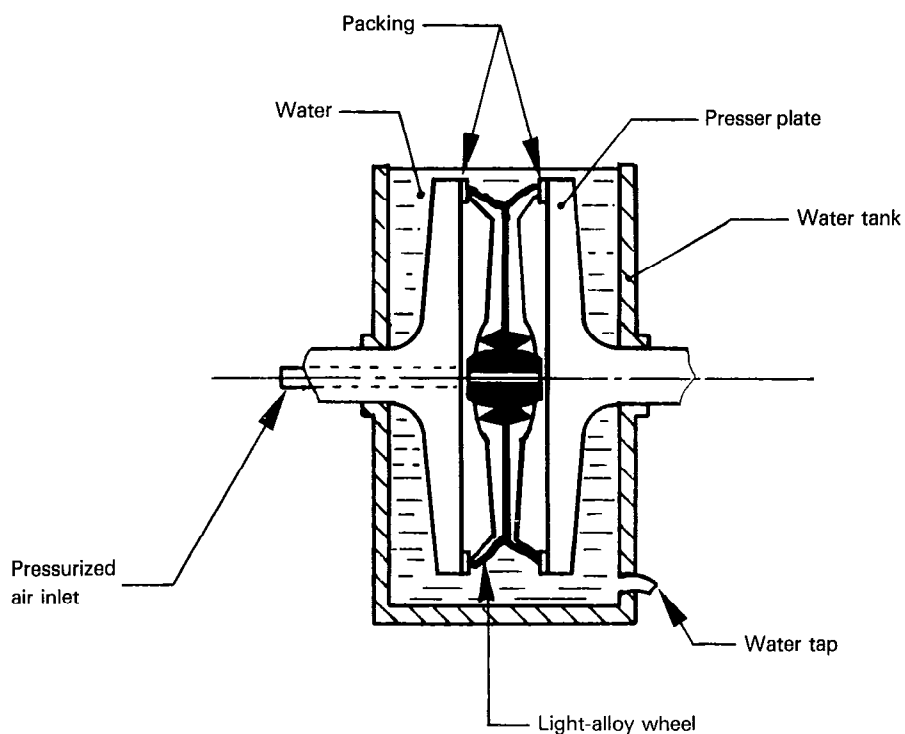

Figure 5 — Model equipment for air leak test

11.4 Durability against torsional moment

After being subjected to at least 10^5 cycles of the test in clause 9, there shall be no evidence of harmful cracks, significant deformation, or any abnormal looseness at joints.

11.5 Airtightness of rims

There shall be no leakage of air as indicated by bubbles through the rim of the wheel after application of the test pressure in accordance with clause 10 for a minimum period of 2 min.

UDC 629.118.35.012.332 : 669.7.018

Descriptors : road vehicles, mopeds, vehicle wheels, tests, performance tests.

Price based on 6 pages
