

INTERNATIONAL STANDARD

ISO
8580

First edition
1987-12-15



INTERNATIONAL ORGANIZATION FOR STANDARDIZATION
ORGANISATION INTERNATIONALE DE NORMALISATION
МЕЖДУНАРОДНАЯ ОРГАНИЗАЦИЯ ПО СТАНДАРТИЗАЦИИ

Rubber and plastics hoses — Determination of ultra-violet resistance under static conditions

*Tuyaux en caoutchouc et en plastique — Détermination de la résistance aux ultraviolets dans
des conditions statiques*

Reference number
ISO 8580:1987 (E)

Foreword

ISO (the International Organization for Standardization) is a worldwide federation of national standards bodies (ISO member bodies). The work of preparing International Standards is normally carried out through ISO technical committees. Each member body interested in a subject for which a technical committee has been established has the right to be represented on that committee. International organizations, governmental and non-governmental, in liaison with ISO, also take part in the work.

Draft International Standards adopted by the technical committees are circulated to the member bodies for approval before their acceptance as International Standards by the ISO Council. They are approved in accordance with ISO procedures requiring at least 75 % approval by the member bodies voting.

International Standard ISO 8580 was prepared by Technical Committee ISO/TC 45, *Rubber and rubber products*.

Users should note that all International Standards undergo revision from time to time and that any reference made herein to any other International Standard implies its latest edition, unless otherwise stated.

Rubber and plastics hoses — Determination of ultra-violet resistance under static conditions

0 Introduction

The test method described in this International Standard provides a means of assessing the resistance of hoses to the deleterious effects of ultra-violet light under static conditions.

1 Scope and field of application

This International Standard specifies three methods for determining the resistance of the outer cover of hoses to ultra-violet light :

Method 1 : for bore sizes up to and including 25 mm, the test being carried out on the hose itself;

Method 2 : for bore sizes greater than 25 mm, the test being carried out on a test piece from the hose wall;

Method 3 : for bore sizes greater than 25 mm, the test being carried out on a test piece from the hose cover.

Method 1 or 2 should normally be used. Method 3 should be used only if it is not possible to carry out the test in accordance with Method 2.

2 References

ISO 291, *Plastics — Standard atmospheres for conditioning and testing.*

ISO 471, *Rubber — Standard temperatures, humidities and times for the conditioning and testing of test pieces.*

ISO 4892, *Plastics — Methods of exposure to laboratory light sources.*

3 Apparatus

3.1 Test cabinet containing an array of fluorescent tube lamps as described in ISO 4892, annex D, to cover the test piece and the test piece holder. The cabinet shall be fitted with temperature and humidity controls to maintain a constant environment of between 50 and 80 °C to an accuracy of ± 3 °C and 35 % to 90 % relative humidity to an accuracy of ± 5 %.

NOTE — Most ultra-violet irradiation sources have a limited life after which the intensity of the radiation decreases. Care should be taken to ensure that the life of operation of the fluorescent lamp is recorded and that the unit is rotated in accordance with ISO 4892, annex D, subclause D.3.1, and is replaced after the useful life has expired.

All apparatus placed in the test cabinet shall be fabricated from materials which do not absorb or react to ultra-violet light.

3.2 Test piece holder, as shown in figure 1, for Method 1.

3.3 Test piece holder, as shown in figure 2, for Method 2.

3.4 Test piece holder, as shown in figure 3, for Method 3.

4 Test pieces

4.1 Type of test piece

4.1.1 Method 1

The test piece shall consist of a sample of hose. The length shall be calculated from the equation

$$L = \pi \left(\frac{D}{2} + d \right) + 2d$$

where

L is the length of the test piece;

D is the diameter of the mandrel (see figure 1) necessary to produce the required elongation of the test piece (see clause 6), the elongation being measured over a minimum length of $10d$;

d is the outside diameter of the hose under test.

4.1.2 Method 2

The test piece shall consist of a strip cut longitudinally from the hose. The strip shall be 150 mm long and 25 mm wide.

4.1.3 Method 3

The test piece shall consist of a strip of the hose cover, removed longitudinally from the hose. The strip shall be 100 mm long and 25 mm wide.

4.2 Number of test pieces

Two test pieces shall be tested.

5 Conditioning of test pieces

Prior to testing, condition the test pieces, mounted as described in clause 7, at the applicable standard condition as specified in ISO 471 or ISO 291 as appropriate, in darkness or subdued light.

6 Test conditions

Unless other conditions are specified in the relevant hose specification, expose the test piece under test to ultra-violet light with a wavelength of 290 to 400 nm at an irradiance level of $50 \text{ W/m}^2 \pm 5 \%$, at a temperature of $70 \pm 3 \text{ }^\circ\text{C}$ and a relative humidity of 50 % to 55 % for $500 \pm 4 \text{ h}$.

Unless otherwise specified in the relevant hose specification, the elongation of the test piece shall be $20 \pm 10 \%$.

7 Procedure

7.1 Method 1

7.1.1 Mount the test piece as shown in figure 1.

7.1.2 Adjust the atmosphere within the test cabinet to $70 \pm 3 \text{ }^\circ\text{C}$ and 50 % to 55 % relative humidity.

7.1.3 Place the assembly in the test cabinet and expose it to the effects of the irradiation source for $500 \pm 4 \text{ h}$.

7.1.4 Remove the mandrel and test piece from the test cabinet. Remove the test piece from the test mandrel and straighten the hose into its natural position. Replace the test piece on the test mandrel and examine the surface of the test piece under X 2 magnification. Record the nature and position of any cracking or change in colour or appearance observed.

7.2 Method 2

7.2.1 Mount the test piece in a test piece holder as shown in figure 2, place the assembly in the test cabinet and expose it to the effects of the irradiation source for $500 \pm 4 \text{ h}$.

7.2.2 Remove the test piece holder and test piece from the test cabinet. Remove the test piece from the test piece holder and straighten the test piece into its natural position. Replace the test piece in the test piece holder and examine the surface of the test piece under X 2 magnification. Record the nature and position of any cracking or change in colour or appearance observed.

7.3 Method 3

7.3.1 Mount the test piece in the test piece holder (see figure 3) in the test cabinet, apply the appropriate elongation and expose it to the effects of the irradiation source for $500 \pm 4 \text{ h}$.

7.3.2 Remove the test piece holder and the test piece from the test cabinet. Remove the test piece from the test piece holder and allow the test piece to return to its natural length for 1 min. Replace the test piece in the test piece holder, apply the appropriate elongation and examine the surface of the test piece under X 2 magnification. Record the nature and position of any cracking or change in colour or appearance observed.

8 Test report

The test report shall include the following information :

- a) full description of the hose tested;
- b) a reference to this International Standard;
- c) the test method used (1, 2 or 3);
- d) the details of the test conditions;
- e) extent and position of cracking;
- f) change in colour and appearance;
- g) date of test.

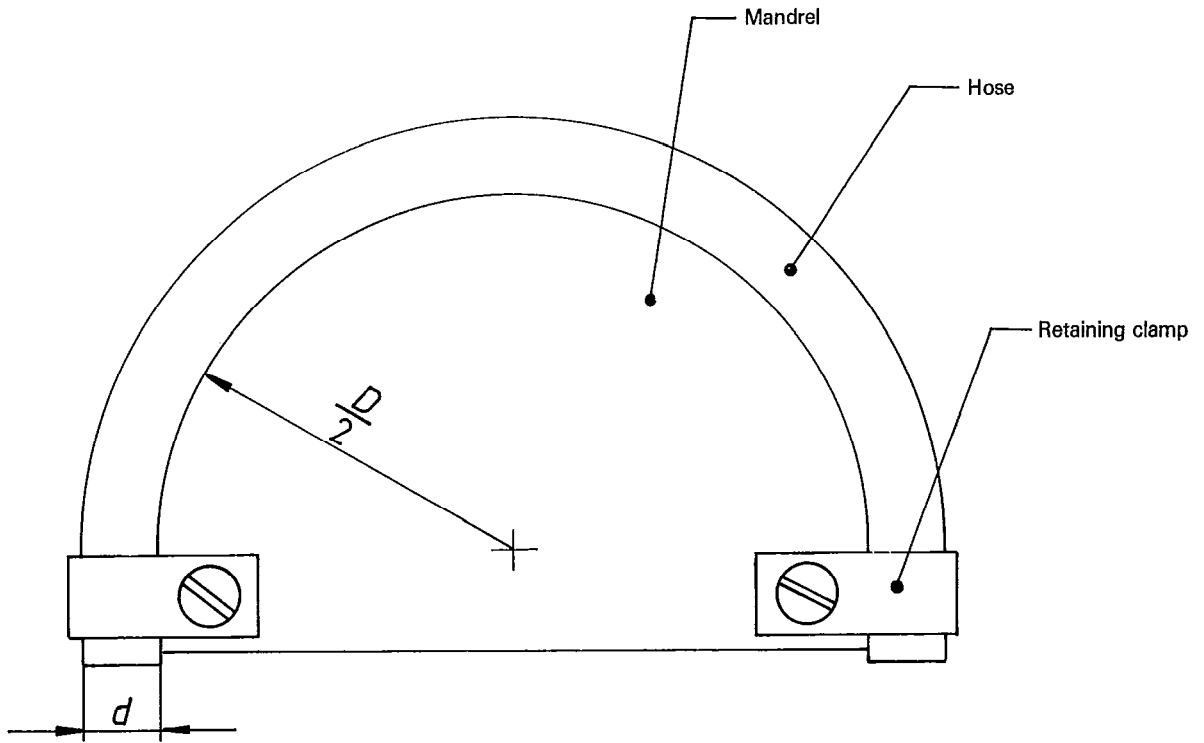

Figure 1 — Arrangement for mounting hose on mandrel for Method 1

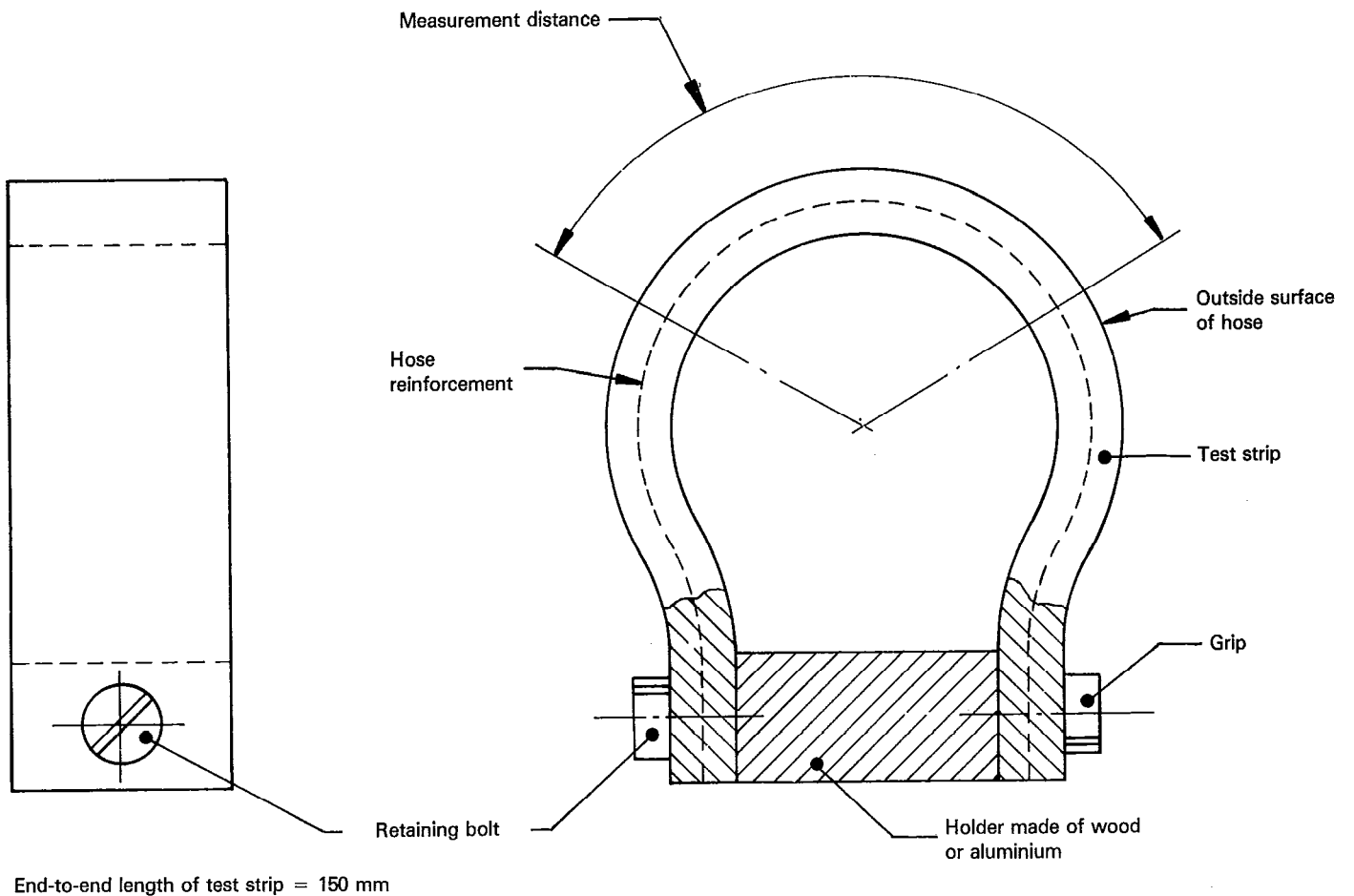
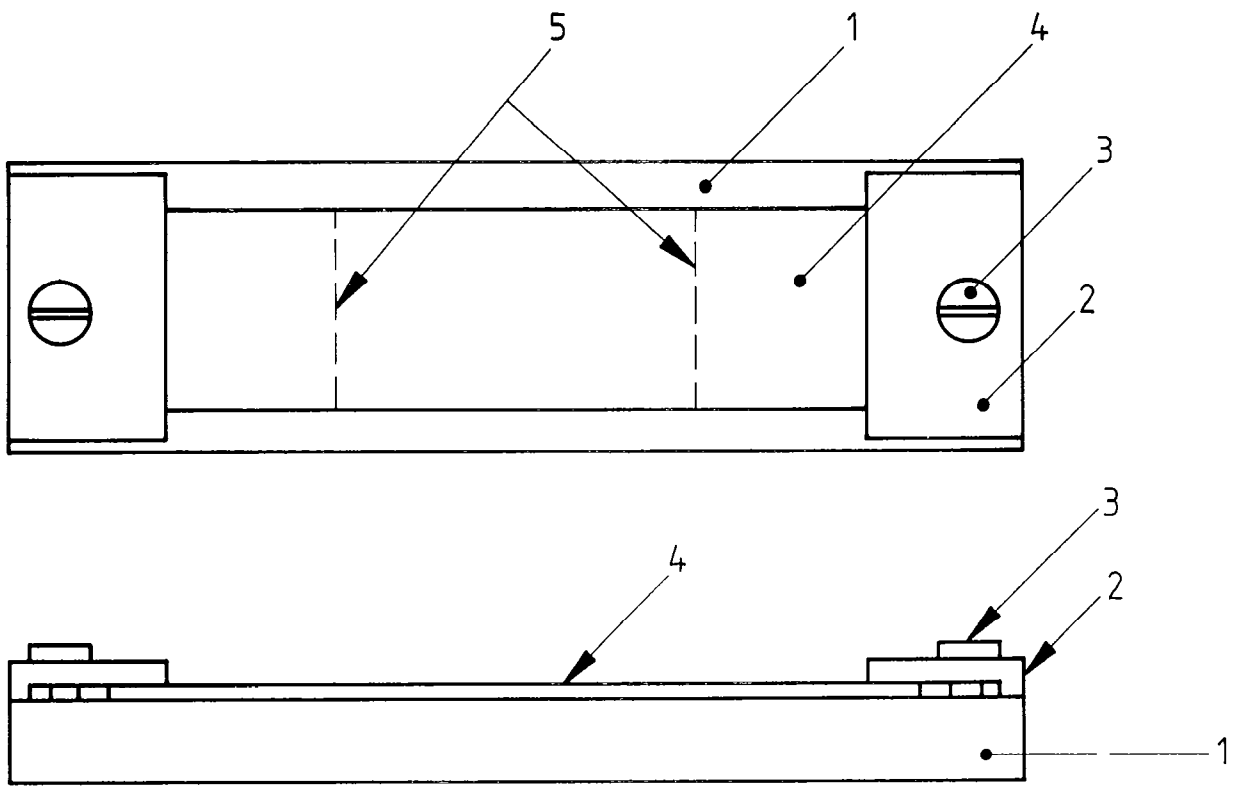

Figure 2 — Test piece holder for Method 2



- 1 Holder made of wood or aluminium
- 2 Clamp
- 3 Retaining bolt
- 4 Test piece
- 5 Marking for extension measurement

Figure 3 — Test piece holder for Method 3

ISO 8580 : 1987 (E)

UDC 621.643.3-036 : 620.193.6 : 535-31

Descriptors : rubber products, plastics products, hoses, tests, ultraviolet radiation tests.

Price based on 4 pages
