

INTERNATIONAL STANDARD

ISO 8573-9

First edition
2004-02-01

Compressed air —

Part 9:

Test methods for liquid water content

Air comprimé —

*Partie 9: Méthodes d'essai pour la détermination de la teneur en eau
liquide*



Reference number
ISO 8573-9:2004(E)

© ISO 2004

PDF disclaimer

This PDF file may contain embedded typefaces. In accordance with Adobe's licensing policy, this file may be printed or viewed but shall not be edited unless the typefaces which are embedded are licensed to and installed on the computer performing the editing. In downloading this file, parties accept therein the responsibility of not infringing Adobe's licensing policy. The ISO Central Secretariat accepts no liability in this area.

Adobe is a trademark of Adobe Systems Incorporated.

Details of the software products used to create this PDF file can be found in the General Info relative to the file; the PDF-creation parameters were optimized for printing. Every care has been taken to ensure that the file is suitable for use by ISO member bodies. In the unlikely event that a problem relating to it is found, please inform the Central Secretariat at the address given below.

© ISO 2004

All rights reserved. Unless otherwise specified, no part of this publication may be reproduced or utilized in any form or by any means, electronic or mechanical, including photocopying and microfilm, without permission in writing from either ISO at the address below or ISO's member body in the country of the requester.

ISO copyright office
Case postale 56 • CH-1211 Geneva 20
Tel. + 41 22 749 01 11
Fax + 41 22 749 09 47
E-mail copyright@iso.org
Web www.iso.org

Published in Switzerland

Contents

Page

Foreword	iv
Introduction	v
1 Scope	1
2 Normative references	1
3 Terms and definitions	1
4 Units and symbols	2
5 Selection of methods	2
6 Sampling techniques	2
7 Measurement methods	2
8 Evaluation of test results	8
9 Uncertainty	9
10 Test report	9
Annex A (informative) Sample test report	11

Foreword

ISO (the International Organization for Standardization) is a worldwide federation of national standards bodies (ISO member bodies). The work of preparing International Standards is normally carried out through ISO technical committees. Each member body interested in a subject for which a technical committee has been established has the right to be represented on that committee. International organizations, governmental and non-governmental, in liaison with ISO, also take part in the work. ISO collaborates closely with the International Electrotechnical Commission (IEC) on all matters of electrotechnical standardization.

International Standards are drafted in accordance with the rules given in the ISO/IEC Directives, Part 2.

The main task of technical committees is to prepare International Standards. Draft International Standards adopted by the technical committees are circulated to the member bodies for voting. Publication as an International Standard requires approval by at least 75 % of the member bodies casting a vote.

Attention is drawn to the possibility that some of the elements of this document may be the subject of patent rights. ISO shall not be held responsible for identifying any or all such patent rights.

ISO 8573-9 was prepared by Technical Committee ISO/TC 118, *Compressors, pneumatic tools and pneumatic machines*, Subcommittee SC 4, *Quality of compressed air*.

ISO 8573 consists of the following parts, under the general title *Compressed air*:

- *Part 1: Contaminants and purity classes*
- *Part 2: Test methods for aerosol oil content*
- *Part 3: Test methods for measurement of humidity*
- *Part 4: Test methods for solid particle content*
- *Part 5: Test methods for oil vapour and organic solvent content*
- *Part 6: Test methods for gaseous contaminant content*
- *Part 7: Test methods for viable microbiological contaminant content*
- *Part 8: Test methods for solid particle content by mass concentration*
- *Part 9: Test methods for liquid water content*

Part 2 is under revision.

Introduction

Water can be present in compressed air systems in two states: liquid and vapour. Liquid water usually consists of liquid aerosol and wall flow.

This part of ISO 8573 deals with liquid water content. Water vapour content is dealt with in ISO 8573-3.

© ISO 2004. All rights reserved.

1

Compressed air —

Part 9: Test methods for liquid water content

1 Scope

This part of ISO 8573 specifies test methods for determining the liquid water content in compressed air, expressed as the liquid water mass concentration. The limitations of the methods are also given. One of a series of standards aimed at harmonizing air contamination measurements, it identifies sampling techniques and also gives requirements for evaluation, uncertainty considerations and reporting for the air purity parameter liquid water. The test methods are suitable for determining the purity classes in accordance with ISO 8573-1.

2 Normative references

The following referenced documents are indispensable for the application of this document. For dated references, only the edition cited applies. For undated references, the latest edition of the referenced document (including any amendments) applies.

ISO 1219-1, *Fluid power systems and components — Graphic symbols and circuit diagrams — Part 1: Graphic symbols*

ISO 3857-1, *Compressors, pneumatic tools and machines — Vocabulary — Part 1: General*

ISO 5598, *Fluid power systems and components — Vocabulary*

ISO 8573-1, *Compressed air — Part 1: Contaminants and purity classes*

ISO 8573-2, *Compressed air — Part 2: Test methods for aerosol oil content*

ISO 8573-3, *Compressed air — Part 3: Test methods for measurement of humidity*

3 Terms and definitions

For the purposes of this document, the terms and definitions given in ISO 3857-1, ISO 5598, ISO 8573-1, ISO 8573-2 and the following apply.

3.1

water aerosol

liquid water particles in compressed air that have negligible fall velocity/settling velocity

3.2

liquid water

water aerosol and wall flow in compressed air

4 Units and symbols

For the purposes of this part of ISO 8573, the following, including non-SI-preferred, units are used:

- 1 bar = 100 000 Pa;
- 1 l (litre) = 0,001 m³;
- bar(a) is used for expressing absolute pressure;
- bar(e) is used for expressing effective pressure.

For the graphic symbols used in Figure 1, diagrams are in accordance with ISO 1219-1.

5 Selection of methods

The method to be selected is dependent on the mass concentration range of liquid water in compressed air. The most suitable method for the range of liquid water content estimated to be present in the sample may be selected from Table 1.

Table 1 — Liquid water mass concentration measurement methods

Type of method	Liquid water concentration (c_w) g/m ³
Gravimetric method	$c_w \geq 0,1$
Vapourization method	$c_w \leq 5$

6 Sampling techniques

The sampling shall be made at or near actual pressure and at a constant compressed air flow rate.

The choice of sampling method will depend upon the actual level of contamination and the compressed air flow in the compressed air system. For sampling methods, see ISO 8573-2.

Compressed air samples may be routed back into main pipe or vent to the atmosphere after measurement. The value of air sample parameters (pressure, temperature, air velocity, etc.) shall be within the ranges specified by the test equipment manufacturer.

7 Measurement methods

7.1 General

The test equipment and instruments shall be in good working order. Consideration shall be given to the calibration requirements of the measurement equipment used as given in the applicable instructions.

Pressure and temperature may also affect liquid water content measurement results. Therefore, the temperature and the pressure at the measuring point should be maintained at steady state conditions.

Reference should be made to the measurement equipment manufacturer as to applicability of the equipment.

7.2 Determination of liquid water content by gravimetric method

7.2.1 General

This method identifies the collection of condensate from the sampling point, the separation of water from that condensate and the weight of liquid water present in the compressed air sample. The volume of compressed air from which the liquid water is separated shall be measured.

7.2.2 Test equipment

7.2.2.1 General description

The general arrangement of the test equipment for the gravimetric method shall be in accordance with Figure 1. In the case of partial flow sampling, the water separator (3) with the attendant components (12 and 13) in the drain line should be excluded.

NOTE The numbers given between parentheses refer to the numbering of the elements in Figure 1.

For symbols, see ISO 1219-1.

7.2.2.2 Water separator (3)

The main function of the separator is partial removal of liquid water from air flow and protection of the high-efficiency filter (4) from overflow. The separator efficiency of water removal from the compressed air flow shall be not less than 80 %.

7.2.2.3 High-efficiency filter (4)

The high-efficiency coalescing filter for liquid water removal shall have an efficiency of $\geq 99,9$ %, rated for oil particles ≤ 3 μm .

7.2.2.4 Collecting vessels (13)

Vessels with a volume of not less than 0,5 l that enable the liquid water collection to be observed during testing shall be used.

7.2.2.5 Oil/water separator (14)

The liquid collected in the collecting vessels (13) shall be transferred to the oil/water separator (14). A detailed explanation of the procedure of water separation is identified in ISO 8573-2.

7.2.2.6 Drain valves (12)

Drain valves are used to drain the liquid water collected in the water separator (3), high-efficiency filter (4) and collecting vessels (13). A drain valve between the filter (4) and the collecting vessel is normally left in the open position; a drain valve between the collecting vessel and the oil/water separator (14) is normally left in the closed position.

7.2.2.7 Measuring columns (15)

The amount of separated liquid water is measured in the measuring column graduated in millilitres or weighted in grams. The accuracy of measurement of mass shall be better than ± 2 % of the reading.

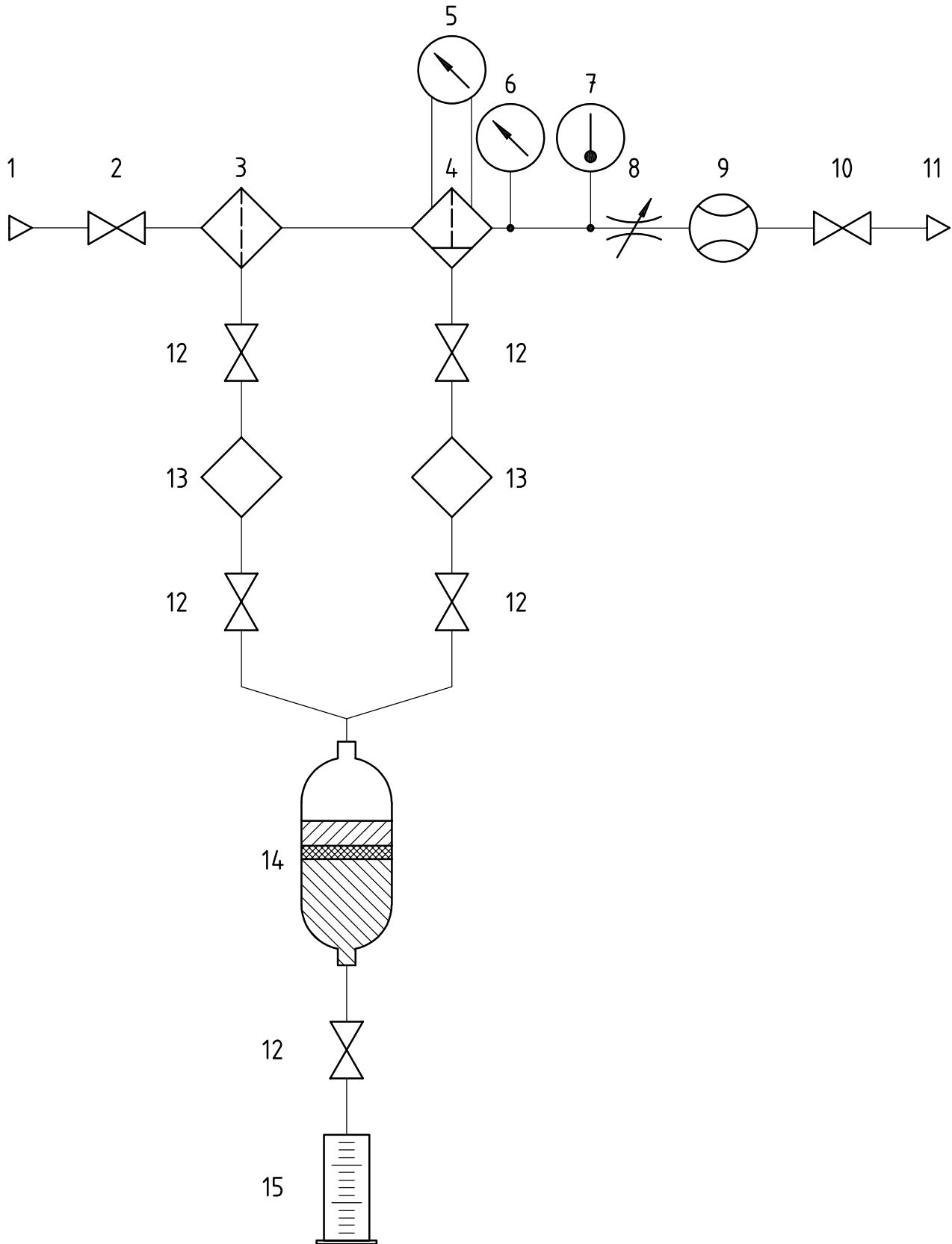

Key

- | | | | | | |
|---|-----------------------------|----|--------------------|----|---------------------|
| 1 | sampling point | 6 | pressure gauge | 11 | discharge outlet |
| 2 | shut-off valve | 7 | thermometer | 12 | drain valve |
| 3 | water separator | 8 | flow control valve | 13 | collecting vessel |
| 4 | high-efficiency filter | 9 | air flowmeter | 14 | oil/water separator |
| 5 | differential pressure gauge | 10 | shut-off valve | 15 | measuring column |

Figure 1 — Circuit diagram of test equipment for weighing method

7.2.2.8 Differential pressure gauge (5)

This gauge determines the pressure drop across the high-efficiency filter (4). The accuracy of measurement of the pressure drop shall be better than $\pm 2\%$.

7.2.2.9 Pressure gauge (6)

In order to determine the air sample volume, the values of pressure shall be recorded during the entire period of the test. The accuracy of measurement of pressure shall be better than $\pm 2\%$ of full scale.

7.2.2.10 Thermometer (7)

In order to determine the air sample volume, the values of temperature shall be recorded during the entire period of the test. The accuracy of measurement of temperature shall be better than $\pm 1\text{ }^\circ\text{C}$.

7.2.2.11 Air flowmeter (9)

In order to determine the air sample volume, the values of flow rate shall be recorded during the entire period of the test. The accuracy of measurement of flow rate shall be better than $\pm 5\%$.

7.2.2.12 Flow control valve (8)

In order to adjust the flow accurately, a flow control valve with fine adjustment shall be used.

7.2.2.13 Pipes, connectors, shut-off valves (2,10 and 12)

Pipes, connectors and shut-off valves shall be according to ISO 8573-2.

7.2.3 Test procedure

The procedures for preparation for measuring the high-efficiency filter (4) stabilization and the liquid water measurement shall be carried out in accordance with ISO 8573-2.

In order to obtain good test uncertainty, the air sampling shall be carried on until the appearance in the collecting vessels (13) of not less than 100 ml of total liquid water as a sum of both vessels.

7.2.4 Determination of test results

It is necessary to ensure that result are stable, repeatable and presented in a form which shows that they are so.

When the volume of liquid water is measured, the liquid water content in the compressed air flow, c_w , in g/m^3 , is calculated using the following formula:

$$c_w = \frac{V\rho}{qt} \times \frac{1}{60} = 0,016\ 67 \frac{V\rho}{qt} \quad (1)$$

where

V is the volume of liquid water collected, in millilitres;

ρ is the specific density of water, in kilograms per cubic metre;

q is the sampling air flow rate, in litres per second (ANR);

t is the duration of the test, in minutes.

When the mass of liquid water is measured, the formula becomes:

$$c_w = \frac{m}{qt} \times \frac{1\,000}{60} = 16,667 \frac{m}{qt} \quad (2)$$

where

m is the mass of water, in grams.

7.3 Determination of liquid water content by vapourization method

7.3.1 General

The vapourization method consists of the following consecutive operations:

- a) determination of the water vapour quantity in the compressed air sample under actual conditions (for the full saturation state);
- b) changing the compressed air sample parameters to transform the liquid water to vapour;
- c) determination of the water vapour quantity in the compressed air sample after changing its parameters;
- d) determination of the difference between water vapour content values in the compressed air sample in actual conditions and after the transformation of liquid water to vapour.

The vapourization method may be used in conjunction with either the full or partial flow sampling method.

7.3.2 Test equipment

7.3.2.1 General description

The general arrangement of the test equipment for vapourization shall be in accordance with Figure 2.

NOTE The numbers between parentheses in the subclause titles refer to the numbering of the elements in Figure 2.

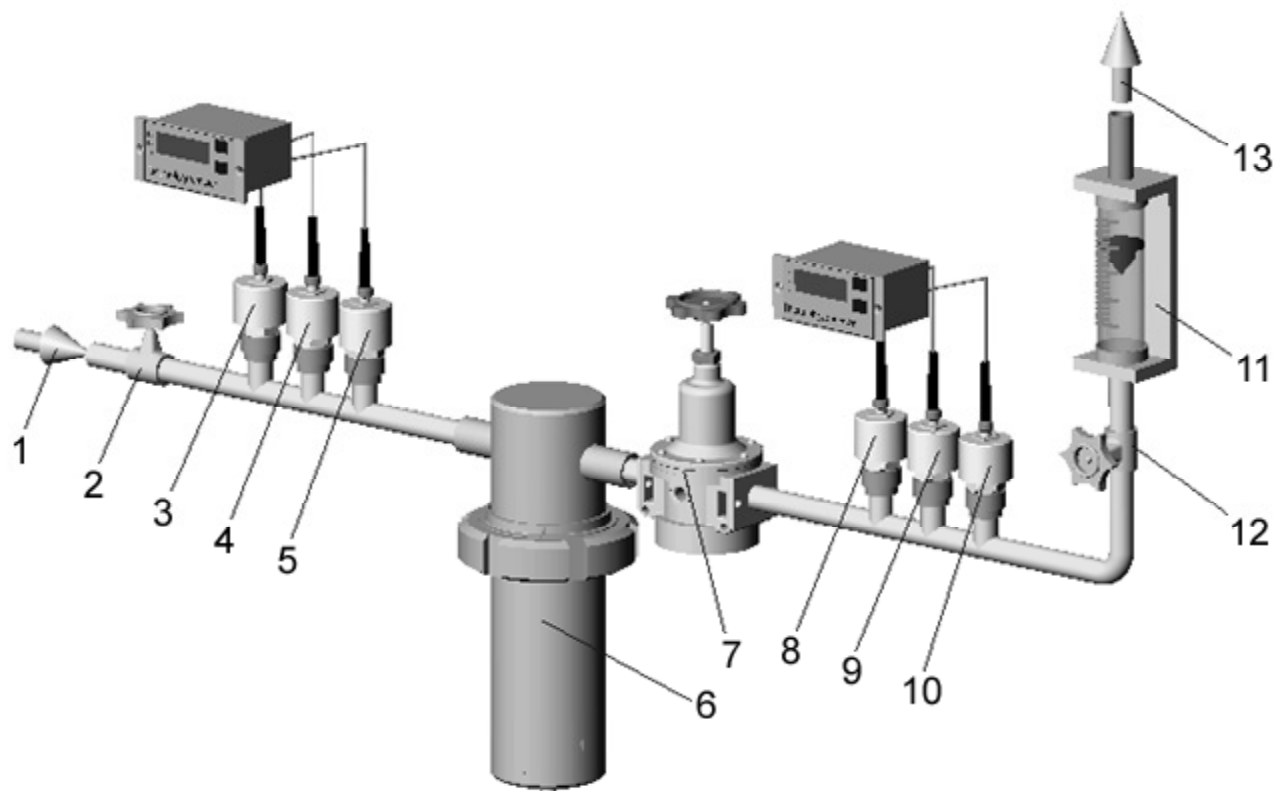

Key

- | | | | |
|---|--------------------------|----|-----------------------------|
| 1 | sampling point | 8 | pressure sensor |
| 2 | shut-off valve | 9 | temperature sensor |
| 3 | pressure sensor | 10 | humidity sensor |
| 4 | temperature sensor | 11 | flowmeter or flow indicator |
| 5 | humidity sensor | 12 | flow control valve |
| 6 | heater | 13 | discharge outlet |
| 7 | pressure regulator valve | | |

Figure 2 — Set-up for vapourization method

7.3.2.2 Pressure sensor (3 and 8)

These instruments are required for the measurement of the compressed air pressure under actual conditions and after the vapourization of the liquid water during the entire test period. The accuracy of measurement of the pressure shall be better than $\pm 2\%$ of reading.

7.3.2.3 Temperature sensor (4 and 9)

These instruments are required for the measurement of the compressed air temperature under actual conditions and after the vapourization of the liquid water during the entire test period. The accuracy of measurement of the temperature shall be better than $\pm 1\text{ }^{\circ}\text{C}$ of reading.

7.3.2.4 Humidity sensor (5 and 10)

These instruments are required for the measurement of the compressed air humidity under actual conditions and after the vapourization of the liquid water during the entire test period. The accuracy of measurement of the humidity shall be better than $\pm 5\%$ RH.

7.3.2.5 Heater (6)

The heater shall be powerful enough to transform all liquid water to vapour.

7.3.2.6 Pressure regulator valve (7)

The pressure regulator valve shall reduce the compressed air pressure to intensify the liquid water vapourization.

In order to obtain good test uncertainty, the heater (6) and the flow control valve (12) shall guarantee the downstream level of compressed air relative humidity at not more than 80 %.

7.3.2.7 Flowmeter or flow indicator (11)

In order to determine the availability of the air sample flow, a flowmeter or flow indicator shall be used.

7.3.2.8 Pipes, connectors, shut-off valve (2) and flow control valve (12)

Pipes, connectors and shut-off valve and flow control valve shall be according to ISO 8573-2.

7.3.3 Calculation of test results

The value of the liquid water content, c_w in g/m^3 , is determined using the formula:

$$c_w = d_2 - d_1 \quad (3)$$

where

d_1 is the water vapour content in the air sample under actual conditions, in grams per cubic metre;

d_2 is the water vapour content in the air sample after the transformation of liquid water to vapour, in grams per cubic metre.

The measurement of the water vapour content d_1 and d_2 shall be made in accordance with ISO 8573-3.

Taking into consideration the fact that the compressed air sample is fully saturated under actual conditions (i.e. relative humidity is 100 %), water vapour content d_1 can also be determined using the table of limited content of water vapour in air or the "i-d" diagram of wet air state.

8 Evaluation of test results

8.1 Reference conditions

The measured liquid water content shall be recalculated to refer to the dry air volume as given by the partial pressure of the air at the sampling point.

Reference conditions for liquid water content volume statements are as follows.

- Air temperature: 20 °C;
- Air pressure: 1 bar(a);
- Relative water vapour pressure: 0 %.

8.2 Average value

Depending on the reproducibility of the method, the measurement facility and the experience of the parties involved in the provision of the measurement facility, the average of consecutive measurements at the sample point shall be used.

9 Uncertainty

The uncertainty of the method depends on the equipment used and accuracy of the result calculation. The total uncertainty of the authorized results of the test shall be $\pm 10\%$.

NOTE The uncertainty of the vapourization method for liquid water content measurement depends on the hygrometer used and the accuracy of calculation.

10 Test report

10.1 Statements

Statements of the liquid water content in the compressed air shall be made such that the values can be verified according to the procedures given in this part of ISO 8573.

The influence of any factors — e.g. oil contaminants or sample pipe — present in the sample that may affect the result of liquid water measurement shall be recorded.

10.2 Statement format

The report used to declare liquid water content according to this part of ISO 8573 shall contain the following.

- a) A description of the compressed air system and its working conditions, with sufficient detail for determining the validity of the declared concentration value:
 - 1) volume flow rate;
 - 2) sampling time;
 - 3) pressure;
 - 4) temperature;
 - 5) other contaminants.
- b) A description of the sampling point where the samples were taken.
- c) A description of the sampling and measurement system used, in particular, the materials and equipment used, and details of its calibration record.
- d) The phrase “Declared liquid water content in accordance with ISO 8573-9”, followed by:
 - 1) the figure for the actual, average measured value evaluated in accordance with Clause 8, and calculated to refer to the *reference* conditions;
 - 2) the figure for the actual, average measured value evaluated in accordance with Clause 8 above, referring to the *actual* conditions;
 - 3) the liquid water content, expressed in grams per cubic metre at actual and reference conditions;

ISO 8573-9:2004(E)

- 4) the pressure and temperature (humidity) to which the measurement refers;
 - 5) the figure followed by a statement regarding the applicable uncertainty; and
 - 6) the date of the calibration record.
- e) The date of the sampling and measurements.

A sample test report is presented in Annex A.

—•••••

Annex A
(informative)

Sample test report

Liquid water content in compressed air

General description of compressed air system, test condition, sample point: _____

Test method applied: _____

Sampling method applied: _____

List of test equipment used and respective calibration dates: _____

Test results of liquid water content in accordance with ISO 8573-9

Test No.	Test date and time	Compressed air parameters			Total water volume collected ml	Liquid water concentration g/m ³	
		Temperature °C	Pressure bar	Total sample volume m ³		Actual condition	Reference condition
1							
2							
3							
...							
...							
...							
...							
Average value:							
Reported by:				Date:			
Authorized by:				Date:			
If the measurement is outside a particular range then identify as being "not measured".							

ICS 71.100.20

Price based on 11 pages