**Reciprocating internal combustion
engine driven alternating current
generating sets —**

**Part 2:
Engines**

*Groupes électrogènes à courant alternatif entraînés par moteurs
alternatifs à combustion interne —*

Partie 2: Moteurs



Reference number
ISO 8528-2:2005(E)

© ISO 2005

PDF disclaimer

This PDF file may contain embedded typefaces. In accordance with Adobe's licensing policy, this file may be printed or viewed but shall not be edited unless the typefaces which are embedded are licensed to and installed on the computer performing the editing. In downloading this file, parties accept therein the responsibility of not infringing Adobe's licensing policy. The ISO Central Secretariat accepts no liability in this area.

Adobe is a trademark of Adobe Systems Incorporated.

Details of the software products used to create this PDF file can be found in the General Info relative to the file; the PDF-creation parameters were optimized for printing. Every care has been taken to ensure that the file is suitable for use by ISO member bodies. In the unlikely event that a problem relating to it is found, please inform the Central Secretariat at the address given below.

© ISO 2005

All rights reserved. Unless otherwise specified, no part of this publication may be reproduced or utilized in any form or by any means, electronic or mechanical, including photocopying and microfilm, without permission in writing from either ISO at the address below or ISO's member body in the country of the requester.

ISO copyright office
Case postale 56 • CH-1211 Geneva 20
Tel. + 41 22 749 01 11
Fax + 41 22 749 09 47
E-mail copyright@iso.org
Web www.iso.org

Published in Switzerland

Contents

Page

Foreword.....	iv
1 Scope.....	1
2 Normative references	1
3 Symbols, terms and definitions.....	2
4 Other regulations and additional requirements.....	7
5 General characteristics	8
5.1 Power characteristics	8
5.2 Main characteristics of the RIC engine.....	8
5.3 Low-load operation	9
6 Speed characteristics	9
6.1 General	9
6.2 Types of speed governor used for generating sets	9
6.3 Use of speed governor	10
7 RIC engine load acceptance	10
7.1 General	10
7.2 Non-turbocharged RIC engines	10
7.3 Turbocharged RIC engines	10
8 Vibration and noise.....	11
8.1 Torsional vibration.....	11
8.2 Linear vibration	11
8.3 Noise.....	11
9 Heat balance	11
10 Inlet and exhaust system	11
11 Starting ability	11
12 Fuel, lubricants and coolants	12
13 Governing system values.....	12

Foreword

ISO (the International Organization for Standardization) is a worldwide federation of national standards bodies (ISO member bodies). The work of preparing International Standards is normally carried out through ISO technical committees. Each member body interested in a subject for which a technical committee has been established has the right to be represented on that committee. International organizations, governmental and non-governmental, in liaison with ISO, also take part in the work. ISO collaborates closely with the International Electrotechnical Commission (IEC) on all matters of electrotechnical standardization.

International Standards are drafted in accordance with the rules given in the ISO/IEC Directives, Part 2.

The main task of technical committees is to prepare International Standards. Draft International Standards adopted by the technical committees are circulated to the member bodies for voting. Publication as an International Standard requires approval by at least 75 % of the member bodies casting a vote.

Attention is drawn to the possibility that some of the elements of this document may be the subject of patent rights. ISO shall not be held responsible for identifying any or all such patent rights.

ISO 8528-2 was prepared by Technical Committee ISO/TC 70, *Internal combustion engines*.

This second edition cancels and replaces the first edition (ISO 8528-2:1993), which has been technically revised.

ISO 8528 consists of the following parts, under the general title *Reciprocating internal combustion engine driven alternating current generating sets*:

- *Part 1: Application, ratings and performance*
- *Part 2: Engines*
- *Part 3: Alternating current generators for generating sets*
- *Part 4: Controlgear and switchgear*
- *Part 5: Generating sets*
- *Part 6: Test methods*
- *Part 7: Technical declarations for specification and design*
- *Part 8: Requirements and tests for low-power generating sets*
- *Part 9: Measurement and evaluation of mechanical vibrations*
- *Part 10: Measurement of airborne noise by the enveloping surface method*
- *Part 11: Rotary uninterruptible power systems — Performance requirements and test methods¹⁾*
- *Part 12: Emergency power supplies to safety services*

1) Part 11 will be published as ISO/IEC 88528-11.

Reciprocating internal combustion engine driven alternating current generating sets —

Part 2: Engines

1 Scope

This part of ISO 8528 specifies the principal characteristics of a Reciprocating Internal Combustion (RIC) engine when used for alternating current (a.c.) generating set applications.

It applies to RIC engines for a.c. generating sets for land and marine use, excluding generating sets used on aircraft or to propel land vehicles and locomotives.

For some specific applications (e.g. essential hospital supplies, high rise buildings), supplementary requirements may be necessary. The provisions of this part of ISO 8528 should be regarded as the basis for establishing any supplementary requirements.

The terms which define the speed governing and speed characteristics of RIC engines are listed and explained where they apply specifically to the use of the engine for driving a.c. generators.

For other reciprocating-type prime movers (e.g. steam engines), the provisions of this part of ISO 8528 should be used as a basis for establishing these requirements.

2 Normative references

The following referenced documents are indispensable for the application of this document. For dated references, only the edition cited applies. For undated references, the latest edition of the referenced document (including any amendments) applies.

ISO 3046-1, *Reciprocating internal combustion engines — Performance — Part 1: Declarations of power, fuel and lubricating oil consumptions, and test methods — Additional requirements for engines for general use*

ISO 3046-4, *Reciprocating internal combustion engines — Performance — Part 4: Speed governing*

ISO 3046-5, *Reciprocating internal combustion engines — Performance — Part 5: Torsional vibrations*

ISO 8528-1²⁾, *Reciprocating internal combustion engine driven alternating current generating sets — Part 1: Application, ratings and performance*

ISO 8528-5²⁾, *Reciprocating internal combustion engine driven alternating current generating sets — Part 5: Generating sets*

2) ISO 8528-1 and ISO 8528-5 are under revision.

3 Symbols, terms and definitions

An explanation of the symbols and abbreviations used in this International Standard is shown in Table 1.

Table 1 — Symbols, terms and definitions

Symbol	Term	Unit	Definition
n	Engine speed	min ⁻¹	
n_r	Declared speed	min ⁻¹	Engine speed at declared power corresponding to the rated frequency of the generating set.
n_{sf}	Firing speed	min ⁻¹	Engine speed to which an engine must be accelerated from rest by the use of an external supply of energy separate from the fuel feed system before the engine becomes self-sustaining.
n_{max}	Maximum permissible speed	min ⁻¹	Speed of the engine specified by the RIC engine manufacturer which lies a safe amount below the speed limit (see Note 1 and Figure 3).
n_a	Partial-load speed	min ⁻¹	Steady-state engine speed of an engine running at a % of the declared power given by: $a = 100 \times \frac{P_a}{P_r}$ EXAMPLE: at 45 % power, $a = 45$ (see Figure 2) For $a = 45$ $n_a = n_{i,r} - \frac{P_a}{P_r} (n_{i,r} - n_r)$ $= n_{i,r} - 0,45 (n_{i,r} - n_r)$ Corresponding values of declared speed and partial-load speed are based on an unchanged speed setting.
$n_{i,r}$	Declared no-load speed	min ⁻¹	Steady-state engine speed without load at the same speed setting as for the declared speed n_r .
$n_{i,min}$	Lowest adjustable no-load speed	min ⁻¹	Lowest steady-state engine speed without load obtainable on the governor speed setting device.
$n_{i,max}$	Highest adjustable no-load speed	min ⁻¹	Highest steady-state engine speed without load obtainable on the governor speed setting device.
$n_{d,s}$	Setting speed of overspeed limiting device	min ⁻¹	Speed of the engine, the exceeding of which activates the overspeed limiting device (see Figure 3).
$n_{d,o}$	Operating speed of overspeed limiting device	min ⁻¹	Speed of the engine at which, for a given setting speed, the limiting device starts to operate (see Note 2 and Figure 3).

Table 1 (continued)

Symbol	Term	Unit	Definition
δn_s	Speed setting related range	%	Range of speed setting, expressed as a percentage of the declared speed given by: $\delta n_s = \frac{n_{i,max} - n_{i,min}}{n_r} \times 100$
Δn_s	Speed setting range	min ⁻¹	Range between the highest and lowest adjustable no-load speeds given by: $\Delta n_s = n_{i,max} - n_{i,min}$
$\Delta n_{s,do}$	Speed setting downward range	min ⁻¹	Range between the declared no-load speed and the lowest adjustable no-load speed given by: $\Delta n_{s,do} = n_{i,r} - n_{i,min}$
$\delta n_{s,do}$	Speed setting related downward range	%	Downward range of speed setting, expressed as a percentage of the declared speed given by: $\delta n_{s,do} = \frac{n_{i,r} - n_{i,min}}{n_r} \times 100$
$\Delta n_{s,up}$	Speed setting upward range	min ⁻¹	Range between the highest adjustable no-load speed and the declared no-load speed given by: $\Delta n_{s,up} = n_{i,max} - n_{i,r}$
$\delta n_{s,up}$	Speed setting related upward range	%	Upward range of speed setting, expressed as a percentage of the declared speed given by: $\delta n_{s,up} = \frac{n_{i,max} - n_{i,r}}{n_r} \times 100$
v_n	Speed setting rate of change	%·s ⁻¹	Rate of change of speed setting under remote control, expressed as a percentage of the related range of speed setting per second given by: $v_n = \frac{(n_{i,max} - n_{i,min})/n_r}{t} \times 100$
	Adjustment range	min ⁻¹	Speed range over which the overspeed limiting device may be adjusted.
δn_{st}	Speed droop	%	Difference between the declared no-load speed and the declared speed at declared power, for a fixed speed setting (see Figure 1). It is expressed as a percentage of the declared speed given by: $\delta n_{st} = \frac{n_{i,r} - n_r}{n_r} \times 100$
$\Delta \delta n_{st}$	Speed/power characteristic deviation	%	Maximum deviation from a linear speed power characteristic curve in the power range between no-load and declared power, expressed as a percentage of the declared speed (see Figure 2).
	Speed/power characteristic curve		Curve of steady-state speeds in the power range between no-load and declared power plotted against RIC engine power (see Figures 1 and 2).

Table 1 (continued)

Symbol	Term	Unit	Definition
P	Engine power	kW	
P_a	Actual engine power	kW	
P_r	Declared engine power	kW	
t_r	Response time	s	Time between activation of the overspeed limiting device and commencement of its operation.
p_{me}	Brake mean effective pressure	kPa	
V_{st}	Engine swept volume	l	

NOTE 1 The speed limit is the maximum calculated speed which the engine may sustain without risk of damage.

NOTE 2 For a given engine, the operating speed depends on the total inertia of the generating set and the design of the overspeed protection system.

NOTE 3 100 kPa = 1 bar.

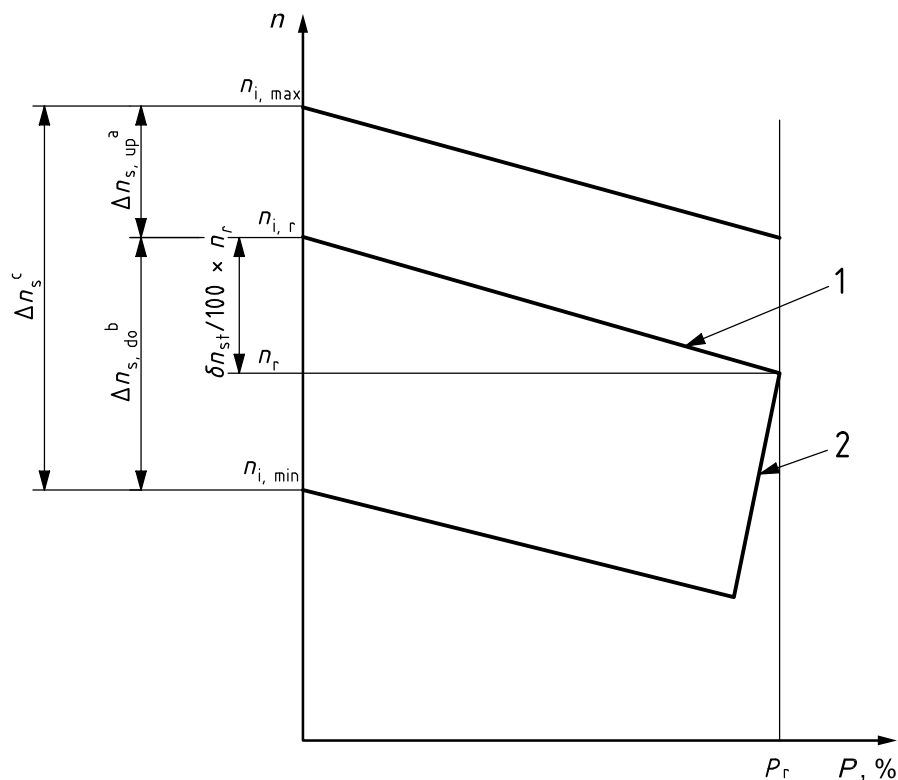

Key

P engine power
 n engine speed

1 speed/power characteristic curve
 2 power limit

a Upward speed setting.
 b Downward speed setting range.
 c Range of speed setting.

Figure 1 — Speed/power characteristic, range of speed setting

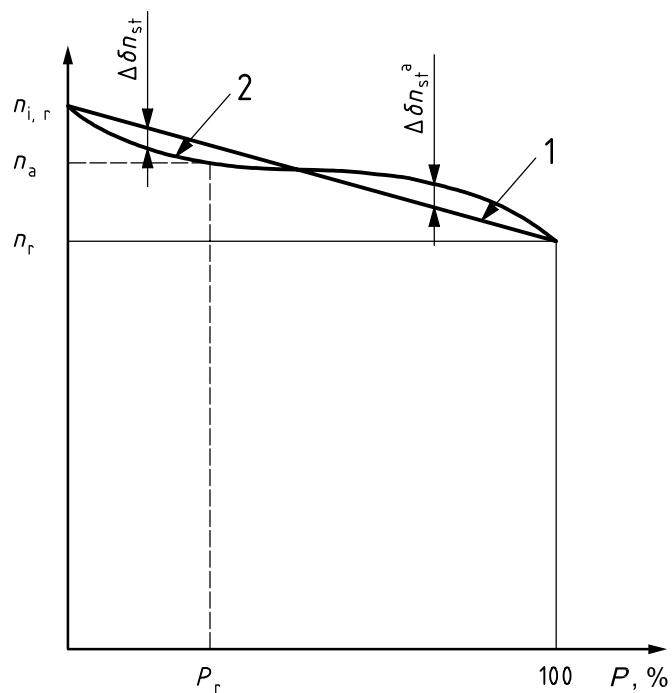

Key

P engine power
 n engine speed

1 linear Speed/Power characteristic curve
 2 speed/Power characteristic curve

^a Speed/Power characteristic deviation.

Figure 2 — Speed/power characteristic deviation from the linear curve

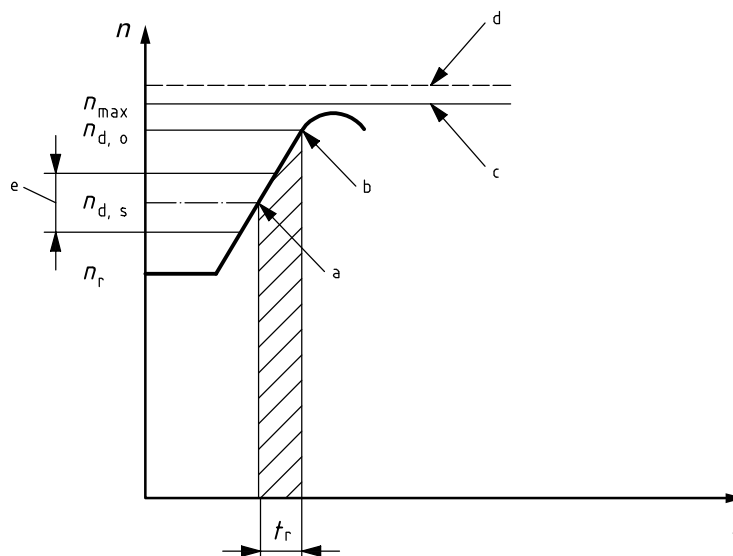

Key

- t time
- n engine speed
- a Setting speed of overspeed limiting device.
- b Operating speed of overspeed limiting device.
- c Maximum permissible speed.
- d Speed limit.
- e Adjustment range.

Figure 3 — Typical speed curve illustrating engine overspeed

4 Other regulations and additional requirements

For RIC engines driving a.c. generating sets used on board ships and offshore installations which have to comply with rules of a classification society, the additional requirements of the classification society shall be observed. The classification society name shall be stated by the customer prior to placing the order.

For engines operating in non-classified equipment, any additional requirements are subject to agreement between the manufacturer and customer.

If special requirements arising from regulations or a regulatory authority (e.g. inspecting and/or legislative authorities) have to be met, the authority name shall be stated by the customer prior to placing the order.

Any additional requirements shall be subject to agreement between the manufacturer and customer.

5 General characteristics

5.1 Power characteristics

5.1.1 General

The power output required at the RIC engine coupling (net brake power as defined in ISO 3046-1) shall take into account:

- a) the electrical power required for the customer's plant;
- b) the electrical power required for the essential independent auxiliaries (see ISO 3046-1); and
- c) the power loss in the a.c. generator itself.

In addition to the steady-state power requirement, sudden power changes due to additional loads (e.g. caused by electric motor starting) shall be taken into account since they affect the power output characteristics of the RIC engine and voltage characteristics of the a.c. generator.

The generating set manufacturer shall take account of the connected electrical load characteristics and of any load acceptance conditions expected by the customer.

5.1.2 ISO standard power

The power of the RIC engine shall be declared by the engine manufacturer in accordance with the requirements of ISO 3046-1.

5.1.3 Service power

The RIC engine power (see ISO 8528-1) required for a particular application to drive the a.c. generator under site conditions with any essential independent auxiliaries attached/connected (see ISO 3046-1) and with the generating set developing its rated electrical power, shall be determined in accordance with the requirements of ISO 3046-1.

In order to ensure that a continuous supply of electrical power is available to the connected load, it is essential that the actual power output required from the RIC engine driving the a.c. generator is not more than the service power.

5.2 Main characteristics of the RIC engine

The main characteristics of the RIC engine to be used by the generating set manufacturer shall be given by the engine manufacturer and shall include at least:

- a) the power under ISO standard and service conditions;
- b) the declared speed; and
- c) the consumption of fuel and lubricating oil under ISO standard conditions.

This information enables the generating set manufacturer and customer to confirm that the main characteristics of the RIC engines available are suitable for the intended application.

In order to evaluate the generating set in service conditions (in particular, sudden-load acceptance), it is necessary to establish the Brake Mean Effective Pressure, p_{me} (kPa), of the engine used, corresponding to the engine power when the generating set is operating at its declared power and rated frequency and is defined as follows:

$$p_{me} = \frac{KP}{V_{st} \times n_r}$$

where $K = 1,2 \times 10^5$ for a four-stroke engine and $K = 0,6 \times 10^5$ for a two-stroke engine.

5.3 Low-load operation

The customer shall be made aware that extended running under low load may affect the reliability and life of the RIC engine. The RIC engine manufacturer shall provide the generating set manufacturer with data regarding the minimum load the RIC engine is capable of sustaining indefinitely without deterioration. If the generating set is to be operated at lower loads than this minimum, the RIC engine manufacturer shall specify the measures to be adopted and/or corrective procedures to be used to alleviate the problem.

6 Speed characteristics

6.1 General

The choice of governing system fitted to the RIC engine shall be based upon the steady-state and transient speed performance requested by the customer. The generating set manufacturer shall ensure that a suitable governing system, approved by the RIC engine manufacturer, is selected to meet the application requirements.

ISO 3046-4 establishes general requirements and parameters of speed governing systems and general requirements for overspeed protection devices.

The terms, symbols and definitions for speed characteristics are given in Clause 3.

6.2 Types of speed governor used for generating sets

6.2.1 Proportional (P) governor

A speed governor which corrects the control signal in proportion to a load related speed change. The change in electrical load results in a change of the steady-state speed of the RIC engine.

6.2.2 Proportional Integral (PI) governor

A P governor which in addition proportionally corrects the control signal to the RIC engine when there is a load-related change in speed due to a change in the a.c. generator electrical load. It also corrects the change in speed with an integral action. If this governor type is used, a change in electrical load does not usually result in a change in speed. To make generating set parallel operation possible, and if no additional governing of the load sharing is provided, a PI governor shall also work as a P governor.

6.2.3 Proportional Integral Differential (PID) governor

A PI governor which in addition corrects the control signal as a function of the rate of speed change (differential action). If this governor type is used, a change in electrical load does not usually result in a change in speed. To make parallel generating set operation possible, and if no additional governing of the load sharing is provided, a PID governor shall also work as a P governor.

6.3 Use of speed governor

6.3.1 General

See 6.3 of ISO 8528-1.

6.3.2 Single operation

Depending on the governing performance required by the application, P, PI and PID governors may be used.

6.3.3 Parallel operation

6.3.3.1 Proportional (P) governor

A proportional governor shall be used for performance Classes G1 and G2 (see Clause 7 of ISO 8528-1:2005).

6.3.3.2 Proportional Integral (PI) governor

A proportional integral governor shall be used for performance Classes G1 to G4. If the governor is used in an isochronous mode, it requires an auxiliary device such as a load-sharing facility.

6.3.3.3 Proportional Integral Differential (PID) governor

A proportional integral differential governor shall be used for performance classes G1 to G4 and in the same way as a PI governor, but with improved transient performance. If the governor is used in an isochronous mode, it requires an auxiliary device such as a load-sharing facility to be installed.

7 RIC engine load acceptance

7.1 General

The load-acceptance behaviour of an RIC engine depends mainly on the type of combustion air supply system installed (see 14.2 of ISO 8528-1).

The generator set manufacturer should consider the actual load-acceptance behaviour of the RIC engine and a.c. generator to be used (see Figures 6 and 7 of ISO 8528-5).

7.2 Non-turbocharged RIC engines

These are RIC engines which are naturally aspirated or pressure-charged by a mechanically driven compressor (supercharged). For these engines, the maximum possible load step is equal to the service power.

7.3 Turbocharged RIC engines

These are RIC engines which are pressure charged by an exhaust gas-driven turbocharger. For these engines, the load steps which may be applied vary according to the brake mean effective pressure (p_{me}), corresponding to the service power.

8 Vibration and noise

8.1 Torsional vibration

The RIC engine produces torsional vibrations in the shaft system of the generating set. Requirements relating to torsional vibrations of RIC engines are dealt with in ISO 3046-5.

The complete generating set has to be considered when calculating torsional vibrations (see ISO 8528-5).

The engine manufacturer shall supply the generating set manufacturer with the necessary information to enable him to ensure satisfactory operation of the engine/generator pair.

8.2 Linear vibration

The RIC engine produces linear vibrations which result in structural vibrations in the baseframe and foundation on which the RIC engine and a.c. generator are mounted. If requested, the engine manufacturer shall provide to the generating set manufacturer data related to the linear vibrations produced.

The complete generating set has to be considered when calculating linear vibrations (see ISO 8528-5).

8.3 Noise

If requested, the RIC engine manufacturer shall provide the generator set manufacturer with noise-related data (see ISO 8528-5).

9 Heat balance

The RIC engine manufacturer shall provide the generating set manufacturer with the on-site condition heat balance data which shall include but not be limited to:

- a) the RIC engine cooling heat, flow rate and temperatures (coolant, oil, air);
- b) the exhaust gas heat, flow rate and temperatures; and
- c) the radiated heat dissipation.

10 Inlet and exhaust system

The RIC engine manufacturer shall provide the generating set manufacturer with data on air aspiration and exhaust gas requirements.

The generating set manufacturer shall take into account the pressure loss limitations specified by the RIC engine manufacturer as follows:

- a) in the pipes, openings or filtering devices of the RIC engine air intake system; and
- b) in the pipes, silencers, etc. for the RIC engine exhaust gases.

11 Starting ability

If the RIC engine is required to start under particular conditions specified by the generating set customer or manufacturer (for instance at low ambient temperature), the RIC engine manufacturer shall provide the generating set manufacturer with starting capability figures under the specified conditions and details of any special starting aids required.

12 Fuel, lubricants and coolants

If necessary, the generating set manufacturer shall provide the RIC engine manufacturer with details of the fuel, lubricating oil and coolant to be used in service.

The RIC engine manufacturer should provide the generating set manufacturer with characteristics of the recommended fuel, lubricants and coolant.

The following fuel characteristics are of particular significance:

- a) density ($\text{kg}\cdot\text{m}^{-3}$);
- b) viscosity ($\text{N}\cdot\text{s}\cdot\text{m}^{-2}$);
- c) calorific value (kJ);
- d) cetane number;
- e) vanadium, sodium, silica and aluminium oxide content (%);
- f) in the case of heavy fuel, the sulphur content (%).

13 Governing system values

The governing system values are shown in Table 2.

Table 2 — Governing system values

Term	Symbol	Unit	Value			
			Performance Class			
			G1	G2	G3	G4
Related downward speed setting range	$\delta n_{s,\text{inf}}$	%	$-(2,5 + \delta n_{s,t})$			AMC ^a
Related upward speed setting range	$\delta n_{s,\text{sup}}$	%	+ 2,5			
Rate of change of speed setting	v_n	$\%s^{-1}$	0,2 to 1			
Speed droop	δn_{st}	%	≤ 8	≤ 5	≤ 3	

^a AMC = By agreement between the manufacturer and customer.

1
2
3
4
5
6
7
8
9
10
11
12
13
14
15
16
17
18
19
20
21
22
23
24
25
26
27
28
29
30
31
32
33
34
35
36
37
38
39
40
41
42
43
44
45
46
47
48
49
50
51
52
53
54
55
56
57
58
59
60
61
62
63
64
65
66
67
68
69
70
71
72
73
74
75
76
77
78
79
80
81
82
83
84
85
86
87
88
89
90
91
92
93
94
95
96
97
98
99
100

ICS 27.020; 29.160.40

Price based on 12 pages