

INTERNATIONAL STANDARD

ISO
8478

First edition
1996-12-01

Photography — Camera lenses — Measurement of ISO spectral transmittance

*Photographie — Objectifs photographiques — Mesurage du facteur
spectral de transmission ISO*

This material is reproduced from ISO documents under International Organization for Standardization (ISO) Copyright License number IHS/ICC/1996. Not for resale. No part of these ISO documents may be reproduced in any form, electronic retrieval system or otherwise, except as allowed in the copyright law of the country of use, or with the prior written consent of ISO (Case postale 56, 1211 Geneva 20, Switzerland, Fax +41 22 734 10 79), IHS or the ISO Licensor's members.



Referencé number
ISO 8478:1996(E)

ISO 8478:1996(E)**Foreword**

ISO (the International Organization for Standardization) is a worldwide federation of national standards bodies (ISO member bodies). The work of preparing International Standards is normally carried out through ISO technical committees. Each member body interested in a subject for which a technical committee has been established has the right to be represented on that committee. International organizations, governmental and non-governmental, in liaison with ISO, also take part in the work. ISO collaborates closely with the International Electrotechnical Commission (IEC) on all matters of electrotechnical standardization.

Draft International Standards adopted by the technical committees are circulated to the member bodies for voting. Publication as an International Standard requires approval by at least 75 % of the member bodies casting a vote.

International Standard ISO 8478 was prepared by Technical Committee ISO/TC 42, *Photography*.

Annex A forms an integral part of this International Standard.

© ISO 1996

All rights reserved. Unless otherwise specified, no part of this publication may be reproduced or utilized in any form or by any means, electronic or mechanical, including photocopying and microfilm, without permission in writing from the publisher.

International Organization for Standardization
Case Postale 56 • CH-1211 Genève 20 • Switzerland

Printed in Switzerland

Introduction

This International Standard describes a preferred method for the measurement of spectral transmittance. Alternative methods may be used provided that the method gives the same result as that obtained according to this International Standard within the tolerances allowed by it. In the case of lenses with very long or short focal lengths, and in large aperture lenses, care should be taken to maintain the ideal integration properties of the integrating sphere.

Spectral transmittance of the lens under test may vary with the diameter of the incident beam and with the angle of incidence of the beam. In order to obtain uniform results, this International Standard specifies that the measurement is to be made with a collimated beam incident upon the lens along its optical axis, and filling the central half diameter of its entrance pupil at its minimum f -number.

In the case of lenses with very long or short focal lengths, the measuring method specified in this International Standard may not be applicable due to the difficulty in preparing a very big or very small integrating sphere. In such a case, an alternative method may be used provided that it gives the same result as that obtained according to this International Standard within the tolerances allowed by this standard.

Annex A which forms an integral part of this International Standard, is provided to give a particular method for measuring the spectral transmittance of mirror lenses.

Photography — Camera lenses — Measurement of ISO spectral transmittance

1 Scope

This International Standard specifies a method for measuring the spectral transmittance of camera lenses. It describes particular conditions for measuring the axial spectral transmittance, over a wavelength range from 350 nm to 700 nm, of camera lenses which are intended to be used mainly for taking pictures of very distant objects.

If the spectral transmittance values are used exclusively for the calculation of the ISO colour contribution index (see ISO 6728), throughout this International Standard, the wavelength range should read 370 nm to 680 nm.

This International Standard is also applicable to mirror lenses (see annex A).

2 Normative reference

The following standard contains provisions which, through reference in this text, constitute provisions of this International Standard. At the time of publication, the edition indicated was valid. All standards are subject to revision, and parties to agreements based on this International Standard are encouraged to investigate the possibility of applying the most recent edition of the standard indicated below. Members of IEC and ISO maintain registers of currently valid International Standards.

ISO 6728:1983, *Photography — Camera lenses — Determination of ISO colour contribution index (ISO/CCI)*.

3 Definitions

For the purposes of this International Standard, the following definitions apply.

3.1 photographic lens: Lens used for recording the image of an object on photosensitive material, such as a camera or enlarging lens.

NOTE — A projection lens is not a photographic lens.

3.2 camera lens: Lens attached to a still camera used for taking pictures of an object.

3.3 spectral transmittance of a lens: Transmittance denoted by $\tau(\lambda)$ and defined by the equation

$$\tau(\lambda) = \frac{\Phi_{\tau,\lambda}}{\Phi_{i,\lambda}}$$

where

- $\Phi_{\tau,\lambda}$ is the transmitted radiant flux of wavelength λ ;
- $\Phi_{i,\lambda}$ is the corresponding incident radiant flux of wavelength λ .

4 Apparatus

4.1 General

The apparatus (see figure 1) shall consist of a light source, a condenser lens, a monochromator (or narrow-bandwidth filters, in limited applications), an aperture stop, a collimator and an integrating sphere together with a photoelectric detector system.

NOTE — Narrow-band filters are subject to errors due to inter-reflections with other components. The use of narrow-band filters should be limited to applications where proper corrections can be applied.

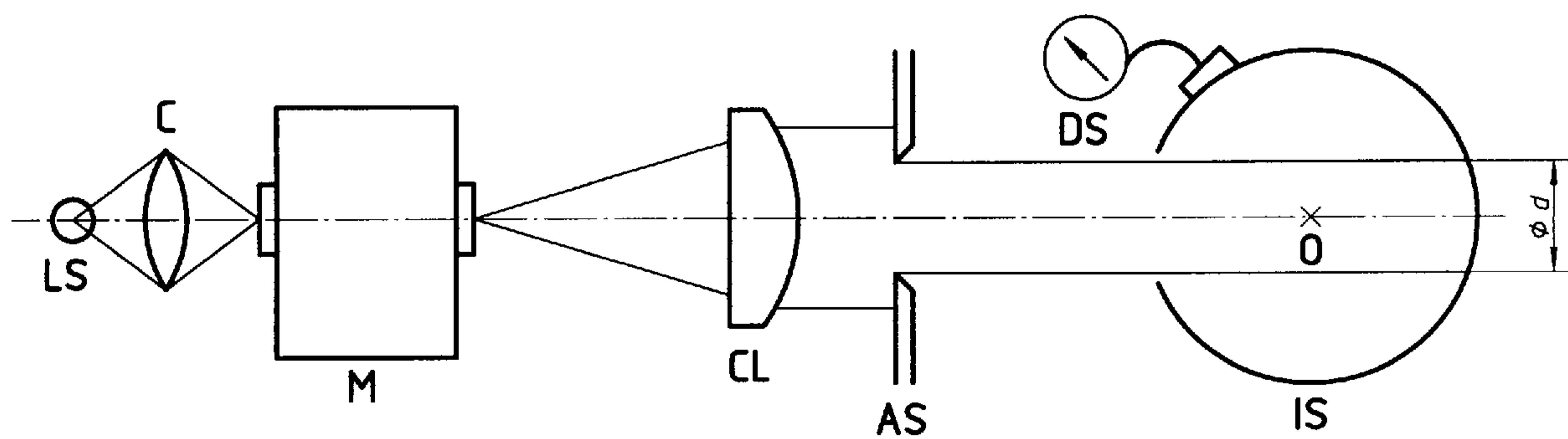

a) Using a collimator lens

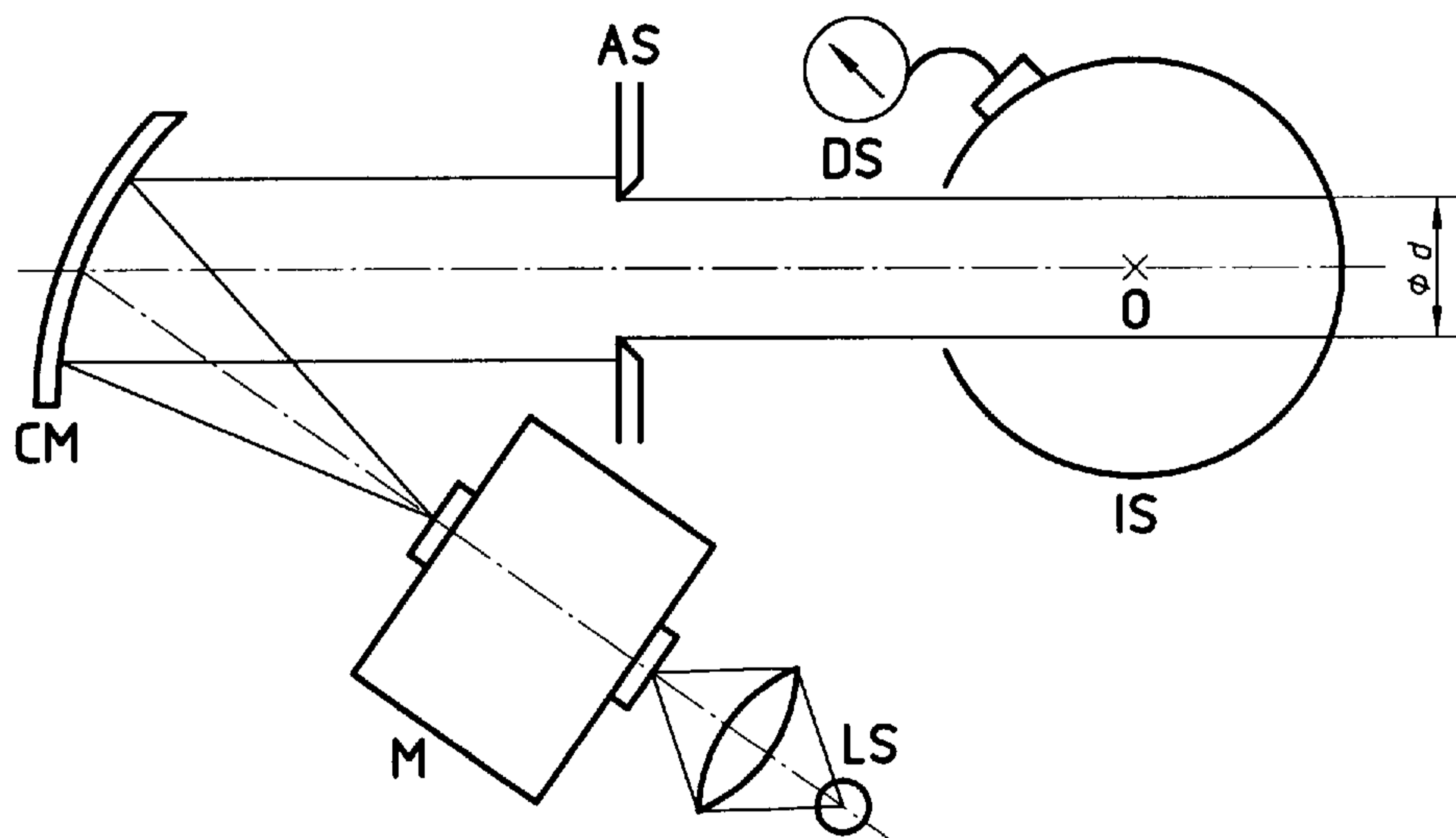

b) Using an off-axis paraboloid mirror collimator

Key

LS	Light source	CM	Collimator mirror	O	Centre of integrating sphere
C	Condenser lens	AS	Aperture stop	d	Diameter of beam
M	Monochromator	IS	Integrating sphere		
CL	Collimator lens	DS	Detector system		

Figure 1 — Arrangement of the apparatus (test lens not shown)

4.2 Light sources

The light source shall be capable of emitting a spatially and temporally stable radiant flux over the wavelength range of 350 nm to 700 nm. Spatial variations shall not exceed the acceptance angle of the condenser; temporal variation shall be less than 1 %.

4.3 Monochromator

The monochromator shall preferably be a double monochromator which shall employ two prisms or two gratings, or one prism and one grating.

If a grating monochromator is used, it shall employ a filter or filters to cut off the higher-order diffracted radiation. The wavelength range shall be from 350 nm to 700 nm.

Narrow-band filters may be used in place of the monochromator, provided that there are sufficient filters to cover the required wavelength interval, and the filters shall have sufficient blocking outside the pass band. Corrections shall be applied for inter-reflections.

For both the monochromator and the narrow-band filters, the wavelength interval and bandwidth shall be 10 nm or less and adjustable. A 20 nm interval and bandwidth is satisfactory in the spectral region where the transmittance variance is less than 0,2 % per nanometre. For the calculation of the ISO colour contribution index, 10 nm intervals are required.

4.4 Collimator

The collimator shall be either a lens or a mirror. In both cases, its focal length shall be at least 30 times the length of the monochromator exit slit.

If a lens is used, its focal length should not change by more than 1 % for any monochromatic radiation within a wavelength range from 350 nm to 700 nm.

If a mirror is used, it shall preferably be of off-axis paraboloid design.

4.5 Aperture stop

The aperture stop shall be circular in shape and its diameter shall be adjustable.

4.6 Integrating sphere

The radius of the integrating sphere shall be selected such that the location and diameter of the beam on the rear wall of the integrating sphere is the same, with or without the lens in position, to within a tolerance of ± 50 %. The diameter of the entrance port shall be greater than half the diameter of the entrance pupil of the lens to be tested.

The spectral reflectance of the diffusing coating on the internal surface of the integrating sphere shall be as high and non-selective as possible over a wavelength range from 350 nm to 700 nm.

4.7 Detector

The detector shall have sufficient responsivity over a wavelength range from 350 nm to 700 nm. The detector's response, in combination with the electronic circuitry, shall be calibrated over the measuring range. The area of the detector shall be as small as possible and the surface of the detector shall be level with the inside surface of the integrating sphere (e.g. the surface of the detector shall be within ± 1 mm of the inside surface of the sphere). The spectral reflectance of the detector surface shall be as close as possible to that of the internal surface of the integrating sphere.

5 Conditions

5.1 The wavelength range shall be from 350 nm to 700 nm.

5.2 The wavelength interval shall be 10 nm or less. If spectral variation is less than 0,2 % per nanometre, the wavelength interval may be 20 nm, but not for the calculation of the ISO colour contribution index.

5.3 The bandwidth shall be less than or equal to the wavelength interval (10 nm, or 20 nm if spectral variation is less than 0,2 % per nanometre).

6 Procedure

For each wavelength within the range (see clause 5), proceed as follows.

6.1 Set the monochromator wavelength control to obtain monochromatic radiation of the required wavelength λ .

6.2 Adjust the diameter of the aperture stop so that the beam diameter equals (50 ± 5) % of the nominal diameter of the entrance pupil of the lens to be tested. See figure 2.

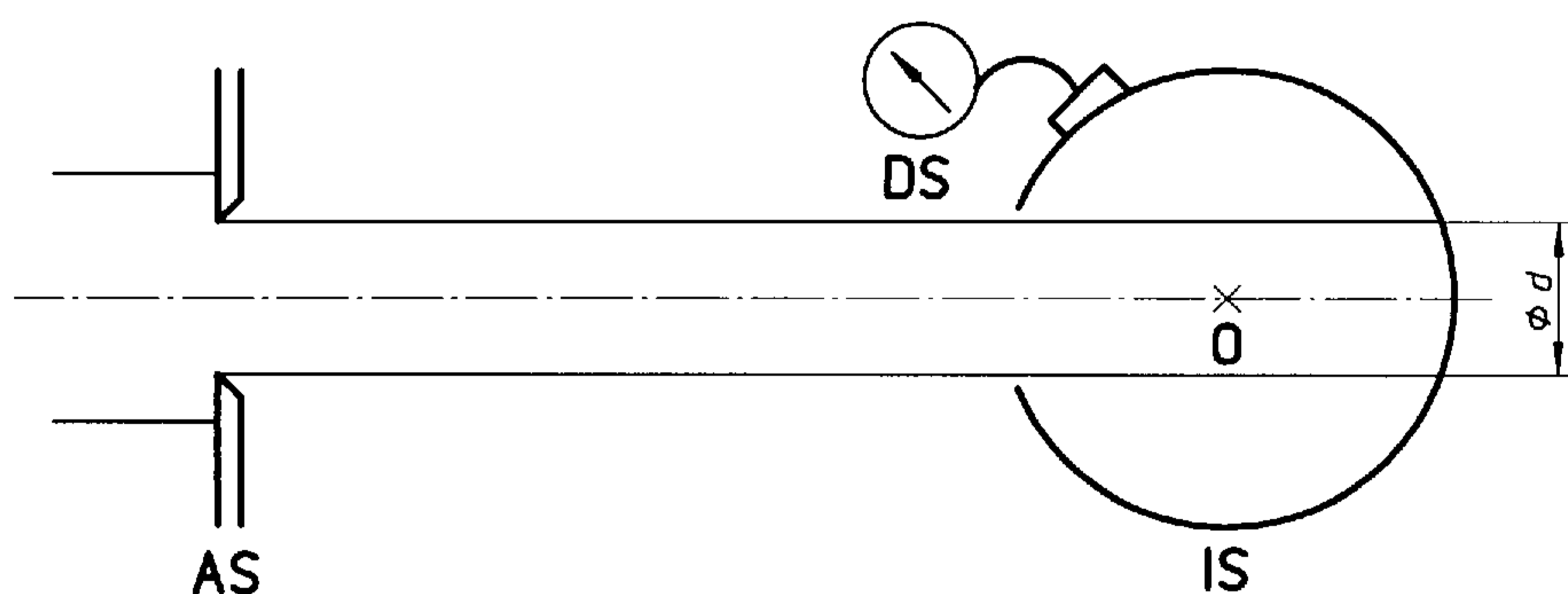

a) Measuring incident radiant flux

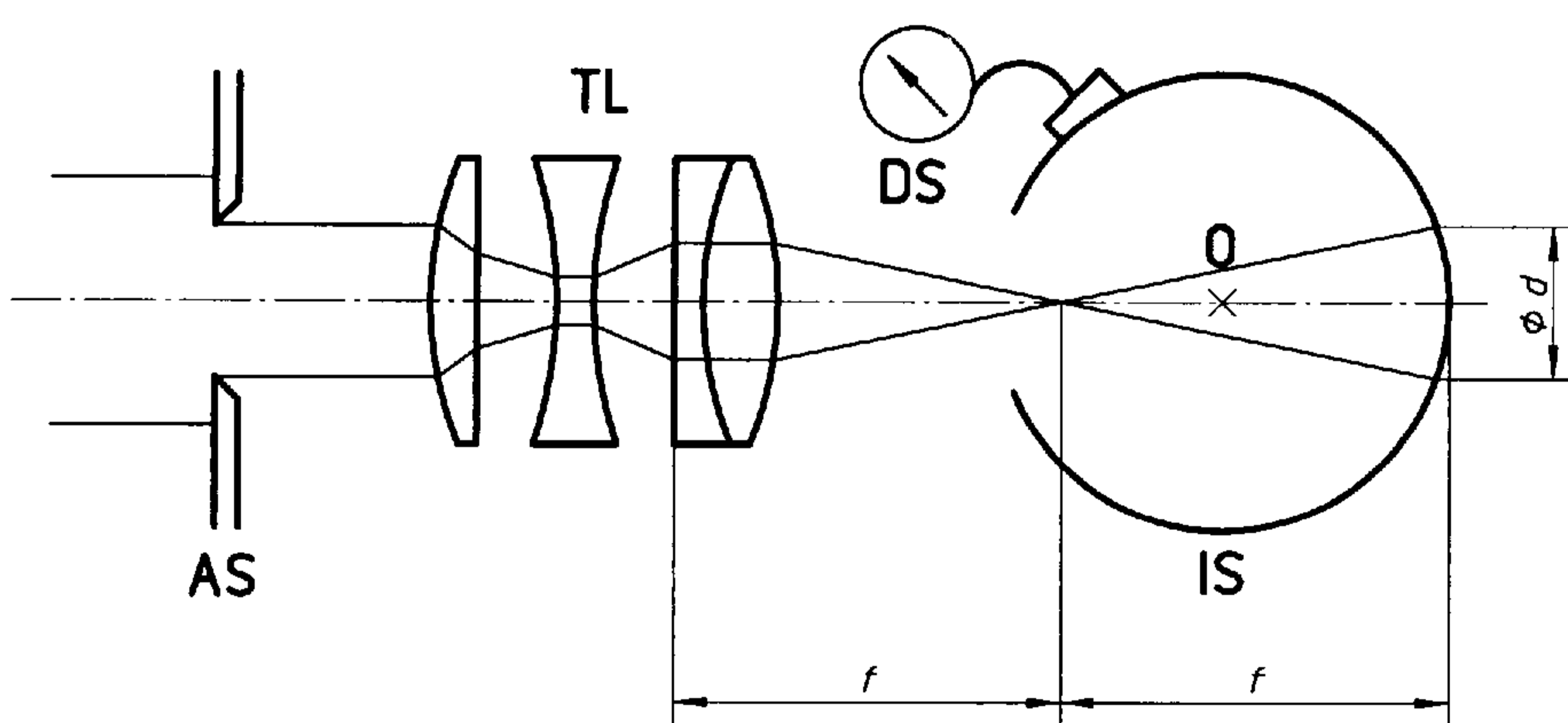

b) Measuring transmitted radiant flux

Key

AS	Aperture stop	DS	Detector system	f	Focal length of the lens under test
IS	Integrating sphere	TL	Lens under test	O	Centre of integrating sphere
d	Diameter of beam on rear wall of integrating sphere				

Figure 2 — Measurement of spectral transmittance (detection end shown only)

6.3 Measure and record the detector output, which is proportional to $\Phi_{i,\lambda}$.

6.4 Insert the lens to be tested in the optical path with the front surface of the lens (side surface of the object) facing the aperture stop. See figure 2.

6.5 The position of the lens shall be such that the beam size requirements, with and without the lens in position, shall be maintained to a tolerance of $\pm 50\%$ as depicted in figures 2a) and 2b). The distance between the aperture stop and the lens, and that between the lens and the entrance port of the integrating sphere, shall be such that inter-reflections between the surface of the lens and the aperture stop, and those between the lens surface and the entrance pupil, shall not introduce any error in the measurement.

6.6 Measure and record the detector output, which is proportional to $\Phi_{\tau,\lambda}$ (with the lens in position).

6.7 Divide the output with the lens in position (step 6.6) by that with the lens removed from the optical path (step 6.3) to obtain the spectral transmittance

$$\tau(\lambda) = \frac{\Phi_{\tau,\lambda}}{\Phi_{i,\lambda}}$$

6.8 Repeat steps 6.1 to 6.7 for each wavelength.

7 Presentation of the results

The transmittance values measured according to the method specified in this International Standard shall be designated as "ISO spectral transmittance" or denoted as

ISO/ $\tau(\lambda)$.

The transmittance values shall be stated to two places of decimals and given in the form of a table and/or graph. The measurement error shall be stated.

The following information concerning the lens shall also be supplied:

- a) brand name;
- b) manufacturer;
- c) serial number;
- d) marked focal length;
- e) focal-length setting (if zoom lens);
- f) marked f -number;
- g) date the measurements were taken;
- h) comment on the cleanliness of the lens and if it was necessary to clean the surfaces before testing.

Annex A

(normative)

Method for measuring spectral transmittance of mirror lenses

A.1 Apparatus

The apparatus shall be the same as that for ordinary camera lenses, with the exception that the integrating sphere shall be movable in a plane perpendicular to the optical axis.

A.2 Procedure of measurement

For each wavelength within the range (see clause 5), proceed as follows.

- a) Set the monochromator wavelength control to obtain monochromatic radiation of the required wavelength λ .
- b) Adjust the diameter of the aperture stop so that the beam diameter equals (50 ± 5) % of the nominal diameter of the entrance pupil of the lens to be tested, as shown in figures A.1 a) and A.1 c).
- c) Measure and record the detector output, which is proportional to $\Phi_{i,\lambda}$.
- d) Insert the lens to be tested in the optical path with the front surface of the lens (side surface of the object) facing the aperture stop. See figures A.1 a) and A.1 b).
- e) The position of the lens shall be such that the location and diameter of the beam incident on the rear wall of the integrating sphere is the same as, or at least ± 50 % of, that without the lens in the optical path as depicted in figures A.1 a) and A.1 b).
- f) Measure and record the detector output, which is proportional to $\Phi_{t,\lambda}$.
- g) Divide the output with the lens in position [step d)] by that with the lens removed [step c)] to obtain the spectral transmittance.

$$\tau(\lambda) = \frac{\Phi_{t,\lambda}}{\Phi_{i,\lambda}}$$

NOTE — Any non-uniformity on the mirror may influence the measurements. Therefore, it is suggested that the measurement be repeated using three locations on the mirror, each separated by 120° . Results should be presented for all orientations.

- h) Repeat steps a) to g) for each wavelength λ .

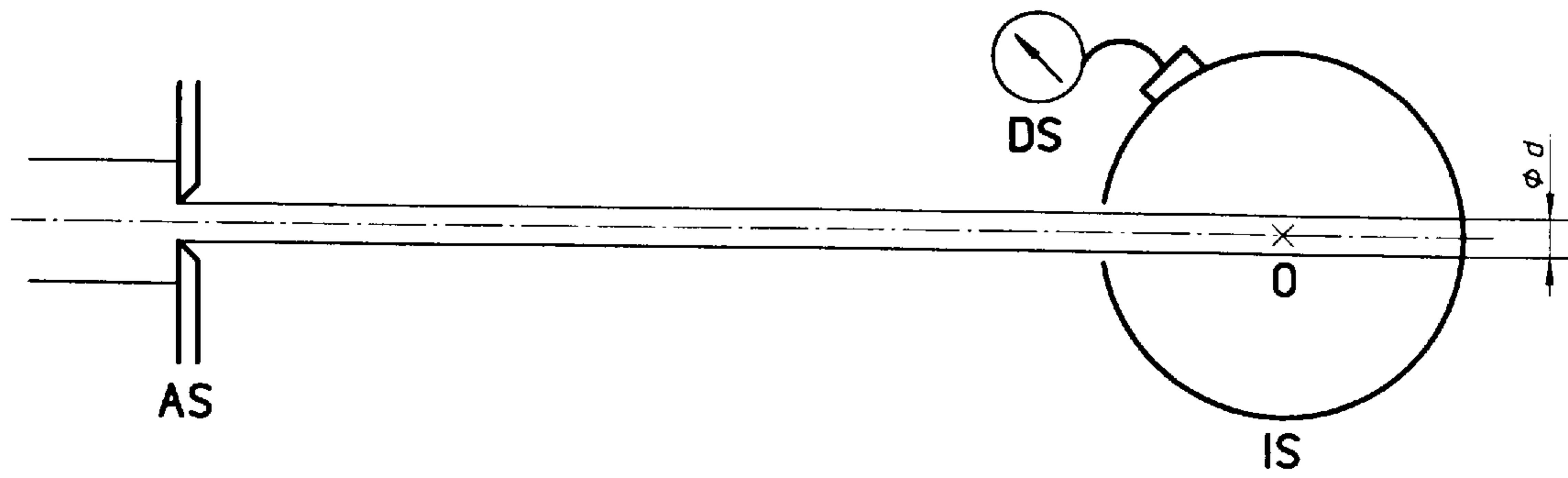

a) Measuring incident radiant flux

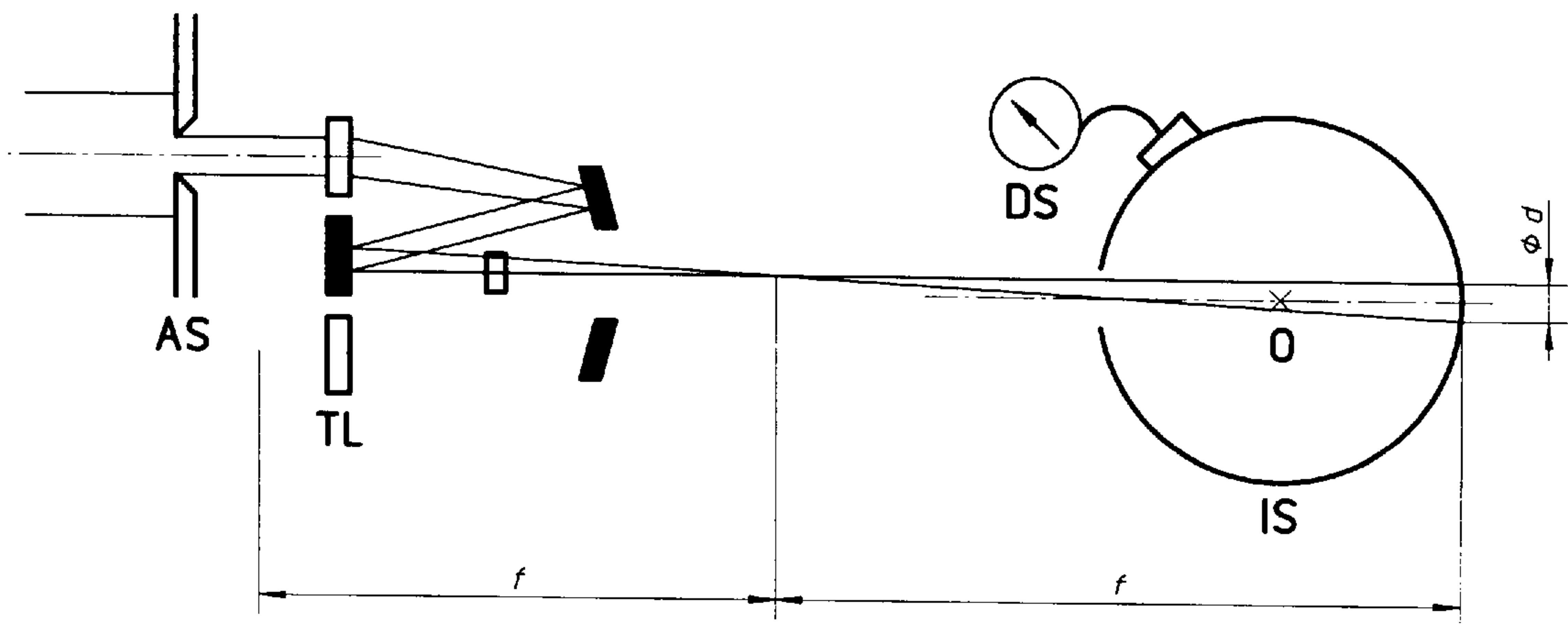

b) Measuring transmitted radiant flux

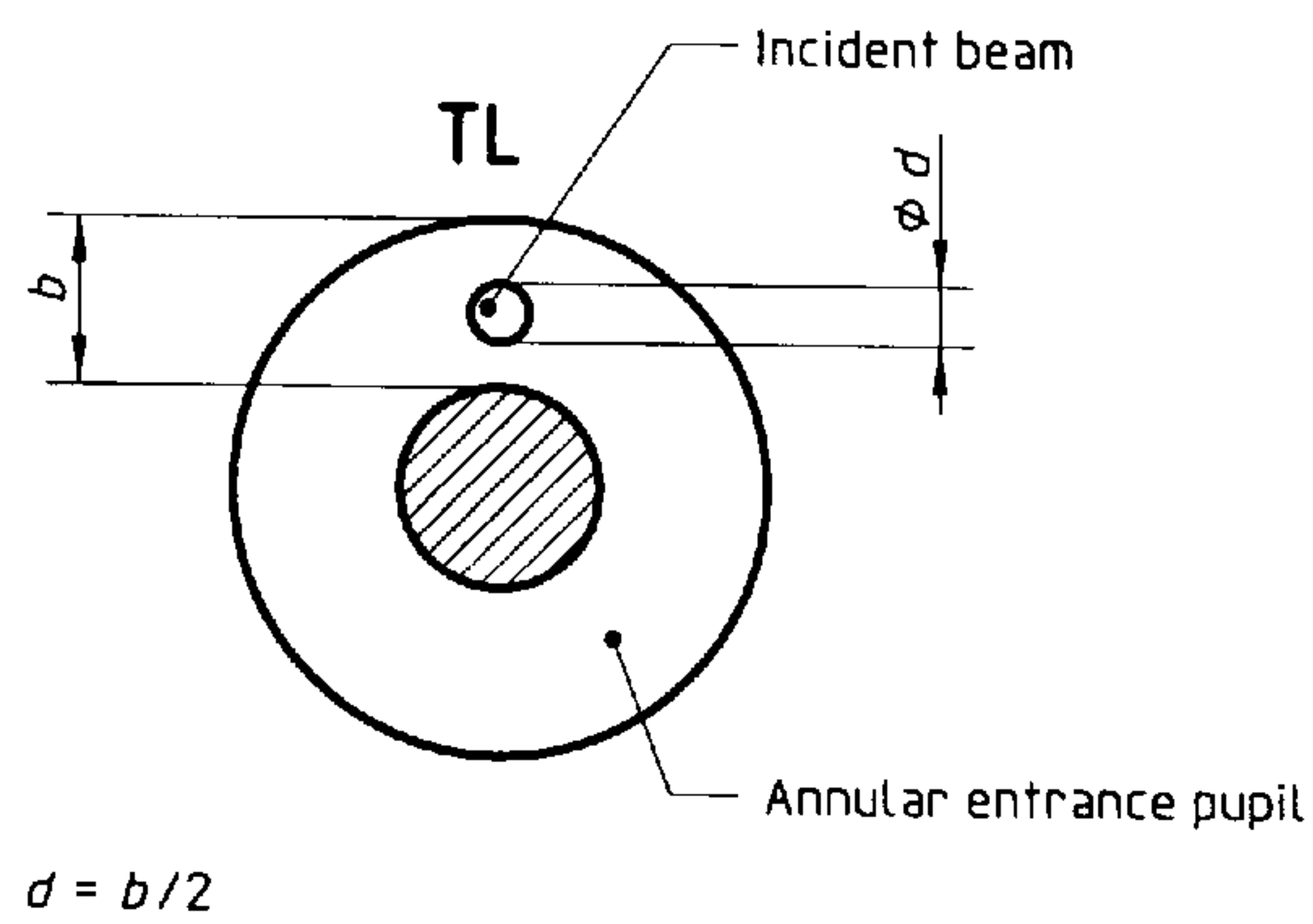

c) Diameter of the incident beam

Key

- | | | |
|-----------------------|--------------------------------|--|
| AS Aperture stop | TL Lens under test | f Focal length of the system under test |
| IS Integrating sphere | O Centre of integrating sphere | b Radial width of the annular entrance pupil |
| DS Detector system | d diameter of beam | |

Figure A.1 — Measurement of the spectral transmittance of mirror lenses

ICS 37.040.10

Descriptors: photography, photographic equipment, cameras, photographic lenses, tests, optical tests, determination, transmittance, optical measurements.

Price based on 7 pages
