

# INTERNATIONAL STANDARD

**ISO**  
**8437**

First edition  
1989-11-15

---

---

## **Snowthrowers — Safety requirements and test procedures**

*Chasse-neige — Exigences de sécurité et essais*



Reference number  
ISO 8437 : 1989 (E)

## Contents

	Page
Foreword .....	iv
 <b>Section 1: General</b>	
1.1 Scope .....	1
1.2 Normative references .....	1
1.3 Definitions .....	1
 <b>Section 2: Walk-behind snowthrower</b>	
2.1 Controls .....	3
2.1.1 General requirements .....	3
2.1.2 Specific requirements .....	3
2.2 Guards, shields, guides, deflectors and housings .....	3
2.2.1 General .....	3
2.2.2 Installation .....	4
2.2.3 Snow guides and deflectors .....	4
2.2.4 Collector and/or impeller housing .....	4
2.2.5 Engine exhaust .....	4
2.2.6 Fuel overflow .....	4
2.3 Servicing .....	4
2.4 Electrical requirements .....	4
2.5 Durable label requirements .....	4
2.6 Tests for power snowthrowers .....	4
2.6.1 Test conditions .....	4
2.6.2 Structural integrity tests .....	5
2.6.3 Controls test .....	5
2.6.4 Temperature of exposed surfaces .....	6
2.6.5 Probe test .....	6
2.6.6 Stability .....	6
2.6.7 Fuel tank overfill test .....	7
2.6.8 Fuel line axial pull test .....	7
2.6.9 Tilt test for controls .....	7

© ISO 1989

All rights reserved. No part of this publication may be reproduced or utilized in any form or by any means, electronic or mechanical, including photocopying and microfilm, without permission in writing from the publisher.

International Organization for Standardization  
Case postale 56 • CH-1211 Genève 20 • Switzerland

Printed in Switzerland

2.7	Safety instructions .....	7
<b>Section 3: Ride-on snowthrower</b>		
3.1	Controls .....	8
3.1.1	General requirements .....	8
3.1.2	Specific requirements .....	8
3.2	Guards, shields, guides, deflectors and housings .....	10
3.2.1	General .....	10
3.2.2	Installation .....	10
3.2.3	Snow guides and deflectors .....	10
3.2.4	Collector and/or impeller housing .....	10
3.2.5	Discharge guide opening .....	10
3.2.6	Hot surfaces .....	10
3.2.7	Engine exhaust .....	11
3.2.8	Fuel overflow .....	11
3.3	Servicing .....	11
3.4	Electrical requirements .....	11
3.5	Durable label requirements .....	11
3.6	General requirements .....	11
3.6.1	Slip-resistant surface .....	11
3.6.2	Reflectors .....	11
3.7	Tests for power snowthrowers .....	11
3.7.1	Test conditions .....	11
3.7.2	Structural integrity tests .....	12
3.7.3	Controls test .....	12
3.7.4	Temperature of exposed surfaces .....	12
3.7.5	Probe test .....	13
3.7.6	Stability requirements and tests .....	13
3.7.7	Braking requirements and tests .....	14
3.7.8	Fuel tank overfill test .....	14
3.7.9	Fuel line axial pull test .....	14
3.7.10	Tilt test for controls .....	15
3.8	Safety instructions .....	15
<b>Figures</b>		
1	Arctic mitten .....	15
2	Operator position, operator control position and hazard zone for walk-behind and ride-on snowthrowers .....	16
3	Snowthrower housing .....	18
4	Impact test fixture .....	19
5	Probe .....	20
<b>Annexes</b>		
A	Safety instructions for walk-behind and ride-on snowthrowers .....	21
B	Bibliography .....	23

## Foreword

ISO (the International Organization for Standardization) is a worldwide federation of national standards bodies (ISO member bodies). The work of preparing International Standards is normally carried out through ISO technical committees. Each member body interested in a subject for which a technical committee has been established has the right to be represented on that committee. International organizations, governmental and non-governmental, in liaison with ISO, also take part in the work. ISO collaborates closely with the International Electrotechnical Commission (IEC) on all matters of electrotechnical standardization.

Draft International Standards adopted by the technical committees are circulated to the member bodies for approval before their acceptance as International Standards by the ISO Council. They are approved in accordance with ISO procedures requiring at least 75 % approval by the member bodies voting.

International Standard ISO 8437 was prepared by Technical Committee ISO/TC 23, *Tractors and machinery for agriculture and forestry*.

Annex A forms an integral part of this International Standard. Annex B is given for information only.

# Snowthrowers — Safety requirements and test procedures

## Section 1: General

### 1.1 Scope

This International Standard specifies safety requirements and test procedures applicable to walk-behind power snowthrowers, riding power snowthrowers, lawn riding tractors or lawn and garden tractors (as defined in ISO 5395-1) used with snowthrower attachments, and to snowthrower attachments themselves.

It does not apply to airport, highway and agricultural types of snow removal machines and equipment.

### 1.2 Normative references

The following standards contain provisions which, through reference in this text, constitute provisions of this International Standard. At the time of publication, the editions indicated were valid. All standards are subject to revision, and parties to agreements based on this International Standard are encouraged to investigate the possibility of applying the most recent editions of the standards indicated below. Members of IEC and ISO maintain registers of currently valid International Standards.

ISO 3304:1985, *Plain and seamless precision steel tubes — Technical conditions for delivery.*

ISO 3305:1985, *Plain and welded precision steel tubes — Technical conditions for delivery.*

ISO 3306:1985, *Plain and as-welded and sized precision steel tubes — Technical conditions for delivery.*

ISO 4200:1985, *Plain and steel tubes, welded and seamless — General tables of dimensions and masses per unit length.*

ISO 5395: —<sup>1)</sup>, *Power lawn mowers, lawn tractors, and lawn and garden tractors, professional mowers, and lawn and garden tractors with attachments — Definitions, safety requirements and test procedures.*

### 1.3 Definitions

For the purposes of this International Standard, the following definitions apply.

**1.3.1 arctic mitten:** Large insulated mitten meeting the dimensions in figure 1.

**1.3.2 barrier:** Vertical plane determined by an obstruction, such as a handle or steering-wheel, that restrains the operator. (See figure 2.)

**1.3.3 collector:** Auger or similar device used to gather snow.

**1.3.4 collector housing:** Structure, framework, or integral shields that limit access to and egress of material from the collector.

**1.3.5 durable label:** Label that is considered to be virtually permanent.

**1.3.6 hazard zone:** Three-dimensional area that might be hazardous for a person to occupy. (See figure 2.)

**1.3.7 impeller:** Power-driven device that imparts energy to discharge the snow. For the purposes of this International Standard, when the collecting function is combined with the impelling function, the device is called an impeller.

**1.3.8 impeller housing:** Structure, framework, or integral shield that limits access to and egress of material from the impeller.

**1.3.9 legible lettering:** Lettering having a minimum height of one unit for every 500 units of viewing distance, or 3 mm, whichever is greater.

**1.3.10 operator control position:** Area (space) within which all controls requiring operation from the operator position are located. (See figure 2.)

**1.3.11 operator position:** Area occupied by the operator during operation of the machine. (See figure 2.)

1) To be published.

**1.3.12 projected exhaust outlet area:** Projection of the exhaust outlet openings perpendicular to the perimeter of the openings. For multiple openings, such as perforated outlets, the perimeter is determined by connecting the adjacent outermost holes with a series of tangent lines to circumscribe the area of the outlet holes pattern. (A 360° hole pattern on the outer perimeter of the exhaust system will require connecting lines at each end of the hole pattern.) For tubular or ducted outlet(s), the projection is determined by an extension from the walls of each outlet.

**1.3.13 snow discharge deflector:** Movable component used to direct snow discharging from a snow discharge guide.

**1.3.14 snow discharge guide:** Movable or fixed component that directs snow discharging from the impeller housing.

**1.3.15 ride-on snowthrower:** Self-propelled ride-on machine that is designed for throwing snow.

**1.3.16 self-propelled snowthrower:** Snowthrower equipped with a means for powered propulsion, other than the collector or impeller, such as wheels or tracks.

**1.3.17 walk-behind snowthrower:** Snowthrowing machine, either pushed or self-propelled, normally controlled by the operator walking behind the unit.

## Section 2: Walk-behind snowthrower

### 2.1 Controls

#### 2.1.1 General requirements

##### 2.1.1.1 Control identification

Durable labels shall be used to identify and show the direction of operation of all operating controls except the snow discharge guides, for which identification is optional. Labels shall be located near or on the control.

##### 2.1.1.2 Control location

**2.1.1.2.1** Engine controls shall not be located in the hazard zone [see figure 2 a)].

**2.1.1.2.2** All other operating controls shall be located in the operator control position [see figure 2 a)] convenient to the 5th to 95th percentile adult male dressed appropriately for the climate conditions.

##### 2.1.1.3 Operability

All operating controls shall be operable by an operator wearing arctic mittens (see figure 1).

##### 2.1.1.4 Control design

Controls shall be designed to prevent hazardous conditions, such as pinching or cutting the operator, during normal operation of the control with or without arctic mittens.

##### 2.1.1.5 Resistance to movement

Controls shall have sufficient resistance to movement to meet the requirements of 2.6.2.1 and 2.6.3. Tilt of the machine shall not affect movement of controls as determined by 2.6.9.

#### 2.1.2 Specific requirements

##### 2.1.2.1 Shutoff control device

A shutoff control device shall be provided to stop operations of the engine. This device shall require manual and intentional activation in order to start the engine. A key switch, or similar device, shall be provided to prevent unauthorized starting of the engine, unless manual starting is the only means of starting. The shutoff control device and the key switch or similar device may be combined in one control.

##### 2.1.2.2 Engine speed control

The direction of motion for an engine speed hand-lever control shall be generally forward or upward, or both, to increase speed, and generally rearward or downward, or both, to decrease speed.

##### 2.1.2.3 Drive interlock

A means shall be provided to prevent the starting of the engine when either the traction drive or impeller drive is engaged. Such means shall not be required on a traction drive or impeller drive that is equipped with operator-presence (normally off) controls. If the engine can only be started from behind the barrier [see figure 2 a)], the impeller drive need not be disengaged.

##### 2.1.2.4 Impeller control

**2.1.2.4.1** A means shall be provided that will automatically stop the impeller in 5 s when the operator leaves the operator position. It shall require intentional reactivation after stopping, and shall comply with the torque requirements of 2.1.2.4.2.

**2.1.2.4.2** The impeller shall stop in 5 s, and remain stopped, when the drive is disengaged. With the engine stopped, the impeller shall resist a torque of at least 1,13 N·m at completion of tests given in 2.6.2.1 and 2.6.3, measured at the impeller shaft in the direction of normal rotation. If an engine kill control is the only control used, the impeller shall stop in 5 s, and the torque requirement shall not apply.

##### 2.1.2.5 Self-propelled walk-behind snowthrowers

**2.1.2.5.1** A traction drive engagement control shall be provided. If the control is not a squeeze-grip control, it shall move in the direction of intended travel for engagement. A means shall be provided to permit the machine to be transported under its own power without impeller engagement.

**2.1.2.5.2** The reverse-traction-engagement control shall be an operator-presence (normally off) control.

**2.1.2.5.3** A means shall be provided to permit engagement of the impeller without engagement of traction drive.

### 2.2 Guards, shields, guides, deflectors and housings

#### 2.2.1 General

All guards, shields, guides, deflectors, and housings shall comply with all applicable test requirements of 2.6.

## 2.2.2 Installation

All guards, shields, guides and deflectors shall be designed to prevent removal from the machine without tools.

## 2.2.3 Snow guides and deflectors

**2.2.3.1** A snow discharge guide(s) shall be provided to control the direction of discharge. The control for adjustment of the guide(s), if provided, shall be located in the operator control position (see figure 2).

NOTE — Snow discharge guides are under study.

**2.2.3.2** A snow discharge deflector(s) shall be provided to direct the flow of discharge leaving the discharge guide(s). The deflector may be part of the discharge guide.

**2.2.3.3** The discharge limit shall not intersect the operator position, as illustrated in figure 2.

**2.2.3.4** A durable label (safety sign) containing the signal work "DANGER" shall be located near the snow discharge opening. It should be accompanied by a message such as "Shut off engine before unclogging discharge chute." (See 2.5 and 2.7.)

## 2.2.4 Collector and/or impeller housing

The sides shall cover the diametral extremities of the housing as shown in figure 3. The housing opening limits shall not intersect the operator position (see figures 2 and 3).

A durable label shall be located on the housing containing the signal word "DANGER". It should be accompanied by a message such as "Avoid injury from rotating auger — keep hands, feet and clothing away." (See 2.5 and 2.7.)

NOTE — Excluded from this requirement are single-stage units that are hand-held and have flexible rubber-type paddles which throw the snow and contact the ground to assist in self-propelling.

## 2.2.5 Engine exhaust

Engine exhaust emissions shall not be directed towards the operator.

## 2.2.6 Fuel overflow

Fuel overflow shall not pass through the projected exhaust outlet area, contact high-tension ignition cables or any non-insulated electrical component, or collect on the machine. Compliance with these requirements shall be determined by the fuel tank overflow test given in 2.6.7.

## 2.3 Servicing

**2.3.1** Specific written instructions with appropriate safety warnings shall be provided with the equipment for those

servicing operations recommended by the manufacturer that must be performed with the engine running.

**2.3.2** General service written instructions shall be provided with the equipment for servicing operations recommended by the manufacturer to maintain the equipment in safe operating condition.

## 2.4 Electrical requirements

Electrical requirements shall comply with the requirements of ISO 5395-2:1981, clause 3.5.

## 2.5 Durable label requirements

Required labels shall comply with ISO 5395-2:1981, clause 3.3.

## 2.6 Tests for power snowthrowers

### 2.6.1 Test conditions

Unless otherwise stated, the test conditions given in 2.6.1.1 to 2.6.1.6 shall apply to 2.6.2.1, 2.6.2.2, 2.6.3, 2.6.4 and 2.6.6.

#### 2.6.1.1 Assembly

The snowthrower shall be completely assembled.

#### 2.6.1.2 Test position

The assembly of 2.6.1.1 shall rest on a horizontal surface.

#### 2.6.1.3 Test speed

The engine shall be set at the equipment manufacturer's maximum specified speed. Then all mechanisms necessary for the equipment to perform its intended functions shall be engaged, where applicable. The control shall be fixed to maintain the maximum speed.

#### 2.6.1.4 Restraints

Resilient restraints may be used to keep the snowthrower in position during the tests given in 2.6.2 and 2.6.3.

#### 2.6.1.5 Number of units to be tested and sequence of tests

For the tests given in this International Standard, the following conditions shall apply.

- The manufacturer has the option of running one or any number of machines for tests (1) to (6).
- For tests (7) and (8), only one machine shall be used.
- Test (7) shall be followed by test (8).



Tests are as follows:

- (1) Temperatures of exposed surfaces (see 2.6.4).
- (2) Probe (see 2.6.5).
- (3) Fuel tank overfill (see 2.6.7).
- (4) Fuel line (see 2.6.8).
- (5) Stability (see 2.6.6).
- (6) Tilt for controls (see 2.6.9).
- (7) Controls (see 2.6.3).
- (8) Structural integrity (see 2.6.2).

## 2.6.2 Structural integrity tests

### 2.6.2.1 Imbalance test

#### 2.6.2.1.1 Test procedure

The impeller imbalance in gram metres shall be determined by the formula:

$$700 D^3$$

where  $D$  is the outside diameter of the impeller, in metres.

The calculated imbalance shall be created by removing or adding material until the required imbalance is obtained. The snowthrower shall be run in this imbalanced condition for 1 h.

#### 2.6.2.1.2 Test acceptance

The machine shall have failed this test if either of the following occurs:

- Loss or failure of any part or component that results in non-compliance with applicable parts of this International Standard.
- Movement of the controls from the position selected at the beginning of test or shifting of the snow discharge guide more than 15° from the selected position.

### 2.6.2.2 Impact test

#### 2.6.2.2.1 Test equipment and conditions

An impact test fixture such as one shown in figure 4 shall be used.

The snowthrower shall be positioned over the fixture as illustrated in figure 4.

The impact rod shall be injected into the impeller as indicated in figure 4.

#### 2.6.2.2.2 Test acceptance

The machine shall have failed this test if either of the following occurs:

- Breaking off of any part of the impeller. (Shearing of devices provided to protect these parts shall not constitute test failure.)
- Fracture or distortion of the impeller housing which will allow the probe (see figure 5) to contact a hazardous component or surface. (Failure in the areas of the 51 mm diameter test hole shall not constitute failure of this test.)

### 2.6.2.3 Guards

#### 2.6.2.3.1 Test procedure

A smooth steel sphere having a diameter of 51 mm and weighing 0,54 kg shall be used.

If guards can be struck from above, the sphere shall be dropped vertically; if not, the sphere shall be suspended by a cord and allowed to fall from rest as a pendulum to strike the guards. In either case, the vertical travel of the sphere shall be 1,3 m.

One drop shall be made on each guard being tested.

For guards made of nonmetallic material the test shall be repeated on both a) and b):

- a) A different sample(s) that has been in an air-oven for 7 h at a uniform temperature not less than 10 °C higher than the maximum operating temperature of the material measured under normal operating conditions, but not less than 70 °C. The sample(s) shall not be tested until it has returned to room temperature.
- b) A sample(s) that has been conditioned at -20 °C for 7 h.

#### 2.6.2.3.2 Test acceptance

The guard shall have failed this test if either of the following occurs:

- Cracking that affects the functional strength of the part.
- Any conditions that result in non-compliance with applicable parts of this International Standard.

Acceptance shall not be affected if a guard deformed during the test can be readily restored to its original shape.

### 2.6.3 Controls test

#### 2.6.3.1 Test procedure

The engine shall be run for 15 min without interruption, with the controls in the disengaged position. This test is not required on a machine with an engine kill switch. This test is to verify that the controls stay in the disengaged position during the 15 min test.

### 2.6.3.2 Test acceptance

The criteria for failure shall be the same as in 2.6.2.1.2. In addition, the machine shall have failed this test if the impeller rotates more than 3 revolutions in the 15 min test period.

## 2.6.4 Temperature of exposed surfaces

### 2.6.4.1 Limitations

All hot surfaces which exceed 66 °C and which might be contacted by the operator during normal starting, operating, or refuelling shall be indicated by a durable safety label (see 2.5 and 2.7) located adjacent to the surface, and be thermally insulated or shielded (if necessary) so that such surfaces will not exceed a temperature of 149 °C at 4,4 °C ambient. Surfaces that must comply are to be determined by the probe test given in 2.6.5.

### 2.6.4.2 Test method

Surface temperatures shall be taken after the engine has operated under no-load for 1 h or until a steady-state temperature has been obtained. The temperature-measuring system shall enable the surface temperature to be determined within 2 %. Temperature measurements shall be made at any temperature and corrected to 4,4 °C ambient.

The corrected surface temperature, in degrees Celsius, is equal to the measured surface temperature, in degrees Celsius + 4,4 °C (ambient temperature, in degrees Celsius).

## 2.6.5 Probe test

### 2.6.5.1 Test procedure

CAUTION: The test is used to check moving parts and the following procedures should be conducted with the engine not running.

Simulate the operator during normal starting and operation of the machine and insert the probe shown in figure 5 into all openings to its maximum depth of 105 mm or until a force of 4,4 N is attained. As the probe is inserted, rotate and position it in all possible angles with the opening, attempting to contact the part or parts under test. The probe shall not be inserted beyond its length of 105 mm.

### 2.6.5.2 Test acceptance

The machine shall be considered properly guarded if one of the following applies:

- a) The hazard cannot be contacted with the probe shown in figure 5 manoeuvred in any manner.
- b) The hazard is under and within the perimeter of the chassis elements, such as the frame or fender, and the

hazard cannot be reached with the probe shown in figure 5 manoeuvred as follows:

- 1) from above the chassis elements, downward through openings in or between the elements;
- 2) underneath the chassis elements allowing only horizontal or downward probe movement, or both: upward probe movement shall not be permitted.

c) The hazard is controlled by an operator-presence control such that when functioning in accordance with a) and b), the probe cannot reach the hazard while simultaneously actuating the operator-presence control in its normal manner.

## 2.6.6 Stability

### 2.6.6.1 General requirements

Compliance with the provisions of 2.6.6 shall not be required on machines weighing less than 45 kg. Stability determination shall be under static conditions with the test requirements given in 2.6.6.1.1 to 2.6.6.1.3.

**2.6.6.1.1** Pneumatic tyres shall be inflated to the pressure recommended in the operator's manual for normal operation.

**2.6.6.1.2** All wheels may be locked to prevent rotation about the axle.

**2.6.6.1.3** The stability requirements shall apply for all tyre combinations on all wheel tread settings approved by the machine manufacturer.

### 2.6.6.2 Test procedure

The stability of the snowthrower shall be determined as follows.

Place the machine on a variable-slope single plate (tilt table) with a friction surface under the wheels equivalent to a 16- to 36-grit abrasive material. The table shall be tilted until

- a) lift-off of the upper wheel or wheels occurs; or
- b) the minimum angle for acceptance as specified in 2.6.6.3 is attained.

Position the machine on the tilt table with its longitudinal centreline parallel to the intersection line of the lowest edge of the table and a horizontal plane. Position the machine first with its right side on the downhill side and then with its left side on the downhill side.

### 2.6.6.3 Test acceptance

**2.6.6.3.1** Lift-off is considered to have occurred when a strip of 20 gauge steel, 51 mm wide, can be pulled from or moved under any tyre with a force of 9 N or less.

**2.6.6.3.2** Lateral test acceptance is determined when the angle of the tilt table with the machine positioned as in 2.6.6.2 can reach a 10° (17,7 %) slope, with either side downhill, before lift-off occurs.

## **2.6.7 Fuel tank overfill test**

### **2.6.7.1 Test procedure**

With the machine on a level plane, the fuel tank inlet shall be overfilled by 100 ml of liquid within 5 s.

### **2.6.7.2 Test liquid**

The test liquid shall be nonflammable and approximately the same viscosity as the fuel intended for use. (Trichlorethane or the equivalent can be used.)

### **2.6.7.3 Test acceptance**

The machine shall have failed this test if any of the following occurs:

- The test liquid passes through the projected exhaust outlet area.
- The test liquid collects on the machine.
- The test liquid comes into contact with high-tension ignition cables or any non-insulated electrical component.

## **2.6.8 Fuel line axial pull test**

Fuel lines shall not pull off fittings or fail when subjected to a 44 N axial pull test. The test is to be performed with the test

liquid in the line. This test is not required of short fuel lines held in position by compression.

## **2.6.9 Tilt test for controls**

The control position shall not be affected by tilting of the machine, snowthrower, or combination of machine and snowthrower.

### **2.6.9.1 Test procedure**

This test shall be conducted in accordance with the stability test procedure in 2.6.5.2.

### **2.6.9.2 Inactivation of controls**

Controls shall be placed in the stop, disengaged, or lift position (or other inactive position).

### **2.6.9.3 Test acceptance**

Controls shall not move to the run, engaged, lowered, or other activating position at the extreme tilt specified for stability acceptance in 2.6.6.3.

## **2.7 Safety instructions**

A durable label shall be provided to inform the user of the potential hazards that may be encountered in the normal operation and servicing of the snowthrower and power-driven attachments.

Similar instructions shall also be included in the operator's manual, supplied by the manufacturer as pertinent instructions for safe operation, such as shown in annex A.

## Section 3: Ride-on snowthrower

### 3.1 Controls

#### 3.1.1 General requirements

##### 3.1.1.1 Control identification

Durable labels shall be used to identify and show the direction of operation of all operating controls except the steering-wheel, manual lift control, and the snow discharge guides, for which identification is optional. Labels shall be located near control positions and shall be legible to the operator when in position to use the control.

##### 3.1.1.2 Control location

**3.1.1.2.1** Engine controls and manual lift controls shall not be in the hazard zone [see figure 2 b)].

**3.1.1.2.2** All other operating controls shall be in the operator control position [see figure 2 b) and 2 c)].

##### 3.1.1.3 Operability

All operating controls shall be operable by an operator wearing arctic mittens (see figure 1).

##### 3.1.1.4 Control design

Controls shall be designed to prevent hazardous conditions, such as pinching or cutting the operator, during normal operation of the control with or without arctic mittens.

##### 3.1.1.5 Resistance to movement

Controls shall have sufficient resistance to movement to meet the requirements of 3.7.2.1 and 3.7.3. Tilt of the machine shall not affect movement of controls as determined by 3.7.10.

#### 3.1.2 Specific requirements

##### 3.1.2.1 Shut-off control device

A shut-off control device shall be provided to stop operation of the engine. This device shall require manual and intentional activation in order to start the engine. A key switch, or similar device, shall be provided to prevent unauthorized starting of the engine, unless manual start is the only means of starting the engine. The shut-off control device and the key switch or similar device may be combined in one control.

##### 3.1.2.2 Engine speed control

###### 3.1.2.2.1 Hand-operated

The direction of motion for an engine speed hand-lever control shall be generally forward or upward, or both, to increase

speed, and generally rearward or downward, or both, to decrease speed.

###### 3.1.2.2.2 Foot-operated

When a foot-operated engine or motor speed control pedal is provided, it shall be operated by the right foot with the direction of motion generally forward or downward, or both, to increase speed. It shall be located within the operator control position.

##### 3.1.2.3 Drive interlock

A means shall be provided to prevent the starting of the engine when either the traction drive or impeller drive is engaged.

##### 3.1.2.4 Impeller control

###### 3.1.2.4.1 Automatic stop

A means shall be provided that will automatically stop the impeller or kill the engine when the operator leaves the operator position. The impeller may resume operation upon reactivation of the operator-presence control, provided the impeller has not stopped. It shall require reactivation after stopping and shall comply with the torque requirement of 3.1.2.4.2.

###### 3.1.2.4.2 Stopping time

The impeller shall stop in 5 s, and remain stopped, when drive is disengaged. With the engine stopped and the drive disengaged, the impeller shall resist a torque of at least 1,13 N·m at completion of the test given in 3.7.2.1 and 3.7.3, measured at the impeller shaft in the direction of normal rotation.

###### 3.1.2.4.3 Stationary operation

A means may be provided to allow stationary operation of the power take-off (PTO) without an operator in the operator position. Such means shall automatically return to the operational mode of 3.1.2.4.1 when the operator returns to the operator position.

###### 3.1.2.4.4 Impeller or traction disengagement

A means shall be provided to permit the machine to be moved under its own power without the impeller engaged. A means shall also be provided to permit engagement of the impeller without engagement of traction drive.

##### 3.1.2.5 Lift controls

**3.1.2.5.1** When hand lift controls are provided, the direction of motion shall be generally forward or downward to lower the

attachment and generally rearward or upward to raise the attachment.

**3.1.2.5.2** When a foot control is provided, the direction of the motion of the forward part of the control shall be generally forward and downward to lower the attachment and generally rearward and upward to raise the attachment.

**3.1.2.5.3** The lifting action of the power-operated lift device shall be rendered inoperative by removal of a key or by some similar device.

### **3.1.2.6 Pedal slip-resistance**

Foot pedals shall have slip-resistant surfaces or other means of minimizing the possibility of the operator's foot slipping off the pedals.

### **3.1.2.7 Control response**

For combination directional and variable-speed controls or directional controls, or their effect on the motion of the machine, whether actuated by hand, foot, or other means, retard shall be accomplished by at least one of the following:

- a) A change in direction of the control actuation other than the general path described by the control. A distinct actuation at right-angles to this general control motion shall be required.
- b) A distinct change in force level of the control actuation at the point of control entry into the selected direction.
- c) A positive means of retarding machine acceleration, such as linkage or valving, so that the operator does not lose control of the machine when passing through the transition zones from neutral to either the forward or reverse direction.

### **3.1.2.8 Clutch control requirements for traction clutch, neutral return, or both**

#### **3.1.2.8.1 Foot-pedal**

When provided, a foot-pedal control shall be actuated by the operator's left foot, with the direction of motion generally forward or downward, or both, for disengagement. Operator-presence (normally off) controls are not included in this requirement.

#### **3.1.2.8.2 Hand-operated control**

When provided, a hand-operated control shall be moved generally rearward or toward the operator for disengagement. Operator-presence (normally off) controls are not included in this requirement.

#### **3.1.2.8.3 Operator-presence (normally off) control**

A generally forward or downward motion of a foot-actuated operator-presence (normally off) control, when provided, shall

produce clutch engagement. A right-foot operator-presence (normally off) control shall be outboard of the service brake pedal.

#### **3.1.2.8.4 Traction clutch or neutral return, or both, and brake combined**

When a foot-operated (either foot) combination machine clutch or neutral return, or both, and a brake control are used, the direction of actuation shall be generally forward or downward, or both, to cause traction disengagement and brake engagement. Provision shall be made to retain control of the machine during the transition zone of brake disengagement to tractive engagement.

### **3.1.2.9 Service brakes**

**3.1.2.9.1** A foot-actuated brake pedal shall be provided. The direction of motion for this pedal shall be generally forward or downward, or both, for engagement (stopping).

**3.1.2.9.2** Brakes combined with traction clutch neutral return, or both, shall meet the requirements of 3.1.2.8.4.

**3.1.2.9.3** When a separate brake pedal is provided, it shall be positioned to be actuated by the operator's right foot.

**3.1.2.9.4** When independent wheel brakes are provided with a pedal to control each wheel, both pedals shall be actuated by the operator's right foot, with the inner pedal controlling the left wheel and the outer pedal controlling the right wheel. In addition, means shall be provided to lock the pedals together.

**3.1.2.9.5** The service brake shall override hand-operated and operator-presence (normally off) traction drive control.

### **3.1.2.10 Parking brake**

**3.1.2.10.1** A parking brake shall be provided and the control shall be located convenient to the operator. The direction of engagement shall be clearly identified with a durable label.

When hand-operated, the parking brake control shall be moved generally rearward or upward to engage or set. When foot-operated, the parking brake control shall be moved generally downward or forward to engage or set.

**3.1.2.10.2** The parking brake may be in combination with the service brake.

### **3.1.2.11 Traction speed control**

**3.1.2.11.1** Fixed-ratio transmission speed selector control(s), when provided, shall be located within the operator control

position, and the shifting pattern(s) shall be clearly identified with a durable label.

**3.1.2.11.2** A hand-operated direction control for engine drive machines (nonvariable speed), when provided, shall be moved generally forward for forward machine motion, and generally rearward for rearward machine motion. A neutral position shall be provided and provision shall be made to retard movement of the control into the forward or rearward direction.

A hand-operated direction control for electric drive machines (nonvariable speed), when provided, shall be moved generally forward for forward machine motion, and generally rearward for rearward machine motion. Provision shall be made to retard movement of the control or its effect when moving into the forward or rearward direction.

**3.1.2.11.3** A hand-operated variable speed machine control, when provided, shall be moved generally forward or upward, or both, to increase speed.

**3.1.2.11.4** A single-lever hand-operated combination directional and variable speed control, when provided, shall have a definite neutral zone with some means of retarding the control or its effect when moving into the forward or rearward direction. The control shall be moved generally forward for forward travel and increasing forward speed, and shall be moved generally rearward for rearward travel and increasing rearward speed. The control shall remain in the selected position or move to a slower speed position unless repositioned by operator action.

**3.1.2.11.5** The foot-actuated combination directional and variable speed control shall be operated as follows.

If a single pedal is used for combination directional and variable speed control, it shall be operated by the right foot. It shall produce forward motion with a generally forward or downward toe motion on the pedal, and shall produce rearward motion with a generally rearward or downward heel motion. Increased displacement of the pedal shall produce increased speed in either direction. Provisions shall be made for a definite neutral zone with some means of retarding the control or its effect when moving into the generally forward or rearward directions.

If two pedals are used for the combination direction and variable speed control, they shall both be operated by the right foot. Generally forward or downward motion on the outer pedal shall produce reverse motion and increased rearward speed of the machine. Generally forward or downward motion on the inner pedal shall produce forward motion and increased forward speed of the machine.

### **3.1.2.12 Steering control**

**3.1.2.12.1** Clockwise motion of the steering control shall effect a right turn, and a counterclockwise motion shall effect a left turn.

**3.1.2.12.2** The steering mechanism shall not lock in any operating position.

**3.1.2.12.3** Tiller bar steering shall not be permitted.

## **3.2 Guards, shields, guides, deflectors and housings**

### **3.2.1 General**

All guards, shields, guides, deflectors, and housings shall comply with all applicable test requirements of 3.7.

### **3.2.2 Installation**

All guards, shields, guides, and deflectors shall be designed to prevent removal from the machine without tools.

### **3.2.3 Snow guides and deflectors**

**3.2.3.1** Snow discharge guide(s) shall be provided to control the direction of discharge. The control for adjustment of the guide(s) shall be located in the operator control position [see figure 2 b)].

**3.2.3.2** Snow discharge deflector(s) shall be provided to direct the flow of the discharge guide(s). The deflector may be part of the discharge guide.

**3.2.3.3** The discharge limit shall not intersect the operator position, as illustrated in figure 2 b).

**3.2.3.4** A durable label shall be located near the snow discharge opening containing the signal word "DANGER". It should be accompanied by a message such as "Shut off engine before unclogging discharge chute." (See 3.5 and 3.7.)

### **3.2.4 Collector and/or impeller housing**

The sides shall cover the diametral extremities of the housing as shown in figure 3. The housing opening limits shall not intersect the operator position (see figures 2 and 3).

A durable label shall be located on the collector housing containing the signal word "DANGER". It should be accompanied by a message such as "Avoid injury from rotating auger — keep hands, feet and clothing away." (See 3.5 and 3.7.)

### **3.2.5 Discharge guide opening**

(Under study)

### **3.2.6 Hot surfaces**

All exposed surfaces that may be contacted during normal starting, mounting, operating, and refuelling of the machine shall meet the requirements of 3.7.4.

### 3.2.7 Engine exhaust

Engine exhaust emissions shall not be directed at the operator during normal starting, mounting, and operation of the machine.

### 3.2.8 Fuel overflow

Fuel overflow shall not pass through the projected exhaust outlet area, contact high-tension ignition cables, or non-insulated electrical components, or collect on the machine. Compliance shall be determined by the fuel tank overfill test given in 3.7.8.

## 3.3 Servicing

**3.3.1** Specific written instructions with appropriate safety warnings shall be provided with the equipment for those servicing operations recommended by the manufacturer that must be performed with the engine running.

**3.3.2** General service written instructions shall be provided with the equipment for servicing operations recommended by the manufacturer to maintain the equipment in safe operating condition.

## 3.4 Electrical requirements

Electrical requirement shall comply with the requirements of ISO 5395-2:1981, clause 3.5.

## 3.5 Durable label requirements

Required labels shall comply with ISO 5395-2:1981, clause 3.3.

## 3.6 General requirements

### 3.6.1 Slip-resistant surface

A slip-resistant surface or other means shall be provided to minimize the possibility of an operator's foot slipping off the foot support(s) or platform(s).

### 3.6.2 Reflectors

Machines with a snowthrower shall be equipped with two red-colour reflex reflectors. They shall face rearward and be mounted a minimum of 300 mm above the ground. A red tail-light, visible at 90 m may be substituted for reflectors. Reflectors or tail-lights may be provided with the snowthrower attachment if the propelling machine is not equipped with reflectors or tail-lights.

## 3.7 Tests for power snowthrowers

### 3.7.1 Test conditions

Unless otherwise stated, the test conditions given in 3.7.1.1 to 3.7.1.5 shall apply to 3.7.2.1, 3.7.2.2, 3.7.3, 3.7.4, 3.7.6, 3.7.7 and 3.7.8.

#### 3.7.1.1 Assembly

The snowthrower shall be completely assembled. A snowthrower attachment shall be mounted on the machine.

#### 3.7.1.2 Test position

The assembly of 3.7.1.1 shall rest on a horizontal surface.

#### 3.7.1.3 Test speed

The engine shall be set at the equipment manufacturer's maximum specified speed. Then all mechanisms necessary for the equipment to perform its intended functions shall be engaged where applicable. The control shall be fixed to maintain the maximum speed.

#### 3.7.1.4 Restraints

Resilient restraints may be used to keep the snowthrower or machine in position during the tests given in 3.7.2 and 3.7.3.

#### 3.7.1.5 Number of units to be tested and sequence of tests

For the tests given in this International Standard, the following conditions shall apply.

- The manufacturer has the option of running one or any number of machines for tests (1) to (6).
- For tests (7) and (8), only one machine shall be used. No brake adjustment shall be made between tests.
- For tests (9) and (10), only one machine shall be used.
- Test (9) shall be followed by (10).

The tests are as follows:

- (1) Temperature of exposed surfaces (see 3.7.4).
- (2) Probe test (see 3.7.5).
- (3) Fuel tank overfill (see 3.7.8).
- (4) Fuel line (see 3.7.9).
- (5) Stability of riding vehicles (see 3.7.6).
- (6) Tilt of controls (see 3.7.10).

- (7) Parking brake system (see 3.7.7.3).
- (8) Service brake system (see 3.7.7.2).
- (9) Controls (see 3.7.3).
- (10) Structural integrity (see 3.7.2).

## 3.7.2 Structural integrity tests

### 3.7.2.1 Imbalance test

#### 3.7.2.1.1 Test procedure

The impeller imbalance in gram metres shall be determined by the formula:

$$700 D^3$$

where  $D$  is the outside diameter of the impeller, in metres.

This imbalance shall be created by removing or adding material until the required imbalance is obtained. The snowthrower shall be run in this imbalanced condition for 1 h.

#### 3.7.2.1.2 Test acceptance

The machine shall have failed this test if either of the following occurs:

- Loss or failure of any part or component that results in non-compliance with applicable parts of this International Standard.
- Movement of the controls from the positions selected at the beginning of test or shifting of the snow discharge guide more than 15° from the selected position.

### 3.7.2.2 Impact test

#### 3.7.2.2.1 Test equipment and conditions

An impact test fixture such as shown in figure 4 shall be used.

The snowthrower shall be positioned over the fixture as illustrated in figure 4.

The impact rod shall be injected into the impeller as indicated in figure 4.

#### 3.7.2.2.2 Test acceptance

The machine shall have failed this test if either of the following occurs:

- Breaking off of any part of the impeller. Shearing of devices provided to protect these parts shall not constitute test failure.
- Fracture or distortion of the impeller housing which will allow the probe (see figure 5) to contact a hazardous component or surface. Failure in the area of the 51 mm diameter test hole shall not constitute failure of this test.

### 3.7.2.3 Guards

#### 3.7.2.3.1 Test procedure

A smooth steel sphere having a diameter of 51 mm and weighing 0,54 kg shall be used.

If guards can be struck from above, the sphere shall be dropped vertically; if not, the sphere shall be suspended by a cord and allowed to fall from rest as a pendulum to strike the guards. In either case, the vertical travel of the sphere shall be 1,3 m.

One drop shall be made on each guard being tested.

For guards made of nonmetallic material, the test shall be repeated on both a) and b):

- a) A different sample(s) that has been in an air-oven for 7 h at a uniform temperature not less than 10 °C higher than the maximum operating temperature of the material measured under normal operating conditions, but not less than 70 °C. The sample shall not be tested until it has returned to room temperature.
- b) A sample(s) that has been conditioned at -20 °C for 7 h.

#### 3.7.2.3.2 Test acceptance

The guard shall have failed this test if either of the following occurs:

- Cracking that affects the functional strength of the part.
- Any condition that results in non-compliance with applicable parts of this International Standard.

Acceptance shall not be affected if a guard deformed during the test can be readily restored to its original shape.

## 3.7.3 Controls test

### 3.7.3.1 Test procedure

The engine shall be run for 15 min without interruption, with the controls in the disengaged position. This test is not required on a machine with an engine kill switch.

### 3.7.3.2 Test acceptance

The criteria for failure shall be the same as in 3.7.2.1.2. In addition, the machine shall have failed this test if the impeller rotates more than three revolutions in the 15 min test period.

## 3.7.4 Temperature of exposed surfaces

### 3.7.4.1 Limitations

All hot surfaces that exceed 66 °C and which might be contacted by the operator during normal starting, mounting, operating, or refuelling shall be indicated by a durable safety label (see 3.5 and 3.7) located adjacent to the surface, and be thermally insulated or shielded (if necessary) so that such surfaces will not exceed a temperature of 14 °C at 4,4 °C ambient. Surfaces that must comply are to be determined by the probe tests given in 3.7.5.



### 3.7.4.2 Test method

Surface temperatures shall be taken after the engine has operated under no-load for 1 h or until a steady-state temperature has been obtained. The temperature-measuring system shall enable the surface temperatures to be determined within 2 %. Temperature measurements shall be made at any temperature and corrected to 4,4 °C ambient.

The corrected surface temperature, in degrees Celsius, is equal to the measured surface temperature, in degrees Celsius + 4,4 °C (ambient temperature, in degrees Celsius).

### 3.7.5 Probe test

#### 3.7.5.1 Test procedure

CAUTION: The test is used to check moving parts and the following procedures should be conducted with the engine not running.

Simulate the operator during normal starting, mounting, and operation of the machine and insert the probe shown in figure 5 into all openings to its maximum depth 105 mm or until a force of 4,4 N is attained. As the probe is inserted, rotate and position it in all possible angles with the opening, attempting to contact the part or parts under test. The probe shall not be inserted beyond its length of 105 mm.

#### 3.7.5.2 Test acceptance

The machine shall be considered properly guarded if one of the following applies:

- a) The hazard cannot be contacted with the probe shown in figure 5, manoeuvred in any manner.
- b) The hazard is under and within the perimeter of the chassis elements, such as the frame, fender, and footrest, and the hazard cannot be reached with the probe shown in figure 5 manoeuvred as follows:
  - 1) From above the chassis elements, downward through openings in or between the elements;
  - 2) Underneath the chassis elements allowing only horizontal or downward probe movement, or both. Upward probe movement shall not be permitted.
- c) The hazard is controlled by an operator-presence control such that when functioning in accordance with a) and b), the probe cannot reach the hazard while simultaneously actuating the operator-presence control in its normal manner.

### 3.7.6 Stability requirements and tests

#### 3.7.6.1 General requirements

Stability determination and measurement shall be under static conditions.

**3.7.6.1.1** A 90 kg weight secured to the seat shall be used to simulate an operator. The centre of gravity of the weight shall be 150 mm above the lowest point of the operator-supporting

surface of the seat and 250 mm forward of the seat-back. If a seat-back is not used, this 250 mm forward measurement shall be made from the back of an actual operator when seated normally on the unit. If the seat is adjustable, it shall be positioned in the most forward position when checking forward stability and in the most rearward position when checking rearward stability.

**3.7.6.1.2** For machine stability determination, ballast shall be added only when the manufacturer designates that its use is required on the machine.

Lawn riding tractors and lawn and garden riding tractors shall be tested with the snowthrower attachment. All machines shall be tested with the snowthrower attached in its highest transport position.

**3.7.6.1.3** Pneumatic tyres shall be inflated to the pressure recommended in the operator's manual for normal operation.

**3.7.6.1.4** All wheels may be locked to prevent rotation about the axle.

**3.7.6.1.5** Steerable wheels shall be held in the straight-ahead position.

**3.7.6.1.6** The stability requirements shall apply for all tyre combinations on all wheel tread settings approved by the machine manufacturer.

#### 3.7.6.2 Test procedure

The stability of the machine shall be determined as follows.

Place the machine, supported on its wheels on a variable-slope single plane (tilt table) with a friction surface under the wheels equivalent to a 16- or 36-grit abrasive material. The table shall be tilted until

- a) a lift-off of the upper wheels of the machine occurs; or
- b) the minimum angle for acceptance as specified in 3.7.6.3 is attained.

Position the machine on the tilt table as follows:

- Longitudinal: The longitudinal centreline of the machine shall be perpendicular to the intersection line of the lowest edge of the table and a horizontal plane. Position the machine first with its front end on the downhill side and then with its rear end on the downside.
- Lateral: The longitudinal centreline of the machine shall be parallel to the intersection line of the lowest edge of the table and a horizontal plane. Position the machine first with its right side on the downhill side and then with its left side on the downhill side.

#### 3.7.6.3 Test acceptance

##### 3.7.6.3.1 Lift-off

Lift-off is considered to have occurred when a strip of 20 gauge steel, 51 mm wide, can be pulled from or moved under any tyre with a force of 9 N or less.

### 3.7.6.3.2 Longitudinal test acceptance

The angle of the tilt table with the machine positioned as in 3.7.6.2 shall be a minimum of 20° (36,4 % slope), with either end downhill before lift-off occurs.

### 3.7.6.3.3 Lateral test acceptance

The angle of the tilt table with the machine positioned as in 3.7.6.2 shall be a minimum of 20° (36,4 % slope), with either side downhill before lift-off occurs.

## 3.7.7 Braking requirements and tests

### 3.7.7.1 General requirements

Braking system requirements shall apply to the machine and snowthrower combination. For these tests, the machine shall be equipped with the tyres offered by the manufacturer that provide the least tread area in contact with the test surface. Ballast shall be added only when the manufacturer designates that its use is required on the machine.

### 3.7.7.2 Service brake system

#### 3.7.7.2.1 Requirements

The machine shall be equipped with a means capable of stopping its motion in both directions in a braking distance of 189 mm for each kilometre per hour up to a maximum machine velocity of 12,9 km/h. (For example, a machine moving at 8 km/h must stop in 1,5 m.)

For maximum machine velocities in excess of 12,9 km/h, use the formula:

$$L = \frac{V^2}{68}$$

where

$L$  is the stopping distance, in metres;

$V$  is the test velocity, in kilometres per hour.

This test shall be performed with a maximum force of 222 N applied to the pedal.

#### 3.7.7.2.2 Test procedure

**3.7.7.2.2.1** Test stops shall be conducted on a substantially level (not to exceed +1 % grade), dry, smooth, hard-surfaced roadway of concrete (or other surface with equivalent coefficient of surface friction) that is free from loose material.

**3.7.7.2.2.2** An operator with a minimum mass of 90 kg shall be seated on the machine during the test.

**3.7.7.2.2.3** When testing a machine equipped with separate clutch and brake control means, the clutch shall be disengaged simultaneously with the brake engagement.

**3.7.7.2.2.4** The snowthrower attachment shall be in the highest transport position.

**3.7.7.2.2.5** A force of 890 N shall be applied to the foot-brake pedal prior to the service brake test.

### 3.7.7.3 Parking brake system

#### 3.7.7.3.1 Requirement

The machine shall be equipped with a parking brake system which shall hold the machine in any direction when parked on a 16,7° (30 %) slope.

#### 3.7.7.3.2 Test procedure

**3.7.7.3.2.1** The tests shall be conducted on a smooth, flat surface with tractive conditions equivalent to resting on a 16- to 36-grit abrasive material.

**3.7.7.3.2.2** The transmission speed selector shall be in neutral with the engine shut off.

#### 3.7.7.3.2.3 Tests shall be run with

- a) the 90 kg weight positioned as in 3.7.6.1.1 for forward stability;
- b) without the 90 kg weight or the operator in position.

**3.7.7.3.2.4** The snowthrower shall be in the lowered position.

## 3.7.8 Fuel tank overfill test

### 3.7.8.1 Test procedure

With the machine on a level plane, the fuel tank inlet shall be overfilled by 100 ml of liquid within 5 s.

### 3.7.8.2 Test liquid

The test liquid shall be nonflammable and approximately the same viscosity as the fuel intended for use. Trichlorethane or the equivalent can be used.

### 3.7.8.3 Test acceptance

The machine shall have failed this test if any of the following occurs:

- The test liquid passes through the projected exhaust outlet area.
- The test liquid collects on the machine.
- The test liquid comes in contact with high-tension ignition cables or any non-insulated electrical component.

## 3.7.9 Fuel line axial pull test

Fuel lines shall not pull off fittings or fail when subjected to a 44 N axial pull test. The test is to be performed with the test

liquid in the line. This test is not required of short fuel lines held in position by compression.

**3.7.10 Tilt test for controls**

The control position shall not be affected by tilting of the machine, snowthrower, or combination of machine and snowthrower.

**3.7.10.1 Test procedure**

This test shall be conducted according to the stability test procedure in 3.7.6.2.

**3.7.10.2 Inactivation of controls**

Controls shall be placed in the stop, disengaged, or lift position (or other inactive position).

**3.7.10.3 Test acceptance**

Controls shall not move to the run, engaged, lowered, or other activating position at the extreme tilt specified for stability acceptance in 3.7.6.3.

**3.8 Safety instructions**

A durable label shall be provided to inform the user of the potential hazards that may be encountered in the normal operation and servicing of the snowthrower and power-driven attachments.

Similar instructions shall also be included in the operator's manual, supplied by the manufacturer as pertinent instructions for safe operation, such as shown in annex A.

If ballast is required on the machine, a durable label shall be affixed to the attachment stating this.

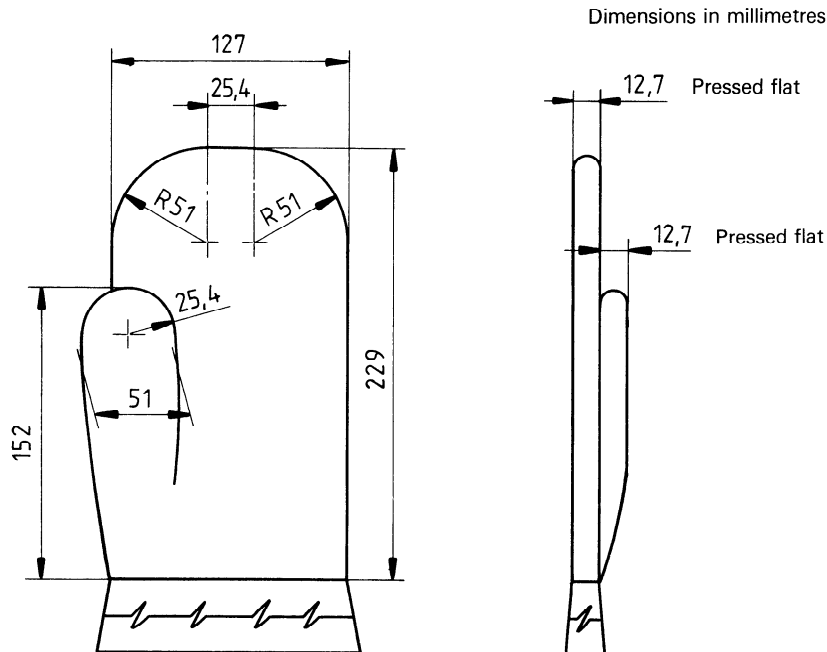

NOTES:

- 1) All dimensions are approximate, without hand in glove.
- 2) Material shall be a buckskin outer shell with knit liner.

**Figure 1 — Arctic mitten**

Dimensions in millimetres

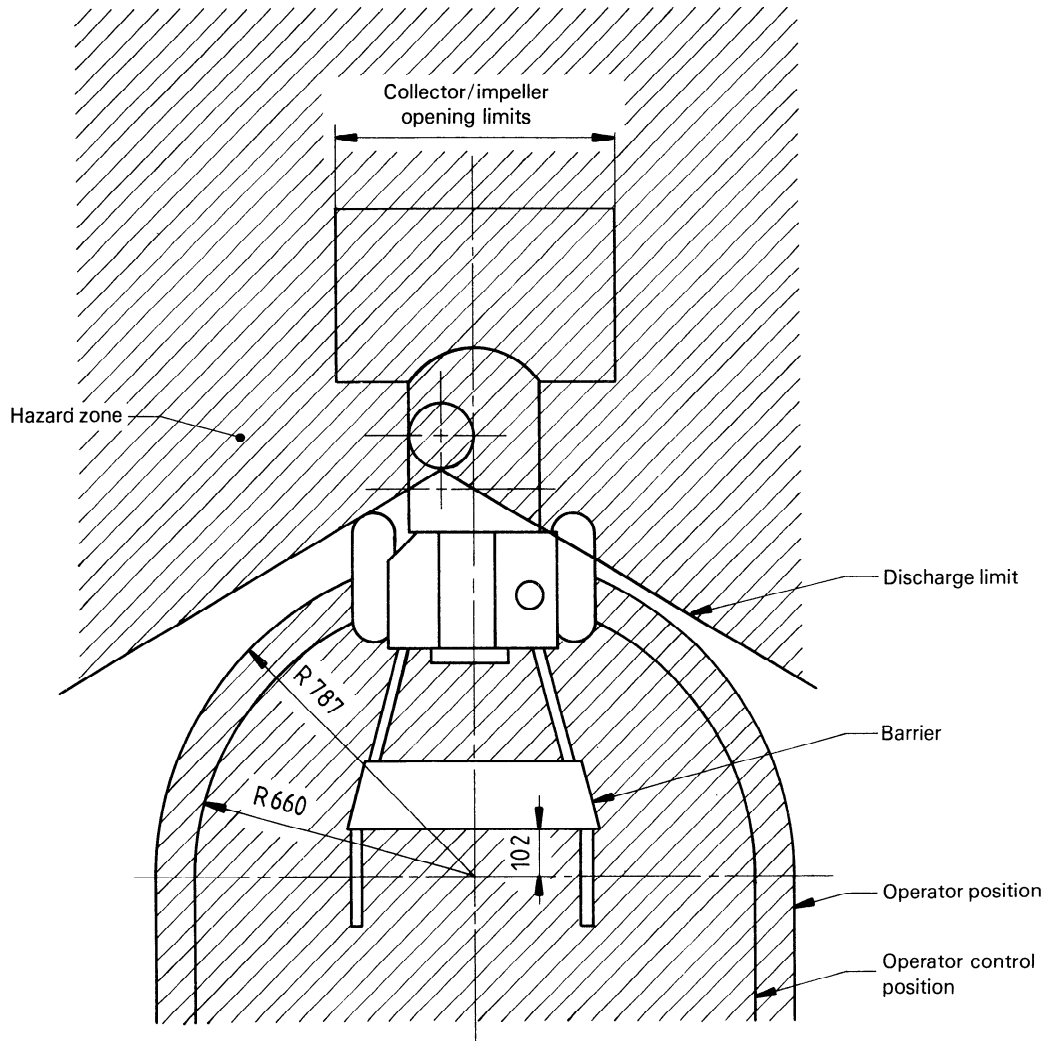

NOTE — Discharge limit shall be determined by a line tangent to or in line with the inside rear wall of the discharge guide, in the extreme left-hand and right-hand position. The operator position shall not intersect the hazard zone.

a) Walk-behind snowthrowers — Top view

Figure 2 — Operator position, operator control position and hazard zone for walk-behind and ride-on snowthrowers

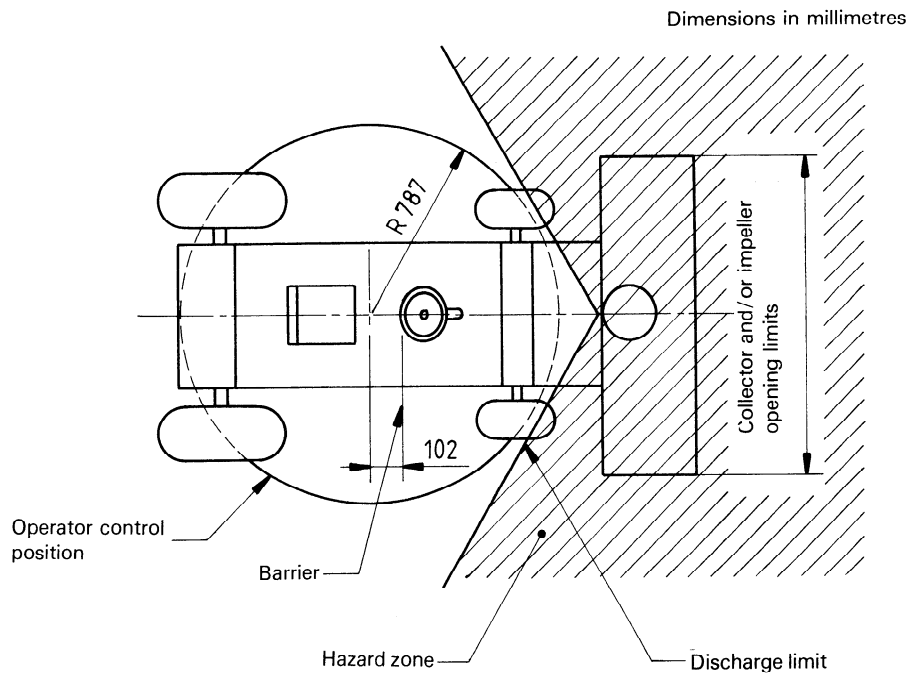

NOTE — Seat and steering-wheel shall be in the most forward position. Discharge limit shall be determined by a line tangent to or in line with the inside rear wall of the discharge guide, in the extreme left hand and right-hand position. The operator position shall not intersect the hazard zone.

**b) Ride-on snowthrower — Top view**

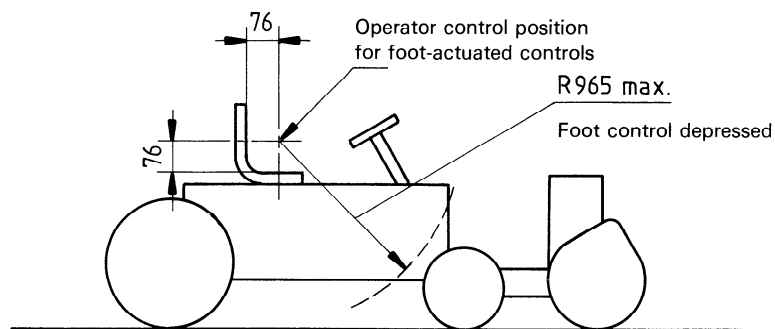

**c) Ride-on snowthrower — Side view**

Figure 2 (continued)

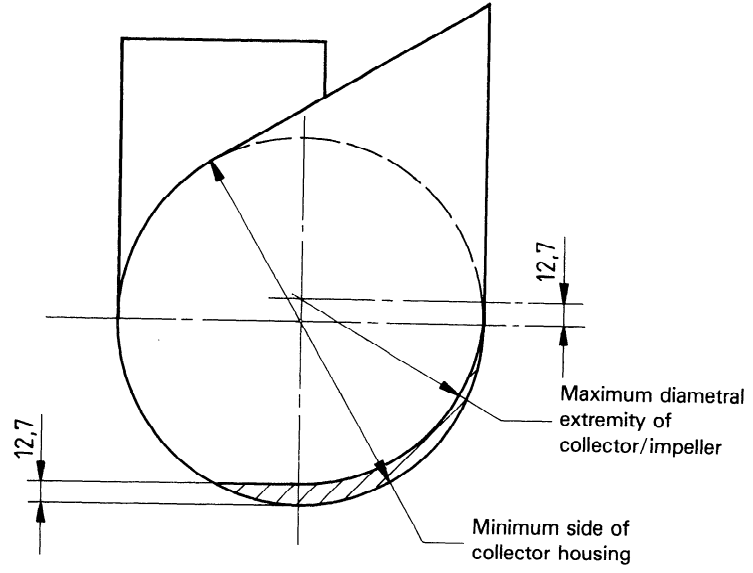
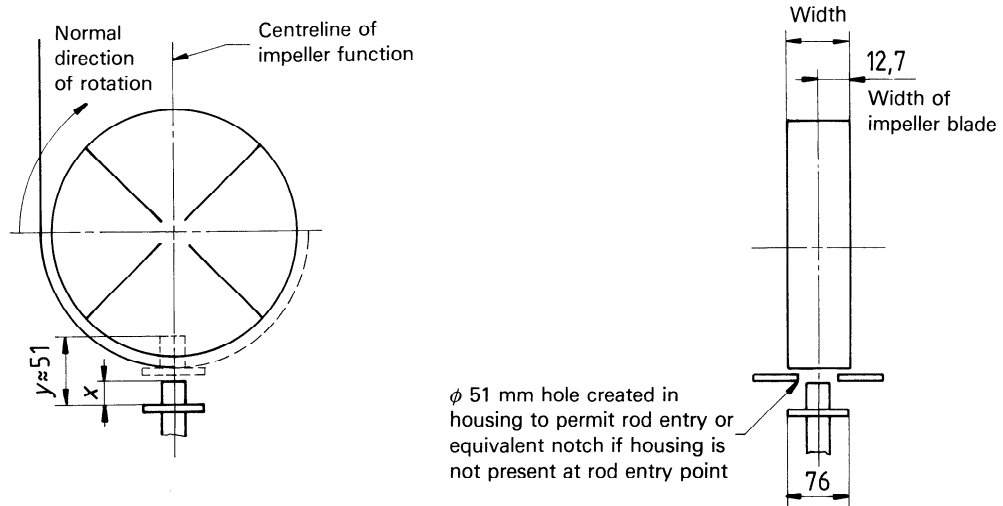
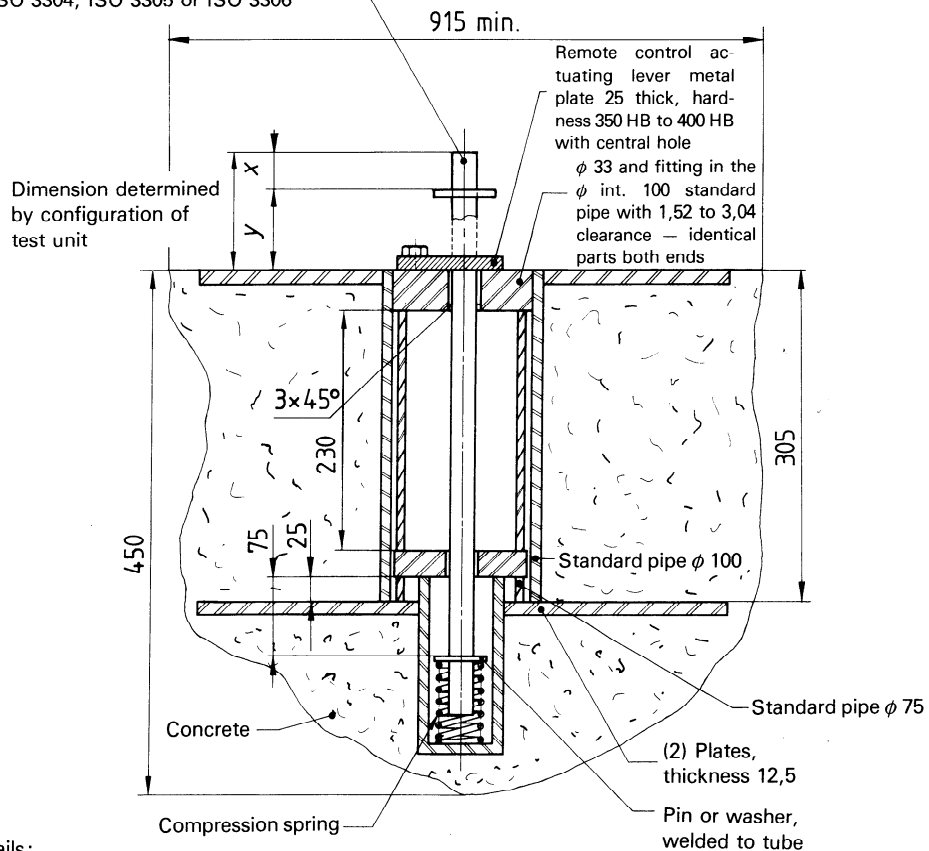

Figure 3 – Snowthrower housing

Dimensions in millimetres



Welded or seamless steel tube 30 × 3  
(see ISO 4200), grade R28 in accordance  
with ISO 3304, ISO 3305 or ISO 3306



Details:

free length: 165  
wire diameter: 3,2  
total number of coils: 11,75  
mean diameter: 35  
spring rate: 2,27 N/mm  
ends ground and squared

NOTE —  $x$  dimensions determined by each design tested to cause the washer to stop the tip of a 25,4 mm diameter rod 25 mm inside the periphery of the blade tip path.  $y$ -rod to be cocked to allow approximately 51 mm of travel of rod to full injection position.

Figure 4 — Impact test fixture

Dimensions in millimetres

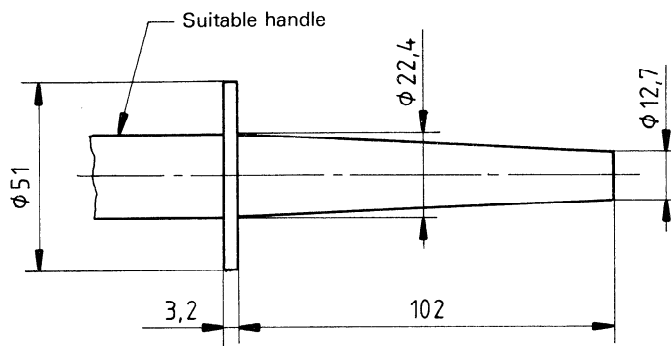

Figure 5 — Probe



## Annex A (normative)

### Safety instructions for walk-behind and ride-on snowthrowers

The safe operating practices detailed in this annex are not exhaustive. The safety instructions shall be provided with each machine, tailored to the specific snowthrower design.

#### A.1 Training

**A.1.1** Read the operating and service instruction manual carefully. Be thoroughly familiar with the controls and the proper use of the equipment. Know how to stop the unit and disengage the controls quickly.

**A.1.2** Never allow children to operate the equipment. Never allow adults to operate the equipment without proper instruction.

**A.1.3** Keep the area of operation clear of all persons, particularly small children, and pets.

**A.1.4** Exercise caution to avoid slipping or falling, especially when operating in reverse.<sup>1)</sup>

#### A.2 Preparation

**A.2.1** Thoroughly inspect the area where the equipment is to be used and remove all doormats, sleds, boards, wires, and other foreign objects.

**A.2.2** Disengage all clutches and shift into neutral before starting the engine.

**A.2.3** Do not operate the equipment without wearing adequate winter garments. Wear footwear which will improve footing on slippery surfaces.

**A.2.4** Handle fuel with care; it is highly flammable.

- a) Use an approved fuel container.
- b) Never add fuel to a running or hot engine.
- c) Fill fuel tank outdoors with extreme care. Never fill fuel tank indoors.
- d) Replace gasoline caps securely and wipe up spilled fuel.

**A.2.5** Use a grounded three-wire plug-in for all units with electric drive motors or electric starting motors.

**A.2.6** Adjust the collector housing height to clear gravel or crushed rock surface.

**A.2.7** Never attempt to make any adjustments while the engine is running (except where specifically recommended by manufacturer).

**A.2.8** Let engine and machine adjust to outdoor temperatures before starting to clear snow.

**A.2.9** The operation of any powered machine can result in foreign objects being thrown into the eyes. Always wear safety glasses or eye shields during operation or while performing an adjustment or repair.

#### A.3 Operation

**A.3.1** Do not put hands or feet near or under rotating parts. Keep clear of the discharge opening at all times.

**A.3.2** Exercise extreme caution when operating on or crossing gravel drives, walks, or roads. Stay alert for hidden hazards or traffic.

**A.3.3** After striking a foreign object, stop the engine, remove the wire from the spark-plug, thoroughly inspect the snowthrower for any damage, and repair the damage before restarting and operating the snowthrower.

**A.3.4** If the unit should start to vibrate abnormally, stop the engine and check immediately for the cause. Vibration is generally a warning of trouble.

**A.3.5** Stop the engine whenever you leave the operating position, before unclogging the collector/impeller housing or discharge guide, and when making any repairs, adjustments, or inspections.

**A.3.6** When cleaning, repairing, or inspecting, make certain the collector/impeller and all moving parts have stopped. Disconnect the spark-plug wire, and keep the wire away from the plug to prevent accidental starting. Disconnect the cable on electric motors.

**A.3.7** Do not run the engine indoors, except when starting it and for moving the snowthrower in or out of the building. Open the outside doors; exhaust fumes are dangerous.

<sup>1)</sup> Does not apply to ride-on snowthrowers.

**A.3.8** Do not clear snow across the face of slopes. Exercise extreme caution when changing direction on slopes. Do not attempt to clear steep slopes.

**A.3.9** Never operate the snowthrower without proper guards, plates or other safety protective devices in place.

**A.3.10** Never operate the snowthrower near glass enclosures, automobiles, window wells, etc. without proper adjustment of the snow discharge angle. Keep children and pets away.

**A.3.11** Do not overload the machine capacity by attempting to clear snow at too fast a rate.

**A.3.12** Never operate the machine at high transport speeds on slippery surfaces. Use care when reversing.

**A.3.13** Never direct discharge at bystanders or allow anyone in front of the unit.

**A.3.14** Disengage power to the collector/impeller when snowthrower is transported or not in use.

**A.3.15** Use only attachments and accessories approved by the manufacturer of snowthrower (such as wheel weights, counterweights, cabs, etc.).

**A.3.16** Never operate the snowthrower without good visibility or light. Always be sure of your footing, and keep a firm hold on the handles. Walk; never run.<sup>1)</sup>

**A.3.17** Do not carry passengers.<sup>2)</sup>

**A.3.18** Never operate the snowthrower without good visibility or light.<sup>2)</sup>

**A.3.19** Take all possible precautions when leaving the machine unattended. Disengage the power take-off, lower the attachments, shift into neutral, set the parking brake, stop the engine and remove the key.<sup>2)</sup>

## **A.4 Maintenance and storage**

**A.4.1** Check shear bolts, engine-mounted bolts, etc., at frequent intervals for proper tightness to be sure the equipment is in safe working condition.

**A.4.2** Never store the machine with fuel in the fuel tank inside a building where ignition sources are present such as hot water and space heaters, clothes dryers, etc. Allow the engine to cool before storing in any enclosure.

**A.4.3** Always refer to owner's guide instructions for important details if the snowthrower is to be stored for an extended period.

**A.4.4** Maintain or replace safety and instructions labels, as necessary.

**A.4.5** Run the machine a few minutes after throwing snow to prevent freeze-up of the collector/impeller.

1) Does not apply to ride-on snowthrowers.

2) Only applies to ride-on snowthrowers.

**Annex B**  
(informative)

**Bibliography**

ISO 3600:1981, *Tractors and machinery for agriculture and forestry — Operator manuals and technical publications — Presentation.*

ISO 3767-1:1982, *Tractors, machinery for agriculture and forestry, powered lawn and garden equipment — Symbols for operator controls and other displays — Part 1: Common symbols.*

ISO 3789-3:1982, *Tractors, machinery for agriculture and forestry, powered lawn and garden equipment — Location and method of operation of operator controls — Part 3: Controls for powered lawn and garden equipment.*

ISO 4254-1:1985, *Tractors and machinery for agriculture and forestry — Technical means for ensuring safety — Part 1: General.*

---

---

**UDC 629.11-479.1**

**Descriptors** : road vehicles, special road vehicles, snow ploughs, specifications, safety requirements, tests.

Price based on 23 pages

---

---