

---

---

**Resistance spot welding — Electrode  
holders —**

**Part 3:  
Parallel shank fixing for end thrust**

*Soudage par points par résistance — Porte-électrodes —*

*Partie 3: Emmanchement cylindrique pour poussée en bout*



**COPYRIGHT PROTECTED DOCUMENT**

© ISO 2016, Published in Switzerland

All rights reserved. Unless otherwise specified, no part of this publication may be reproduced or utilized otherwise in any form or by any means, electronic or mechanical, including photocopying, or posting on the internet or an intranet, without prior written permission. Permission can be requested from either ISO at the address below or ISO's member body in the country of the requester.

ISO copyright office  
Ch. de Blandonnet 8 • CP 401  
CH-1214 Vernier, Geneva, Switzerland  
Tel. +41 22 749 01 11  
Fax +41 22 749 09 47  
copyright@iso.org  
www.iso.org

# Contents

Page

<b>Foreword</b> .....	<b>iv</b>
<b>1 Scope</b> .....	<b>1</b>
<b>2 Normative references</b> .....	<b>1</b>
<b>3 Dimensions</b> .....	<b>1</b>
<b>4 Designation</b> .....	<b>1</b>
<b>5 Materials</b> .....	<b>2</b>
<b>6 Delivery conditions</b> .....	<b>2</b>
<b>7 Marking</b> .....	<b>2</b>

## Foreword

ISO (the International Organization for Standardization) is a worldwide federation of national standards bodies (ISO member bodies). The work of preparing International Standards is normally carried out through ISO technical committees. Each member body interested in a subject for which a technical committee has been established has the right to be represented on that committee. International organizations, governmental and non-governmental, in liaison with ISO, also take part in the work. ISO collaborates closely with the International Electrotechnical Commission (IEC) on all matters of electrotechnical standardization.

The procedures used to develop this document and those intended for its further maintenance are described in the ISO/IEC Directives, Part 1. In particular the different approval criteria needed for the different types of ISO documents should be noted. This document was drafted in accordance with the editorial rules of the ISO/IEC Directives, Part 2 (see [www.iso.org/directives](http://www.iso.org/directives)).

Attention is drawn to the possibility that some of the elements of this document may be the subject of patent rights. ISO shall not be held responsible for identifying any or all such patent rights. Details of any patent rights identified during the development of the document will be in the Introduction and/or on the ISO list of patent declarations received (see [www.iso.org/patents](http://www.iso.org/patents)).

Any trade name used in this document is information given for the convenience of users and does not constitute an endorsement.

For an explanation on the meaning of ISO specific terms and expressions related to conformity assessment, as well as information about ISO's adherence to the WTO principles in the Technical Barriers to Trade (TBT) see the following URL: [Foreword - Supplementary information](#)

The committee responsible for this document is ISO/TC 44, *Welding and allied processes*, SC 6, *Resistance welding and allied mechanical joining*.

This second edition cancels and replaces the first edition (ISO 8430-3:1988), which has been technically revised. The following changes have been made:

- in [Clause 5](#), the second paragraph has been updated and there is no longer a reference to ISO 1642;
- the figures have been updated to comply with the latest ISO style and to reflect the latest edition of ISO 1302.

ISO 8430 consists of the following parts, under the general title *Resistance spot welding — Electrode holders*:

- *Part 1: Taper fixing 1:10*
- *Part 2: Morse taper fixing*
- *Part 3: Parallel shank fixing for end thrust*

# Resistance spot welding — Electrode holders —

## Part 3: Parallel shank fixing for end thrust

### 1 Scope

This part of ISO 8430 specifies the dimensions and tolerances of resistance spot welding electrode holders (type C) without offset and with a facility for cable clamping, and where a clamp is used to fix the holder directly to the welding cylinder in multiple spot welding equipment.

### 2 Normative references

The following documents, in whole or in part, are normatively referenced in this document and are indispensable for its application. For dated references, only the edition cited applies. For undated references, the latest edition of the referenced document (including any amendments) applies.

ISO 1302, *Geometrical Product Specifications (GPS) — Indication of surface texture in technical product documentation*

ISO 3601-1, *Fluid power systems — O-rings — Part 1: Inside diameters, cross-sections, tolerances and designation codes*

ISO 5182:2008, *Resistance welding — Materials for electrodes and ancillary equipment*

ISO 5183-2, *Resistance spot welding — Electrode adaptors, male taper 1:10 — Part 2: Parallel shank fixing for end-thrust electrodes*

ISO 5821, *Resistance welding — Spot welding electrode caps*

ISO 5828, *Resistance welding equipment — Secondary connecting cables with terminals connected to water-cooled lugs — Dimensions and characteristics*

ISO 7285, *Pneumatic cylinders for mechanized multiple spot welding*

ISO 9313, *Resistance spot welding equipment — Cooling tubes*

### 3 Dimensions

The dimensions shall be in accordance with [Figure 1](#) and [Table 1](#).

### 4 Designation

The designations of electrode holders which comply with this part of ISO 8430 shall comprise the following information in the order given:

- a) the description block (i.e. “spot welding electrode holder”);
- b) a reference to this part of ISO 8430;
- c) the type of electrode holder (type C);
- d) the diameter,  $d_1$ , in millimetres;

## ISO 8430-3:2016(E)

e) the material of which the electrode holder is made, in accordance with ISO 5182.

**EXAMPLE** A type C (parallel shank fixing) spot welding electrode holder, of diameter  $d_1 = 16$  mm and material type A 2/1, shall be designated as follows:

Spot welding electrode holder ISO 8430-3-C-16-A 2/1

### 5 Materials

The material from which the electrode holder is made shall be in accordance with ISO 5182, preferably group A, type 2.

If a clamp is used, it shall be made of a non-magnetic material.

### 6 Delivery conditions

The fixing shall be protected against damage, e.g. by a coating of synthetic resin.

### 7 Marking

Electrode holders complying with this part of ISO 8430 shall be marked with the designation in accordance with [Clause 4](#), but excluding the description block and the reference number of this part of ISO 8430, for example:

C-16-A 2/1

Dimensions in millimetres,  
surface roughness values in micrometres

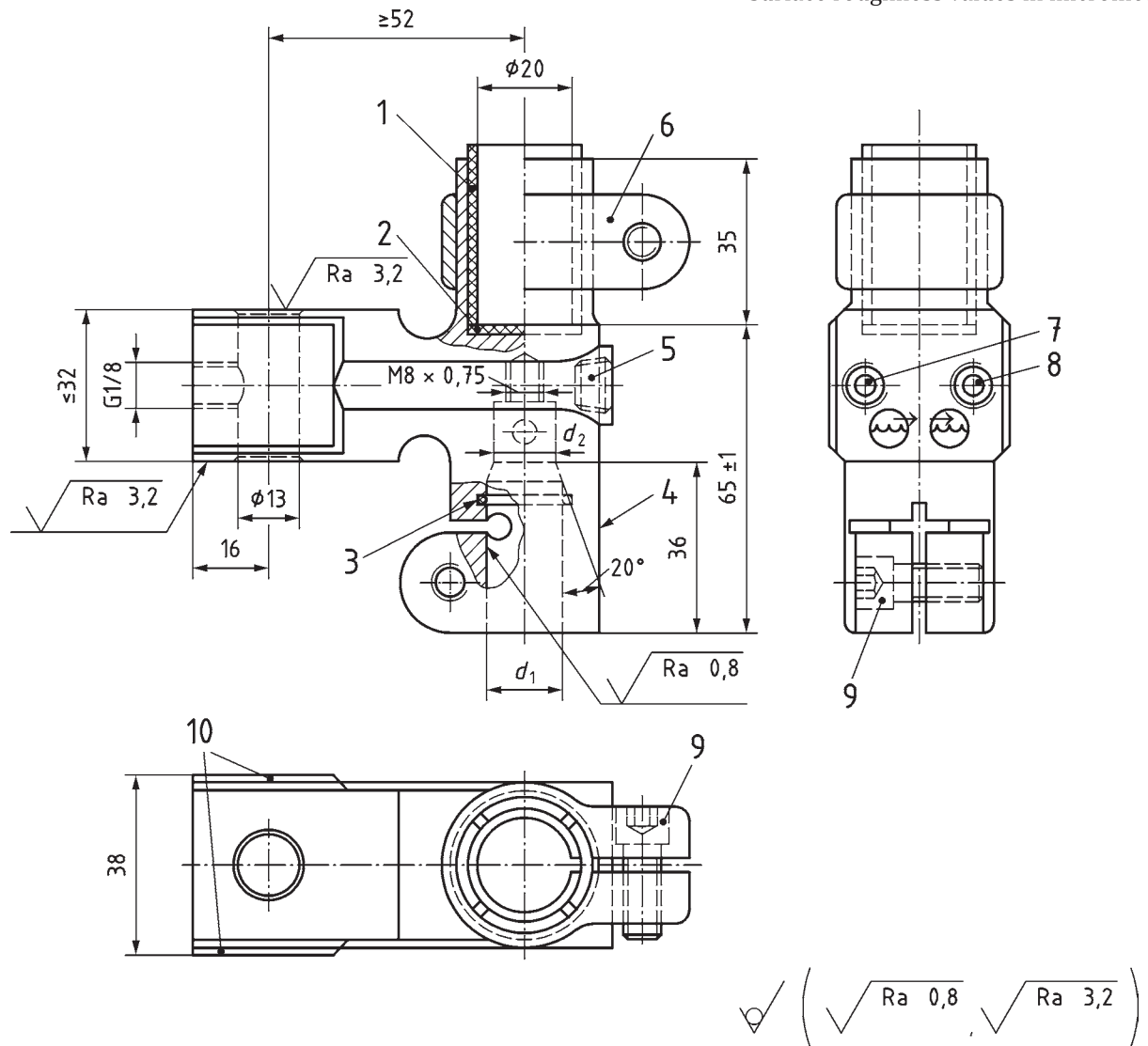

**Key**

- |   |                                 |
|---|---------------------------------|
| 1 insulation bush                       | 6 clamp                         |
| 2 insulation washer                     | 7 water inlet                   |
| 3 O-ring (see <a href="#">Table 1</a> ) | 8 water outlet                  |
| 4 designation mark                      | 9 hexagon socket head cap screw |
| 5 hexagon socket pipe plug              | 10 insulation plate             |

NOTE Surface roughness in accordance with ISO 1302.

**Figure 1 — Dimensions**

Table 1 — Dimensions

Dimensions in millimetres

$d_1$ H7	$d_2$	Size identification code of the O-ring <sup>a</sup>	Total length of cooling tube <sup>b</sup> for adaptors of	
			type C 3 <sup>c</sup>	type D 3 <sup>c</sup>
12,5	9,5	125 025	$l_5^c + 38$	$l_5^c + 43$
16	13	160 025		
20	17	200 025		
a	In accordance with ISO 3601-1.			
b	See ISO 9313.			
c	See ISO 5183-2.			



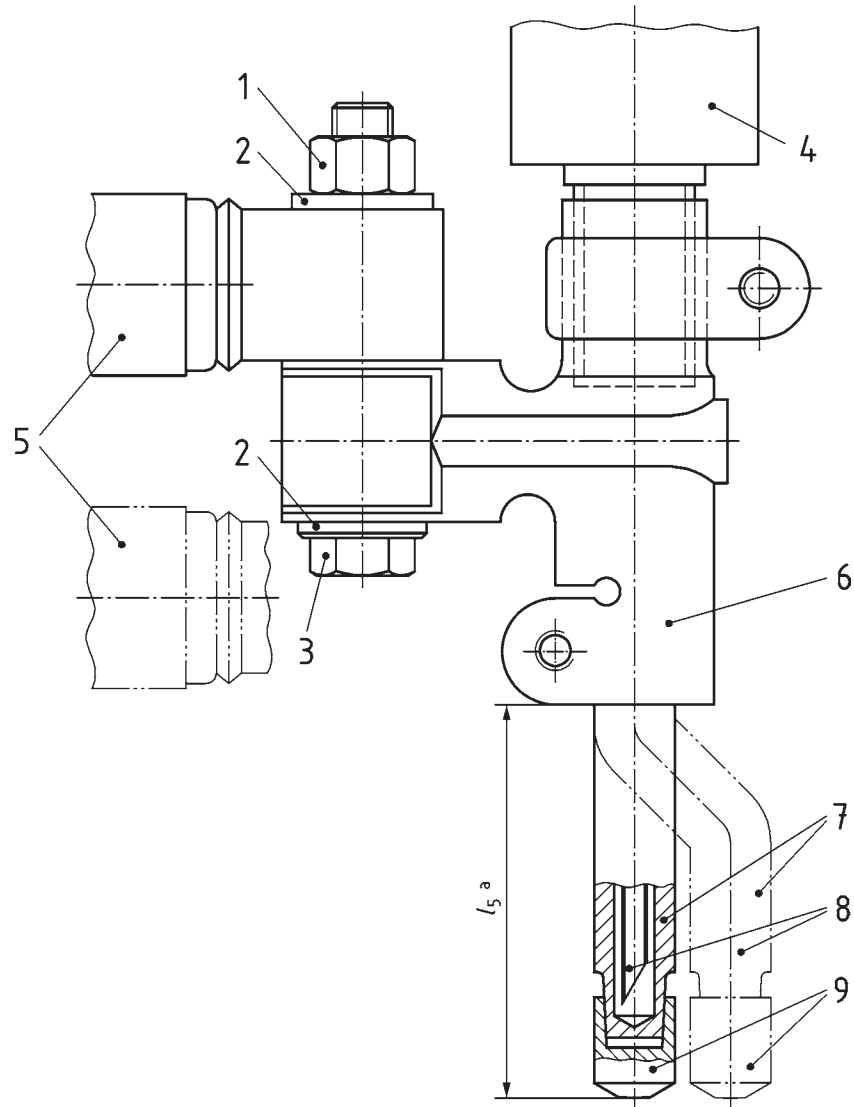

**Key**

- |   |   |   |   |
|---|---|---|---|
| 1 | nut M12   | 6 | electrode holder, see this part of ISO 8430 |
| 2 | washer, clearance diameter 13                                   | 7 | electrode adaptor, see ISO 5183-1           |
| 3 | bolt M12  | 8 | cooling tube type A, see ISO 9313           |
| 4 | welding cylinder, see ISO 7285                                  | 9 | electrode cap, see ISO 5821                 |
| 5 | secondary connection cable, see ISO 5828<br>(position optional) | a | see ISO 5183-2                              |

**Figure 2 — Example of assembly**

