

INTERNATIONAL
STANDARD

ISO
8370-1

First edition
1993-10-15

**Belt drives — Dynamic test to determine
pitch zone location —**

Part 1:
V-belts

*Transmissions par courroies — Méthode d'essai dynamique de
détermination de l'emplacement de la zone primitive d'une courroie —
Partie 1: Courroies trapézoïdales*



Reference number
ISO 8370-1:1993(E)

Foreword

ISO (the International Organization for Standardization) is a worldwide federation of national standards bodies (ISO member bodies). The work of preparing International Standards is normally carried out through ISO technical committees. Each member body interested in a subject for which a technical committee has been established has the right to be represented on that committee. International organizations, governmental and non-governmental, in liaison with ISO, also take part in the work. ISO collaborates closely with the International Electrotechnical Commission (IEC) on all matters of electrotechnical standardization.

Draft International Standards adopted by the technical committees are circulated to the member bodies for voting. Publication as an International Standard requires approval by at least 75 % of the member bodies casting a vote.

International Standard ISO 8370-1 was prepared by Technical Committee ISO/TC 41, *Pulleys and belts (including veebelts)*, Sub-Committee SC 1, *Veebelts and grooved pulleys*.

This first edition of ISO 8370-1, together with ISO 8370-2, cancels and replaces ISO 8370:1987, which has been technically revised.

ISO 8370 consists of the following parts, under the general title *Belt drives — Dynamic test to determine pitch zone location*:

- Part 1: *V-belts*
- Part 2: *V-ribbed belts*

© ISO 1993

All rights reserved. No part of this publication may be reproduced or utilized in any form or by any means, electronic or mechanical, including photocopying and microfilm, without permission in writing from the publisher.

International Organization for Standardization
Case Postale 56 • CH-1211 Genève 20 • Switzerland

Printed in Switzerland

Introduction

A V-belt pulley groove is defined by its effective width or datum width.

When a specific belt is placed in the groove, it will operate with a pitch zone at a finite position relative to the groove. This position needs to be defined for power transmission design calculations.

Belt drives — Dynamic test to determine pitch zone location —

Part 1: V-belts

1 Scope

This part of ISO 8370 specifies a dynamic method of determining the location of the pitch zone of a single V-belt in a single pulley groove or of a joined V-belt in a multiple pulley which is expressed as an effective line differential b_e (see figures 1 and 2), or of a single V-belt in a single pulley groove which is expressed as a datum line differential b_d (see figure 3). A hexagonal belt can be treated as a single V-belt.

2 Normative reference

The following standard contains provisions which, through reference in this text, constitute provisions of this part of ISO 8370. At the time of publication, the edition indicated was valid. All standards are subject to revision, and parties to agreements based on this part of ISO 8370 are encouraged to investigate the possibility of applying the most recent edition of the standard indicated below. Members of IEC and ISO maintain registers of currently valid International Standards.

ISO 1081:1980, *Drives using V-belts and grooved pulleys — Terminology.*

3 Definitions

For the purposes of this part of ISO 8370, the definitions given in ISO 1081 apply.

4 Principle

Calculation of the pitch diameter of the belt operating in the pulley on a test fixture by measuring the rotational frequency of the pulley and either the belt velocity over a straight span or the centre distance

between the pulleys and the time of the belt rotation, and calculation of the effective line differential or the datum line differential.

5 Apparatus

5.1 Test fixture, with two pulleys of equal diameter, of the dimensions specified for the measuring of the specific belt according to the appropriate International Standard. The centre distance between the pulley shafts shall be adjustable to accommodate the required belt lengths of a specific belt and a means of applying the measuring force specified in the appropriate International Standard shall be provided. A clamping device shall be provided to lock the centre distance.

The fixture shall include a means of mechanically rotating one of the pulleys at a reasonable speed. While the specific speed is not critical, it shall be fast enough to ensure smooth operation. About 1 000 r/min is suggested. A fixture shall be provided for measuring the rotational frequency and either the velocity of the belt or the centre distance between the pulleys and the time of rotation of the belt.

6 Procedure

Fit the belt onto the fixture described in clause 5. Apply the measuring force as specified in the appropriate International Standard to tension the belt. Start the machine and allow it to operate for 5 min to seat the belt fully in the pulleys.

After the run-in period, clamp the movable shaft in place so that the centre distance remains constant.

With the machine operating, take accurate and simultaneous measurements of the rotational frequency of

where

b_d is the datum line differential, in millimetres;

d_d is the datum diameter, in millimetres;

d_p is the pitch diameter, in millimetres.

If the pitch diameter of the belt operating in the pulley (determined by the location of the pitch zone of the belt) is smaller than the datum diameter described by the pulley, the datum line differential will be positive. A negative value for the datum line differential means the pitch zone of the belt is at a diameter larger than the datum diameter.

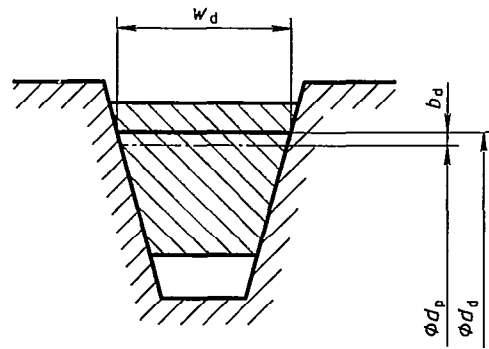

Figure 3 — Datum line differential

UDC 621.85.052.42:620.1

Descriptors: belt drives, belts, power transmission belts, V-belts, tests, dynamic tests, determination, geometric characteristics, rules of calculation.

Price based on 3 pages
