**Rubber compounding ingredients —
Sulfur — Methods of test**

Ingrédients de mélange du caoutchouc — Soufre — Méthodes d'essai



Reference number
ISO 8332:2011(E)

© ISO 2011



COPYRIGHT PROTECTED DOCUMENT

© ISO 2011

All rights reserved. Unless otherwise specified, no part of this publication may be reproduced or utilized in any form or by any means, electronic or mechanical, including photocopying and microfilm, without permission in writing from either ISO at the address below or ISO's member body in the country of the requester.

ISO copyright office
Case postale 56 • CH-1211 Geneva 20
Tel. + 41 22 749 01 11
Fax + 41 22 749 09 47
E-mail copyright@iso.org
Web www.iso.org

Published in Switzerland

Contents

Page

Foreword	v
Introduction.....	vi
1 Scope	1
2 Normative references	1
3 Physical and chemical properties	1
4 Determination of total sulfur content	2
4.1 Principle	2
4.2 Reagents	2
4.3 Procedure	2
4.4 Expression of results	3
4.5 Precision	3
5 Determination of sieve residue	3
5.1 Principle	3
5.2 Method A	4
5.3 Method B	5
6 Determination of oil content of oil-treated sulfur	6
6.1 Principle	6
6.2 Hexane procedure	7
6.3 Sulfur-saturated hexane procedure	7
7 Determination of insoluble-sulfur content	8
7.1 Principle	8
7.2 Reference procedure using toluene	8
7.3 Alternative procedure using carbon disulfide	9
8 Determination of thermal reversion of insoluble sulfur	10
8.1 General	10
8.2 Method A	10
8.3 Method B	13
8.4 Precision	16
9 Determination of loss in mass at 80 °C	16
9.1 Principle	16
9.2 Apparatus	16
9.3 Procedure	17
9.4 Expression of results	17
9.5 Precision	17
10 Determination of ash at 850 °C to 900 °C	18
10.1 Principle	18
10.2 Apparatus	18
10.3 Procedure	18
10.4 Expression of results	18
10.5 Precision	18
11 Determination of acidity	19
12 Determination of arsenic content	19
13 Test report	19
Annex A (informative) Typical values of the properties of sulfur used as a rubber compounding ingredient	20

Annex B (informative) Precision	22
Bibliography	25

© ISO 2011 – All rights reserved

Foreword

ISO (the International Organization for Standardization) is a worldwide federation of national standards bodies (ISO member bodies). The work of preparing International Standards is normally carried out through ISO technical committees. Each member body interested in a subject for which a technical committee has been established has the right to be represented on that committee. International organizations, governmental and non-governmental, in liaison with ISO, also take part in the work. ISO collaborates closely with the International Electrotechnical Commission (IEC) on all matters of electrotechnical standardization.

International Standards are drafted in accordance with the rules given in the ISO/IEC Directives, Part 2.

The main task of technical committees is to prepare International Standards. Draft International Standards adopted by the technical committees are circulated to the member bodies for voting. Publication as an International Standard requires approval by at least 75 % of the member bodies casting a vote.

Attention is drawn to the possibility that some of the elements of this document may be the subject of patent rights. ISO shall not be held responsible for identifying any or all such patent rights.

ISO 8332 was prepared by Technical Committee ISO/TC 45, *Rubber and rubber products*, Subcommittee SC 3, *Raw materials (including latex) for use in the rubber industry*.

This fourth edition cancels and replaces the third edition (ISO 8332:2006), in which the following changes have been made.

- a) the dry procedure for the determination of the sieve residue has been deleted;
- b) the precision data have been moved to informative Annex B;
- c) old Annex B, giving guidance on the use of precision results, has been deleted.

Introduction

Sulfur appears in three allotropic forms:

- a) rhombic;
- b) monoclinic;
- c) amorphous (insoluble in CS₂).

In rubber compounding practice, forms a) and c) are used. Both types may be used in their natural form or may be coated. The coating can be oil, or MgCO₃, or silica, or some other material that aids dispersion in the rubber compound. Sulfur is available in varying degrees of fineness.

Amorphous sulfur (insoluble sulfur) is usually produced in industry through the rapid cooling of molten sulfur and can also contain rhombic sulfur (soluble sulfur), as insoluble sulfur tends to revert back to the rhombic state on storage. Insoluble sulfur is important in the rubber industry as a vulcanizing agent since, when it is used, it can prevent rubber compounds from blooming during storage or during a production process without any adverse impact on the vulcanization process. Grades containing various amounts of insoluble sulfur are available to control blooming today (see Annex A).

Rubber compounding ingredients — Sulfur — Methods of test

WARNING — Persons using this International Standard should be familiar with normal laboratory practice. This standard does not purport to address all of the safety problems, if any, associated with its use. It is the responsibility of the user to establish appropriate safety and health practices and to ensure compliance with any national regulatory conditions.

1 Scope

This International Standard specifies methods of test for determining the main physical and chemical properties of sulfur used for compounding dry rubber.

NOTE Typical levels for the relevant properties of sulfur for use as a rubber compounding ingredient are contained in Annex A, for information only.

2 Normative references

The following referenced documents are indispensable for the application of this document. For dated references, only the edition cited applies. For undated references, the latest edition of the referenced document (including any amendments) applies.

ISO 565, *Test sieves — Metal wire cloth, perforated metal plate and electroformed sheet — Nominal sizes of openings*

ISO 2590, *General method for the determination of arsenic — Silver diethyldithiocarbamate photometric method*

ISO 3704, *Sulphur for industrial use — Determination of acidity — Titrimetric method*

ISO 3705, *Sulphur for industrial use — Determination of arsenic content — Silver diethyldithiocarbamate photometric method*

ISO 4793, *Laboratory sintered (fritted) filters — Porosity grading, classification and designation*

ISO 15528, *Paints, varnishes and raw materials for paints and varnishes — Sampling*

3 Physical and chemical properties

After sampling with a stainless-steel sampling tool in accordance with ISO 15528, the physical and chemical properties of sulfur used as a rubber compounding ingredient shall be determined by the following test methods.

Property	Test method
Total sulfur [% (by mass)]	Clause 4
Fineness (sieve residue) [% (by mass)]	Clause 5
Oil content [% (by mass)]	Clause 6
Insoluble sulfur [% (by mass)]	Clause 7
Thermal reversion (%)	Clause 8
Loss in mass at 80 °C [% (by mass)]	Clause 9
Ash [% (by mass)]	Clause 10
Acidity [as H ₂ SO ₄ , % (by mass)]	Clause 11 (ISO 3704)
Arsenic (mg/kg)	Clause 12 (ISO 3705 and ISO 2590)

NOTE Determination of the arsenic content is not necessary when a sulfur sample is produced through hydro-desulfurization from natural sources such as oil or natural gas.

4 Determination of total sulfur content

4.1 Principle

The sulfur in a test portion is first converted to thiosulfate, to which an excess volume of iodine solution is added, then determined by back titration with a sodium thiosulfate solution.

4.2 Reagents

During the analysis, use only reagents of recognized analytical grade and only distilled water or water of equivalent purity.

4.2.1 Sodium sulfite solution, 50 g/dm³. Dissolve 50 g of anhydrous sodium sulfite in 1 dm³ of water.

4.2.2 Standard volumetric iodine solution, $c(I_2) = 0,05 \text{ mol/dm}^3$, freshly prepared and standardized.

4.2.3 Standard volumetric sodium thiosulfate solution, 0,1 mol/dm³ solution, freshly prepared and standardized.

4.2.4 Formaldehyde solution, 37 % (by mass).

4.2.5 Glacial acetic acid.

4.2.6 Wetting-out solution, consisting of a 20 g/dm³ solution of an alkylaryl sulfonate (e.g. sodium dodecylbenzene sulfonate) in water.

4.2.7 Soluble-starch solution, freshly prepared.

4.3 Procedure

4.3.1 Weigh, to the nearest 0,1 mg, 0,2 g of the sulfur sample (m_0) on a tared watch glass. Using a Pasteur pipette, add approximately 1 cm³ of wetting-out solution (4.2.6). Transfer the mixture to a 200 cm³ flask via a small glass funnel using a stream of the sodium sulfite solution (4.2.1) from a 50 cm³ measuring cylinder. Add a few antibumping granules, fix a reflux condenser in position and place the whole on an electrically heated oil-bath.

Adjust the oil-bath temperature to 130 °C. Stir the contents of the flask for 1 h under reflux, and complete the reaction. If undissolved sulfur remains visible in the flask, continue the heating process as long as necessary. Wash the walls of the condenser with water and collect the washings in the flask. Cool the contents of the flask to 25 °C. Transfer the contents of the flask to a 100 cm³ volumetric flask. Make up to the mark with water.

NOTE Reaction of 20 % oil-treated sulfur takes about 3 h to 4 h.

4.3.2 Place exactly 30 cm³ of iodine solution (4.2.2) into a 200 cm³ conical flask from a burette, and add 10 cm³ of acetic acid (4.2.5) to it using a pipette.

4.3.3 Place 10 cm³ of test solution from the 100 cm³ volumetric flask in 4.3.1, using a pipette, into a 100 cm³ beaker. Add 2 cm³ of formaldehyde solution (4.2.4) and stir using a magnetic stirrer for 2 min. After a 5-min rest, add the solution to the conical flask in 4.3.2. Wash the walls of the beaker and add the washings to the conical flask. While swirling the conical flask, add 1 cm³ of the starch solution (4.2.7) and titrate with the sodium thiosulfate solution (4.2.3) until the dark-blue colour vanishes. V_1 is the volume, in cubic centimetres, of the sodium thiosulfate solution used for this titration.

4.3.4 Carry out a blank determination omitting the test portion. V_0 is the volume, in cubic centimetres, of the sodium thiosulfate solution used for this titration.

4.4 Expression of results

Calculate the total sulfur content (TS_{ts}), expressed as a percentage by mass, from the following formula:

$$TS_{ts} = \frac{(V_0 - V_1)}{m_0} \times c \times 10 \times 3,2$$

where

V_0 is the volume, in cubic centimetres, of sodium thiosulfate solution (4.2.3) used to titrate the blank (see 4.3.4);

V_1 is the volume, in cubic centimetres, of sodium thiosulfate solution (4.2.3) used to titrate the test portion (see 4.3.3);

c is the exact concentration, in moles of Na₂S₂O₃ per cubic decimetre, of the sodium thiosulfate solution (4.2.3);

m_0 is the mass, in grams, of the test portion (see 4.3.1).

4.5 Precision

See B.3.2.

5 Determination of sieve residue

5.1 Principle

A test portion is passed through sieves of specified mesh openings, using water to assist in the sieving process, and the residue retained is dried and weighed. Two methods are specified:

- method A, which uses a sieve in a metal funnel and a high-pressure water jet (see Figure 1);
- method B, in which water is poured over the sulfur on the sieve while the sieve is shaken manually.

5.2 Method A

5.2.1 Apparatus

5.2.1.1 **Metal funnel (A)**, about 200 mm in diameter, terminating at the foot in a short cylindrical outlet (see Figure 1) in which is inserted a shallow removable cup (B), on the bottom of which a wire-cloth sieve (C) (5.2.1.2) is soldered; this is 25 mm in diameter. Water under pressure is supplied by a tube (D) fitted with a nozzle designed to discharge a spreading jet through the sieve; the distance of the orifice from the sieve can be adjusted. The recommended minimum water pressure is 200 kPa (2 bar). The tube is provided with a filter (H) to remove any solid particles from the water; this filter shall be made from wire cloth at least as fine as the sieve (C), and shall be sufficiently large to prevent undue loss of pressure.

A similar arrangement is provided for another tube (E) used to supply a gentle stream of water for wetting the powder and keeping the volume of the liquid in the funnel constant during the test.

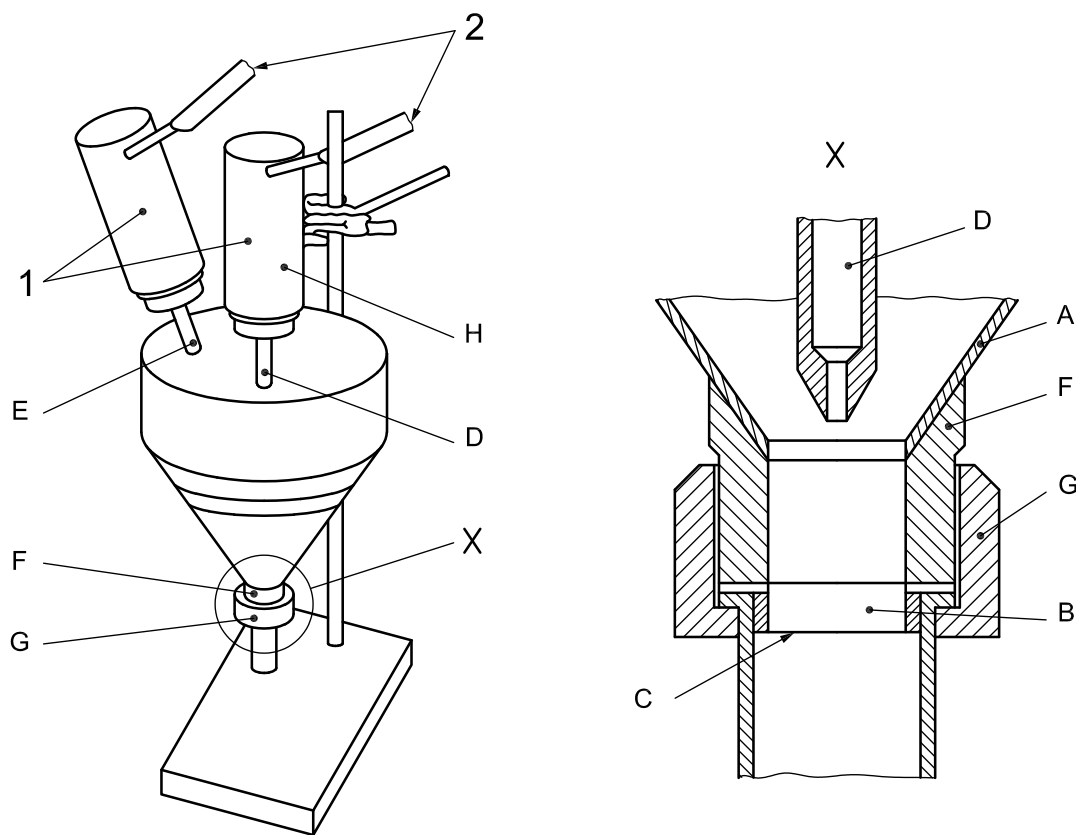

- Key**
 1 filters
 2 water inlets

A to E and H are as described in 5.2.1.1.
 F and G are described in 5.2.2.

Figure 1 — Apparatus for determination of sieve residue (wet procedure: method A)

5.2.1.2 **Two sieves**, of woven metal-wire cloth, in accordance with ISO 565, having openings of nominal width 180 µm and 125 µm, respectively.

5.2.1.3 **Flat brush**, of camel hair or equivalent, approximately 7 mm wide.

5.2.1.4 **Desiccator**.

5.2.2 Procedure

Mount a sieve cup (B) with a sieve (C) with the required openings (i.e. one of the two sieves specified in 5.2.1.2), or with openings as agreed between the interested parties, in the apparatus. Allow water to flow through it for 3 min from tubes D and E. Examine the sieve for particles; if none are observed, the apparatus is ready for use. Dry the sieve cup at $80\text{ °C} \pm 2\text{ °C}$ for 30 min. Allow it to cool in a desiccator (5.2.1.4) and then weigh it to the nearest 0,1 mg. Repeat this operation until the change in mass is reduced to not more than 1 mg, record the mass of the sieve cup and mount it in the apparatus, holding it in place by the union nut (G). Weigh out, to the nearest 0,1 g, about 25 g (m_1) of the sample. Make into a slurry with 300 cm^3 of a 20 g/dm^3 solution of alkylaryl sulfonate in water in a beaker, and transfer quantitatively to the funnel (A).

About half-fill the funnel with water from tube E. Slowly turn the high-pressure jet (D) on full. Adjust the position of the nozzle under the liquid, in relation to the sieve, until there is little or no disturbance on the surface and the level is, if anything, sinking. Now use the supply from tube E to maintain the level constant and wash down any solid matter adhering to the sides.

NOTE When the best operating conditions have been so attained, the discharge pipe (F) below the sieve is completely filled with water; increasing the length of this column of liquid by adding a length of rubber tubing improves the efficiency of the apparatus.

Take a sample of the issuing water from time to time during the test and, when this is free from suspended matter, reduce the rate of flow from the jet. Wash down any residual material adhering to the sides of the funnel into the lower portion of the apparatus, and then adjust the jet to a rate that keeps the cylindrical portion full of violently agitated water. When the residual matter has been thoroughly washed in this way until the effluent runs clear (usually within 3 min to 4 min), turn off the jet and wash the grit down into the cup. Inspect the remaining sulfur and break up any loose agglomerates by brushing lightly with the camel hair brush (5.2.1.3), subsequently washing them through the sieve. Then wash the remaining grit into the cup.

Unscrew the milled union nut (G), remove the discharge pipe and sieve cup, and wash the contents of the latter with distilled water. Dry the sieve cup and contents at $80\text{ °C} \pm 2\text{ °C}$ for 30 min. Allow it to cool in a desiccator (5.2.1.4) and then weigh it to the nearest 0,1 mg. Repeat this operation until the change in mass is reduced to not more than 1 mg and record the mass of the sieve cup and contents. This mass, less the initial mass of the cup, equals the mass of the sieve residue (m_2).

Repeat the procedure with the other sieve specified in 5.2.1.2, or with another sieve with openings as agreed between the interested parties.

5.2.3 Expression of results

Calculate the sieve residue (W_{rA}), expressed as a percentage by mass, using the following formula:

$$W_{rA} = \frac{m_2}{m_1} \times 100$$

where

m_1 is the mass, in grams, of the test portion;

m_2 is the mass, in grams, of the residue on the sieve.

5.3 Method B

5.3.1 Apparatus

5.3.1.1 Two sieves, of woven metal-wire cloth, in accordance with ISO 565, having openings of nominal width $180\text{ }\mu\text{m}$ and $125\text{ }\mu\text{m}$, respectively.

5.3.1.2 Flat brush, of camel hair or equivalent, 10 mm to 25 mm wide.

5.3.1.3 Desiccator.

5.3.2 Procedure

Dry one of the sieves specified in 5.3.1.1, or a sieve with openings as agreed between the interested parties, at $80\text{ °C} \pm 2\text{ °C}$ for 30 min. Allow it to cool in a desiccator (5.3.1.3) and then weigh it to the nearest 0,1 mg. Repeat this operation until the change in mass is reduced to not more than 1 mg and record the mass of the sieve. From the previously de-agglomerated sample, weigh out, to the nearest 0,1 g, about 10 g (m_3) when using a sieve with openings of less than 100 μm or about 30 g (m_3) when using a sieve with openings of greater than 100 μm , and transfer to a beaker.

From the test portion, make, in a beaker, a suspension using 100 cm^3 or 300 cm^3 (depending on the size of the test portion) of a 20 g/dm^3 solution of alkylaryl sulfonate in water, pressing it lightly with a glass rod to collapse the lumps. After stirring it sufficiently, pour the suspension onto the screen of the sieve. Shake the sieve gently while pouring in water little by little to allow most of the test portion to pass through it. Then put the sieve into an evaporating dish, fill the dish with water up to a level 10 mm to 15 mm above the screen, and sweep the surface of the screen with a brush (5.3.1.2).

Take the sieve out of the dish, drain out the water from the openings in the sieve, and renew the water in the dish. Repeat this operation until no more of the test portion can be seen in the water in the dish. Wash any solid particles adhering to the brush onto the screen with water, then dry the sieve and contents at $80\text{ °C} \pm 2\text{ °C}$ for 30 min. Allow it to cool in a desiccator (5.3.1.3) and then weigh it to the nearest 0,1 mg. Repeat this operation until the change in mass is reduced to not more than 1 mg and record the mass of the sieve and contents. The final mass minus the initial mass of the sieve equals the mass of the sieve residue (m_4).

Repeat the procedure with the other sieve specified in 5.3.1.1, or with another sieve with openings as agreed between the interested parties.

5.3.3 Expression of results

Calculate the sieve residue (W_{rB}), expressed as a percentage by mass, using the following formula:

$$W_{\text{rB}} = \frac{m_4}{m_3} \times 100$$

where

m_3 is the mass, in grams, of the test portion;

m_4 is the mass, in grams, of the residue on the sieve.

5.3.4 Precision

See B.3.3.

6 Determination of oil content of oil-treated sulfur

6.1 Principle

Oil is extracted from the sample by using a solvent, and the solvent is then evaporated off and the mass of residual oil determined. The residual sulfur is weighed and the amount of oil is calculated.

Two procedures are specified:

- a) a procedure using hexane for rhombic sulfur;
- b) a procedure using sulfur-saturated hexane for insoluble sulfur.

6.2 Hexane procedure

6.2.1 Reagents

6.2.1.1 **Hexane**, reagent grade.

6.2.2 Procedure

Weigh, to the nearest 1 mg, about 10 g of the sample (m_g) into a wide-mouthed 250 cm³ conical flask and add, by pipette, exactly 100 cm³ of hexane (6.2.1.1). Stopper the flask and allow it to stand at room temperature for 30 min, swirling the flask every 5 min. Decant 75 cm³ of the solution thus obtained into a 100 cm³ beaker, ensuring that no particles of sulfur are present. Then pipette 50 cm³ of this solution into another 100 cm³ beaker. Evaporate the solvent from this 50 cm³ of solution by placing the beaker in a water bath in a fume cupboard. Remove the beaker from the water bath and allow it to cool to room temperature. Extract the residue with 2 cm³ of hexane, measuring the solvent from a burette and adding it in such a way that the sides of the beaker are washed down. Swirl the beaker gently to disperse the residue with the solvent. Decant the solution into a 50 cm³ beaker, previously weighed to 1 mg (m_{10}).

Repeat the extraction twice, collecting all the washings in the 50 cm³ beaker. Evaporate the solvent in a water bath and then in an oven at 80 °C for about 1 h in a fume cupboard until constant mass. Cool in a desiccator and then weigh immediately to 1 mg (m_{11}).

6.2.3 Expression of results

Calculate the oil content (hexane procedure) (OH), expressed as a percentage by mass, using the following formula:

$$\text{OH} = \frac{2(m_{11} - m_{10})}{m_g} \times 100 - 0,20$$

where

m_g is the mass, in grams, of the test portion;

m_{10} is the mass, in grams, of the beaker;

m_{11} is the mass, in grams, of the beaker plus oil;

0,20 is a correction factor to allow for the solubility of sulfur in hexane.

6.3 Sulfur-saturated hexane procedure

6.3.1 Reagents

6.3.1.1 **Sulfur-saturated hexane**: Add 60 g of reagent-grade rhombic sulfur to 4 dm³ of hexane (6.2.1.1). Mix well and allow to stand for 24 h before use to allow excess sulfur to fall to the bottom of the vessel. Use only the clear supernatant liquid.

6.3.2 Procedure

Weigh, to the nearest 1 mg, 5 g ± 0,01 g of the sample (m_{12}) into a 250 cm³ conical flask and add 25 cm³ of sulfur-saturated hexane (6.3.1.1). Maintain the temperature constant throughout this stage of the procedure.

Shake for 10 min and then filter through a sintered-glass filter crucible of porosity P 40 (see ISO 4793), or equivalent, previously weighed to the nearest 1 mg (m_{13}), and wash the residue with 100 cm³ of sulfur-saturated hexane (6.3.1.1). Wash the residue twice with 25 cm³ of reagent-grade ethanol.

Dry the filter crucible plus residue for about 1 h at 80 °C in an oven in a fume cupboard until constant mass. Then cool in a desiccator and weigh to the nearest 1 mg (m_{14}).

6.3.3 Expression of results

Calculate the oil content (sulfur-saturated hexane procedure) (OSH), expressed as a percentage by mass, using the following formula:

$$\text{OSH} = \frac{(m_{12} + m_{13} - m_{14})}{m_{12}} \times 100$$

where

m_{12} is the mass, in grams, of the test portion;

m_{13} is the mass, in grams, of the filter crucible;

m_{14} is the mass, in grams, of the filter crucible plus residue.

7 Determination of insoluble-sulfur content

7.1 Principle

A test portion is stirred with solvent to dissolve the rhombic sulfur and any oil. The insoluble sulfur is filtered off, dried and weighed.

Two procedures are specified:

- a) a reference procedure using toluene as solvent;
- b) an alternative procedure using carbon disulfide.

Note that the two procedures might give different results.

7.2 Reference procedure using toluene

7.2.1 Reagents

7.2.1.1 Toluene, reagent grade.

7.2.2 Procedure

Weigh, to the nearest 1 mg, approximately 2 g of the sample (m_{15}) in a 400 cm³ beaker. Add 200 cm³ of toluene (7.2.1.1) and a magnetic-stirrer bar. Cover with a watch glass and stir for 30 min. Filter through a sintered-glass filter crucible of porosity P 40 (see ISO 4793), or equivalent, previously weighed to the nearest 1 mg (m_{16}). Remove the toluene by very light suction. Wash three times with 20 cm³ of toluene.

IMPORTANT — The sample shall never be sucked completely dry before the last washing because reversion can occur due to icing of the insoluble sulfur.

After the last washing, completely remove the toluene by suction, and dry the filter crucible in a drying oven in a fume cupboard for 1 h at 80 °C. Cool in a desiccator and weigh to the nearest 1 mg (m_{17}).

7.2.3 Expression of results

7.2.3.1 Calculate the insoluble-sulfur content (IS_{ts1}), expressed as a percentage by mass of the total sample, using the formula

$$IS_{ts1} = \frac{(m_{17} - m_{16})}{m_{15}} \times 100$$

where

m_{15} is the mass, in grams, of the test portion;

m_{16} is the mass, in grams, of the filter crucible;

m_{17} is the mass, in grams, of the filter crucible plus the residue of insoluble sulfur.

7.2.3.2 Calculate the insoluble-sulfur content (IS_{TS1}), expressed as a percentage by mass of the sulfur portion of the sample, using the following formula:

$$IS_{TS1} = \frac{IS_{ts1}}{TS_{ts}} \times 100$$

where

IS_{ts1} is the insoluble-sulfur content in the total sample (see 7.2.3.1);

TS_{ts} is the total sulfur content in the total sample (see 4.4).

7.3 Alternative procedure using carbon disulfide

7.3.1 Reagents

7.3.1.1 Carbon disulfide, reagent grade.

WARNING — Carbon disulfide is a very noxious, toxic and inflammable solvent (boiling point: 46,3 °C, flash point: -30 °C). Special safety precautions shall therefore be taken, including the use of a fume hood and an explosion-proof drying oven.

7.3.2 Procedure

Weigh, to the nearest 1 mg, approximately 5 g of sample (m_{18}) in a 250 cm³ beaker. Add 100 cm³ of carbon disulfide (7.3.1.1) and a magnetic-stirrer bar. Cover with a watch glass and stir for 30 min. Filter through a sintered-glass filter crucible of porosity P 40 (see ISO 4793), or equivalent, previously weighed to the nearest 1 mg (m_{19}). Remove the carbon disulfide by very light suction. Wash three times with 20 cm³ of carbon disulfide.

IMPORTANT — The sample shall never be sucked completely dry before the last washing because reversion can occur due to icing of the insoluble sulfur.

After the last washing, completely remove the carbon disulfide by suction, and dry the filter crucible in a drying oven for 1 h at 80 °C. Cool in a desiccator and weigh to the nearest 1 mg (m_{20}).

7.3.3 Expression of results

7.3.3.1 Calculate the insoluble-sulfur content (IS_{ts2}), expressed as a percentage by mass of the total sample, using the following formula:

$$IS_{ts2} = \frac{(m_{20} - m_{19})}{m_{18}} \times 100$$

where

m_{18} is the mass, in grams, of the test portion;

m_{19} is the mass, in grams, of the filter crucible;

m_{20} is the mass, in grams, of the filter crucible plus the residue of insoluble sulfur.

7.3.3.2 Calculate the insoluble-sulfur content (IS_{TS2}), expressed as a percentage by mass of the sulfur portion of the sample, using the following formula:

$$IS_{TS2} = \frac{IS_{ts2}}{TS_{ts}} \times 100$$

where

IS_{ts2} is the insoluble-sulfur content in the total sample (see 7.3.3.1);

TS_{ts} is the total sulfur content in the total sample (see 4.4).

8 Determination of thermal reversion of insoluble sulfur

8.1 General

Two methods are specified:

- a) method A, in which solubilization of the insoluble sulfur is carried out in mineral oil for 15 min at 105 °C;
- b) method B, in which a test portion of insoluble sulfur is kept in a differential scanning calorimeter for 10 min at 105 °C and the soluble sulfur measured by high-performance liquid chromatography.

Note that the two methods give the same results.

8.2 Method A

8.2.1 Principle

A test portion is heated in white mineral oil at 105 °C for 15 min, followed by rapid cooling. The amount of insoluble sulfur remaining after this treatment is measured. Two procedures are available for this method:

- a) a reference procedure using toluene as solvent when measuring the amount of insoluble sulfur;
- b) an alternative procedure using carbon disulfide.

8.2.2 Apparatus

8.2.2.1 Thermostatic bath, filled with silicone oil, with a magnetic stirrer, capable of being maintained at $105\text{ °C} \pm 0,2\text{ °C}$.

8.2.2.2 Stopwatch.

8.2.2.3 Glass test tube, 20 cm long and 42 mm in diameter, with screw cap or glass stopper.

8.2.2.4 Sintered-glass filter crucible, porosity P 16 (see ISO 4793), or equivalent.

8.2.2.5 Thermometer, accurate to $0,2\text{ °C}$ between 100 °C and 110 °C .

8.2.2.6 Drying oven (explosion-proof type), maintained at 80 °C .

8.2.2.7 Magnetic stirrer.

8.2.2.8 Water bath, containing crushed ice.

8.2.2.9 Suction flask.

8.2.2.10 Desiccator.

8.2.3 Reference procedure

8.2.3.1 Reagents

8.2.3.1.1 Toluene, reagent grade.

WARNING — Toluene is inflammable and toxic.

8.2.3.1.2 White mineral oil, reagent grade.

8.2.3.2 Procedure

Homogenize a representative portion (minimum 10 g) of the sample.

Pour 30 cm^3 of white mineral oil (8.2.3.1.2) into a glass test tube (8.2.2.3) and add a magnetic-stirrer bar.

Put the test tube into the thermostatic bath (8.2.2.1) at $105\text{ °C} \pm 0,2\text{ °C}$ so that it is immersed to a depth of at least 10 cm and centred over the magnetic stirrer (see Figure 2). 15 min after the tube has been placed in the bath, add quickly $1\ 000\text{ mg} \pm 50\text{ mg}$ of sulfur, weighed to the nearest 1 mg (m_{21}). Immediately start the stopwatch (8.2.2.2). After $15\text{ min} \pm 5\text{ s}$, remove the test tube from the thermostatic bath and immediately place it in a bath filled with water and ice (8.2.2.8) and stir for 1 min.

Add 50 cm^3 of toluene (8.2.3.1.1) and place the test tube on a magnetic stirrer (8.2.2.7) for 3 min.

Heat the sintered-glass filter crucible (8.2.2.4) for 1 h at 80 °C and cool it to ambient temperature in a desiccator (8.2.2.10). Weigh the crucible to the nearest 1 mg (m_{22}). Mount the crucible on a suction flask (8.2.2.9) and decant the oil-solvent-sulfur mixture through it while applying very tight suction. Wash the sulfur five times with 20 cm^3 portions of toluene.

IMPORTANT — The sample shall never be sucked completely dry before the last washing because reversion can occur due to icing of the insoluble sulfur.

After the last washing, suck the crucible as dry as possible. Dry the crucible for 1 h in the oven (8.2.2.6) at 80 °C , cool in the desiccator and weigh to 1 mg (m_{23}).

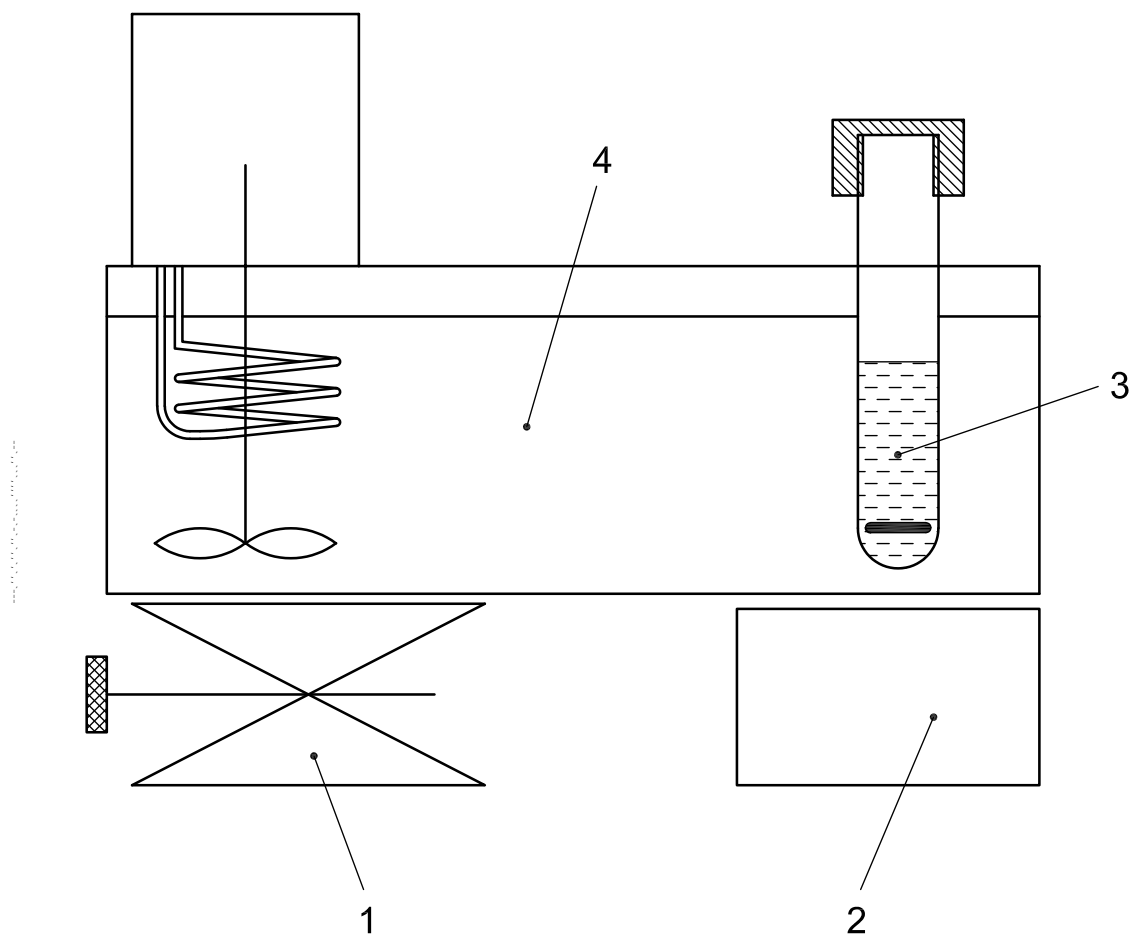

Key

- 1 laboratory jack
- 2 magnetic stirrer
- 3 white mineral oil
- 4 bath containing silicone oil at 105 °C

Figure 2 — Thermostatic bath with magnetic stirrer

8.2.4 Alternative procedure using carbon disulfide

8.2.4.1 Reagents

8.2.4.1.1 Carbon disulfide, reagent grade.

WARNING — Carbon disulfide is a very noxious, toxic and inflammable solvent (boiling point: 46,3 °C, flash point: -30 °C). Special safety precautions shall therefore be taken, including the use of a fume hood and an explosion-proof drying oven.

8.2.4.2 Procedure

Homogenize a representative portion (minimum 10 g) of the sample.

Pour 30 cm³ of white mineral oil (8.2.3.1.2) into a glass test tube (8.2.2.3) and add a magnetic-stirrer bar.

Put the test tube into the thermostatic bath (8.2.2.1) at $105\text{ °C} \pm 0,2\text{ °C}$ so that it is immersed to a depth of at least 10 cm and centred over the magnetic stirrer (see Figure 2). 15 min after the tube has been placed in the bath, add quickly $1\ 000\text{ mg} \pm 50\text{ mg}$ of sulfur, weighed to the nearest 1 mg (m_{21}). Immediately start the stopwatch (8.2.2.2). After $15\text{ min} \pm 5\text{ s}$, remove the test tube from the oil bath and immediately place it in a bath filled with water and ice (8.2.2.8) and stir for 1 min.

Add 50 cm^3 of carbon disulfide (8.2.4.1.1) and place the test tube on a magnetic stirrer (8.2.2.7) for 3 min.

Heat the sintered-glass filter crucible (8.2.2.4) for 1 h at 80 °C and cool it to ambient temperature in a desiccator (8.2.2.10). Weigh the crucible to the nearest 1 mg (m_{22}). Mount the crucible on a suction flask (8.2.2.9) and decant the oil-solvent-sulfur mixture through it while applying very tight suction. Wash the sulfur five times with 20 cm^3 portions of carbon disulfide.

IMPORTANT — The sample shall never be sucked completely dry before the last washing because reversion can occur due to icing of the insoluble sulfur.

After the last washing, suck the crucible as dry as possible. Dry the crucible for 1 h in the oven (8.2.2.6) at 80 °C , cool in the desiccator and weigh to 1 mg (m_{23}).

8.2.5 Expression of results

Calculate the percentage thermal reversion (R_A) of the insoluble sulfur using the following formula:

$$R_A = \left[\text{IS}_{\text{ts1}} - \frac{(m_{23} - m_{22}) \times 100}{m_{21}} \right] \times \frac{100}{\text{IS}_{\text{ts1}}}$$

where

m_{21} is the mass, in grams, of the test portion;

m_{22} is the mass, in grams, of the filter crucible;

m_{23} is the mass, in grams, of the filter crucible plus the residue of insoluble sulfur;

IS_{ts1} is the initial insoluble-sulfur content, expressed as a percentage by mass of the total sample, calculated as in 7.2.3.1.

8.3 Method B

8.3.1 Principle

A test portion is heated at 105 °C in a differential scanning calorimeter for 10 min. Then the amount of soluble sulfur converted from insoluble sulfur is measured by high-performance liquid chromatography (HPLC).

8.3.2 Apparatus

8.3.2.1 Differential scanning calorimeter (DSC), calibrated in accordance with the manufacturer's specification and using indium as the temperature standard (onset).

8.3.2.2 High-performance liquid chromatograph, equipped with two pumps for programmed elution, variable-wavelength UV detector, and recorder with integrator.

8.3.2.3 HPLC column, reverse-phase type.

8.3.2.4 Volumetric flasks, $1 \times 100\text{ cm}^3$ and $7 \times 20\text{ cm}^3$ capacity.

8.3.3 Reagents

8.3.3.1 **Methylene chloride**, reagent grade.

8.3.3.2 **Soluble (rhombic) sulfur**, reagent grade.

8.3.3.3 **Methanol**, HPLC grade.

8.3.3.4 **Water**, HPLC grade.

8.3.4 Chromatographic conditions¹⁾

- Pump A: 100 % methanol.
- Pump B: 60 % methanol + 40 % water.
- Flow: 80 % pump A, 20 % pump B.
- Total flow: 2 cm³/min.
- Wavelength: 275 nm.
- Column oven: 40 °C.
- Injection volume: preferably 50 mm³ (20 mm³ might be acceptable).

Note, however, that it is essential to use the same injection volume both in the preparation of the calibration curve (see 8.3.5) and in the actual determination (see 8.3.7 and 8.3.8).

8.3.5 Preparation of calibration curve (soluble sulfur)

Weigh 30 mg of soluble sulfur (8.3.3.2) into a 100 cm³ volumetric flask (see 8.3.2.4).

Add 50 cm³ of methylene chloride (8.3.3.1). Shake until the soluble sulfur dissolves. Fill to the mark with methylene chloride.

Transfer 1 cm³, 2 cm³, 3 cm³, 5 cm³, 7 cm³, 10 cm³ and 15 cm³ aliquots of this solution into 20 cm³ volumetric flasks (see 8.3.2.4). Fill each to the mark with methylene chloride.

Inject 50 mm³ (or 20 mm³) of each solution into the chromatograph (8.3.2.2).

Calculate the areas of the soluble sulfur peaks.

Plot the total amount of soluble sulfur in each flask versus the corresponding areas. Calculate the best-fit line either by computer or graphically.

NOTE A calibration curve is not always necessary. Within a narrow range, two standard solutions can be assumed to define a straight-line relationship.

8.3.6 DSC programme

Starting temperature: 40 °C.

Final temperature: 105 °C.

Heating rate: 50 °C/min.

1) Other conditions may be used as long as the soluble sulfur peak is well resolved.

Time at 105 °C: 10 min.

Cooling rate: 50 °C/min.

If the calorimeter does not have a cooling system capable of cooling the test portion at 50 °C/min, open the sample compartment of the calorimeter immediately at the end of the heating period and transfer the contents of the pan as rapidly as possible into the 20 cm³ volumetric flask containing 10 cm³ of solvent.

8.3.7 Procedure for initial soluble sulfur

Weigh 10 mg of the sample (m_{24}) into a 20 cm³ volumetric flask.

Add to the flask 10 cm³ of methylene chloride. Shake the flask for 5 min. Fill to the mark with methylene chloride. Allow to stand for 2 h.

Inject 50 mm³ (or 20 mm³) of the solution into the HPLC apparatus. Use the same injection volume as was used in the preparation of the calibration curve.

Calculate the area of the soluble-sulfur peak.

From the calibration curve, determine the initial amount of soluble sulfur in the flask (m_{25}).

Calculate the initial soluble-sulfur content (SS₀) of the sample, expressed as a percentage by mass, using the following formula:

$$SS_0 = \frac{m_{25}}{m_{24}} \times 100$$

where

m_{24} is the mass, in grams, of the test portion;

m_{25} is the initial mass, in grams, of soluble sulfur found.

8.3.8 Procedure for soluble sulfur after 10-min exposure time

Weigh 10 mg of the sample (m_{26}) into a DSC pan.

Without covering it, introduce it into the sample compartment of the calorimeter.

Start the DSC programme (see 8.3.6).

At the end, transfer the contents of the pan into a 20 cm³ volumetric flask containing 10 cm³ of methylene chloride. Shake the flask for 5 min. Fill to the mark with methylene chloride.

Allow to stand for 2 h.

Inject 50 mm³ (or 20 mm³) of the solution into the HPLC apparatus. Use the same injection volume as was used in the preparation of the calibration curve.

Calculate the area of the soluble-sulfur peak.

From the calibration curve, determine the amount of soluble sulfur in the flask after the 10-min exposure time (m_{27}).

Calculate the soluble-sulfur content of the sample after the 10-min exposure time (SS_{10}), expressed as a percentage by mass, using the following formula:

$$SS_{10} = \frac{m_{27}}{m_{26}} \times 100$$

where

m_{26} is the mass, in grams, of the test portion;

m_{27} is the mass, in grams, of soluble sulfur after 10 min.

8.3.9 Expression of results

Calculate the percentage thermal reversion of the insoluble sulfur (R_B) using the following formula:

$$R_B = \frac{(SS_{10} - SS_0)}{(100 - SS_0 - OSH)} \times 100$$

where

SS_0 is the initial soluble-sulfur content;

SS_{10} is the soluble-sulfur content after 10-min exposure time;

OSH is the oil content of the sample, expressed as a percentage by mass (see Clause 6).

8.4 Precision

See B.3.1.

9 Determination of loss in mass at 80 °C

9.1 Principle

A test portion is heated in an oven at 80 °C and the resulting loss in mass is determined by weighing.

Two methods are specified:

- a) method A: a test portion is dried in an oven for a fixed drying period (9.3.1);
- b) method B: a test portion is dried in an oven to constant mass (9.3.2).

9.2 Apparatus

Ordinary laboratory apparatus and the following.

9.2.1 Weighing bottle, about 60 mm diameter and about 75 mm high, equipped with a lid.

9.2.2 Electric oven, capable of being maintained at 80 °C ± 2 °C.

9.2.3 Desiccator.

9.3 Procedure

9.3.1 Method A

Dry the weighing bottle (9.2.1) and its lid in the oven (9.2.2), set at $80\text{ °C} \pm 2\text{ °C}$, for 2 h. Cool it in a desiccator (9.2.3) and weigh to the nearest 1 mg. Weigh, to the nearest 1 mg, a 50 g (m_{28}) test portion into the weighing bottle.

Place the weighing bottle (9.2.1) with the test portion, the weighing-bottle lid and a watch glass in the oven (9.2.2), set at $80\text{ °C} \pm 2\text{ °C}$, for 3 h.

The diameter of the watch glass shall be slightly larger than that of the weighing bottle.

After drying, place the watch glass on the weighing bottle and put all in a desiccator. After cooling to room temperature, close the weighing bottle with its lid and reweigh to the nearest 1 mg.

9.3.2 Method B

Dry the weighing bottle (9.2.1) and its lid in the oven (9.2.2), set at $80\text{ °C} \pm 2\text{ °C}$, for 2 h. Cool it in a desiccator (9.2.3) and weigh to the nearest 1 mg. Weigh, to the nearest 1 mg, a 50 g (m_{28}) test portion into the weighing bottle.

Dry a test portion to constant mass within a total drying period not exceeding 15 h, as follows:

Place the weighing bottle (9.2.1) with the test portion, the weighing-bottle lid and a watch glass in the oven (9.2.2), set at $80\text{ °C} \pm 2\text{ °C}$, for 3 h.

After drying, place the watch glass on the weighing bottle and put all in a desiccator. After cooling to room temperature, close the weighing bottle with its lid and reweigh to the nearest 1 mg.

Repeat the above procedure until the mass becomes constant, i.e. until two consecutive weighings do not differ by more than 5 mg.

If constant mass is not achieved after a total period of 15 h drying by this second procedure, record the result of the final weighing.

9.4 Expression of results

The loss in mass (L), expressed as a percentage by mass, is given by the following formula:

$$L = \frac{m_{29}}{m_{28}} \times 100$$

where

m_{28} is the mass, in grams, of the test portion before heating;

m_{29} is the loss in mass, in grams, after heating.

9.5 Precision

See B.3.4.

10 Determination of ash at 850 °C to 900 °C

10.1 Principle

A test portion of dry sulfur is treated by slow combustion in air. It is heated in a furnace at 850 °C to 900 °C, then weighed.

10.2 Apparatus

Ordinary laboratory apparatus and the following:

10.2.1 Porcelain dish, tall-form.

10.2.2 Hotplate, or Bunsen burner and refractory triangle.

10.2.3 Electric furnace, capable of being maintained at 850 °C to 900 °C.

10.2.4 Fume hood.

10.3 Procedure

10.3.1 Heat the dish in the furnace maintained at 850 °C to 900 °C for more than 10 min. Allow to cool in a desiccator and weigh to the nearest 1 mg.

10.3.2 Weigh, to the nearest 1 mg, about 10 g (m_{30}) of the sample into the dish (10.2.1).

10.3.3 Place the dish (10.2.1) containing the test portion on the hotplate (10.2.2) at approximately 200 °C (or on a refractory triangle over a Bunsen burner) and gently melt the sulfur. When melting is complete, set fire to the sulfur with a small gas flame (e.g. from a Bunsen burner). Adjust the heating rate so that the sulfur burns slowly (temperature just sufficient to maintain combustion) and completely (combustion period: about 1 h).

10.3.4 Heat the dish and the residue from the combustion of the sulfur in the furnace (10.2.3) maintained at 850 °C to 900 °C.

10.3.5 Allow to cool in a desiccator and weigh to the nearest 1 mg.

10.3.6 Replace the dish in the furnace and repeat the previous operations of 10.3.4 and 10.3.5 until two successive weighings do not differ by more than 5 mg. Record the last weighing (m_{31}).

10.4 Expression of results

The ash (A), expressed as a percentage by mass of the dry product, is given by the following formula:

$$A = \frac{m_{31}}{m_{30}} \times 100$$

where

m_{30} is the mass, in grams, of the test portion;

m_{31} is the mass, in grams, of the residue after heating.

10.5 Precision

See B.3.5.

11 Determination of acidity

Conduct the test in accordance with ISO 3704.

12 Determination of arsenic content

Conduct the test in accordance with ISO 3705 and ISO 2590.

13 Test report

The test report shall include the following particulars:

- a) a reference to this International Standard and the procedure used;
- b) all details necessary for the identification of the sample;
- c) the results of the tests, including;
 - 1) total sulfur content,
 - 2) sieve residue,
 - 3) oil content of oil-treated sulfur,
 - 4) insoluble-sulfur content,
 - 5) thermal reversion of insoluble sulfur,
 - 6) loss in mass at 80 °C,
 - 7) ash at 850 °C to 900 °C,
 - 8) acidity (as H₂SO₄),
 - 9) arsenic (if necessary);
- d) the date of testing;
- e) details of any deviation from the standard test procedure.

© ISO 2011. All rights reserved.

Annex A (informative)

Typical values of the properties of sulfur used as a rubber compounding ingredient

A.1 Soluble (rhombic) sulfur

Table A.1 shows typical values for soluble (rhombic) sulfur used as a compounding ingredient for dry rubber.

See Clause 3 for the test methods used.

Table A.1 — Typical values for soluble (rhombic) sulfur

Property	Grade W	Grade X	Grade Y	Grade Z
Nominal oil content [% (by mass)]	Nil	1	2,5	5
Acidity [as H ₂ SO ₄ , % (by mass)], max.	0,05	0,05	0,05	0,05
Loss in mass [% (by mass)], max.	0,30	0,45	0,50	0,55
Ash [% (by mass)], max. ^a	0,40	0,40	0,40	0,40
Fineness (sieve residue) [% (by mass)]				
125 µm, max.	0,2	0,2	0,2	0,2
180 µm, max.	0,02	0,02	0,02	0,02
Oil content [% (by mass)]	Nil	1 ± 0,25	2,5 ± 0,5	5 ± 0,75
Arsenic (mg/kg), max.	5	5	5	5
^a Sulfur coated with inorganic pigments, such as magnesium carbonate or silica, might give different values upon ashing than those indicated.				

A.2 Insoluble (amorphous) sulfur

Table A.2 shows typical values for insoluble (amorphous) sulfur used as a compounding ingredient for dry rubber.

See Clause 3 for the test methods used.

Table A.2 — Typical values for insoluble (amorphous) sulfur

Property	Grade F	Grade G	Grade L	Grade M	Grade N	Grade P
Nominal insoluble sulfur [% (by mass)]	75	63	90	70	50	40
Acidity [as H ₂ SO ₄ , % (by mass)], max.	0,40	0,01	0,50	0,40	0,35	0,25
Loss in mass [% (by mass)], max.	0,50	0,20	0,50	0,55	0,60	0,65
Ash [% (by mass)], max. ^a	0,30	0,01	0,30	0,30	0,30	0,30
Fineness (sieve residue) [% (by mass)]						
125 µm, max.	NA ^b	NA ^b	0,2	0,2	0,2	0,2
180 µm, max.	0,1	0,2	0,02	0,02	0,02	0,02
Total sulfur [% (by mass)]	80 ± 1	99 (min.)	99 (min.)	80 ± 1	65 ± 1	50 ± 1
Oil content [% (by mass)]	20 ± 1	Nil	Nil	20 ± 1	35 ± 1	50 ± 1
Thermal reversion (on total sulfur), max.	25	50	50	50	50	50
Arsenic (mg/kg), max.	5	5	5	5	5	5
^a Sulfur coated with inorganic pigments, such as magnesium carbonate or silica, might give different values upon ashing than those indicated.						
^b NA = test not applicable.						

Annex B **(informative)**

Precision

B.1 General

The precision calculations to express repeatability and reproducibility were performed in accordance with ISO/TR 9272.

B.2 Precision details

B.2.1 Determination of thermal reversion of insoluble sulfur

A type 1 interlaboratory test programme (ITP) was organized in 1992. The time period for repeatability was one day to seven days.

Three sulfur samples (A, B and C), with different thermal reversions, were sent to the participating laboratories where they were tested using both of the methods.

B.2.2 Determination of total sulfur content, sieve residue, loss in mass and ash

A type 1 ITP was organized in 2002. The time period for repeatability was seven days.

For determining the total sulfur content, loss in mass and ash, two different sulfur samples (soluble sulfur and insoluble sulfur with 20 % oil-treated) were sent to the participating laboratories. For determining the sieve residue, two different sulfur samples (soluble sulfur with 5 % oil-treated and insoluble sulfur with 20 % oil-treated) were sent to the participating laboratories.

B.3 Precision results

B.3.1 Determination of thermal reversion of insoluble sulfur

The precision results for methods A and B are given in Tables B.1 and B.2, respectively.

Table B.1 — Precision data for thermal reversion using method A

Sample	Mean level %	Within-laboratory			Between laboratories		
		s_r	r	(r)	s_R	R	(R)
A	66,75	1,03	2,86	4,28	2,28	6,32	9,47
B	66,75	0,32	0,89	1,33	2,14	5,93	8,88
C	67,49	0,26	0,72	1,07	3,36	9,31	13,79
Pooled or average values ($p = 8, q = 3, n = 2$)	67,00	0,64	1,77	2,64	2,65	7,35	10,97
<p>p is the number of laboratories. q is the number of materials (samples). n is the number of (within-laboratory) replicates.</p> <p>s_r is the within-laboratory standard deviation. s_R is the between-laboratory standard deviation. r is the repeatability, in measurement units. (r) is the repeatability, in percent^a. R is the reproducibility, in measurement units. (R) is the reproducibility, in percent^a.</p> <p>^a These values represent percent relative, i.e. percent of a percent.</p>							

Table B.2 — Precision data for thermal reversion using method B

Sample	Average %	Within-laboratory			Between laboratories		
		s_r	r	(r)	s_R	R	(R)
A	14,16	1,81	5,02	35,45	2,24	6,21	43,86
B	14,40	1,19	3,30	22,92	2,28	6,32	43,89
C	9,90	1,34	3,71	37,47	2,59	7,18	72,53
Pooled or average values ($p = 7, q = 3, n = 2$)	12,82	1,47	4,07	31,75	2,38	6,60	51,48
NOTE Symbols are as given in Table B.1.							

B.3.2 Determination of total sulfur content

The precision results are given in Table B.3.

Table B.3 — Precision data for total sulfur content

Sample	Mean level %	Within-laboratory			Between laboratories		
		s_r	r	(r)	s_R	R	(R)
Soluble sulfur	99,94	0,14	0,38	0,38	0,27	0,77	0,77
Insoluble sulfur, 20 % oil-treated	79,92	0,17	0,49	0,61	0,35	1,00	1,25
$p = 3, q = 2, n = 2.$							
NOTE Symbols are as given in Table B.1.							

B.3.3 Determination of sieve residue using method B

The precision results for method B are given in Table B.4.

Table B.4 — Precision data for sieve residue using method B

Sample		Mean level %	Within-laboratory			Between laboratories		
			s_r	r	(r)	s_R	R	(R)
180 μ m	Soluble sulfur, 5 % oil-treated	0,014	0,006	0,017	120,3	0,014	0,040	292,0
	Insoluble sulfur, 20 % oil-treated	0,014	0,002	0,005	34,7	0,004	0,011	77,8
125 μ m	Soluble sulfur, 5 % oil-treated	0,019	0,006	0,016	84,2	0,028	0,079	415,8
	Insoluble sulfur, 20 % oil-treated	0,029	0,006	0,018	62,4	0,009	0,024	83,0

$p = 4, q = 2, n = 2.$

NOTE Symbols are as given in Table B.1.

B.3.4 Determination of loss in mass at 80 °C using method A

The precision results for method A are given in Table B.5.

Table B.5 — Precision data for loss in mass at 80 °C using method A

Sample	Mean level %	Within-laboratory			Between laboratories		
		s_r	r	(r)	s_R	R	(R)
Soluble sulfur	0,014	0,002	0,007	46,4	0,004	0,011	80,7
Insoluble sulfur, 20 % oil-treated	0,113	0,015	0,043	38,1	0,015	0,043	38,1

$p = 4, q = 2, n = 2.$

NOTE Symbols are as given in Table B.1.

B.3.5 Determination of ash at 850 °C to 900 °C

The precision results are given in Table B.6.

Table B.6 — Precision data for ash at 850 °C to 900 °C

Sample	Mean level %	Within-laboratory			Between laboratories		
		s_r	r	(r)	s_R	R	(R)
Soluble sulfur	0,006	0,001	0,002	34,9	0,001	0,003	39,7
Insoluble sulfur, 20 % oil-treated	0,007	0,001	0,001	19,1	0,002	0,004	64,7

$p = 4, q = 2, n = 2.$

NOTE Symbols are as given in Table B.1.

Bibliography

- [1] ISO/TR 9272, *Rubber and rubber products — Determination of precision for test method standards*

ICS 83.040.20

Price based on 25 pages