

---

---

**Aerospace — Nuts, hexagonal, plain, normal height, normal across flats, with MJ threads, classifications: 600 MPa (at ambient temperature)/120 °C, 600 MPa (at ambient temperature)/235 °C, 900 MPa (at ambient temperature)/425 °C, 1 100 MPa (at ambient temperature)/235 °C, 1 100 MPa (at ambient temperature)/315 °C, 1 100 MPa (at ambient temperature)/650 °C, 1 210 MPa (at ambient temperature)/730 °C, 1 250 MPa (at ambient temperature)/235 °C and 1 550 MPa (at ambient temperature)/600 °C — Dimensions**

*Aéronautique et espace — Écrous hexagonaux ordinaires, hauteur normale, surplats normaux, à filetages MJ, classifications: 600 MPa (à température ambiante)/120 °C, 600 MPa (à température ambiante)/235 °C, 900 MPa (à température ambiante)/425 °C, 1 100 MPa (à température ambiante)/235 °C, 1 100 MPa (à température ambiante)/315 °C, 1 100 MPa (à température ambiante)/650 °C, 1 210 MPa (à température ambiante)/730 °C, 1 250 MPa (à température ambiante)/235 °C et 1 550 MPa (à température ambiante)/600 °C — Dimensions*



**PDF disclaimer**

This PDF file may contain embedded typefaces. In accordance with Adobe's licensing policy, this file may be printed or viewed but shall not be edited unless the typefaces which are embedded are licensed to and installed on the computer performing the editing. In downloading this file, parties accept therein the responsibility of not infringing Adobe's licensing policy. The ISO Central Secretariat accepts no liability in this area.

Adobe is a trademark of Adobe Systems Incorporated.

Details of the software products used to create this PDF file can be found in the General Info relative to the file; the PDF-creation parameters were optimized for printing. Every care has been taken to ensure that the file is suitable for use by ISO member bodies. In the unlikely event that a problem relating to it is found, please inform the Central Secretariat at the address given below.



**COPYRIGHT PROTECTED DOCUMENT**

© ISO 2008

All rights reserved. Unless otherwise specified, no part of this publication may be reproduced or utilized in any form or by any means, electronic or mechanical, including photocopying and microfilm, without permission in writing from either ISO at the address below or ISO's member body in the country of the requester.

ISO copyright office  
Case postale 56 • CH-1211 Geneva 20  
Tel. + 41 22 749 01 11  
Fax + 41 22 749 09 47  
E-mail [copyright@iso.org](mailto:copyright@iso.org)  
Web [www.iso.org](http://www.iso.org)

Published in Switzerland

## Foreword

ISO (the International Organization for Standardization) is a worldwide federation of national standards bodies (ISO member bodies). The work of preparing International Standards is normally carried out through ISO technical committees. Each member body interested in a subject for which a technical committee has been established has the right to be represented on that committee. International organizations, governmental and non-governmental, in liaison with ISO, also take part in the work. ISO collaborates closely with the International Electrotechnical Commission (IEC) on all matters of electrotechnical standardization.

International Standards are drafted in accordance with the rules given in the ISO/IEC Directives, Part 2.

The main task of technical committees is to prepare International Standards. Draft International Standards adopted by the technical committees are circulated to the member bodies for voting. Publication as an International Standard requires approval by at least 75 % of the member bodies casting a vote.

Attention is drawn to the possibility that some of the elements of this document may be the subject of patent rights. ISO shall not be held responsible for identifying any or all such patent rights.

ISO 8279 was prepared by Technical Committee ISO/TC 20, *Aircraft and space vehicles*, Subcommittee SC 4, *Aerospace fastener systems*.

This third edition cancels and replaces the second edition (ISO 8279:1997), which has been technically revised.

## Introduction

The dimensions specified in this International Standard have been determined to satisfy the requirements of the procurement specification ISO 9139.

# **Aerospace — Nuts, hexagonal, plain, normal height, normal across flats, with MJ threads, classifications: 600 MPa (at ambient temperature)/120 °C, 600 MPa (at ambient temperature)/235 °C, 900 MPa (at ambient temperature)/425 °C, 1 100 MPa (at ambient temperature)/235 °C, 1 100 MPa (at ambient temperature)/315 °C, 1 100 MPa (at ambient temperature)/650 °C, 1 210 MPa (at ambient temperature)/730 °C, 1 250 MPa (at ambient temperature)/235 °C and 1 550 MPa (at ambient temperature)/600 °C — Dimensions**

## **1 Scope**

This International Standard specifies the dimensions of plain, hexagonal nuts, of normal height, normal across flats, with MJ threads, of classifications: 600 MPa<sup>1)</sup>/120 °C<sup>2)</sup>, 600 MPa<sup>1)</sup>/235 °C<sup>2)</sup>, 900 MPa<sup>1)</sup>/425 °C<sup>2)</sup>, 1 100 MPa<sup>1)</sup>/235 °C<sup>2)</sup>, 1 100 MPa<sup>1)</sup>/315 °C<sup>2)</sup>, 1 100 MPa<sup>1)</sup>/650 °C<sup>2)</sup>, 1 210 MPa<sup>1)</sup>/730 °C<sup>2)</sup>, 1 250 MPa<sup>1)</sup>/235 °C<sup>2)</sup> and 1 550 MPa<sup>1)</sup>/600 °C<sup>2)</sup>.

Nuts provided with holes are intended to be used with lockwire in conformity with ISO 245.

This International Standard is only applicable for the compilation of aerospace product standards.

## **2 Normative references**

The following referenced documents are indispensable for the application of this document. For dated references, only the edition cited applies. For undated references, the latest edition of the referenced document (including any amendments) applies.

ISO 245, *Aerospace — Lockwire — Diameters*

ISO 5855-2, *Aerospace — MJ threads — Part 2: Limit dimensions for bolts and nuts*

ISO 8788, *Aerospace — Nuts, metric — Tolerances of form and position*

- 1) Corresponds to the minimum tensile stress that the nut is able to withstand at ambient temperature, without breaking or cracking, when tested with a bolt of a higher strength class.
- 2) Maximum temperature that the nut is able to withstand, without permanent alteration to its original characteristics, after ambient temperature has been restored. The maximum temperature is conditioned by the material or by the surface treatment.

### 3 Configuration and dimensions

See Figure 1 and Table 1.

Dimensions and tolerances are expressed in millimetres.

They apply after any surface coating(s), but before the application of any lubricant.

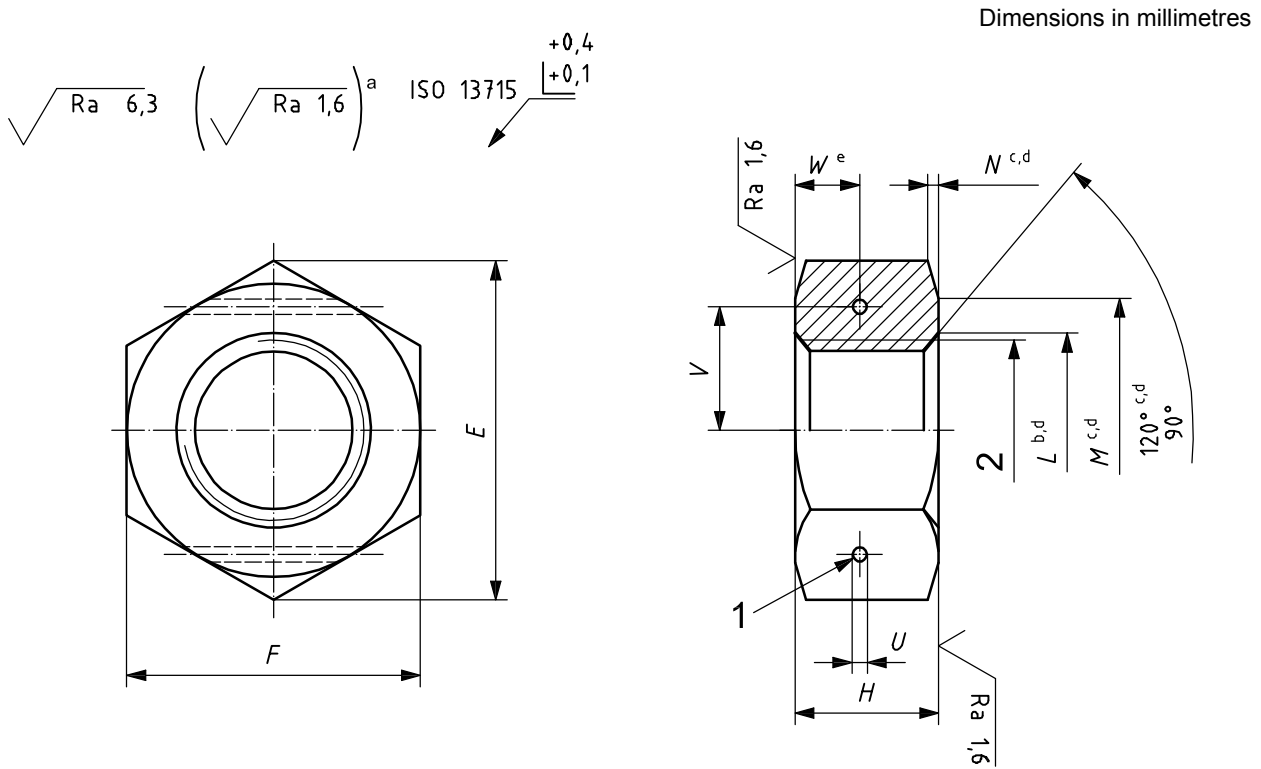

Tolerances of form and position shall conform to those specified in ISO 8788. Details of form not stated are left to the manufacturer's discretion.

#### Key

- 1 two holes diameter  $U$ , optional
- 2 thread

- a These values, in micrometres, apply before any surface coating(s) is(are) applied. The values do not apply to threads whose surface texture will be as achieved by the usual manufacturing methods.
- b All forms of entry (chamfer or radius) permissible within these limiting dimensions.
- c Form of contour, within limiting dimensions, is left to the manufacturer's discretion. Diameter  $M$  may be tangential to, but shall not intrude on, the flats.
- d To both faces.
- e From one face.

Figure 1

Table 1

Dia- meter code	Thread <sup>a</sup>	<i>L</i>		<i>M</i>	<i>U</i>	<i>E</i>	<i>F</i>		<i>H</i>	<i>N</i>		<i>V</i>	<i>W</i>	Lockwire diameter <sup>b</sup>
		nom.	tol.	min.	H13	min.	nom.	tol.	h14	nom.	tol.	± 0,2	min.	
020	MJ2 × 0,4-4H6H	2,2	+0,6 0	3,4	—	4,2	4	h12	1,6	0,4	0 -2	—	—	—
025	MJ2,5 × 0,45-4H6H	2,7		4,4		5,3	5		2					
030	MJ3 × 0,5-4H6H	3,2		5,4		6,5	6		2,4					
040	MJ4 × 0,7-4H6H	4,2		6,4		7,6	7		3,2					
050	MJ5 × 0,8-4H6H	5,2		7,4		8,7	8		4					
060	MJ6 × 1-4H5H	6,3	+0,8 0	9,3	1	10,9	10	h13	4,8	0,5	0 -3	3,9	2	0,8
070	MJ7 × 1-4H5H	7,3		10,2		12	11		5,6			4,4	2,4	
080	MJ8 × 1-4H5H	8,3		12,2		14,3	13		6,4			5	2,8	
100	MJ10 × 1,25-4H5H	10,3		16	18,9	17	8		6,9	3,6		1,25		
120	MJ12 × 1,25-4H5H	12,3		18	21,1	19	9,6		8	4,4				
140	MJ14 × 1,5-4H5H	14,4		21	24,5	22	11,2		9,6	5,1				
160	MJ16 × 1,5-4H5H	16,4		23	26,8	24	12,8		10,7	5,9				
180	MJ18 × 1,5-4H5H	18,4		26	30,2	27	14,4		12	6,7				
200	MJ20 × 1,5-4H5H	20,4		29	33,6	30	16		13,4	7,5				
220	MJ22 × 1,5-4H5H	22,4		30,9	35,8	32	17,6		14,4	8,3				
240	MJ24 × 2-4H5H	24,5	34,9	40,4	36	19,2	16,1	9,1						

<sup>a</sup> In accordance with ISO 5855-2.

<sup>b</sup> For information, in conformity with ISO 245.

## Bibliography

- [1] ISO 9139, *Aerospace — Nuts, plain or slotted (castellated) — Procurement specification*
- [2] ISO 13715, *Technical drawings — Edges of undefined shape — Vocabulary and indications*



\*\*\*\*\*

---

---

**ICS 49.030.30**

Price based on 4 pages