**Aircraft — Tow bar attachment fittings
interface requirements —**

**Part 2:
Regional aircraft**

Aéronefs — Exigences d'interface des ferrures d'attache de barre de tractage —

Partie 2: Aéronefs régionaux



PDF disclaimer

This PDF file may contain embedded typefaces. In accordance with Adobe's licensing policy, this file may be printed or viewed but shall not be edited unless the typefaces which are embedded are licensed to and installed on the computer performing the editing. In downloading this file, parties accept therein the responsibility of not infringing Adobe's licensing policy. The ISO Central Secretariat accepts no liability in this area.

Adobe is a trademark of Adobe Systems Incorporated.

Details of the software products used to create this PDF file can be found in the General Info relative to the file; the PDF-creation parameters were optimized for printing. Every care has been taken to ensure that the file is suitable for use by ISO member bodies. In the unlikely event that a problem relating to it is found, please inform the Central Secretariat at the address given below.

© ISO 2005

All rights reserved. Unless otherwise specified, no part of this publication may be reproduced or utilized in any form or by any means, electronic or mechanical, including photocopying and microfilm, without permission in writing from either ISO at the address below or ISO's member body in the country of the requester.

ISO copyright office
Case postale 56 • CH-1211 Geneva 20
Tel. + 41 22 749 01 11
Fax + 41 22 749 09 47
E-mail copyright@iso.org
Web www.iso.org

Published in Switzerland

Foreword

ISO (the International Organization for Standardization) is a worldwide federation of national standards bodies (ISO member bodies). The work of preparing International Standards is normally carried out through ISO technical committees. Each member body interested in a subject for which a technical committee has been established has the right to be represented on that committee. International organizations, governmental and non-governmental, in liaison with ISO, also take part in the work. ISO collaborates closely with the International Electrotechnical Commission (IEC) on all matters of electrotechnical standardization.

International Standards are drafted in accordance with the rules given in the ISO/IEC Directives, Part 2.

The main task of technical committees is to prepare International Standards. Draft International Standards adopted by the technical committees are circulated to the member bodies for voting. Publication as an International Standard requires approval by at least 75 % of the member bodies casting a vote.

Attention is drawn to the possibility that some of the elements of this document may be the subject of patent rights. ISO shall not be held responsible for identifying any or all such patent rights.

ISO 8267-2 was prepared by Technical Committee ISO/TC 20, *Aircraft and space vehicles*, Subcommittee SC 9, *Air cargo and ground equipment*.

This first edition of ISO 8267-2, together with ISO 8267-1, cancels and replaces ISO 8267:1997, which has been technically revised.

ISO 8267 consists of the following parts, under the general title *Aircraft — Tow bar attachment fittings interface requirements*:

- *Part 1 : Main line aircraft*
- *Part 2: Regional aircraft*

Introduction

The aim of this part of ISO 8267 is to standardize regional aircraft tow bar attachment fittings according to aircraft mass category (which determines tow bar forces), so that one tow bar can be used for all aircraft within that mass category.

Throughout this part of ISO 8267, the minimum essential criteria are identified by the use of the key-word 'shall'. Recommended criteria are identified by the use of the key-word 'should' and, while not mandatory, are considered to be of primary importance in providing safe aircraft towing arrangements. Deviation from recommended criteria should only occur after careful consideration, extensive testing, and thorough service evaluation have shown alternative methods to be satisfactory.

Aircraft — Tow bar attachment fittings interface requirements —

Part 2: Regional aircraft

1 Scope

This part of ISO 8267 specifies the interface requirements for tow bar attachment fittings on the nose gear (when towing operations are performed from the nose gear) of conventional tricycle type landing gears of commercial civil transport aircraft.

Its purpose is to achieve tow bar attachment fittings interface standardization by aircraft mass category (which determines tow bar forces) in order to ensure that a single type of tow bar with a standard connection can be used for all aircraft types within or near that mass category, so as to assist operators and airport handling companies in reducing the number of different tow bar types used.

This part of ISO 8267 is applicable to all new models of regional aircraft within the specified maximum ramp mass range which enter service or are designed after its date of publication.

It does not apply to previously in service regional aircraft models, which present a considerable variety of tow bar attachment fittings. However, a simple retrofit modification is described that may make certain in-service fittings compatible with a tow bar head in conformity with this part of ISO 8267, where deemed appropriate in order to facilitate operation of such aircraft types at airports.

This part of ISO 8267 is applicable to regional commercial transport aircraft airworthiness certified under FAR/JAR Parts 25 with a maximum ramp mass of $\leq 50\,000$ kg (110 000 lb). It does not apply to

- aircraft airworthiness certified under FAR/JAR Parts 23 as commuter category aeroplanes;
- aircraft airworthiness certified under FAR/JAR Parts 25 but with a maximum ramp mass of $> 50\,000$ kg (110 000 lb), which are covered by ISO 8267-1.

Where a family of existing or contemplated aircraft types bridges two mass categories, use a single tow bar attachment fitting interface for all of them, and consider the use of the standard dimensions for the higher mass category, be it part of this part of ISO 8267 or ISO 8267-1, throughout the family.

NOTE As far as practical, this part of ISO 8267 was defined in order to be compatible with as many existing aircraft types as possible in the mass category concerned.

2 Normative references

The following referenced documents are indispensable for the application of this document. For dated references, only the edition cited applies. For undated references, the latest edition of the referenced document (including any amendments) applies.

Federal Aviation Regulations (FAR) 14CFR Part 25, *Airworthiness Standards: Transport category airplanes*, paragraph 25.509, Towing loads ¹⁾

Joint Airworthiness Regulations (JAR) Part 25, *Airworthiness Standards: Transport category aeroplanes*, paragraph 25.509, Towing loads ²⁾

3 Terms and definitions

For the purposes of this document, the following terms and definitions apply.

3.1

main line aircraft

civil passenger and/or freight transport aircraft with a maximum ramp mass of > 50 000 kg (110 000 lb)

3.2

regional aircraft

civil passenger and/or freight transport aircraft with a maximum ramp mass of > 10 000 kg (22 000 lb) and ≤ 50 000 kg (110 000 lb)

3.3

maximum ramp mass

MRW

maximum mass allowable for an aircraft type when leaving its parking position either under its own power or towed, comprising maximum structural take-off mass (MTOW) and taxiing fuel allowance

4 Requirements

4.1 Fitting location

The fitting shall be designed to enable simple attachment of the tow bar at the front of the aircraft nose landing gear for push/pull towing operations. No fitting is required at the rear of the nose landing gear.

NOTE An axle fitting may be used in the event of two-wheel nose landing gear. This is acceptable providing the towing loads do not exceed those specified in this part of ISO 8267 and the aircraft is designed accordingly.

1) FAR Part 25 constitute the USA government transport aircraft airworthiness regulations, and can be obtained from the following address:

US Government Printing Office, Mail Stop SSOP, Washington DC 20402-9328, USA.

2) JAR Part 25 constitute the European governments' transport aircraft airworthiness regulations, and can be obtained from the following address:

JAA Headquarters, Saturnsstraat 8-10, P.O. Box 3000, NL 2130 Hoofddrop, Netherlands.

4.2 Towing loads

The aircraft nose landing gear tow bar attachment fitting shall be able to withstand the limit towing loads prescribed in FAR/JAR 25, paragraphs 25.509 (a), (c) and (d), based on the following towing load F_{TOW} (N):

- $F_{TOW} = 0,30 M_r \times g$ (where M_r is the design maximum ramp mass of the aircraft and g is the mean acceleration due to gravity), when $M_r \leq 13\,600$ kg (30 000 lb);
- $F_{TOW} = 6 M_r + \frac{204\,100 \text{ kg}}{70} \times g$, when $13\,600 \text{ kg (30 000 lb)} < M_r \leq 45\,360 \text{ kg (100 000 lb)}$;
- $F_{TOW} = 0,15 M_r \times g$, when $M_r > 45\,360 \text{ kg (100 000 lb)}$.

4.3 Aircraft mass categories

See Table 1.

Table 1 — Aircraft mass categories

Masses in kilograms (Values in pounds in parentheses)

Category	Maximum ramp mass
I	$10\,000 (22\,000) < M_r \leq 22\,680 (50\,000)$
II	$13\,600 (30\,000) < M_r \leq 50\,000 (110\,000)$
The tow bar attachment fitting category shall be selected in such a way that no change of type will become necessary during aircraft development. Aircraft of a design which is near the upper limit of a mass category may be classified in the next higher category to allow for mass growth (see Clause 1).	

4.4 Fitting configuration, dimensions and clearances

The standard configuration of the attachment fitting shall be a horizontal cylindrical pin with the dimensions given in Figure 1 and in Table 2.

Table 2 — Nominal pin dimensions

Dimensions in millimetres (Values in inches in parentheses)

Dimensions	Category	
	I	II
Diameter, A	19,05	25,40
	(0,75)	(1,00)
Length, B	38,10	63,50
	(1,50)	(2,50)

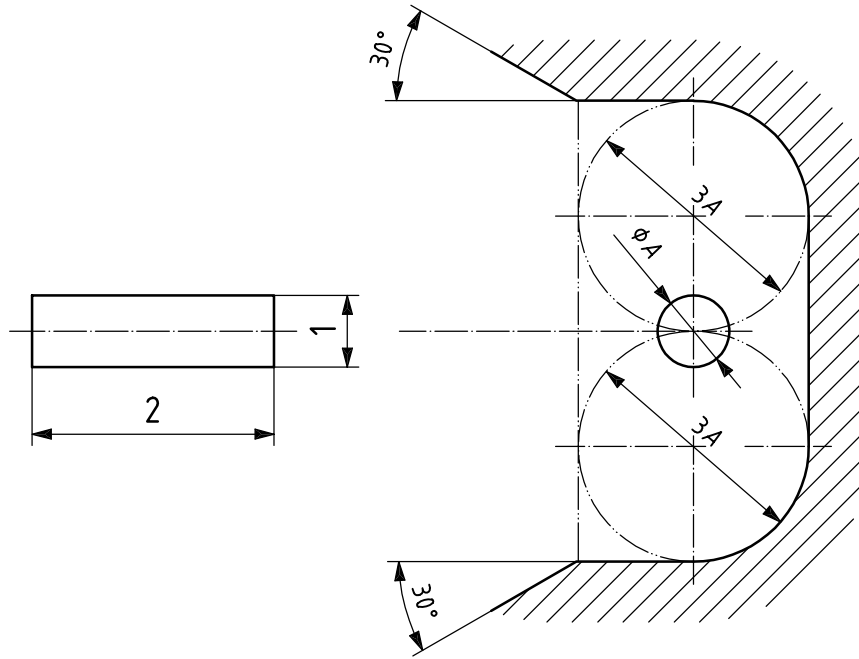

Required space envelope for clearance: $3A$ above and below the towing spool centre.

Key

- 1 diameter A $\begin{matrix} 0 \\ -0,125 \end{matrix}$ mm $\left(\begin{matrix} 0 \\ -0,005 \end{matrix} \right)$ in
- 2 length B $\begin{matrix} +0,5 \\ 0 \end{matrix}$ mm $\left(\begin{matrix} +0,020 \\ 0 \end{matrix} \right)$ in

Figure 1 — Dimensions of the pin

4.5 Tow bar fit

The design of the tow bar device that clamps to the horizontal cylindrical pin shall be such that it

- grips the pin uniformly over 93 % to 95 % of the length (dimension B);
- is adjustable in order to provide positive engagement on the pin when locked.

5 Retrofit option

Where deemed appropriate in order to facilitate operation of such aircraft types at airports, in-service regional aircraft types within the specified maximum ramp mass range, which present tow bar attachment fittings with different dimensions but of an adaptable design, may be rendered compatible with standardized tow bars in conformity with this part of ISO 8267 through simple retrofit modifications. Figure 2 provides an example of such a possible retrofit modification.

Dimensions in millimetres (inches)

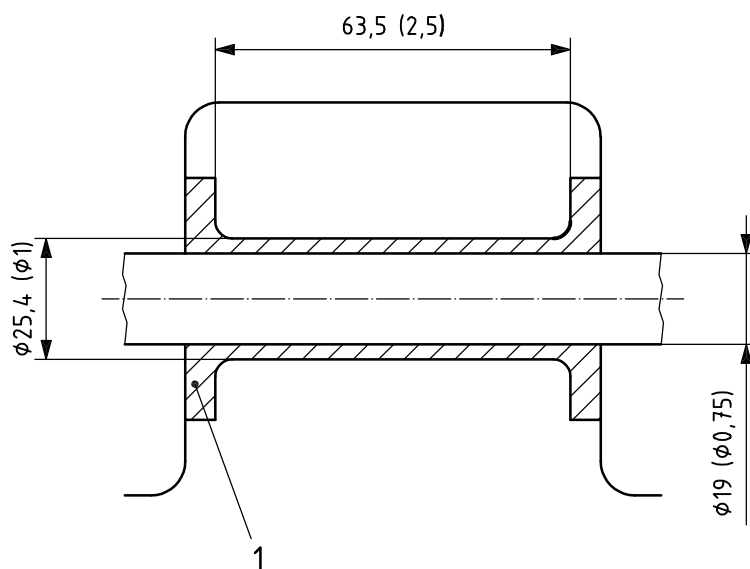
**Key**

- 1 machined steel spacer [mass 0,23 kg (0,5 lb) approx.]

Figure 2 — Example of retrofit modification for 19 mm (0,75 in) diameter, 76 mm (3,00 in) long existing tow bar attachment fitting (plan view cross section)

Bibliography

- [1] ISO 8267-1, *Aircraft — Tow bar attachment fittings interface requirements — Part 1: Main line aircraft*

...

ICS 49.100

Price based on 6 pages