International Standard



8213

INTERNATIONAL ORGANIZATION FOR STANDARDIZATION • МЕЖДУНАРОДНАЯ ОРГАНИЗАЦИЯ ПО СТАНДАРТИЗАЦИИ • ORGANISATION INTERNATIONALE DE NORMALISATION

Chemical products for industrial use — Sampling techniques — Solid chemical products in the form of particles varying from powders to coarse lumps

Produits chimiques à usage industriel — Techniques de l'échantillonnage — Produits chimiques solides de petite granulométrie et agglomérats grossiers

First edition — 1986-07-15

UDC 661 : 62-492 : 620.11

Ref. No. ISO 8213-1986 (E)

Descriptors : industrial products, chemical compounds, granular materials, sampling, sampling equipment.

Foreword

ISO (the International Organization for Standardization) is a worldwide federation of national standards bodies (ISO member bodies). The work of preparing International Standards is normally carried out through ISO technical committees. Each member body interested in a subject for which a technical committee has been established has the right to be represented on that committee. International organizations, governmental and non-governmental, in liaison with ISO, also take part in the work.

Draft International Standards adopted by the technical committees are circulated to the member bodies for approval before their acceptance as International Standards by the ISO Council. They are approved in accordance with ISO procedures requiring at least 75 % approval by the member bodies voting.

International Standard ISO 8213 was prepared by Technical Committee ISO/TC 47, *Chemistry*.

Users should note that all International Standards undergo revision from time to time and that any reference made herein to any other International Standard implies its latest edition, unless otherwise stated.

© International Organization for Standardization, 1986 ●

Printed in Switzerland

Chemical products for industrial use — Sampling techniques — Solid chemical products in the form of particles varying from powders to coarse lumps

1 Scope and field of application

This International Standard describes the general techniques of taking and preparing samples with a view to the assessment of a solid chemical product lot, for use in conjunction with a previously established sampling plan (as described, for example, in ISO 6063 or ISO 6064).

This International Standard is applicable to solid chemical products, in particulate form, ranging from powders to coarse lumps with a maximum size of 100 mm, and consigned in containers (of, for example, 25, 50 or 100 kg) or in bulk.

Massive pieces and solids in a plastic are not dealt with in this International Standard.

NOTE — This International Standard should be used in conjunction with the vocabulary, given in ISO 6206.

2 References

ISO 565, *Test sieves — Woven metal wire cloth and perforated plate — Nominal sizes of apertures.*

ISO 607, *Surface active agents and detergents — Methods of sample division.*

ISO 2591, *Test sieving.*

ISO 3165, *Sampling of chemical products for industrial use — Safety in sampling.*

ISO 6206, *Chemical products for industrial use — Sampling — Vocabulary.*

3 Principle

Taking of a certain number of increments from the lot to be sampled.

Mixing of the increments to form either a bulk sample or several primary samples, depending on the purpose of the sampling.

Preparation by means of replicate reductions, from the bulk sample or from each primary sample, of a reduced sample, then of several laboratory samples, each stage of the division being preceded in each case by blending and, if necessary, by grinding and sieving of the product.

4 Apparatus

GENERAL REMARK — All the apparatus described below must be made of materials inert to the product to be sampled. Moreover, apparatus must cause no contamination, segregation or loss of product.

4.1 Apparatus for sampling and constitution of samples

It is essential that sampling apparatus exhibits only a small systematic error.

Four main types of apparatus can be used, according to circumstances :

4.1.1 Scoop sampler

A scoop of appropriate shape and dimensions, depending on the nature of the product to be sampled, may be used as follows :

- when the material is homogeneous, to take an increment at an easily accessible point in the sampling unit;
- when the material is not homogeneous, to take a sample by the so-called "alternate division" method;

ISO 8213-1986 (E)

- when the material is in motion (in an open chute or on a band conveyor), to take a spot sample or a cross-sectional sample.

A scoop sampler is shown in figure 1.

4.1.2 Probe samplers

There are several types such as those shown in figures 2 to 12. The length of the tube must be such that the withdrawal of the sample can be accomplished right to the bottom of the container or heap and the construction of the probe should be related to the maximum particle size of the material being sampled.

For the products in bulk the most practical and the one least likely to modify the product is the Archimedes' screw sampler (e.g. the apparatus shown in figure 9). The Archimedes' screw is rotated slowly whilst the outer tube, which is tangent to the screw, is thrust into the product.

4.1.3 Samplers of the divider type

These are used to obtain a sample by subdividing the total sampling unit.

These dividers can be either

- stationary dividers (all parts of the apparatus are fixed), or
- moving sample dividers (a part of the apparatus is movable about a vertical or horizontal axis).

Figures 13, 14, 15 and 16 show examples of stationary dividers.

Amongst the more common types are those which divide into 2 equal fractions, such as those indicated on figures 14 and 16 : these samplers consist of a series of slots, with or without a grid of the same dimensions, placed in a parallel direction, but alternately orientated right and left, allowing a division into 2 equal portions. The apparatus is simple and useful, but on the other hand, it can be damaged; a slight deformation of a slot or a grid can involve a systematic error. Furthermore, to reduce the systematic errors, the product must obviously be distributed uniformly on the all slots or over the whole grid. The fixed conical divider [see figure 15 (a or b)] is based on the same principle but the slots are arranged on a circumference.

Figures 17, 18 and 19 give examples of rotary sample dividers which allow a given fraction of the material to be taken.

Moving dividers usually divide a sample into 4, 6, 8 or 10 equal portions, and have either

- a series of receivers arranged in a circle and rotating below one or several fixed hoppers, or
- a mobile hopper rotating above the fixed receivers.

Provided that the design of the apparatus and its method of use allow continuous and uniform feeding, rotary sample dividers will always have very few systematic errors and will be better than stationary dividers.

The stationary and rotary divider should be chosen so that the width of the slots or receivers is at least 3 or 4 times the maximum dimension of the particles.

Plastics dividers can cause segregation of the product due to electrostatic phenomena.

4.1.4 Automatic samplers

Figures 20, 21 and 22 show examples of automatic samplers (continuous or intermittent sampling in a stream of material).

4.2 Other equipment

4.2.1 Crushers and grinders

According to the purpose for which they are required, four types of apparatus may be used :

4.2.1.1 Lump-crushers (e.g. claw-crushers, treadmill type)

These are used to break partly lumpy products.

4.2.1.2 Coarse crushers (e.g. jaw crushers, cone crushers, impact breakers)

These are normally used for primary grinding of coarse products. They generally give a particle size within the range 300 to 10 mm and can be used in the field.

4.2.1.3 Granulating and grinding mills (e.g. hammer, roller and disc mills, etc.)

These are suitable for reducing particles sizes from about 25 mm to less than 1 mm. They can be used in the field, but when samples to be dealt with are relatively small, it is preferable to use a laboratory mill.

4.2.1.4 Laboratory mills

Laboratory mills are similar to the apparatus referred to in 4.2.1.2 and 4.2.1.3 but they are smaller, more proof against contamination, and make it possible to achieve finer grinding, for example

- jaw crushers : particle size 25 to 2 mm;
- hammer mills : particle size 20 mm to 300 μm ;
- roll crushers : particle size 2 mm to 200 μm ;
- disc mills : particle size 2 mm to 75 μm .

4.2.1.5 Manual grinding

For manual grinding, the mortar and pestle or punner and sampling plate are used.

4.2.2 Mixers

For mechanical mixing, numerous types of apparatus exist. The V-type mixers or the completely open double-cone type, for example, are suitable, the latter being filled to not more than one-third of its capacity.

For manual mixing, a scoop may be used for relatively large quantities, a plastic sheet for small quantities.

4.2.3 Sieving equipment

A set of standard test sieves (see ISO 565) is used and the procedures are given in ISO 2591.

5 Procedure

5.1 Introduction

When carrying out the sampling, it is necessary

- to know the sampling unit;
- to know the sampling plan;
- to take the increments and deal with them accordingly.

5.2 General precautions

Any sampling operation must be carried out bearing in mind that the tighter the control specifications, the greater the amount of care and cleanliness that will be required.

It is recommended, and for certain products essential, that the sampling is carried out in an area protected from moisture and in a dust- and fume-free atmosphere avoiding any heating and drying, in order that the properties of the material which are to be evaluated will not be affected during the sampling.

In the case of sampling for measurement of particle size, the size of the particles of the material to be sampled must not be modified and it may therefore be necessary to obtain large samples.

In the case of sampling for chemical analysis, it is possible to reduce the size of the particles and therefore further to divide the sample, and the samples may therefore be smaller.

ISO 3165, relating to safety in sampling, contains the special precautions to be observed in the case of products involving certain risks (see also the International Standards dealing with such products).

Before making a choice of sampling apparatus, it is usually necessary to test the validity by means of preliminary sampling on each type of product (examination of reproducibility and bias from several increments).

5.3 Definition of a sampling unit

5.3.1 Products packed in containers (bags, drums, etc.)

The sampling unit is the container, if the latter can be handled at the time of sampling. Where the contrary is the case, see 5.3.3.

5.3.2 Products in bulk, during loading and unloading

If the transfer is made by means of pick-up apparatus (e.g. crane bucket, or automatic scoop), the sampling unit is defined

as the quantity of material corresponding to one pick-up operation. When this operation is carried out, at least partly, by continuous apparatus (conveyor belts, pneumatic equipment, etc.), the sampling unit is defined by a certain product weight (for example, 50 kg) transferred during the operation.

5.3.3 Products in bulk, during transportation (by ships, rail-trucks, lorries, containers, etc.) or stocked in a heap

The sampling unit remains hypothetical. The lot is mentally divided into a certain number of these sampling units of defined weight (for example, 200 kg).

Some of these units in the inner part of the lot are difficult to get at or even inaccessible. This is why it is recommended that sampling of products in bulk should be carried out, unless it is impossible, at the time of loading or unloading (5.3.2).

5.4 Sampling plan

The sampling plan indicating the number of sampling units, the number and mass of the increments and, should the case arise, the number of primary samples to be constituted by suitable grouping of increments, is established on statistical bases. All these parameters depend upon the heterogeneity of the product, on the sampling precision required and on the purpose of the sampling.

5.5 Choice of sampling units

This choice is made at random, for example by using a table of random numbers (see annex A).

Exception : In the case of small lots including only a limited number of units, the sampling plan may provide for taking the units as a whole.

5.5.1 Products packed in containers (sacks, drums, etc.)

Begin by numbering all the containers in the lot : 1, 2, 3, 4, etc., then draw at random the numbers of the N containers to be sampled.

5.5.2 Products in bulk, during loading or unloading

Knowing the mass of the lot and the mass of the sampling unit (e.g. 50 kg), begin by calculating the total number of sampling units contained in the lot. Number the sampling units in chronological order of their actual formation (pick-up apparatus) or of their virtual formation (continuous apparatus).

In the latter case, this involves numbering the lapses of time, taking account of the flow rate of the apparatus.

Choose at random N sampling units. In the case of pick-up apparatus, withdraw and set aside the N sampling units to be sampled. Where continuous apparatus (stream of material) is involved, make up the N sampling units of defined mass (e.g. 50 kg) by cross-sectional sampling, and collect them separately. In the case of band conveyors, stop the apparatus for the time necessary to make the withdrawal.

ISO 8213-1986 (E)

Automatic samplers (4.1.4) allow the bulk sample to be obtained directly from a stream of material in an open or closed chute or on a band conveyor.

5.5.3 Products in bulk, during transportation (by ships, rail-trucks, lorries, etc.) or stocked in heaps

Mentally divide the lot into hypothetical sampling units of given weight (e.g. 200 kg) or equal parts, number them and draw the sampling unit numbers at random.

5.6 Taking samples from the sampling unit

As a rule, one sample should be obtained per sampling unit, the purpose being to produce a sample as representative as possible of the sampling unit. The samples should each have approximately the same mass.

5.6.1 Products packed in containers (bags, drums, etc.)

5.6.1.1 Products in the form of powder, granules and crystals

Make sure that the product is not agglomerated in lumps, by emptying out completely the containers. Should this be the case, begin by crumbling the lumps, avoiding any crushing of the particles.

Take the sample from each container, chosen as in 5.5.1, proceeding as indicated below :

- a) Use a divider (see 5.6.6).
- b) If a divider cannot be used, use the quartering method (see 5.6.7).

NOTE — These two processes both result in a sample which is the most representative of the container sampled.

If these methods are impossible

- c) Use a screw probe (directional sampling) (see 5.6.5) or some other type of apparatus whose absence of bias has been previously ascertained.
- d) In the case of a product the uniform distribution of which is proved, take an increment with a scoop (see 5.6.4). If possible, several fragmentary increments should be taken from two or three easily accessible places in the container and these should then be collected together to form the sample of the container (spot sample).

5.6.1.2 Coarse and lumpy products

Products in the form of coarse particles and lumps which do not crumble easily and the coarsest of which may have a size in the region of 100 mm may be dealt with as follows.

If it is not necessary to keep the product in its initial state, grind the contents of each container to be sampled in such a way that they pass completely through a sieve of suitable size. After

passage through the sieve and blending, proceed as indicated in 5.6.1.1.

If it is necessary to keep the product in its initial state, proceed directly to sampling as indicated in 5.6.1.1, but do not use probe samplers which may modify the particle size.

5.6.2 Products in bulk, during loading or unloading

The sampling units having been selected and, if necessary, collected separately as indicated in 5.5.2, proceed with sampling in the same way as in 5.6.1.

5.6.3 Products in bulk, during transportation (by ships, rail-trucks, lorries, containers, etc.) or stocked in heaps

The hypothetical sampling units having been selected as indicated in 5.3, locate them on the conveyor vehicle or on the heap and take the increments using a probe of appropriate length (see 5.6.5).

5.6.4 Sampling with a scoop

5.6.4.1 Product known to be homogeneous

Thrust the scoop (4.1.1) into the required place (spot sample) in the sampling unit, withdraw it and level off to the edges of the scoop.

If necessary, repeat the operation two or three times, at different places, in order to obtain a sample of the required mass (see sampling plan).

5.6.4.2 Alternate division procedure

This method can be used in certain cases, and in particular in the case of preparation, from a bulk sample, of samples for moisture, when other methods would result in an absorption or an appreciable loss of water.

Operate in the following way (see figure 23).

- a) Spread out the bulk sample on a flat, smooth plate, which does not absorb moisture, to make a flat, uniform rectangle the thickness of which is a function of the maximum particle size of the product.
- b) Divide the rectangle, for example into 5 equal parts lengthwise and 4 equal parts widthwise (if 20 parts are required by the sampling plan).
- c) Using a flat-bottom scoop (figure 1) of appropriate dimensions, which are a function of the maximum particle size of the product, take a scoopful of the bulk sample from each fraction obtained in b) (the sampling site being chosen at random in each fraction) and mix the 20 scoopfuls to form the required sample.

In the above operation, the scoop must be thrust into the section of the bed by gliding on the surface, to collect the whole thickness of the spread layer in a single movement. It is recommended that a metallic plate be thrust the height of

the spread layer and be pressed vertically on the surface, in front of the scoop making its movement of horizontal translation.

5.6.4.3 Material in motion

In the case of material falling freely in a stream, put a scoop (4.1.1) of sufficient size to hold the required quantity of sample without spilling over, upside down in the stream, turn right side up and collect a spot sample or a cross-sectional sample, depending on the case, and quickly remove the scoop from the stream (see figure 24).

When width and depth of the stream are both greater than the width of the scoop, the cross-sectional sample is taken by the following technique.

Divide mentally the width or the depth of the stream into n sections, move the scoop from front to rear of the stream (or vice versa) or from side to side in each section and then combine the samples of the sections to give the cross-sectional sample. The rate of movement of the scoop through the stream should be uniform through any section of the stream and should be the same for each section. The whole operation should be carried out as quickly as possible so that variation of the material with time is not included in the cross-sectional samples.

In the case of material in motion on a band conveyor, stop the conveyor and collect with a scoop of appropriate dimensions a spot sample or a cross-sectional sample. When the width of the band is such that capacity of the scoop is not sufficient to take a cross-sectional sample in one operation, a suitable rectangular frame may be placed across the band, and displaced perpendicular to the axis of the band to collect the complete cross-section of the material in a container.

The frame should be inserted in the material until it is in contact with the band across its full width.

5.6.5 Sampling with a screw probe

Take an increment or increments by referring to the sampling "grid" defined in the International Standard relevant to the product in question. For each increment (spot sample), thrust the probe (4.1.2) into the sampling unit, turning the screw so that the probe penetrates into the product without compressing it in front of the probe. In the case of a container, thrust the probe to the bottom (directional sample).

Blend the increments together.

If necessary, repeat the operations two or three times in order to obtain a sample of the required mass (see sampling plan). In this case, the paths of the probe should criss-cross, if possible.

5.6.6 Sampling with a divider

Whatever the type of divider used, it is essential to reduce the causes of systematic errors to a minimum, that no material should fly about during the operations and that introduction of the product should be slow enough, continuous and uniform (no preferential way).

5.6.6.1 Moving sample dividers

Start up the divider and, when it is running at a steady speed, pass through it the whole of the sampling unit.

If the mass of the different fractions obtained is not suitable (see sampling plan), again run one of the fractions or several fractions previously combined through the divider. By divisions and successive rearrangements, a sample of a required mass is finally obtained.

On the other hand, in cases where it is decided to obtain from the initial mass of product a number n of equal representative fractions [for example case of preparation of n laboratory samples from a reduced sample (see 5.9)], n being higher or lower than the number of receivers of the divider, it may also be obtained by a series of suitable divisions and rearrangements.

In some cases the whole of the sampling unit will be used to form the final fractions; in other cases there will be a small residue. The process followed must be such that it entails minimum work with minimum loss. For example, figure 25 gives the scheme of division and combination in cases where 10 equal representative fractions must be obtained, with a divider into 8.

5.6.6.2 Stationary dividers

Start up the divider and, when it is running at a steady speed, pass through it the whole of the sampling unit.

A sampler that will divide into 2 should preferably be used (e.g. apparatus shown in figure 14) because with this type of divider, it is possible to reduce the systematic errors, by operating according to the compensation method described below.

This method consists of carrying out one stage of division more than necessary and combining fractions following certain rules. For example, figure 26 shows the scheme to be followed in the case of division into 8 equal representative fractions ($2^3 = 8$ fractions).

The individual fractions are designated by permutations of the numerals 1 and 2. The numeral 1 indicates that at that stage of the process of division the product has been collected to the right and the numeral 2 indicates it has been collected to the left. Thus, the code 2.1.2 indicates that the fraction has been collected :

- to the left (2), during the first division;
- to the right (1), during the second division;
- to the left (2), during the third division.

The scheme of the division has an axis of symmetry : A — A. After the fourth stage of division, the 2 fractions arranged symmetrically about the axis A — A are combined. Thus, for example, the fraction 1.2.2.1 with the fraction 2.1.1.2.

This method allows compensation mainly of the systematic cumulative errors, without, however, eliminating them. The different fractions obtained do not have the same value for representativity : the reduction of error is more effective for the fractions located near the axis of symmetry than for the fractions which are farther away.

ISO 8213-1986 (E)

For taking a sample from a whole sampling unit, or for reducing a sample, follow the same process as that indicated in the above example, but, after a first division into fractions 1 and 2, carry out each successive division using one of the fractions obtained and discard the other. Retain finally the fractions nearest the axis of symmetry in the diagram. In the above example, the fractions 1.2.2.2 and 2.1.1.1 will be retained and then combined to obtain a representative sample of mass equal to 1/8 of the initial mass.

5.6.7 Sampling by quartering

Place the entire sampling unit arranged in a conical heap, on a flat, hard surface. Ensure that the heap is quite symmetrical. Flatten the top of the cone with a plate held horizontally and applied with a circular motion. Divide the pile thus obtained into 4 equal sectors by means of 2 large blades or slats, along 2 mutually perpendicular lines intersecting at the centre of the pile. Separate the quarters from each other. Continue by discarding 2 opposite quarters, mixing the other 2 quarters well and forming a fresh cone. Continue subdividing in the same way until a sample of the required mass is obtained (see sampling plan).

As in the case of use of a divider into 2 (5.6.6.2), it is possible to reduce the inherent errors of handling by carrying out one stage of division more than necessary and combining the last fractions following certain rules. Figure 27 shows a diagram of the procedure of divisions and rearrangements: the four quarters of cone obtained at the end of the operation, each already having the required mass, are subdivided separately to give 16 fractions, which are rearranged 4 by 4 following the diagram (figure 27).

On the other hand, a given number n of equal representative fractions (n being equal to a power of 2) can be obtained from a certain initial mass following the same principle as that described in 5.6.6.2 in the case of division into 8 fractions ($2^3 = 8$ fractions).

5.6.8 Storage of samples

In all cases, place the sample in a perfectly clean, dry, contamination-proof container which closes hermetically.

5.7 Preparation of bulk sample or primary samples

5.7.1 Number of samples to be prepared, N'

This is given by the sampling plan.

If $N' = 1$, a bulk sample is to be prepared.

If $N' > 1$, several primary samples are to be prepared.

5.7.2 Preparation of bulk sample

Collect all the increments in one perfectly clean, dry container which can be hermetically sealed. The contents of this container constitute the bulk sample.

5.7.3 Preparation of primary samples

The number of increments to be collected in order to obtain one primary sample is equal to

$$\frac{N''}{N'} = k$$

where

N' is the number of primary samples.

N'' is the total number of increments taken from the sampling unit.

$\left(\frac{N''}{N'}\right)$ is rounded off so that k is a whole number.

The N'' increments should be grouped in such a way as to obtain N' primary samples.

Proceed as follows.

Number the increment containers 1, 2, 3, etc.

Prepare N' clean, dry containers which can be hermetically closed.

In the first container, place the increments numbered 1 to k ; then in a second container, place the increments numbered $(k + 1)$ to $2k$; then in a third container, place the increments numbered $(2k + 1)$ to $3k$, etc. The contents of each of these containers constitute one of the primary samples.

5.8 Preparation of reduced samples

The bulk sample or primary samples must be reduced until a limiting mass is obtained as defined by the sampling plan and as required for

— physical tests (e.g. particle size distribution) (in which case, the product to be examined must have been kept in its original state, without grinding);

— or chemical tests;

NOTE — The sample for physical tests is usually larger than that required for chemical tests. The sample for physical tests must be kept as it is, whilst a second equivalent portion will have to be divided and possibly ground until the limiting mass of the sample is obtained.

— or determination of moisture content.

NOTE — The sample for moisture content is essential in order to ascertain the moisture content of certain products at the time of sampling. Determination of this moisture content is then made from a "moisture sample" taken by dividing up a reduced sample or even from the sample before reduction, without grinding. Additional precautions must be taken to avoid absorption or loss of moisture. Should the occasion arise the moisture sample may be obtained by the alternate division method (5.6.4.2).

Before reduction of the sample (bulk sample or primary sample), blend as thoroughly as possible by means of an apparatus (4.2.2) or, failing this, manually.

Make the reduction by using a divider (see 5.6.6) or by the quartering method (see 5.6.7). After separation of the sample possibly required for physical tests, continue the reduction, ensuring before each proportional reduction that the material is in sufficiently fine-grained form (the latter is imposed by the mass of the reduced portion) (see the sampling plan). Otherwise, it will be advisable to reduce the particles of the product to the required size by grinding then sieving (with no remainder). As a rule, unless otherwise indicated by the sampling plan, the particle size of the bulk sample or primary samples, after separation from the sample set aside for any physical test, should not exceed 1 mm and, when reduction has been completed, 0,2 mm.

The sample or reduced samples shall be transported and stored in containers which are perfectly clean, dry and contamination-proof and which can be hermetically closed.

5.9 Preparation of laboratory samples

Using an unbiased divider, divide each of the reduced samples into as many laboratory samples as are required. Place them in clean dry containers. Seal and label these containers.

6 Sampling report

The sampling report shall contain the following information :

- a) all necessary details for the complete identification of the sample (name and description of the product, supplier, place and date of sampling, number and definition of sampling units, tonnage, etc.);
- b) number of sampling units;
- c) number and mass of increments;
- d) number and type of prepared samples (bulk sample, primary samples, reduced samples, laboratory samples) together with their mass;
- e) nature and type of apparatus used;
- f) any unusual features such as : abnormal appearance, pollution, presence of lumps;
- g) any operations not specified in the relevant International Standard or in the International Standards to which reference is made, or regarded as optional, as well as any incidents likely to have affected the sampling.

Annex A

Table of random numbers — Method of use for sampling

(This annex forms an integral part of the Standard.)

To obtain n numbers drawn at random, within the N series of whole numbers : 1, 2, 3, ..., N , proceed as follows, using the table.

a) If $N < 9$

Take the numbers which occur in any single column or any single line of the table, eliminating those above N or those which have already been taken, continuing until n figures are obtained.

Example :

5, 9, 4, 2, 1, etc., any given column

1, 9, 4, 2, 8, etc., any given line

b) If $10 < N < 99$

Take the two-figure numbers (the first may be 0) which occur in any single column or any single line of the table, eliminating those above N or those which have already been taken, continuing until n figures are obtained.

Example :

01, 53, 92, 41, 24, 18, etc., any given column

01, 10, 91, 40, 28, 04, 80, 46, etc., any given line

If the number of readings in any column (or any line) is less than n , continue the readings in the same way in another column (or another line). Always take care to choose columns or lines which have not been used before.

c) If $100 < N < 999$ or $1\ 000 < N < 9\ 999$

Proceed as before, but taking three-figure numbers (the first two may be 0) up to 999, and four-figure numbers (the first three may be 0) up to 9 999.

Table (part 1) — Random sampling numbers

0110	9140	2804	8046	7142	6277	6210	8627	3209	6845
5327	3946	6289	6117	0060	2827	6546	2738	8760	6604
5373	8259	4956	8185	0135	8640	7410	6335	0831	2774
9244	9452	8324	8062	9817	9853	7479	9559	4264	6919
4148	3948	5399	8687	3568	4046	4558	0705	5075	4440
2403	4351	8240	3554	3568	4701	7494	6036	7735	4082
1828	1956	1646	1370	9096	0738	8015	0513	6969	0949
7249	9634	4263	4345	0567	1272	5302	3352	7389	9976
7116	9731	2195	3265	9542	2808	1720	4832	2553	7425
6659	8200	4135	6116	3019	6223	7323	0965	8105	4394
2267	0362	5242	0261	7990	8886	0375	7577	8422	5230
9460	9813	8325	6031	1102	2825	4899	1599	1199	0909
2985	3541	6445	7981	8796	9480	2409	9456	7725	0183
4313	0666	2179	1031	7804	8075	8187	6575	0065	2170
6930	5368	4520	7727	2536	4166	7653	0448	2560	4795
8910	3585	5655	1904	0681	6310	0568	3718	3537	8858
8439	1052	5883	9283	1053	5667	0572	0611	0100	5190
4691	6787	4107	5073	8503	6875	7525	8894	7426	0212
1034	1157	5888	0213	2430	7397	7204	6893	7017	7038
7472	4581	3837	8961	7931	6351	1727	9793	2142	0816
2950	7419	6874	1128	5108	7643	7335	5303	2703	8793
1312	7297	3848	4767	5386	7361	2079	3197	8904	4332
8734	4921	6201	5057	9228	9938	5104	6662	1617	2323
2907	0737	8496	7509	9304	7112	5528	2390	7736	0475
1294	4883	2536	2351	5860	0344	2595	4880	5167	5370

Table (part 2) — Random sampling numbers

0430	5819	7017	4512	8081	9198	9786	7388	0704	0138
5632	0752	8287	8178	8552	2264	0658	2336	4912	4268
7960	0067	7837	9890	4490	1619	6766	6148	0370	8322
5138	6660	7759	9633	0924	1094	5103	1371	2874	5400
8615	7292	1010	9987	2993	5116	7876	7215	9714	3906
4968	8420	5016	1391	8711	4118	3881	9840	5843	0751
9228	3252	5804	8004	0773	7886	0146	2400	6957	8968
9657	9617	1033	0469	3564	3799	2784	3815	3611	8362
9270	5743	8129	8655	4769	2900	6421	2788	4858	5335
8206	3008	7396	0240	0524	3384	6518	4268	5988	9096
1562	7953	0607	6254	0132	3860	6630	2865	9750	9397
1528	4342	5173	3322	0026	7513	1743	1299	1340	6470
5697	9273	8609	8442	1780	1961	7221	5630	8036	4029
3186	0656	3248	0341	9308	9853	5129	3956	4717	7594
3275	7697	1415	5573	9661	0016	4090	2384	7698	4588
7931	1949	1739	3437	6157	2128	6026	2268	5247	2987
5956	2912	2698	5721	1703	2321	8880	3288	7420	2121
1866	7901	4279	4715	9741	2674	7148	8392	2497	8018
2673	7071	4948	8100	7842	8208	3256	3217	8331	7256
7824	5427	0957	6076	2914	0336	3466	0631	5249	7289
2251	0864	0373	7808	1256	1144	4152	8262	4998	3315
7661	8813	5810	2612	3237	2829	3133	4833	7826	1897
6651	6718	1088	2972	0673	8440	3154	6962	0199	2604
2917	4989	9207	4484	0916	9129	6517	0889	0137	9055
5970	3582	2346	8356	0780	4899	7204	1042	8795	2435

Table (part 3) — Random sampling numbers

1564	8048	6359	8802	2860	3546	3117	7357	9945	5739
6022	9676	5768	3388	9918	8897	1119	9441	8934	8555
8418	9906	0019	0550	4223	5586	4842	8786	0855	5650
5948	1652	2545	3981	2102	3523	7419	2359	0381	8457
6945	3629	7351	3502	1760	0550	8874	4599	7809	9474
0370	1165	8035	4415	9812	4312	3524	1382	4732	2303
6702	6457	2270	8611	8479	1419	0835	1866	1307	4211
3740	4722	3002	8020	0182	4451	9389	1730	3394	7094
3833	3356	9025	5749	4780	6042	3829	8458	1339	6948
8683	7947	4719	9403	7863	0701	9245	5960	9257	2588
6794	1732	4809	9473	5893	1154	0067	0899	1184	8630
5054	1532	9498	7702	0544	0087	9602	6259	3807	7276
1733	6560	9758	8586	3263	2532	6668	2888	1404	3887
6609	6263	9160	0600	4304	2784	1089	7321	5618	6172
3970	7716	8807	6123	3748	1036	0516	0607	2710	3700
9504	2769	0534	0758	9824	9536	7825	2985	3824	3449
0668	9636	6001	9372	8746	1579	6102	7990	4526	3429
4364	0606	4355	2395	2070	8915	8461	9820	6811	5873
8875	3041	7183	2261	7210	6072	7128	0825	8281	6815
4521	3391	6695	5986	2416	7979	8106	7759	6379	2101
5066	1454	9642	8675	8767	0582	0410	5515	2697	1575
9138	5003	8633	2670	7575	4021	0391	0118	9493	2291
0975	1836	7629	5136	7824	3916	0542	2614	6567	3015
1049	9925	3408	3029	7244	1766	1013	0221	8492	3801
0682	1343	7454	8600	8598	9953	5773	6482	4439	6708

Table (part 4) — Random sampling numbers

0263	4909	9832	0627	1155	4007	0446	6988	4699	1740
2733	3398	7630	3824	0734	7736	8465	0849	0459	8733
1441	2684	1116	0758	5411	3365	4489	6241	6413	3615
5014	5616	1721	8772	4605	0388	1399	5993	7459	4445
3745	5956	5512	8577	4178	0031	3090	2296	0124	5896
8384	8727	5567	5881	3721	1896	3758	7236	6860	1740
9944	8361	7050	8783	3815	9768	3247	1706	9355	3510
3045	2466	6640	6804	1704	8665	2539	2320	9831	9442
5939	5741	7210	0872	3279	3177	6021	2045	0163	3706
4294	1777	5386	7182	7238	8408	7674	1719	9068	9921
3787	2516	2661	6711	9240	5994	3068	5524	0932	5520
4764	2339	4541	5415	6314	7979	3634	5320	5400	6714
0292	9574	0285	4230	2283	5232	8830	5662	6404	2514
7876	1662	2627	0940	7836	3741	3217	8824	7393	7306
3490	3071	2967	4922	3658	4333	6452	9149	4420	6091
3670	8960	6477	3671	9318	1317	6355	4982	6815	0814
3665	2367	8144	9663	0990	6155	4520	0294	7504	0223
3792	0557	8489	8446	8082	1122	1181	8142	7119	3200
2618	2204	9433	2527	5744	9330	0721	8866	3695	1081
8972	8829	0962	5597	8834	5857	9800	7375	9209	0630
7305	8852	1688	3571	3393	2990	9488	8883	2476	9136
1794	4551	1262	4845	4039	7760	1565	4745	1178	8370
3179	1304	7767	4769	7373	5195	5013	6894	5734	5852
2930	3828	7172	3188	7487	2191	1225	7770	3999	0006
8418	9627	7948	6243	1176	9393	2252	0377	9798	8648

Annex B

Figures and examples of apparatus for sampling

(This annex forms an integral part of the Standard.)

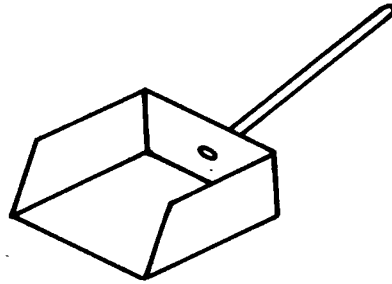

Figure 1 — Scoop sampler (see 4.1.1)

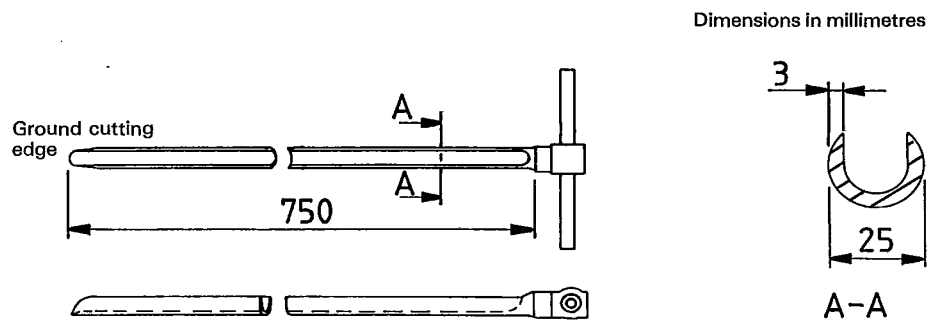

Figure 2 — Open-end sampling spear

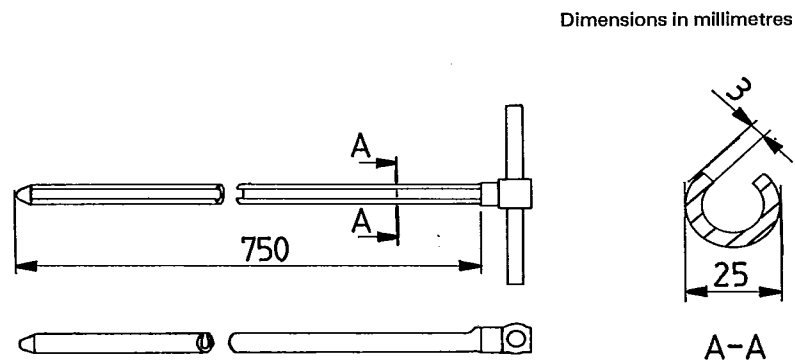

Figure 3 — Closed-end sampling spear

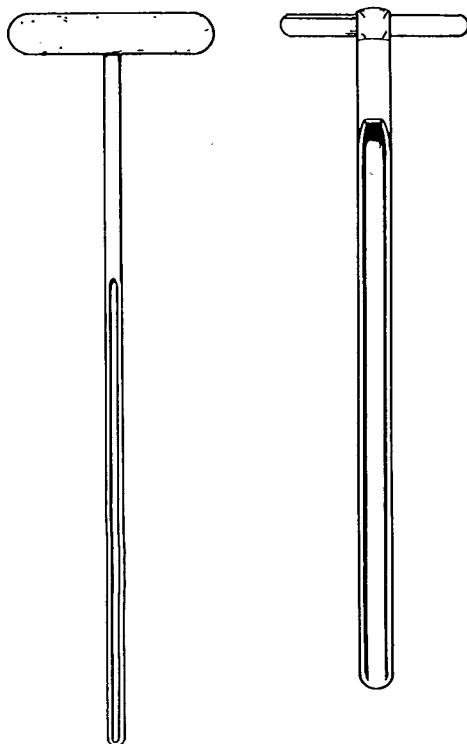

Figure 4 — Further designs of open-end sampling spears

For apparatus shown in figures 2, 3 and 4 :

Applications : Granular (or powdery) solids.

Method of use : Thrust the spear at an angle into the material with its open side underneath and give it two or three turns. With the open side uppermost, withdraw the spear carefully so that it remains filled with the material, which is then discharged into the sample container.

Dimensions in millimetres

Applications : Free-flowing solids, not for extremely free-flowing materials, not for sample used for measurement of particle size.

Method of use : Check that the spear is clean, using a "pull through" if necessary. Insert the inner tube into the outer one and check that the tubes can be rotated relative to one another without difficulty.

Rotate the inner tube until either all the slots match up (if a representative or directional sample is required) or the two lower slots match up (if a spot sample is required). Check that the reference marks on the collars correspond. Then rotate the inner tube until the handles are at right angles to one another; in this position the slots should be closed.

Insert the spear steadily into the required position in the material being sampled, twisting it slightly to ease its passage. It is preferable to insert it horizontally or inclined to the vertical, with the slots in the outer tube on the upper surface. Rotate the inner tube until the appropriate reference marks on the collars coincide, thus opening the slots. Tap the end of the tube or work it about to encourage material to flow through the slots. Rotate the inner tube until the handles are again at right angles to close the slots and withdraw the spear. Empty the spear by tipping out the sample from the open handle end of the tube. Withdraw the inner tube from the outer, clean if necessary and repeat the procedure for the next sample.

If particles of material get jammed between the two tubes and prevent rotation one within the other, discard the inner tube and replace it with a looser fitting rod of metal or hard wood which is about 150 mm longer than the outer tube. Push the rod into the outer tube. Insert the outer tube into the required position in the material being sampled. Slowly withdraw the rod from the tube, completely for a representative or directional sample, or partially for a spot sample, to permit material to flow through the slots. Withdraw the spear and empty it as before. This procedure can be used only if the spear is in a position considerably inclined to the vertical.

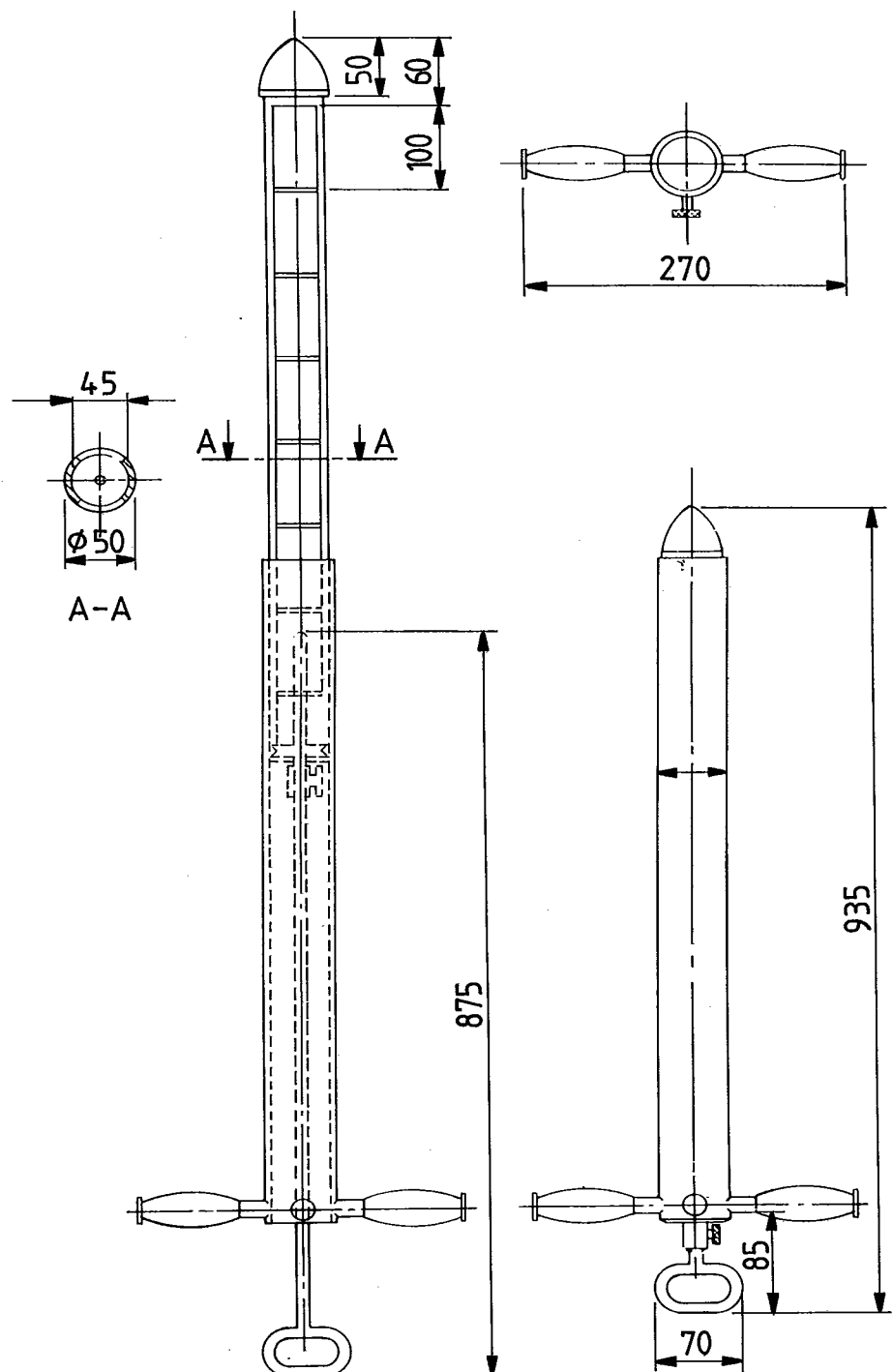

Figure 5 — Closable sampling spear

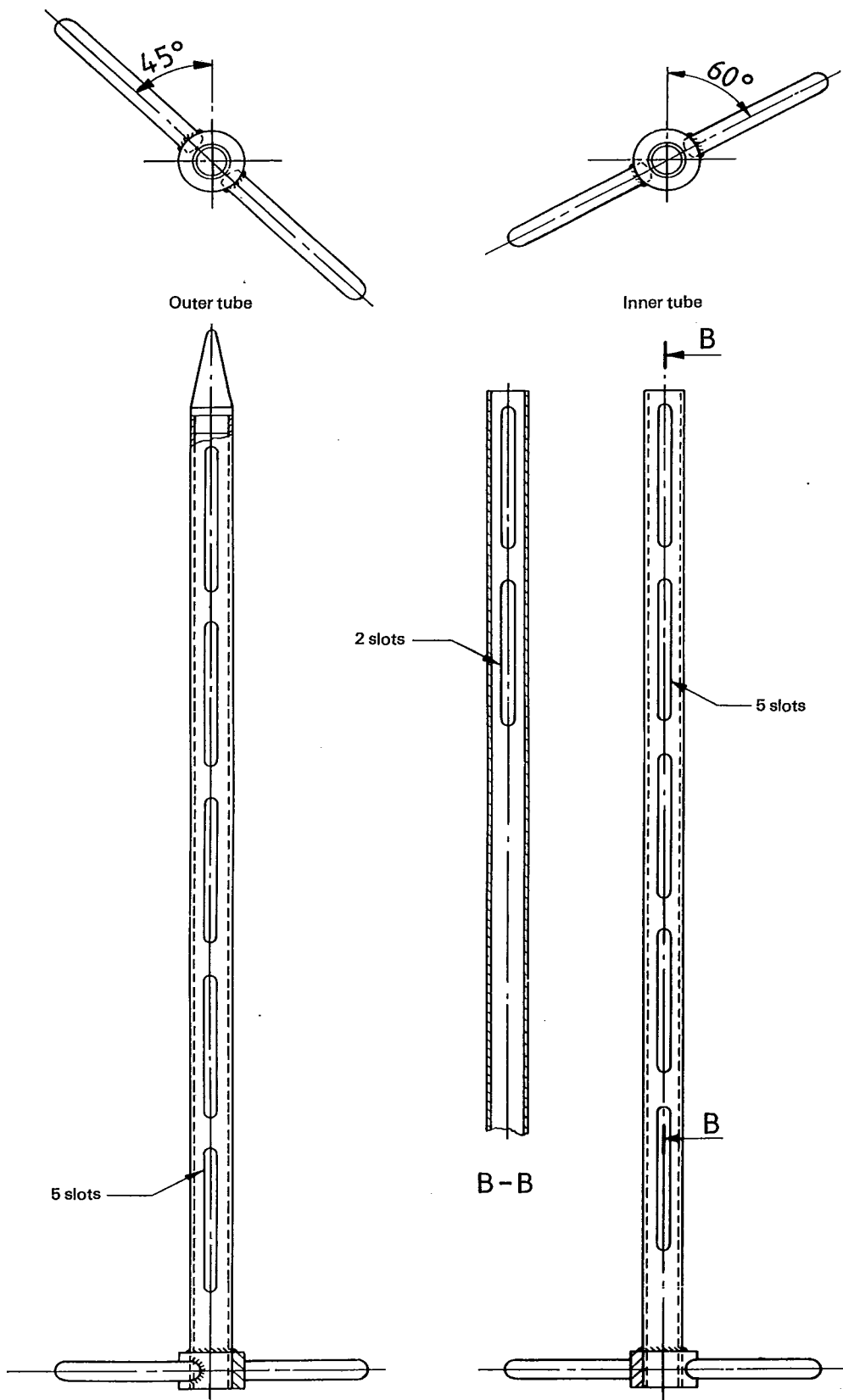
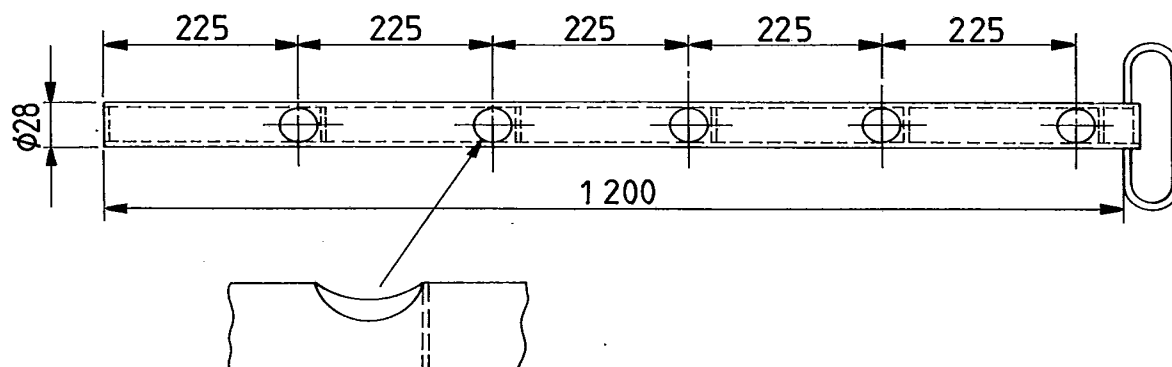

Figure 6 — Shuttered sampling spear

Dimensions in millimetres



Application : Free flowing solids

Method of use : Identical to that of apparatus shown in figures 5 and 6.

Figure 7 — Tubular sampling spear



Figure 8 — Simple auger (see 4.1.2)

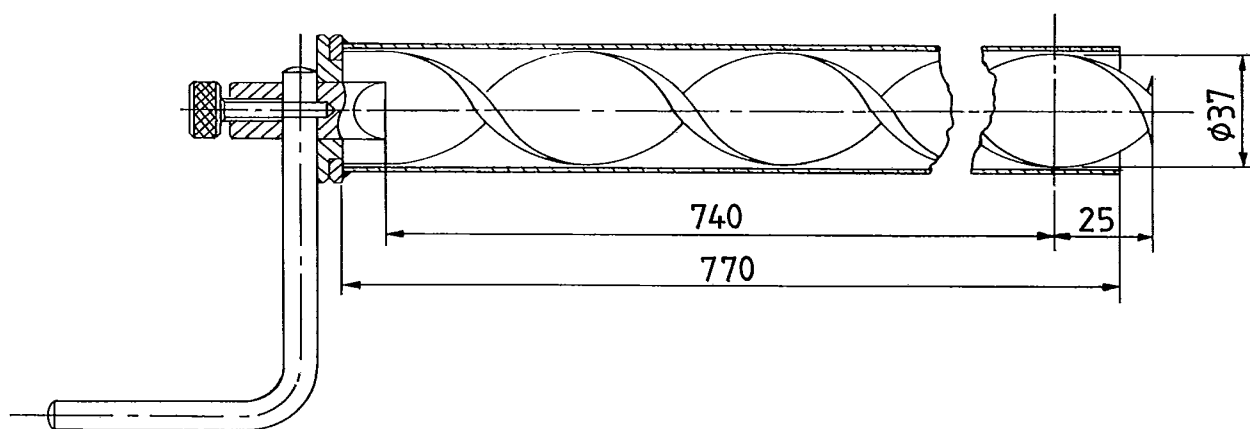

Figure 9 — Shuttered sampling auger (Archimedes) (see 4.1.2)

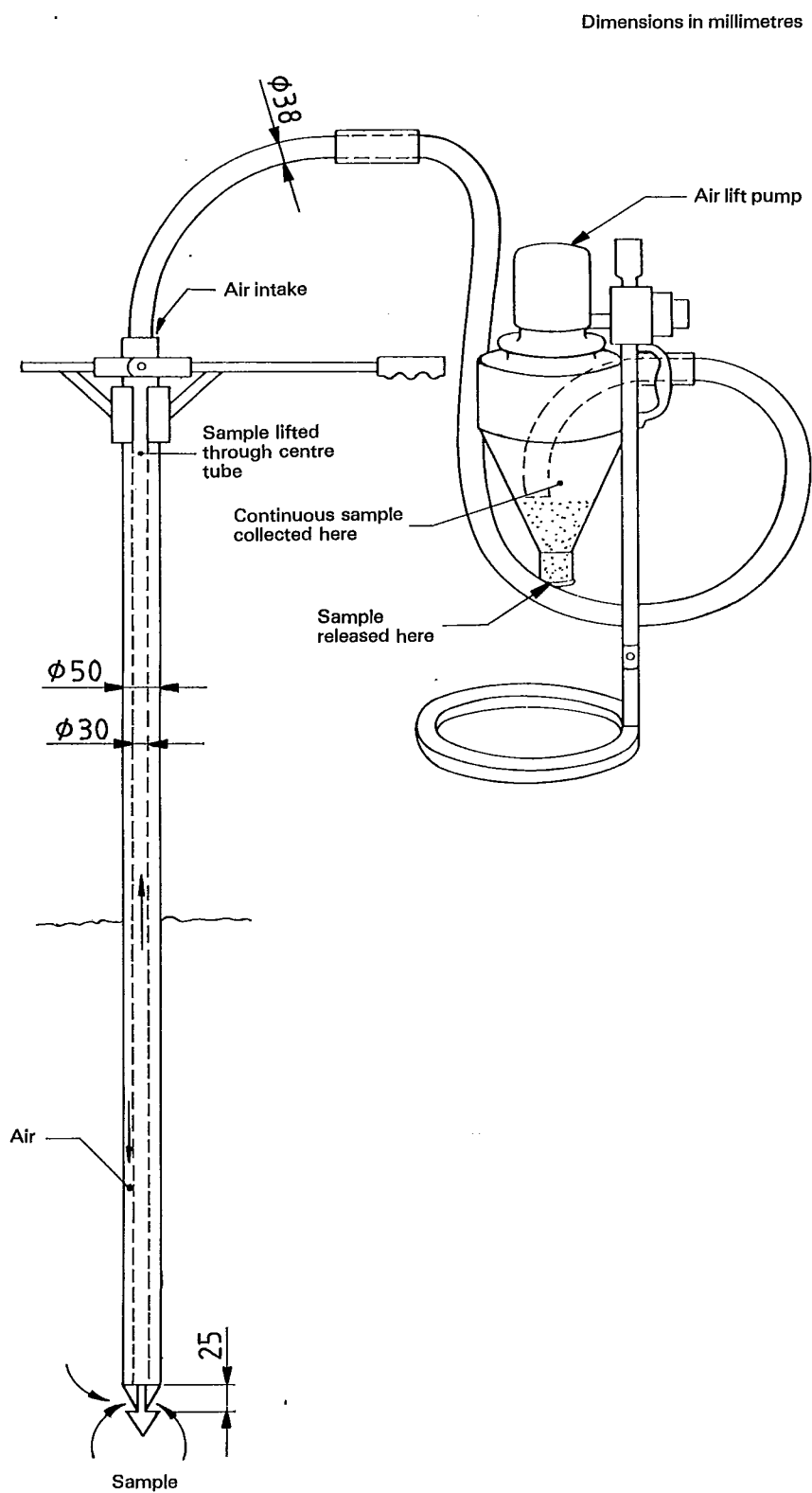
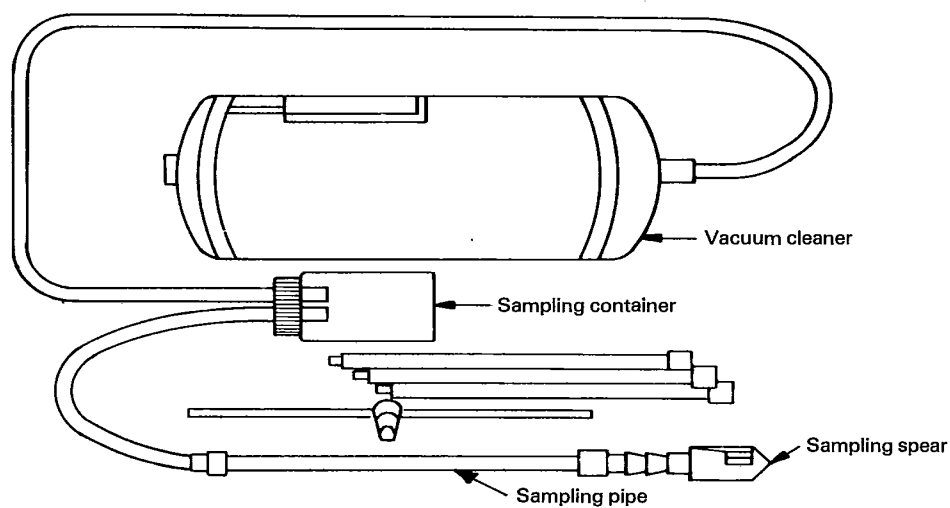

Figure 10 — Pneumatic probe sampler (see 4.1.2)



NOTE — A filter is required at the exit of the sampling container to prevent loss of fines.

Figure 11 — Suction sampling device (see 4.1.2)

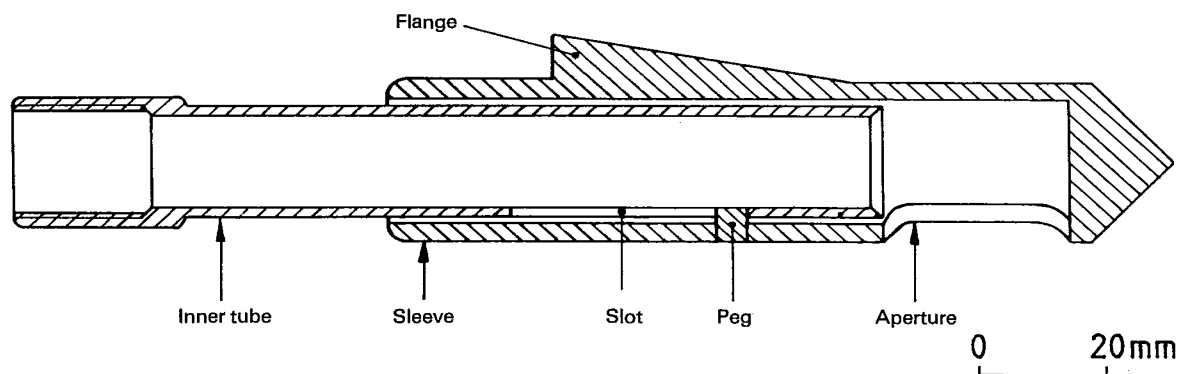

Figure 12 — Spear for suction sampling device (see 4.1.2)

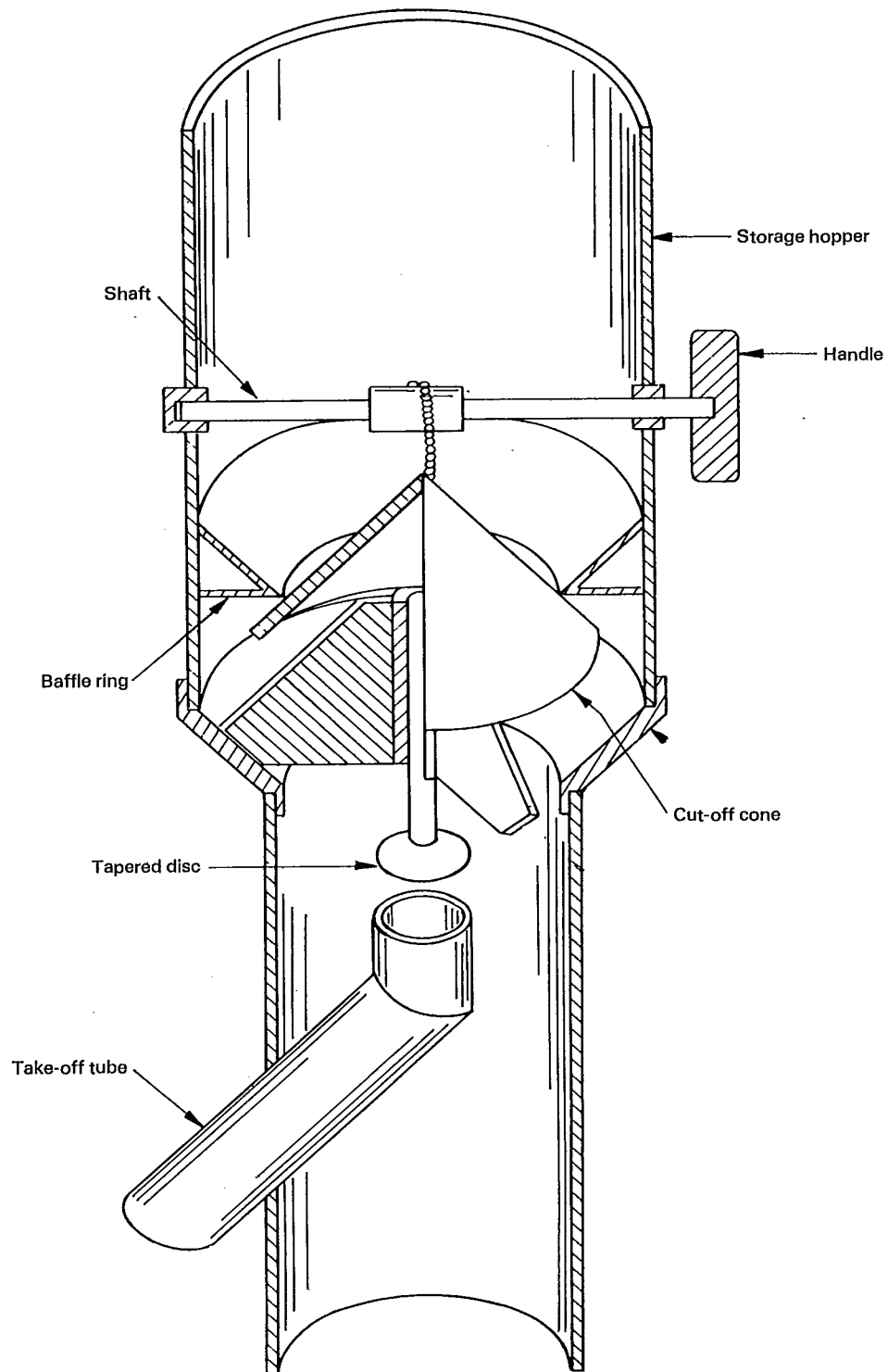

Figure 13 — Granular material sampler (see 4.1.3)

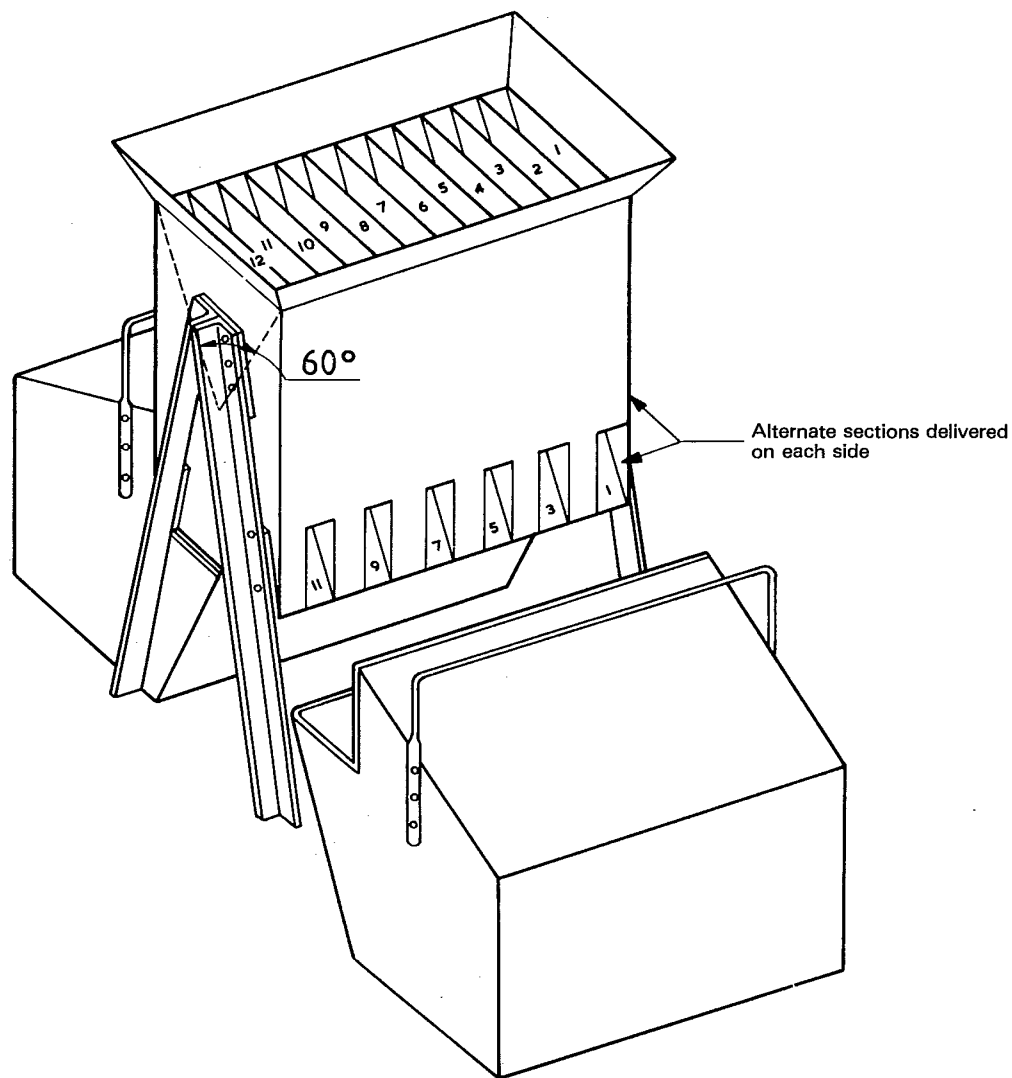

Figure 14 — Riffle sample divider (see 4.1.3)

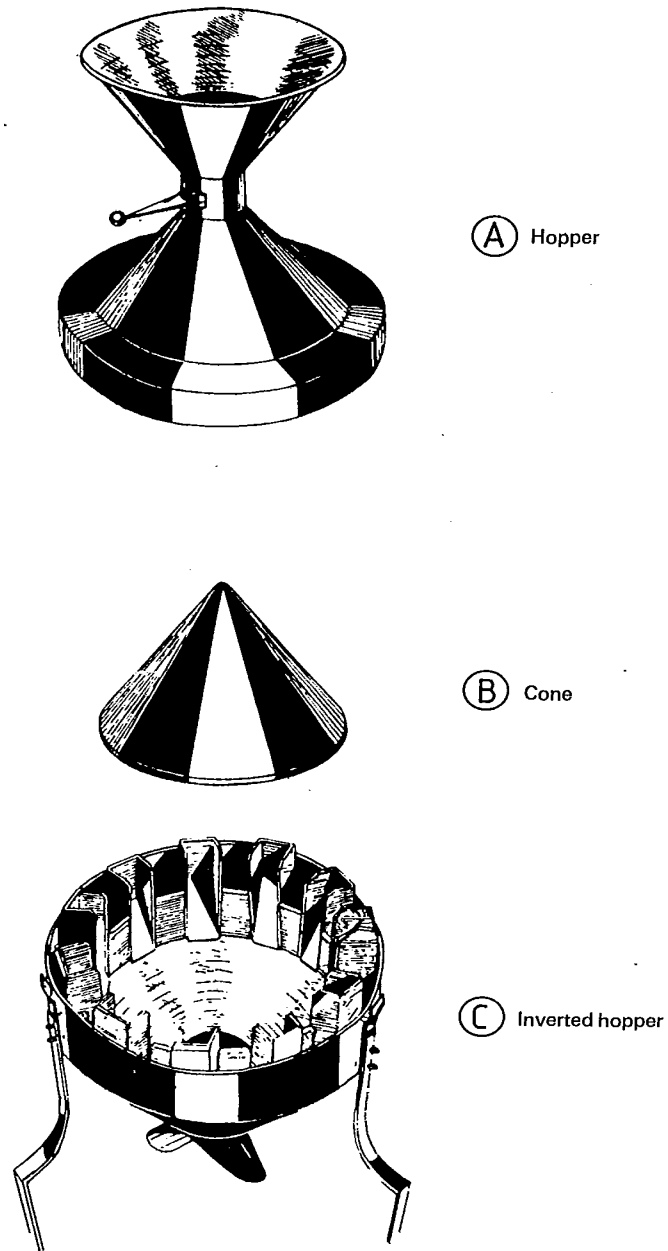

Figure 15a — Exploded view of a typical conical divider (see ISO 607)

Dimensions in millimetres

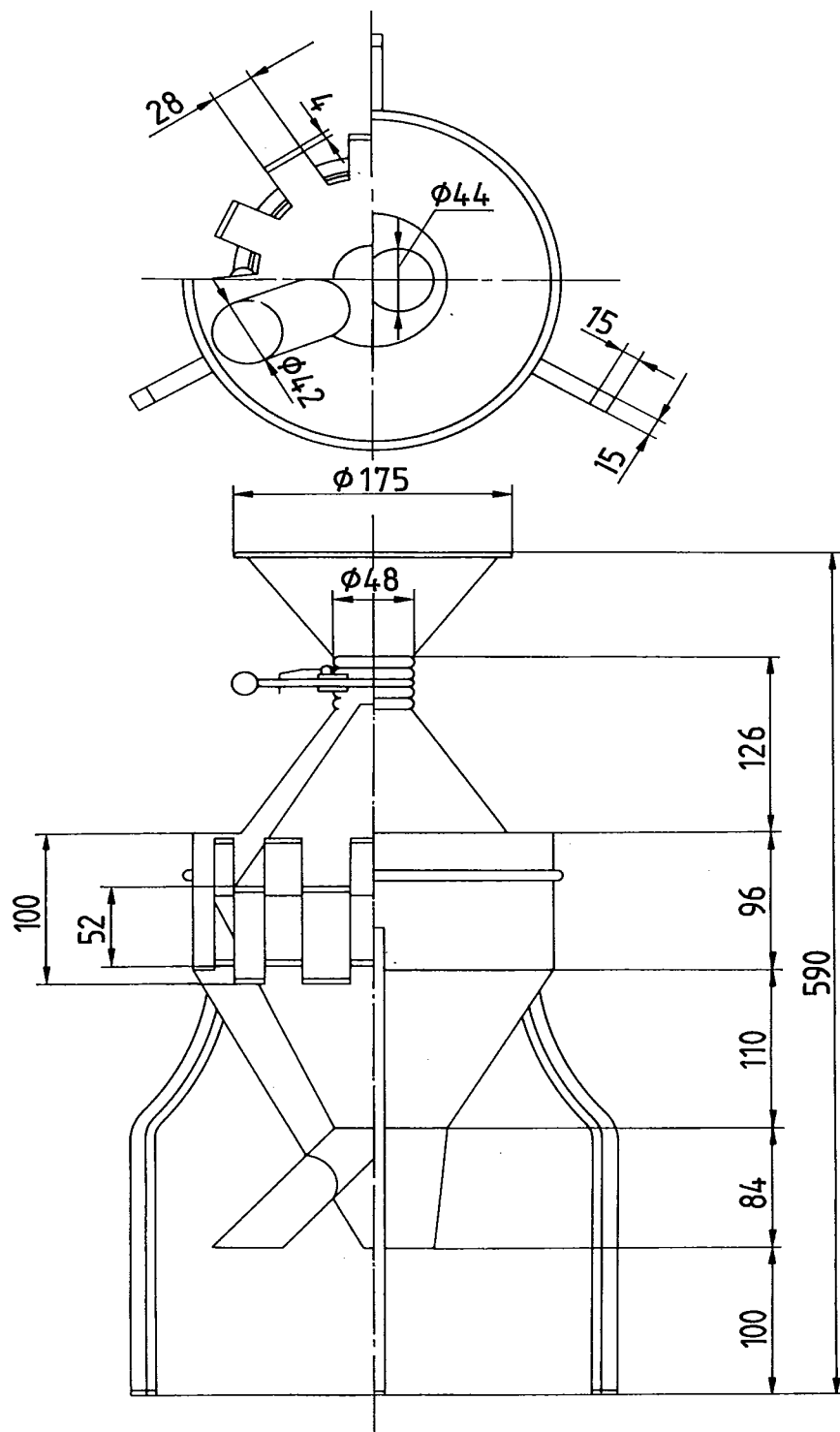

Figure 15b — Diagram of a typical conical divider (see ISO 607)

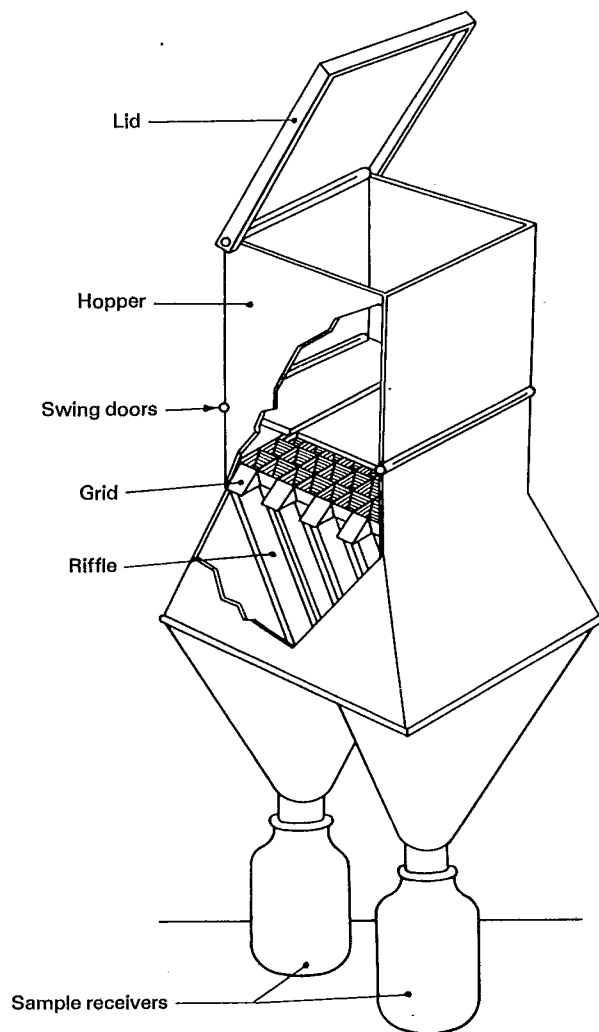

Figure 16 — Grid-type sample divider (see 4.1.3)

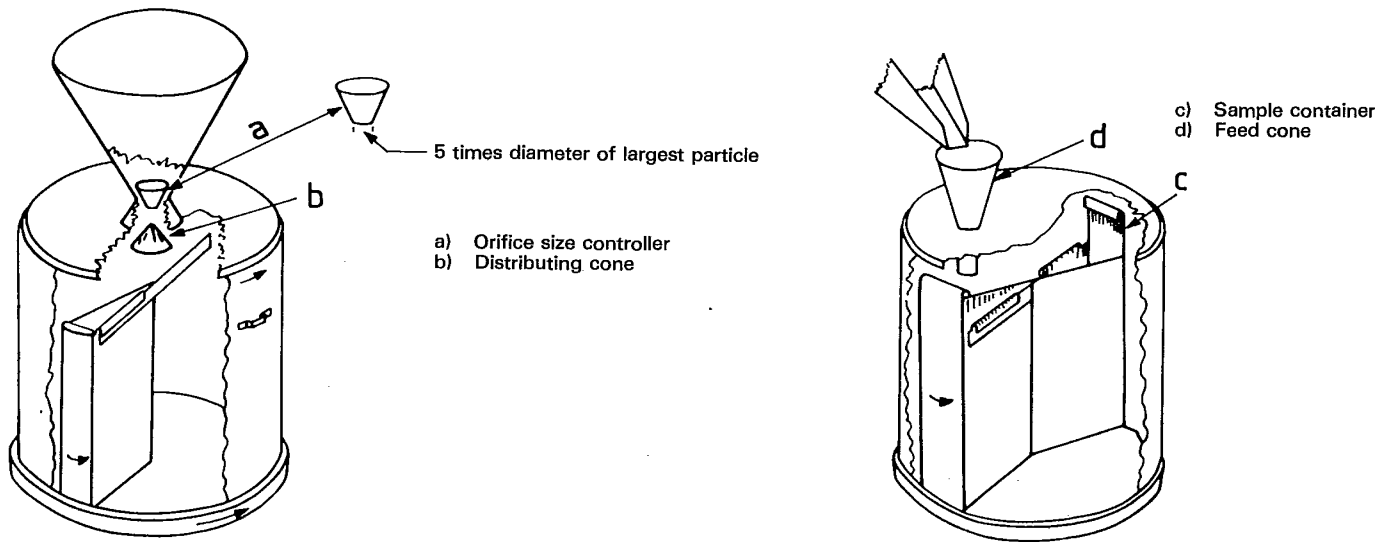

Figure 17 — Rotary sample dividers (see 4.1.3)

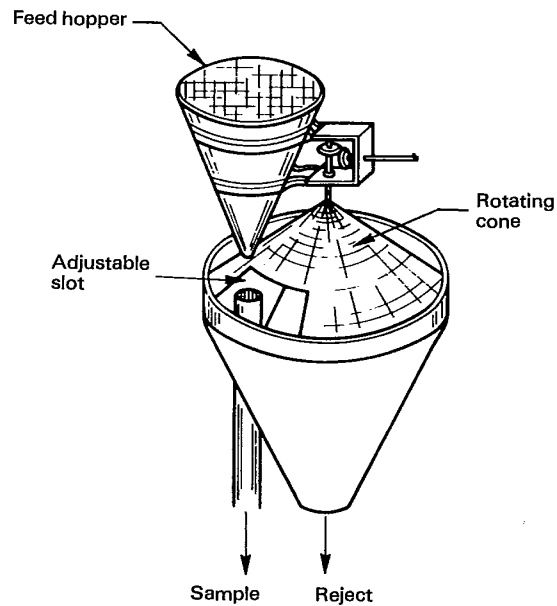

Figure 18 — Double-cone sample divider (see 4.1.3)

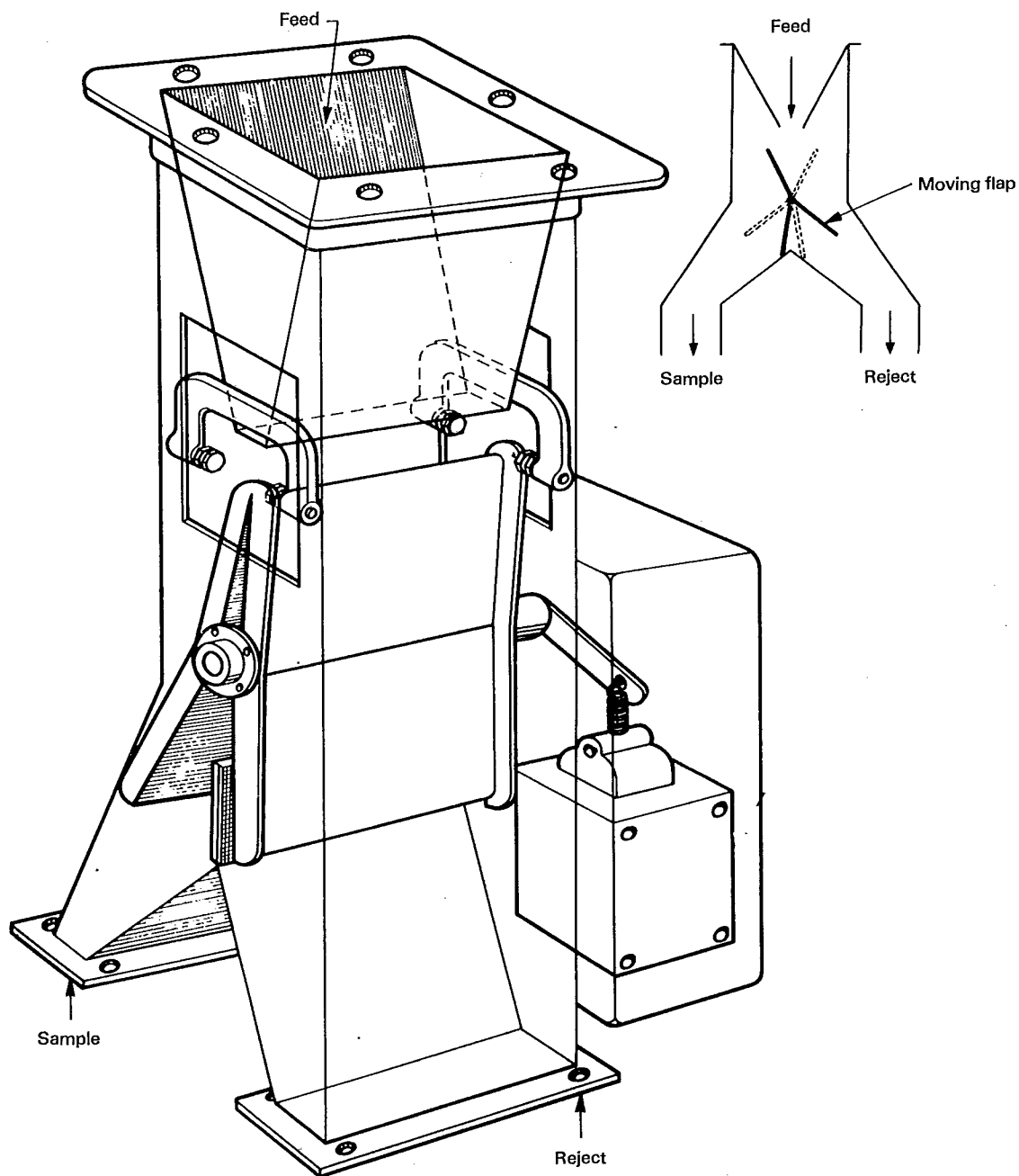

Figure 19 — Moving-flap sample divider (see 4.1.3)

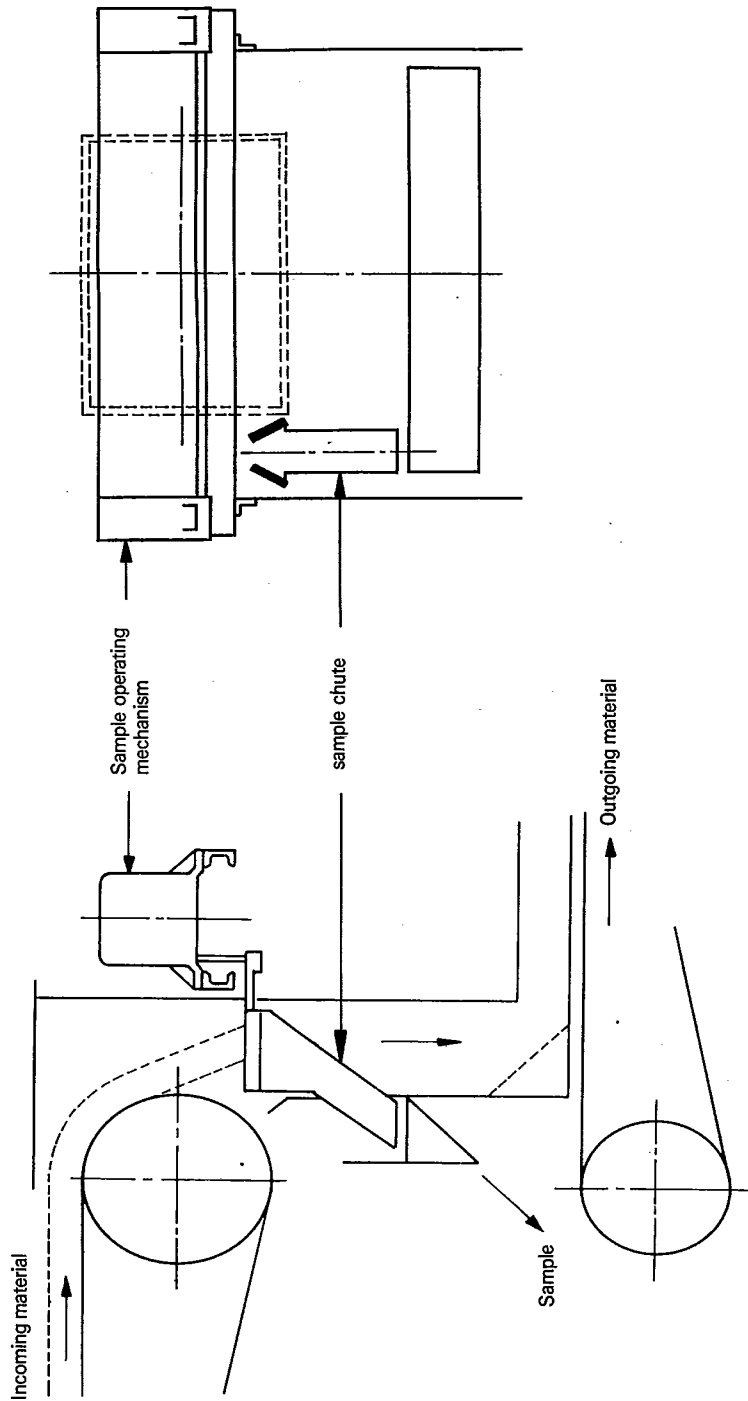

Figure 20 — Intermittent automatic sampler (see 4.1.4)

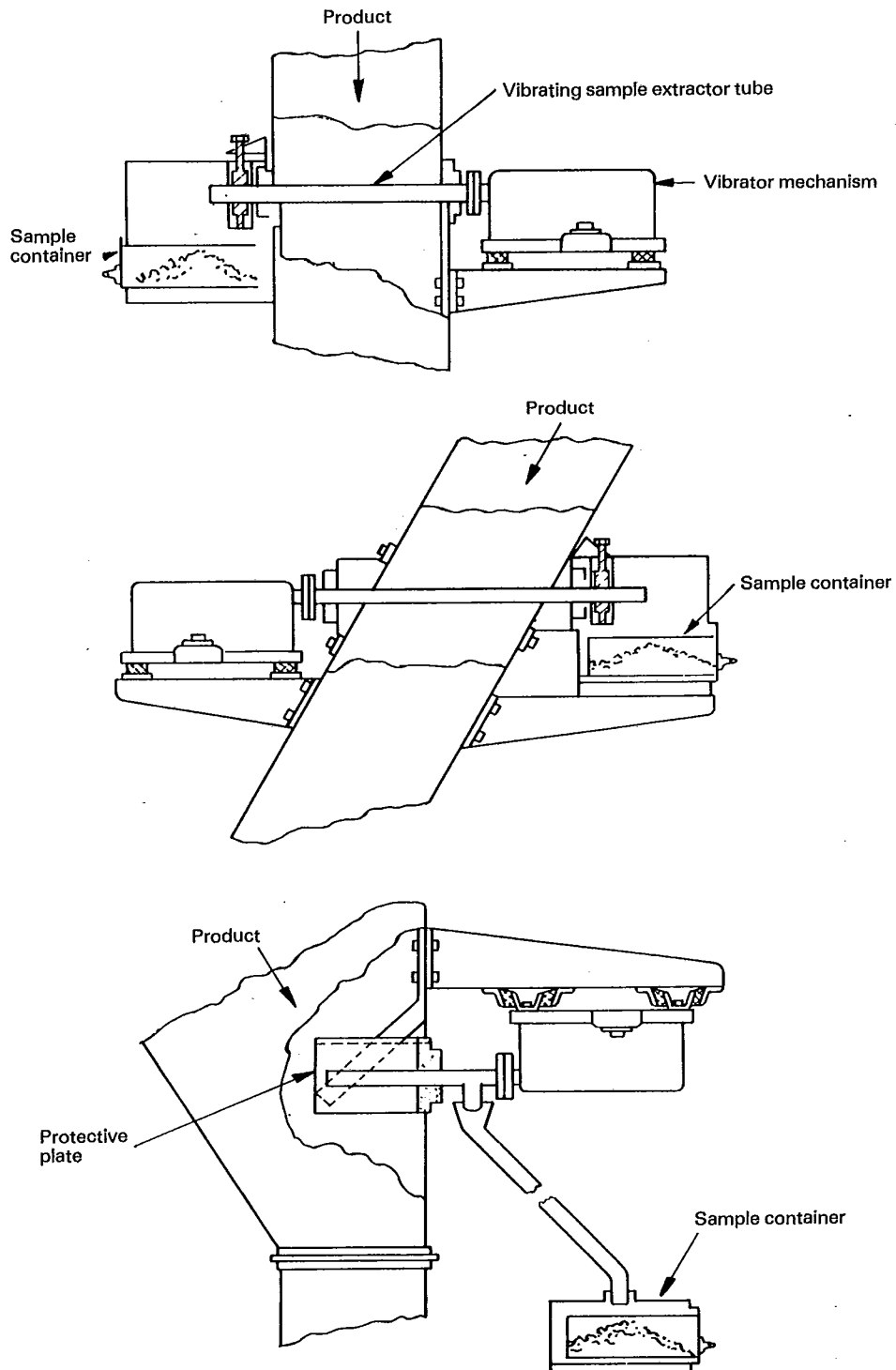

Figure 21 — Continuous automatic samplers (see 4.1.4)

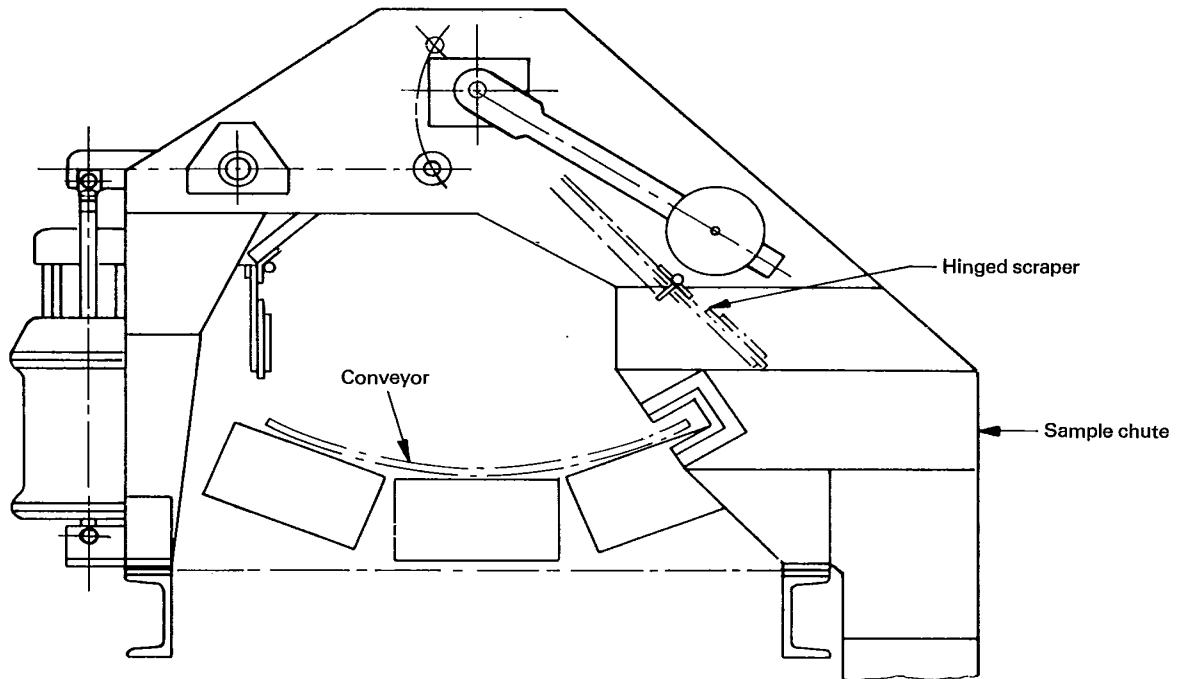

Figure 22 — Automatic sampler for belt conveyor (see 4.1.4)

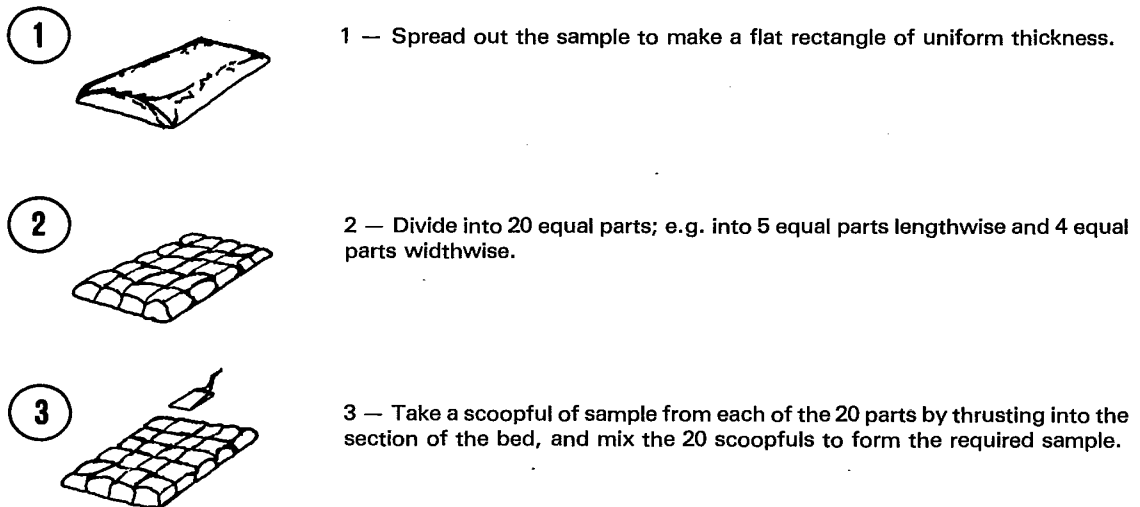

Figure 23 — Alternate division procedure (see 5.6.4.2)

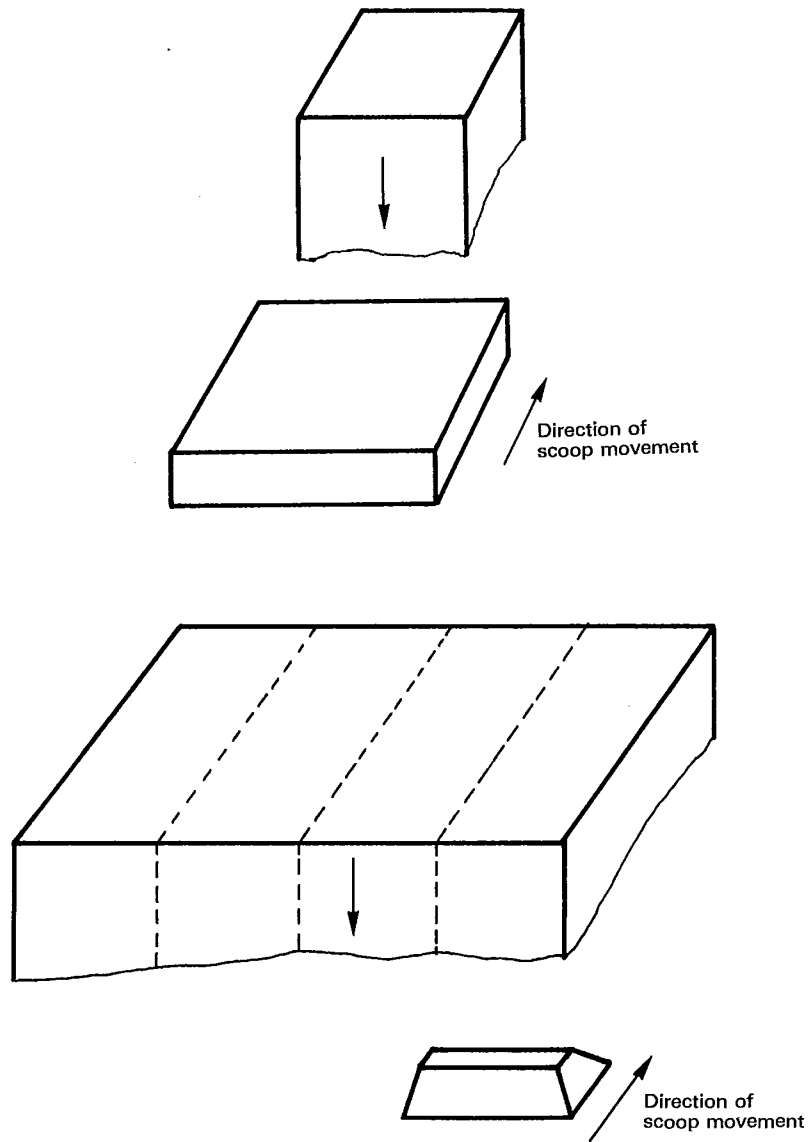

Figure 24 — Cross-sectional samples of a falling stream (see 5.6.4.3)

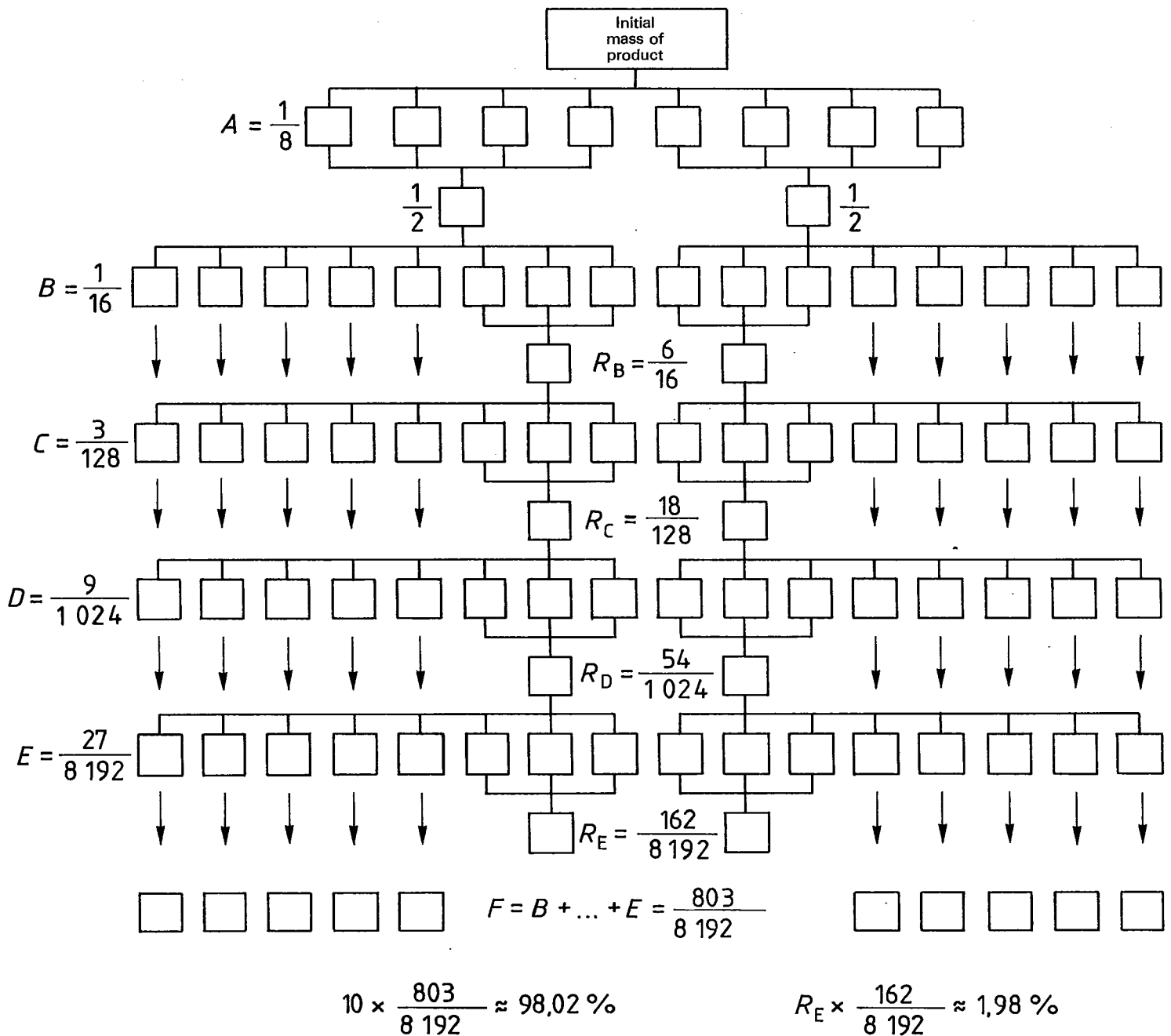

Figure 25 — Obtaining 10 equal representative fractions with a divider into 8 (see 5.6.6.1)

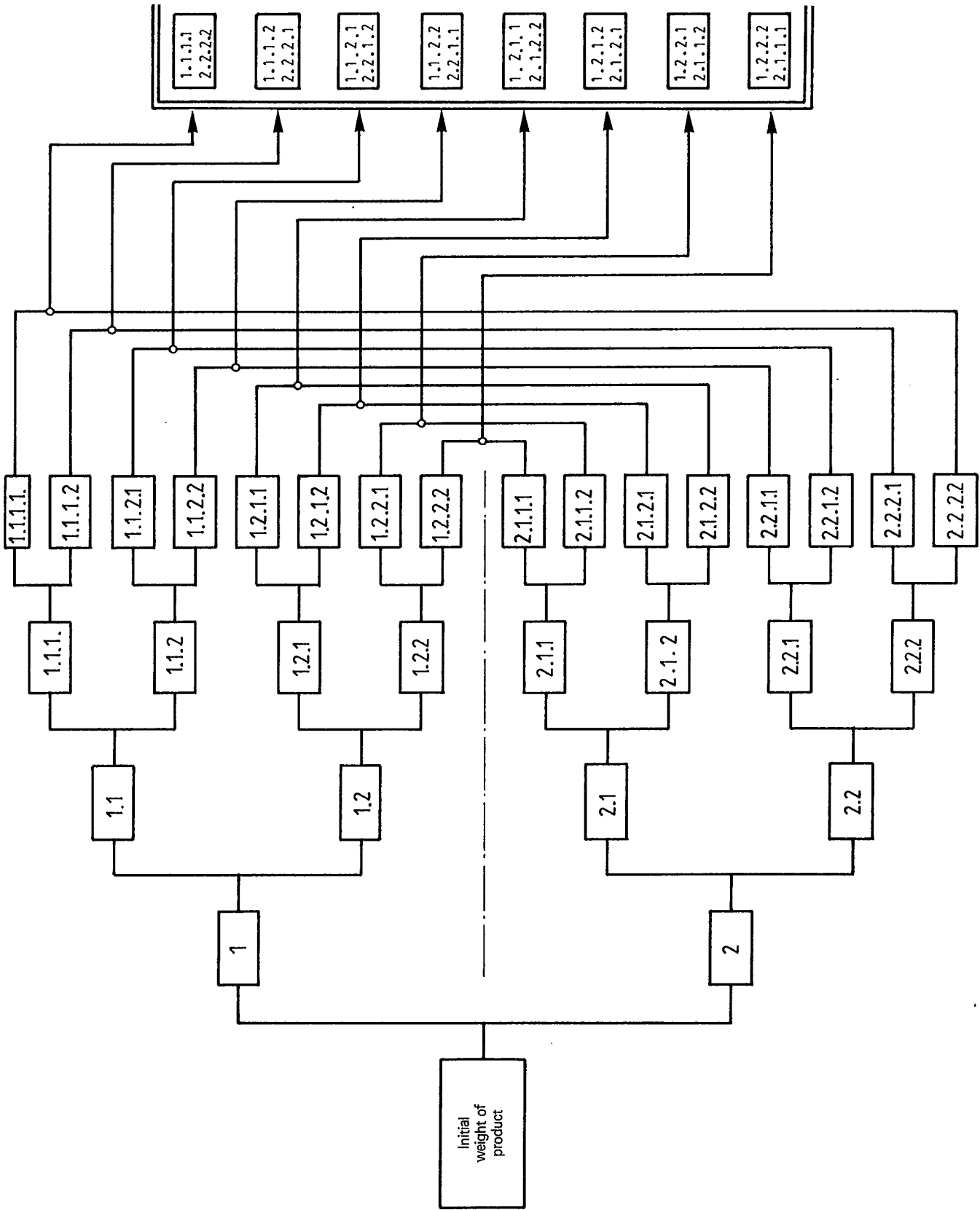

Figure 26 — Division in 8 equal representative fractions with a divider into 2 (see 5.6.6.2)

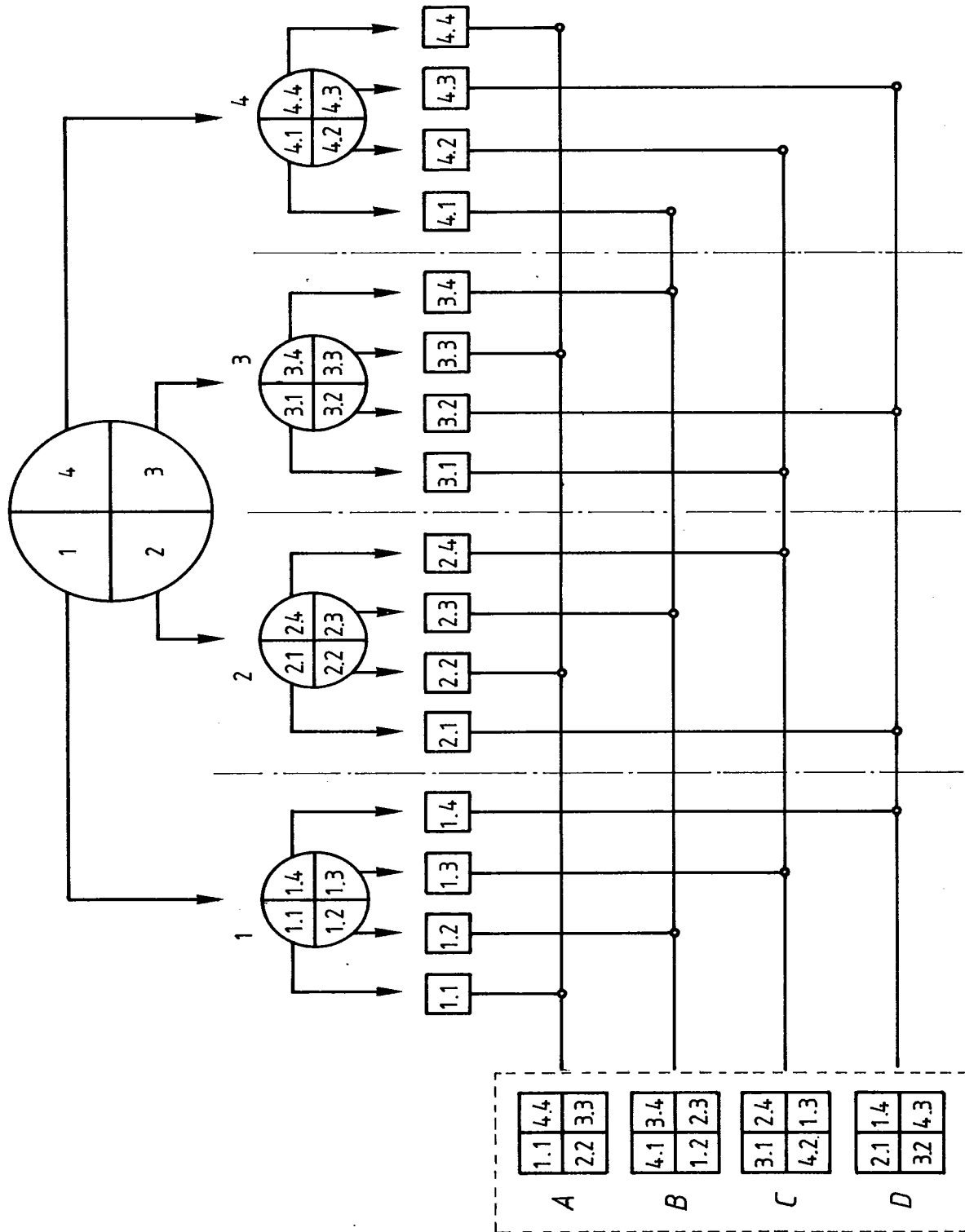

Figure 27 — Obtaining representative fractions by sampling by quartering (see 5.6.7)