

INTERNATIONAL
STANDARD

ISO
8049

Second edition
2016-06-01

Ferronickel shot — Sampling for analysis

Ferro-nickel en grenailles — Échantillonnage pour analyse



Reference number
ISO 8049:2016(E)

© ISO 2016



COPYRIGHT PROTECTED DOCUMENT

© ISO 2016, Published in Switzerland

All rights reserved. Unless otherwise specified, no part of this publication may be reproduced or utilized otherwise in any form or by any means, electronic or mechanical, including photocopying, or posting on the internet or an intranet, without prior written permission. Permission can be requested from either ISO at the address below or ISO's member body in the country of the requester.

ISO copyright office
Ch. de Blandonnet 8 • CP 401
CH-1214 Vernier, Geneva, Switzerland
Tel. +41 22 749 01 11
Fax +41 22 749 09 47
copyright@iso.org
www.iso.org

Contents

Page

Foreword	iv
1 Scope	1
2 Normative references	1
3 Form and packaging of product	1
4 Principle	1
5 Taking of the primary sample and then of the intermediate sample	2
5.1 Blended lots	2
5.1.1 Bulk sampling in the case of a suitable system for taking the primary sample	2
5.1.2 Sampling of bulk material when no adequate primary sampling system is available	3
5.1.3 Sampling of a drum-packed lot	3
5.1.4 Sampling of a container-packed lot	3
5.2 Particular case of a lot made up of one single heat	5
6 Treatment of the intermediate sample and taking of the secondary sample	5
6.1 General	5
6.2 Blended lot	5
6.3 Lot made up of a single heat	5
7 Remelting of the secondary sample	5
8 Use of small ingots (secondary increments)	6
Annex A (informative) Justification of the number of primary and secondary increments	8
Annex B (informative) Methods for taking a sample of size N in a supply of M items	17
Annex C (informative) Technical conditions for drilling and milling	21
Bibliography	29

Foreword

ISO (the International Organization for Standardization) is a worldwide federation of national standards bodies (ISO member bodies). The work of preparing International Standards is normally carried out through ISO technical committees. Each member body interested in a subject for which a technical committee has been established has the right to be represented on that committee. International organizations, governmental and non-governmental, in liaison with ISO, also take part in the work. ISO collaborates closely with the International Electrotechnical Commission (IEC) on all matters of electrotechnical standardization.

The procedures used to develop this document and those intended for its further maintenance are described in the ISO/IEC Directives, Part 1. In particular the different approval criteria needed for the different types of ISO documents should be noted. This document was drafted in accordance with the editorial rules of the ISO/IEC Directives, Part 2 (see www.iso.org/directives).

Attention is drawn to the possibility that some of the elements of this document may be the subject of patent rights. ISO shall not be held responsible for identifying any or all such patent rights. Details of any patent rights identified during the development of the document will be in the Introduction and/or on the ISO list of patent declarations received (see www.iso.org/patents).

Any trade name used in this document is information given for the convenience of users and does not constitute an endorsement.

For an explanation on the meaning of ISO specific terms and expressions related to conformity assessment, as well as information about ISO's adherence to the WTO principles in the Technical Barriers to Trade (TBT) see the following URL: [Foreword - Supplementary information](#)

The committee responsible for this document is ISO/TC 155, *Nickel and nickel alloys*.

This second edition cancels and replaces the first edition (ISO 8049:1988). The following change has been made: [5.1.4](#) has been added.

Ferronickel shot — Sampling for analysis

1 Scope

This International Standard defines a method of sampling for analysis of ferronickel lots in the form of shot as specified in ISO 6501 in those cases where lots are constituted either heat by heat or by taking from blended stock.

The purpose is to determine the contents of the various elements

- either from slugs by physical analysis methods (such as X-ray fluorescence or emission spectral analysis), or
- from chips by dry methods (carbon, sulfur) or chemical analysis (other elements).

2 Normative references

The following documents, in whole or in part, are normatively referenced in this document and are indispensable for its application. For dated references, only the edition cited applies. For undated references, the latest edition of the referenced document (including any amendments) applies.

ISO 513:2012, *Classification and application of hard cutting materials for metal removal with defined cutting edges — Designation of the main groups and groups of application*

3 Form and packaging of product

Grain size: between 3 mm and 50 mm.

Lot tonnage: equal to or greater than 5 t.

In the case of lots taken from blended stock, the nickel content range k to $(k + n)$ % of the blended heats shall be chosen as follows:

- $15 \leq k \leq 59$;
- $1 \leq n \leq 5$;
- $16 \leq k + n \leq 60$.

NOTE The case of non-blended lots (case $n \leq 1$) is not dealt with in this International Standard.

The ferronickel shot is generally delivered in bulk form in units which may be trucks, containers, or railroad cars, of which the contained masses normally range from 5 t to 30 t, although in the case of railroad cars, loads may have masses up to 60 t.

This type of ferronickel can also be delivered drum-packed (the contained mass of which may be 250 kg).

4 Principle

In a single heat, intergrain homogeneity is practically ensured. It is therefore very easy to obtain a representative “primary sample” from a small number of “primary increments”.

In the case of a blended lot composed of several heats, a greater number of primary increments, N_p , should be taken, but the whole still constitutes the primary sample.

After blending and mass division of the primary sample, an “intermediate sample” is obtained having a reasonable mass for laboratory treatment. The treatment of the intermediate sample gives a “secondary sample”, which may be divided in N_s “secondary increments” not exceeding a mass of 1 kg individually.

Each secondary increment is then remelted under appropriate conditions so that no variation in composition can be observed and that N_s homogeneous small ingots be obtained (within-small-ingot homogeneity).

NOTE It is generally accepted that 1 kg is the maximum mass which can be accommodated in a laboratory furnace for re-casting under the required conditions. According to the grain size distribution of shot, it is often necessary for the secondary sample to exceed 1 kg in order to be representative. Hence, the necessity of melting several small ingots. See the statistical justification in [Annex A](#).

The small ingots are then either used for physico-chemical analysis or machined into chips for chemical analysis. (This procedure is summed up in [Figure A.1](#).)

5 Taking of the primary sample and then of the intermediate sample

5.1 Blended lots

5.1.1 Bulk sampling in the case of a suitable system for taking the primary sample

This can be performed, for example, by emptying the shot into a bin with reclaim by belt conveyor. From the conveyor discharge, two possibilities are as follows:

- to have a true sampling system respecting the rules of the art for sampling of particulate material (such as a cross stream sampler);
- to take increments at regularly spaced intervals, using a power shovel with a dipper intercepting the shot stream in a representative manner.

The mass of each primary increment shall be, in this case, not less than 20 kg, and is generally between 20 kg and 50 kg.

The number of primary increments, N_p , to be selected is shown in [Table 1](#).

Table 1 — Minimum number of primary increments to be selected

Sample	Tonnage	Range of nickel contents, n				
		$n < 1$	$1 \leq n < 2$	$2 \leq n < 3$	$3 \leq n < 4$	$4 \leq n \leq 5$
Numbers of primary increments N_p	5 to 50	5	10	15	20	30
	50 to 200	7	12	17	22	35
	200 to 500	10	15	20	25	40
	500 to 2 500	15	20	25	30	45
Number of secondary increments N_s^a		1	2	3	4	5

^a This indicates the number of small ingots to be remelted in the hypothesis of 1 kg per small ingot. (If the maximum mass which can be remelted is $1/x$ kg, the number of small ingots to be remelted is $x \times N_s$.)

The primary sample shall then be mass-divided into smaller units, in order to obtain an intermediate sample having a mass which can reasonably be sent to the laboratory for further preparation, 20 kg to 50 kg, say.

This can be accomplished with automatic mass dividers (such as rotary dividers) of suitable size with respect to the particle size of the product being handled.

Failing such equipment, the division can be made by alternate shovelling from the primary sample stockpile. As a precaution against material spill during shovelling, it is recommended that a scoop or coal-miner's-type shovel be used.

For example, every fifth shovelful or less would be taken and this division would be repeated a sufficient number of times to obtain the desired sample mass of 20 kg to 50 kg.

5.1.2 Sampling of bulk material when no adequate primary sampling system is available

In this case, hand sampling shall be performed by alternate shovelling on each unit to be checked (truck, railroad car, container, etc.). The number of units to be checked is the number N_p in [Table 1](#) or the total number of units if it is less than N_p . For this purpose, the rules for random sampling given in [Annex B](#) may be applied.

EXAMPLE When unloading a 20 t truck on to the ground, sampling could proceed as follows:

- shovel the 20 t, setting aside every fifth shovelful;
- from the 4 t obtained, set aside every fifth shovelful;
- from the 800 kg obtained, set aside every fifth shovelful;
- from the 160 kg obtained, set aside every fifth shovelful;
- send the 32 kg obtained to the laboratory.

In this example, an intermediate sample is obtained for the checked unit.

If more than one unit is checked in the same lot, intermediate samples in each unit can be blended and mass division carried out again until an intermediate sample representative of the lot is obtained. In this case, the intermediate sample mass can be reduced to 10 kg to 20 kg.

5.1.3 Sampling of a drum-packed lot

The number of drums from which increments should be taken is the number N_p in [Table 1](#) or the total number of drums if this is less than N_p .

NOTE In general, drum-packaging is used for low-tonnage lots. The first line of the table is therefore applicable in most cases.

A minimum of 1 kg of shot or more, if required, per selected drum is taken to obtain a mass in excess of 20 kg, generally between 20 kg and 50 kg.

If the contents of each drum are assumed to be homogeneous, the sample may be taken from the top of the drum. If not, the drums shall be emptied and the sample taken by alternate shovelling.

5.1.4 Sampling of a container-packed lot

5.1.4.1 Principle

This sampling method is applicable only for the determination of the nickel content (Ni).

The aim of this proposal is to simplify the sampling mode of a ferronickel delivery at customer site. Indeed generally,

- the end user does not have the appropriate means to proceed rigorously with this standard to sample the product, and
- when the end user gets the analytical results on the delivery, the lot is already partially or totally consumed, and consequently a further contradictory sampling is not possible.

This way of doing can be only used in the case of a blended lot which has been constituted with several heats (presenting different chemical analysis) stored in a big stand. When the stand is full, the homogenization of the stand shall be carried out and the parameters of exactness and reliability of the stand should be determined.

The exactness is the difference in Ni content between the first and the last heat.

The reliability is the biggest difference in Ni content between two heats.

The values of those both parameters will determine the way to go with the customer lot analysis:

- under certain values the customer lot analysis will be the one of the stand;
- above these values the customer lot will be sampled during the containers loading and the customer lot analysis will be the one of the representative sample of the customer lot.

5.1.4.2 Sampling method

If the conditions described previously are fulfilled for the stand, only one container (taken at random) of the customer lot can be sampled.

EXAMPLE To sample a 20 t container, sampling could proceed as follows:

- take a minimum of 16 portions of ~5 kg shots, largely scattered in the metal mass (into the container or spread on a clean ground), 8 at the surface and 8 inside the mass, to obtain a sample of approximately 80 kg;
- homogenize this sample using a suitable riffle divider (D62 is minimum) or by alternate shovelling;
- make successive divisions using a suitable riffle divider or by alternate shovelling to finally obtain two twin samples of ~5 kg to be packed in sealed plastic bags with lot reference labelling.
- one sample is provided to the laboratory for preparation and analysis, the second is kept for a possible other control.

Ni content is then determined with the appropriate analytical method and compared with the Ni content of the stand as follows:

- If $x - 3' \sigma_s < X_c < x + 3' \sigma_s$, the customer lot is in accordance with the supplier analysis certificate;
- If X_c is out of the interval, the customer lot is not in accordance with the supplier analysis certificate

where

X_c is the Ni content (obtained by the customer at lot reception) in the sampled container;

x is the Ni content of the supplier analysis certificate;

σ_s is the calculated standard deviation of Ni contents in the containers;

where

$$\sigma_s = \sigma_e (1 - \rho_h)$$

where

σ_e is the calculated standard deviation of Ni content in the heats constituting the stand;

ρ_h is the homogenization rate of the stand (determined by the supplier).

5.2 Particular case of a lot made up of one single heat

As inter-grain homogeneity is ensured, it is sufficient to take the minimum quantity of material for small ingot remelting (1 kg for example).

To have more adequate guarantee, a small number of primary samples, for example, 3 to 5, can be taken (either by bulk sampling or sampling from drums), then blended and mass divided in order to obtain an intermediate sample of 5 kg to 10 kg.

If the lot is not assumed to be made up of a single heat, one of the procedures described in [5.1](#) shall be applied.

6 Treatment of the intermediate sample and taking of the secondary sample

6.1 General

This is generally carried out in the laboratory sampling shop.

6.2 Blended lot

The intermediate sample is blended, then mass-divided preferably using a riffle divider of appropriate dimensions or failing this, by alternate shovelling, until a mass equal to or slightly exceeding the mass, in kilograms, in the last line of [Table 1](#) is obtained. In the table, N_s is the number of small ingots to be remelted when 1 kg of material can be melted in one operation. (If melting is achieved by masses of $1/x$ kg, the number of small ingots to be remelted is $x \times N_s$.)

The colander width shall be at least three times the mean diameter of the largest shot.

The mass defined by the rule above is the mass to be remelted and to be used for representative analysis. If a sampling reject or second unmelted secondary sample is to be kept, the corresponding quantity of material shall be set aside at the time of mass divisions.

6.3 Lot made up of a single heat

To be representative, a small ingot having a mass of 250 g to 1 000 g shall be obtained. This is obtained by blending and mass division of the intermediate sample made in accordance with [5.2](#) until the mass required for remelting is obtained.

7 Remelting of the secondary sample

Remelting shall be performed in conditions such that no variation in content (of either Ni or the impurities to be checked) occurs either during melting or casting of the final sample (slugs, rondelles, or small ingots).

In practice, the melting shall be done by induction heating in order to be carried out rapidly, it generally requires argon protection. The melted sample can be cooled and solidified in the melting pot itself, provided that argon protection is provided. However, it is much better to cast after melting by centrifuging. This ensures the following:

- an excellent homogeneity of the sample produced as a result of mixing the molten metal during its injection into the mould;
- a uniform crystalline structure which fosters a good repeatability of the measurements for physical analysis methods. The argon protection should preferably be maintained during centrifuging.

It is recommended that a reagent (such as aluminium chips in a proportion of 1 g/kg to 2 g/kg) be introduced to kill the shot to be remelted. Naturally, the dilution undergone by the sample can be taken into account to correct the nickel content found during final analysis.

8 Use of small ingots (secondary increments)

8.1 The small ingots produced are truncated near their base to obtain a slice having a thickness of some 15 mm to 20 mm.

The slices obtained can be used for physical analysis and the average value of the analyses is calculated.

8.2 It is also possible to take chips by drilling or milling on the remaining parts of the small ingots. Chips coming from all the small ingots are conditioned for analysis by dry methods (sulfur and carbon) or chemical analysis (for the other elements).

8.2.1 Precautions for chip machining

Machining (and preferably milling) shall be carried out in such a way that chips cannot be contaminated (either by cutting tool wear or by dust or grease). In particular, the work shall be carried out under dry conditions.

For the detailed technical conditions of machining, see [Annex C](#).

Some ferronickel types are very hard, hence, the need to select appropriate cutting tools and cutting conditions with great care.

Machining will generally be easier if the small ingot is previously annealed.

8.2.2 Treatment of chips

8.2.2.1 Washing

When surface contamination of chips (by lubricants, dust, etc., inevitably present when working with machine tools) is feared, it is strongly recommended that the chips be washed twice in pure acetone (or once in pure acetone and once in pure ether).

The solvent is drained off. Residual solvent is then evaporated in the air and the sample is dried for a minimum of 0,5 h in an oven maintained at 100 °C to 110 °C.

The use of pure organic solvents and their utmost removal is required for later determination of carbon and sulfur with automatic devices according to dry instrumental techniques.

8.2.2.2 Crushing

If chips come from a single small ingot, due to the fact that cast small ingots are very homogeneous, it is not necessary to crush the chips.

NOTE This is all the more valid the finer the chips. Millings are finer than drillings.

If several small ingots have been cast it is useful, when possible, to crush the chips in order to achieve homogeneity between the chips from various small ingots.

In practice, crushability depends on the following:

- the nickel content, if it exceeds 35 %, the alloy becomes ductile and is difficult to crush;
- the impurity contents (above all carbon): high-carbon ferronickels can be crushed much finer than low-carbon ferronickels.

In the case of crushable ferronickels, a suitable crusher shall be used which does not introduce contamination with iron. Vibration mill laboratory crushers used for a duration of 10 s to 30 s are suitable. It is desirable that the crushing container be of tungsten carbide or, if this is not possible, of special anti-wear steel (ball-type or bar-type crushers are not permissible).

In the case of ferronickels having nickel contents less than 35 %, 30 s crushing gives such fine material that almost all can be considered as undersize in case of sieving:

- on a sieve having a 2,5 mm aperture size (8 mesh), for low-carbon ferronickel (LC);
- on a sieve having a 0,8 mm aperture size (20 mesh) for medium-carbon ferronickels (MC) and high-carbon ferronickels (HC).

8.2.2.3 Homogenization and bottling

When the chips derive from several small ingots, it is necessary to achieve homogenization (using a mechanical homogenizer or repeated alternative shovelling, or several passes through a riffle divider keeping all the material, etc.).

The sample shall be subdivided in several portions using a riffle divider or a sample distributor. The number of fractions will depend on the required number of test samples for analysis to be kept by the interested parties.

The minimum distribution shall be the following:

- one for the purchaser,
- one for the vendor,
- one for the referee,
- one reserved.

For low-carbon ferronickels (LC), ail handling operations shall be carried out so that no carbon contamination can occur (no contact with paper, cardboard, rubber, cork, or plastics; metallic materials and aluminium foils can be used).

The same care shall be exercised for bottling.

For medium-carbon ferronickels (MC) and high-carbon ferronickels (HC), samples can be stored in bottles of, for example, glass or aluminium, or in thick, heavy-quality polyethylene bags.

Annex A (informative)

Justification of the number of primary and secondary increments

A.1 General

The reasoning below applies to blended lots.

The definition of the product is given in [Clause 3](#).

The adopted procedure is derived from the following preliminary considerations:

- a) excellent homogeneity within a granulated heat. No content variation is detected (for nickel and the various impurities: carbon, cobalt, chromium, sulfur, silicon) either among granules of the same particle size range or among the various particle size ranges within the same heat;
- b) particle size distributions may vary considerably from one heat to another in a blended lot;
- c) it is possible to remelt ferronickel shot under argon without varying the content of nickel, cobalt, chromium, silicon, sulfur. However, slight reductions in carbon contents have been observed.

In practice, the maximum known capacity of remelting furnaces is 1 kg and the numerical values of N_s in [Table 1](#) have been chosen on this basis.

The study has been carried out mainly on nickel contents, which are the figures on which the greatest accuracy is sought.

A.2 Sampling scheme

The general principle adopted is summed up in [Figure A.1](#).

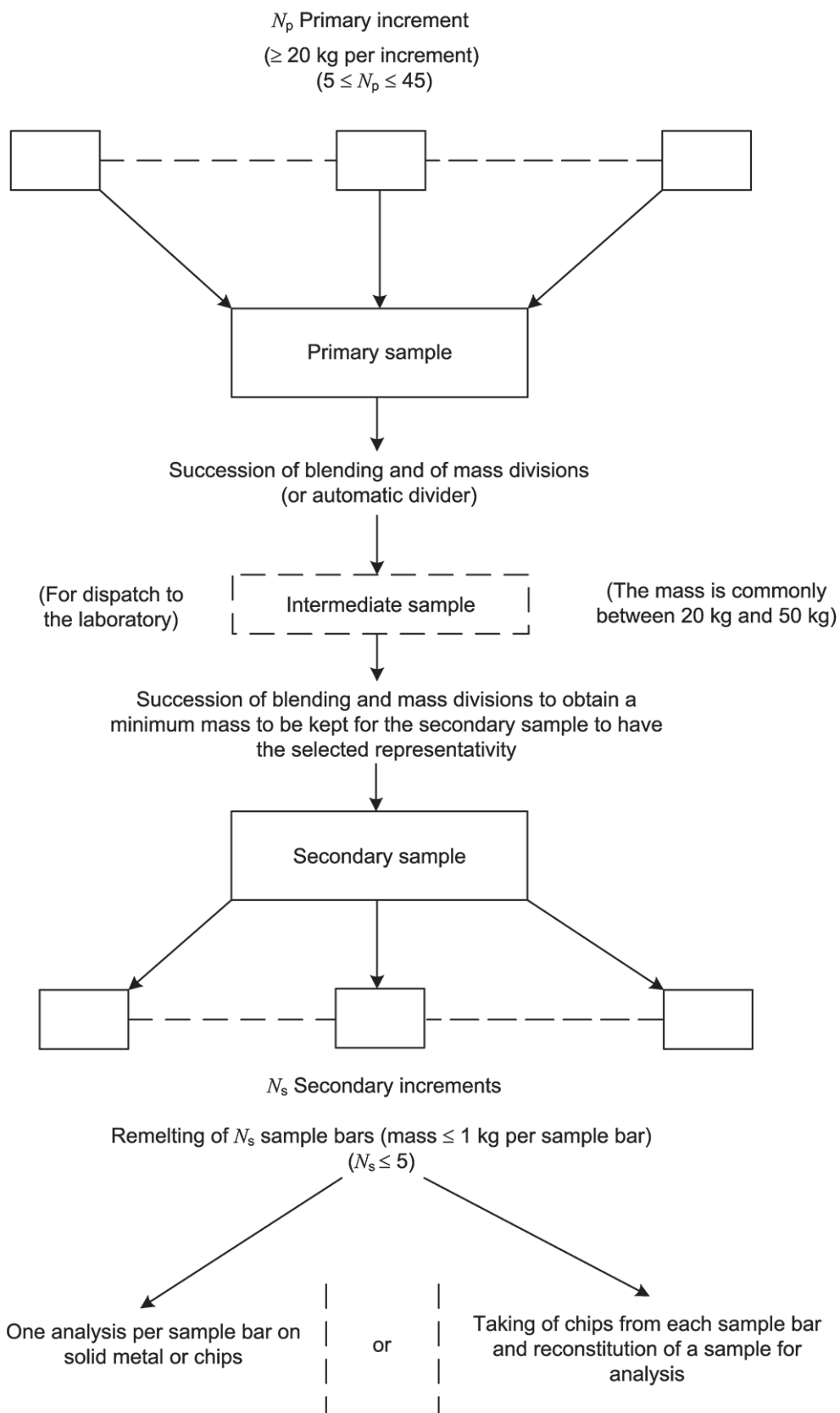

Figure A.1 — General scheme of increments

The following notation is used:

N_p is the number of primary increments;

V_p is the primary variance estimating the scatter of nickel contents among primary increments.

This variance therefore gives an estimate of the slight heterogeneity which may be observed in the whole lot when it is discharged at the purchaser's.

This quantity is by nature a variance of integration (zero if homogeneity is perfect among primary increments). It is generally not computable from a theoretical scheme. Only empirical observations can be made when the lots are discharged.

N_s is the number of secondary increments. This is the number of remelted small ingots;

V_s is the secondary variance estimating the scatter of nickel contents among secondary increments (mass ≤ 1 kg).

The fact that the material is made up of separate shot particles and that the heats selected within a defined range of nickel contents are blended means that a minimum mass of blended material shall be kept for the secondary sample to be representative.

This quantity is by nature a fundamental variance [which always exists in any fragmented material undergoing content variations from fragments to fragments, even if homogenization (or blending) is perfect].

There are mathematical models for calculating this quantity. Their application to ferronickel lots generally implies keeping a mass in excess of 1 kg. This is the main reason why several small ingots are remelted and why N_s and V_s are to be evaluated.

V_e is the sampling variance.

We have:

$$V_e = \frac{V_p}{N_p} + \frac{V_s}{N_s} \quad (\text{A.1})$$

NOTE The intermediate sample is not taken into consideration in the procedure principle. It is only one sample among all the others handled during blending and mass-division operations. It is to be selected with a reasonable mass for transportation between the primary sampling location at the works and the laboratory.

If one analysis is carried out per remelted sample ingot:

$$V_{Ni} = \frac{V_p}{N_p} + \frac{V_s}{N_s} + \frac{V_r}{N_s} + V_A + V_L \quad (\text{A.2})$$

where

V_{Ni} is the variance of nickel content over all "sampling and analysis" operations when several laboratories are compared;

V_r is the variance of analytical repeatability;

V_A is the variance of inter-analyst fluctuation (analytical);

V_L is the variance of inter-laboratory fluctuation (analytical).

NOTE For the detailed significance of V_r , V_A , V_L , see ISO 6352:1985, Annex B.

A.3 Estimate of primary variance

Observations have been made by some producers either at dispatch from the manufacturing plant or at the time of delivery at the purchaser's.

Even in the case $n = 5$ (maximum range of nickel content), very low values of V_p have always been observed.

The value $V_p = 0,01$ has been retained for $n = 5$, which is noticeably in excess of any collected concrete observations. It can therefore be considered as a safe value.

Moreover, it has been assumed that the upper limit adopted for V_p could be reduced when n was reduced.

Again a slight diminution of the value of $S_p = \sqrt{V_p}$ has been admitted by prudence, according to [Table A.1](#).

Table A.1 — Variation of S_p

n	$S_p = \sqrt{V_p}$	V_p
1	0,06	0,003 6
2	0,07	0,004 9
3	0,08	0,006 4
4	0,09	0,008 1
5	0,10	0,010 0

A.4 Estimate of secondary variance

A.4.1 General

The main conclusions drawn from a mathematical model for the estimation of this fundamental variance are given in [A.4.2](#) to [A.4.4](#).

A.4.2 Blended heats

The fact that heats with different particle size ranges and nickel content are blended has no effect on the value of the fundamental variance if no correlation is found between the nickel content and the mass of each shot particle.

A.4.3 Estimation of the between-heats variance, V_c

This is the variance which estimates the variations due only to the difference in nickel contents between heats (without taking into account the granular nature of the material).

The variance is of the form:

$$V_c = \frac{(n + 2\varepsilon)^2}{\alpha} \times \frac{M - N}{M - 1} \quad (\text{A.3})$$

where

ε is the numerical value expressing the uncertainty in the determination of the nickel content of a heat, which means that the range defined by k to $(k + n)$ % as planned to constitute be blended batch may be extended in practice from $(k - \varepsilon)$ to $(k + n + \varepsilon)$ %. The theoretical range is n . The practical range is $n + 2\varepsilon$;

M is the total number of shot particles in the lot;

N is the number of shot particles in the primary sample;

α is the coefficient, the numerical values of which have been calculated under three hypothetical conditions of nickel content distribution within the range, as follows:

- hypothesis 1 (most unfavourable case): Half of the heats are at the lower limit $(k - \varepsilon)$ % and the other half at the upper limit $(k + n + \varepsilon)$ %: $\alpha = 4$;
- hypothesis 2 (less unfavourable case): The contents, heat after heat, are uniformly distributed between the two limits: $\alpha = 12$;
- hypothesis 3 (more favourable case): Normal (Gaussian) distribution of the mean in the middle of the range and the standard deviation at 1/6th of the range: $\alpha = 36$.

In practice, a producer tries to centre his production of shot on a desirable content for the heats intended for constituting the blended lot, the hypothesis of a normal distribution is then logical. For shot, hypothesis 2 remains consequently an unfavourable hypothesis.

A.4.4 Estimation of the required secondary sample mass for the desired uncertainty to be achieved (fundamental error)

The number N of shot particles to be taken for achieving an uncertainty characterized by standard deviation s_s is given by [Formula \(A.4\)](#):

$$N = \frac{(1 + \rho_m^2) V_c}{s_s^2} + \rho_m^2 \tag{A.4}$$

in which parameter, ρ_m , represents the coefficient of variation of shot mass, m . This parameter, which would disappear if all shot particles had the same mass ($\rho_m = 0$), is used to account for the fact that the sampling variance depends on the product particle size heterogeneity. The presence of larger particles beside smaller particles has an unfavourable influence on the fundamental variance for a given total number N of particles in the sample.

The log-normal representation of the particle size distribution curve (i.e. of the cumulative proportion of undersize, or over size on a normal scale versus particle size on a logarithmic scale) is used to evaluate the quantity $(1 + \rho_m^2)$, as well as the quantities \tilde{m} and $\sigma_{\ln m}$ which appear in [Formula \(A.5\)](#) for mean particle mass:

$$E(m) = \tilde{m} \exp\left(-\frac{\sigma_{\ln m}^2}{2}\right) \tag{A.5}$$

The mass \tilde{m} of particle, such that particles of mass less than \tilde{m} represent as a whole 50 % of the product mass, and consequently as a correlation, that particles of mass greater than m also represent 50 % of the total mass, can be derived from the cutting size, which defines the same proportions. Similarly, $\sigma_{\ln m}$ the standard deviation of the natural logarithm of shot masses, can be derived from the slope of the particle size distribution curve.

Finally, $(1 + \rho_m^2)$ is derived from $\sigma_{\ln m}$ using [Formula \(A.6\)](#):

$$1 + \rho_{\ln m}^2 = \exp(\sigma_{\ln m}^2) \tag{A.6}$$

From [Formulae \(A.4\)](#) and [\(A.5\)](#), the mass M_e of the required shot sample for secondary sample representativity is derived.

$$M_e = N \cdot E(m) \tag{A.7}$$

$$M_e = \tilde{m} \left(\frac{(1 + \rho_m^2) V_c}{s_s^2} + \rho_m^2 \right) \exp\left(-\frac{\sigma_{\ln m}^2}{2}\right) \tag{A.8}$$

Conversely, s_s^2 can be expressed in terms of M_e from [Formula \(A.8\)](#). If s_s^2 is small in relation to V_c , which is generally the case, the second term of the second member of [Formula \(A.4\)](#) can be neglected and a relationship can be obtained which is of the form:

$$s_s^2 = \frac{\text{Constant}}{M_e} \tag{A.9}$$

Since parameters \tilde{m} , $\sigma_{\ln m}$, ρ_m and V_c are characteristic constants of the sampled product.

NOTE In this case, ρ_m^2 is negligible with respect to $\frac{(1 + \rho_m^2) V_c}{s_s^2}$.

Whatever the approximation, the number of required small ingots can be derived in any case from [Formula \(A.8\)](#) for M_e and from the mass M_1 of a small ingot obtained by melting.

$$N_s = \frac{M_e}{M_1} \tag{A.10}$$

The ratio M_e/M_1 is obviously rounded up in the upper unit.

A.5 Examples of numerical applications

[Table A.2](#) gives the values of the variations of the variance between heats V_c .

Table A.2 — Variations of the variance between heats V_c

$\varepsilon = 0,10$	Hypothesis for the distribution of heat contents in the range of the lot Nickel contents			
	Equal distribution at both limits	Uniform distribution over the whole range	Intermediate distribution	Normal (Gaussian) distribution with 6 standard deviations from $(k - \varepsilon)$ to $(k + n + \varepsilon)$
	$V_c = \frac{(n + 2\varepsilon)^2}{4}$	$V_c = \frac{(n + 2\varepsilon)^2}{12}$	$V_c = \frac{(n + 2\varepsilon)^2}{24}$	$V_c = \frac{(n + 2\varepsilon)^2}{36}$
$n = 1$	0,360	0,120	0,060	0,040
$n = 2$	1,210	0,403	0,202	0,134
$n = 3$	2,560	0,853	0,426	0,284
$n = 4$	4,410	1,470	0,735	0,490
$n = 5$	6,760	2,253	1,127	0,751

Table A.3 gives the values of N and M_e in a large range of hypotheses.

Table A.3 — Variations of values N and M_e

Magnitude of range	Particle size distribution hypothesis	Ni content distribution within the range							
		$V_c = \frac{(n + 2\varepsilon)^2}{4}$		$V_c = \frac{(n + 2\varepsilon)^2}{12}$		$V_c = \frac{(n + 2\varepsilon)^2}{24}$		$V_c = \frac{(n + 2\varepsilon)^2}{36}$	
		N	M_e (kg)	N	M_e (kg)	N	M_e (kg)	N	M_e (kg)
$n = 1$	G-1	475	0,636	160	0,214	81	0,109	55	0,073
	G-2	740	1,68	249	0,566	127	0,288	86	0,194
	G-3	614	3,34	207	1,12	105	0,571	71	0,387
$n = 2$	G-1	1 590	2,13	531	0,712	267	0,358	178	0,239
	G-2	2 477	5,62	828	1,90	417	0,947	278	0,631
	G-3	2 055	11,18	687	3,74	346	1,88	231	1,25
$n = 3$	G-1	3 361	4,50	1 119	1,50	559	0,749	375	0,502
	G-2	5 237	11,89	1 748	3,97	875	1,99	585	1,33
	G-3	4 345	23,64	1 450	7,89	726	3,95	485	2,64
$n = 4$	G-1	5 788	7,76	1 931	2,59	967	1,30	645	0,864
	G-2	9 018	20,47	3 009	6,83	1 506	3,42	1 006	2,28
	G-3	7 483	40,71	2 496	13,58	1 249	6,80	834	4,54
$n = 5$	G-1	8 871	11,89	2 958	3,96	1 481	1,98	988	1,32
	G-2	13 822	31,37	4 609	10,46	2 308	5,24	1 539	3,49
	G-3	11 468	62,39	3 824	20,80	1 915	10,42	1 277	6,95

N number of shot particles to be taken
 M_e mass of secondary sample in order to achieve $s_s = 0,05$ and $V_s = 0,0025$
 ε 0,10.
 The calculation is carried out for three hypotheses of particle size distribution:
 G-1: favourable hypothesis
 G-2: normal hypothesis
 G-3: very unfavourable hypothesis

The numbers of increments N_p and N_s to be found in Table A.1 are deduced from the following numerical values:

$$V_c = \frac{(n + 2\varepsilon)^2}{24} \tag{A.11}$$

That is:

$$\alpha = 24$$

NOTE 1 $\alpha = 12$ (see A.4.2) corresponds to an unfavourable hypothesis in the selection of these heats constituting a lot, and $\alpha = 36$ corresponds to a normal hypothesis. The value $\alpha = 24$ is an intermediate value adopted for safety reasons.

$$1 + \rho_m^2 = 4,5$$

NOTE 2 These numerical values correspond to a rather large particle size, which should not be exceeded in normal production ($d_{50} \approx 12$ mm and $d_{95} \approx 12$ mm).

$$e = 0,10$$

Mass per 1 kg small ingot (or 1 000 g for the numerical application):

$$E(m) = 2,0 \text{ g}^4$$

That is:

$$V_s = s_s^2 = 0,375 \times 10^{-3} (n + 0,2)^2$$

which gives the values indicated in Table A.4.

Table A.4 — Variation of V_s

n	V_s	s_s
1	0,000 54	0,023 2
2	0,001 82	0,042 6
3	0,003 84	0,062 0
4	0,006 62	0,081 3
5	0,010 14	0,100 7

Selection of the numbers of primary and secondary increments (N_p and N_s).

[Formula \(A.1\)](#) showed that the variance in the nickel analysis due to sampling is V_e , see [A.2](#).

If one selects an acceptable value for this sampling variance, V_e , then the known values of the primary variance, V_p , and of the secondary variance, V_s , will establish acceptable values for the number of primary increments, N_p , and the number of secondary increments, N_s .

For trade purposes one would like to set the sampling variance, V_e , as low as possible. However, there is no advantage in setting the sampling variance smaller than the variance in the analytical methods. The variances in the analytical methods (between analysts, within laboratory and between laboratories) usually range between 0,002 5 and 0,010. It is reasonable to set a target value for the sampling variance of about 0,002 5 or less.

$$V_e = \frac{V_p}{N_p} + \frac{V_s}{N_s} \leq 0,002 5 \quad (\text{A.12})$$

Values for V_p can be taken from [Table A.1](#) and values for V_s can be taken from [Table A.4](#). In both tables, the variances are shown to depend upon the range of nickel content, n . These tables can be combined (see [Table A.5](#)).

Table A.5 — Variations of V_p and V_s

n	V_p (from Table A.1)	V_s (from Table A.4)
1	0,003 6	0,000 54
2	0,004 9	0,001 82
3	0,006 4	0,003 84
4	0,008 1	0,006 62
5	0,010 0	0,010 14

Clearly, Formula (A.10) allows a wide range in choosing N_p and N_s when V_p and V_s are fixed. However, the following recommendations are made in Table A.6.

The values in Table A.6 are as shown in Table 1, taking the first line for N_p and the only line for N_s .

For N_p slightly greater values have been retained in this International Standard when the tonnage of the lot is increased, although theoretically the mass of the lot has no influence on the representativity of sampling.

It was, however, considered that such increased values of N_p , depending on the lot tonnage, could be recommended because

- when the duration of discharge increased, the duration of the sample handling made it easier, and
- this involved additional safeguards for the purchaser if the latter fears segregations due to transport (this phenomenon has never been observed in the investigations made while developing this International Standard).

Excellent representativity can thus be obtained with a small number of primary increments even with lots of a high tonnage (up to 2 500 t for example).

Table A.6 — Recommended primary and secondary increments (to achieve $V_e < 0,002 5$)

Nickel range n	Primary variance V_p	Secondary variance V_s	Recommended sampling increments		Calculated sampling variance V_e
			primary N_p	secondary N_s	
1	0,003 6	0,000 54	5	1	0,001 26
2	0,004 9	0,001 82	10	2	0,001 40
3	0,006 4	0,003 84	15	3	0,001 71
4	0,008 1	0,006 62	20	4	0,002 06
5	0,010 0	0,010 14	30	5	0,002 36

Annex B (informative)

Methods for taking a sample of size N in a supply of M items

B.1 General

It should be noted from the outset that in any method for drawing a sample from a population, two stages can be distinguished:

- a) the definition of the items to be sampled;
- b) the process of sampling itself.

It should also be recalled that in order to be representative, a sample shall be drawn in such a way that any item of the sampled population has the same probability of being drawn.

B.2 Methods for defining the items constituting the sample

Two methods can be contemplated: one is random sampling of all the items of the sample; the other is systematic periodic sampling, only the first item being designated at random.

B.2.1 Random sampling of items

In this method, all possible samples of N items (or combinations of N objects taken among M) really have an equal probability.

Let us assume that the M items of the consignment bear some kind of identification which can be translated by a special numbering from 1 to M . The problem is then reduced to drawing N distinct integers at random among the first M integers.

To this purpose N random numbers shall first be selected from the uniform distribution in the interval 0 to 1. Some tables give such numbers directly. Others (such as [Table B.1](#)) only give rows of numbers from 0 to 9, in random order, and real uniformly distributed numbers can easily be selected by taking an integer part equal to zero completed by a sequence of n decimals represented by n figures of the table.

EXAMPLE

[Table B.1](#) is an extract from a table of random numbers which allows all the concrete cases to be found in this International Standard to be dealt with.

If numbers of the uniform distribution from 0 to 1 are needed with, say, five decimal places, groups of five digits shall be taken either by column or by row or by any other systematic means. Thus, by taking the first five digits of each line for example, the following sequences of digits are obtained:

- 10275
- 28415
- 34214
- 61817, etc.

and the numbers are 0,102 75 - 0,284 15 - 0,342 14 - 0,618 17, etc.

NOTE In [Table B.1](#), the spaces between rows and columns are only for improved readability of the table, which regroups digits from 0 to 9 in a random order.

Let x_1, x_2, \dots, x_N be a series of N numbers of the uniform distribution thus obtained. All these (real) numbers are multiplied by the integer M , which gives real numbers selected at random in the interval 0 to M .

$$Mx_1, Mx_2, \dots, Mx_N$$

These real numbers are rounded up to the next highest integer:

$$E_1 = [Mx_1] + 1$$

$$E_2 = [Mx_2] + 1$$

...

$$E_N = [Mx_N] + 1$$

where $[Mx_i]$ = integer part of Mx_i .

The integers E_1, E_2, \dots, E_N then identify the items to be drawn from the population of M objects.

If this procedure results in drawing some equal numbers E_i , additional x_i numbers shall be drawn until N different values of E_i have been obtained.

B.2.2 Systematic periodic sampling of items

In this method, not all samples of N items constituted from M items of the supply have an equal probability of being obtained. Actually, this probability is zero for a very large number of them, although any specific item can have (at least approximately) the same probability of being part of the sample. This somewhat paradoxical result is explained by the no independence of individual increments.

A whole quotient of M by N , i.e. Q , is calculated and, if the division gives a remainder R (less than N), it is neglected.

An integer is then chosen at random in the sequence 1, 2, ..., $Q - 1, Q$, for example, by the method described in [B.2.1](#). Let this number be H . The items composing the sample are then defined by integers:

$$H, Q + H, 2Q + H, \dots, (N - 1)Q + H$$

It can be seen that by this method $M - NQ$ items are ignored by sampling but that only one drawing is necessary from the table of random numbers.

Because of the unequal probability of all possible samples of items being drawn, it is also necessary to specify that the theoretical formulae for calculating the sampling variance do not apply in this case, except if the lot of items has been mixed carefully, which is hardly practicable.

B.3 Drawing of N identified items

N items have been theoretically identified by integers E_1, E_2, \dots, E_N among the M items constituting the lot. The physical operation of sampling remains to be carried out without losing sight of the fact that the items generally do not bear an identification mark. As these items are trucks, wagons, containers, drums, etc., they can be numbered from 1 to M , and among them the N items designated by integers E_1, \dots, E_N shall be sampled according to the procedure described in [5.1.2](#) or [5.1.3](#), then [Clause 6](#) and the following.

NOTE The term "item" (a general concept of statistics) has the same meaning as the term "unit", which is used in the main text to designate the various form of conditioning.

Table B.1 — Table of random numbers

10 27 53 96 23	71 50 54 36 23	54 31 04 82 98	04 14 12 15 09	26 78 25 47 47
28 41 50 61 88	64 85 27 20 18	83 36 36 05 56	39 71 65 09 62	94 76 62 11 89
34 21 42 57 02	59 19 18 97 48	80 30 03 30 98	05 24 67 70 07	84 97 50 87 46
61 81 77 23 23	82 82 11 54 08	53 28 70 58 96	44 07 39 55 43	42 34 43 39 28
61 15 18 13 54	16 86 20 26 88	90 74 80 55 09	14 53 90 51 17	52 01 63 01 59
91 76 21 64 64	44 91 13 32 97	75 31 62 66 54	84 80 32 75 77	56 08 25 70 29
00 97 79 08 06	37 30 28 59 85	53 56 68 53 40	01 74 39 59 73	30 19 99 85 48
36 46 18 34 94	75 20 80 27 77	78 91 69 16 00	08 43 18 73 68	67 69 61 34 25
88 98 99 60 50	65 95 79 42 94	93 62 40 89 96	43 56 47 71 66	46 76 29 67 02
04 37 59 87 21	05 02 03 24 17	47 97 81 56 51	92 34 86 01 82	55 51 33 12 91
63 62 06 34 41	94 21 78 55 09	72 76 45 16 94	29 95 81 83 83	79 88 01 97 30
78 47 23 53 90	34 41 92 45 71	09 23 70 70 07	12 38 92 79 43	14 85 11 47 23
87 68 62 15 43	53 14 36 59 25	54 47 33 70 15	59 24 48 40 35	50 03 42 99 36
47 60 92 10 77	88 59 53 11 52	66 25 69 07 04	48 68 64 71 06	61 65 70 22 12
56 88 87 59 41	65 28 04 67 53	95 79 88 37 31	50 41 06 94 76	81 83 17 16 33
02 57 45 86 67	73 43 07 34 48	44 26 87 93 29	77 09 61 67 84	06 69 44 77 75
31 54 14 13 17	48 62 11 90 60	68 12 93 64 28	46 24 79 16 76	14 60 25 51 01
28 50 16 43 36	28 97 85 58 99	67 22 52 76 23	24 70 36 54 54	59 28 61 71 96
63 29 62 66 50	02 63 45 52 38	67 63 47 54 75	83 24 78 43 20	92 63 13 47 48
45 65 58 26 51	76 96 59 38 72	86 57 45 71 46	44 67 76 14 55	44 88 01 62 12
39 65 36 63 70	77 45 85 50 51	74 13 39 35 22	30 53 36 02 95	49 34 88 73 61
73 71 98 16 04	29 18 94 51 23	76 51 94 84 86	79 93 96 38 63	08 58 25 58 94
72 20 56 20 11	72 65 71 08 86	79 57 95 13 91	97 48 72 66 48	09 71 17 24 89
75 17 26 99 76	89 37 20 70 01	77 31 61 95 46	26 97 05 73 51	53 33 18 72 87
37 48 60 82 29	81 30 15 39 14	48 38 75 93 29	06 87 37 78 48	45 56 00 84 47
68 08 02 80 72	83 71 46 30 49	89 17 95 88 29	02 39 56 03 46	97 74 06 56 17
14 23 98 61 67	70 52 85 01 50	01 84 02 78 43	10 62 98 19 41	18 83 99 47 99
49 08 96 21 44	25 27 99 41 28	07 41 08 34 66	19 42 74 39 91	41 96 53 78 72
78 37 06 08 43	63 61 62 42 29	39 68 95 10 96	09 24 23 00 62	56 12 80 73 16
37 21 34 17 68	68 96 83 23 56	32 84 60 15 31	44 73 67 34 77	91 15 79 74 58
14 29 09 34 04	87 83 07 55 07	76 58 30 83 64	87 29 25 58 84	86 50 60 00 25
58 43 28 06 36	49 52 83 51 14	47 56 91 29 34	05 87 31 06 95	12 45 57 09 09
10 43 67 29 70	80 62 80 03 42	10 80 21 38 84	90 56 35 03 09	43 12 74 49 14
44 38 88 39 54	86 97 37 44 22	00 95 01 31 76	17 16 29 56 63	38 78 94 49 81
90 69 59 19 51	85 39 52 85 13	07 28 37 07 61	11 16 36 27 03	78 86 72 04 95

Table B.1 — *(continued)*

41 47 10 25 62	97 05 31 03 61	20 26 36 31 62	68 69 86 95 44	84 95 48 46 45
91 94 14 63 19	75 89 11 47 11	31 56 34 19 09	79 57 92 36 59	14 93 87 81 40
80 06 54 18 66	09 18 94 06 19	98 40 07 17 81	22 45 44 84 11	24 62 20 42 31
67 72 77 63 48	84 08 31 55 58	24 33 45 77 58	80 45 67 93 82	75 70 16 08 24
59 40 24 13 27	79 26 88 86 30	01 31 60 10 39	53 58 47 70 93	85 81 56 39 38
05 90 35 89 95	01 61 16 96 94	50 78 13 69 36	37 68 53 37 31	71 26 35 03 71
44 43 80 69 98	46 68 05 14 82	90 78 50 05 62	77 79 13 57 44	59 60 10 39 66
61 81 31 96 98	00 57 25 60 59	46 72 60 18 77	55 66 12 62 11	08 99 55 64 57
42 88 07 10 05	24 98 65 63 21	47 21 61 88 32	27 80 30 21 60	10 92 35 36 12
77 94 30 05 39	28 10 99 00 27	12 73 73 99 12	49 99 57 94 82	96 88 57 17 91
78 83 19 76 16	94 11 68 84 26	23 54 20 86 85	23 86 66 99 07	36 37 34 92 09
87 76 59 61 81	43 63 64 61 61	65 76 36 95 90	18 48 27 45 68	27 23 65 30 72
91 43 05 96 47	55 78 99 95 24	37 55 85 78 78	01 48 41 19 10	35 19 54 07 73
84 97 77 72 73	09 62 06 65 72	87 12 49 03 60	41 15 20 76 27	50 47 02 29 16
87 41 60 76 83	44 88 96 07 80	83 05 83 38 96	73 70 66 81 90	30 56 10 48 59

Annex C (informative)

Technical conditions for drilling and milling

C.1 General

The hardness of ferronickel small ingots may vary considerably, depending on the grades (nickel content) and especially on the quantity of impurities present (mainly C and Si).

The small ingot should be considered very hard when it falls between 180 and 600 in Vickers hardness (or equivalent hardness scales).

The cutting tools used and the conditions under which they are used should be carefully selected. Cutting is extremely difficult, because the work shall always be done dry to avoid any contamination.

NOTE Machining by drilling or milling is the most common procedure. Shaping with planning tools meeting the general requirements below is also possible. Work is then done on cut-off faces as in milling. This type of machining is, however, slower.

C.2 Case of very hard ferronickel

When machining is very difficult and involves tool wear and subsequent significant chip contamination or even impossible sampling, it is advisable to heat treat (temper) the material. The practical procedure is dependent on the metal hardness and crystalline structure. For guidance, tempering is generally useful when hardness exceeds 180 Vickers. Tempering may be carried out either on small ingots or on pieces cut off small ingots, as follows:

The small ingots or pieces are placed in a furnace at 650 °C to 800 °C for 2 h to 4 h. The furnace is then turned off and allowed to cool slowly overnight.

If a shorter period is required, the small ingots or pieces may be cooled in a few hours by immersing them in sand down to a temperature less than 200 °C.

This treatment induces oxidation of the surface when conducted in the presence of air, and decarburization to a depth of 0,5 mm to 1 mm, whatever the atmosphere in the furnace. Chips shall therefore not be taken from the surface of the metal after heat treatment. Either a 2 mm to 3 mm thickness should be cut from the surfaces and the resultant block machined, or the chips obtained from the first 2 mm to 3 mm of the sample during machining should be discarded.

C.3 Selection of cutting tools

The cutting tools used shall be made of suitable types and grades of steel, so that tools wear and resultant contamination of the chips will be reduced as much as possible.

For high-speed steel tools, [Table C.1](#) gives the specifications from ISO 4957.

The high carbon, chromium and cobalt contents ensure tool hardness; the molybdenum prevents the chips from sticking to the tool.

For hard ferronickels (for example of hardness greater than 180 Vickers), experience has shown that it is indispensable to have a steel with a cobalt content greater than or equal to 7,5 %, type S 11 appears to be the most suitable.

For less hard ferronickels, one may be satisfied with a quality containing about 5 % cobalt, for example, type S 12.

Table C.1 — Steels for high-speed tools

Grade	S 9	S 10	S 11	S 12
Designation	HS 12-1-5-5	HS 10-4-3-10	HS 2-9-1-8	HS 7-4-2-5
C %	1,45 to 1,60	1,20 to 1,35	1,05 to 1,20	1,05 to 1,20
Co %	4,70 to 5,20	9,50 to 10,5	7,50 to 8,50	4,70 to 5,20
Cr %	3,50 to 4,50	3,50 to 4,50	3,50 to 4,50	3,50 to 4,50
Mo %	0,70 to 1,00	3,20 to 3,90	9,00 to 10,0	3,50 to 4,20
V %	4,75 to 5,55	3,00 to 3,50	0,90 to 1,40	1,70 to 2,20
W %	11,5 to 13,0	9,00 to 10,0	1,30 to 1,90	6,40 to 7,40
Minimum Rockwell hardness after tempering (HRC) ^a	65	66	66	66
^a 66 HRC is equivalent to approximately 900 Vickers.				

For tungsten carbide tools: a type shall be chosen that affords a compromise between resistance to wear and toughness in order to avoid tool chafing or rupture. Selection has therefore to be made between types M 10, M 20 or M 30 of ISO 513:2012.

NOTE The data in this clause are for guidance only. They correspond to present experience of laboratories having experimented in the field.

C.4 Additional precautions

Vibration between the cutting tool and the metal being machined shall be avoided as far as possible.

When the metal is to be drilled, very short drills that are not too thin shall be used (the diameter should be no less than 12 mm and preferably between 15 mm and 20 mm). A low helix angle is also favourable, for example, a drill with a 15° helix angle could be used, as opposed to a standard drill with a helix angle of 30°.

The use of a taper-shank drill (Morse taper socket No. 2 or 3) is highly desirable.

Milling cutters shall also be short in relation to their diameter.

Finally, the machine shall be very rigid. This is readily achieved with a milling machine but more difficult to accomplish with a drilling machine, whether equipped with a milling table or not.

In either case, it shall be possible to mount the tool on the spindle using a sufficiently solid intermediate: standard ISO taper SA 40 or SA 50.

C.5 Machining parameters

The machining specifications shall be such that:

- there is very little heating of the tool, so that it does not become worn, tool wear can be detected by examining the chips produced during machining: slight yellowing is acceptable, but they should never be blue;
- the feed per tooth does not fall below a minimum value during either drilling or milling, so that the material does not undergo work hardening; this is necessary for normal operation of the tool, free from vibration, wear and abnormal heating.

The parameters given in [Table C.2](#) should be considered to achieve a good compromise.

The relationships of these parameters are expressed in the following formulae:

$$V_1 = \frac{\pi \times DN}{1\,000} \quad (\text{C.1})$$

$$a = \frac{V_2}{N \times d} \quad (\text{C.2})$$

(valid with the above-mentioned units)

Good machining conditions are obtained by selecting appropriate values for V_1 and a and then adjusting N and V_2 accordingly on each machine.

NOTE In the case of milling, the linear cutting speed is applied in a rigorous manner, the above-mentioned diameter D is always the diameter corresponding to the cutting point of the rotating tool. In the case of a drill, the formula V_1 normally applies to the cutting portion of the drill which is located on the outer diameter, but V_1 has had significance for the working zones of the drill on a smaller diameter and above all for the point, which penetrates by pressure rather than by cutting. This is why the set of cutting parameters can be controlled better in milling than in drilling.

Examples of recommended specifications are given in [Table C.3](#).

Understandably, for low-hardness metal machining, the maximum values given in [Table C.3](#) can be increased.

To achieve these specifications in practice, machining shall be done within the following limits:

$N = 30 \text{ min}^{-1}$ to 100 min^{-1} when drilling

40 min^{-1} to 100 min^{-1} when milling

$V_2 = 3 \text{ mm/min}$ to 10 mm/min when drilling

5 mm/min to 20 mm/min when milling

Table C.2 — Parameters to be considered

Symbol	Parameter	Unit of measurement
N	Speed of rotation of the tool	revolution per minute
D	Diameter of drill or milling cutter	millimetre
d	Number of teeth ^a	—
V_1	Linear cutting speed	meter per minute
V_2	Rate of longitudinal feed or cross-feed (milling) or of vertical feed (drilling)	millimetre per minute
a	Feed per tooth	millimetre per tooth

^a In mechanical terms, each tooth corresponds, in the case of a drill (examples in [C.6.1](#), [C.6.2](#) and [C.6.3](#)) or in the case of end mill cutters (examples in [C.6.4](#), [C.6.5](#) and [C.6.6](#)), to one flute.

Table C.3 — Examples of recommended specifications

Tool	V_L	V_L	a	a	a
	maximum m/min	desirable m/min	maximum mm/tooth	desirable mm/tooth	minimum mm/tooth
High-speed steel drill	4	2 to 3	0,05	0,04	0,03
Tungsten carbide drill	10 to 12	4 to 7	0,03	0,02	0,015
High-speed steel chip-breaking milling cutter	6	2 to 3	0,03	0,015 to 0,02	0,01
High-speed steel end milling cutter	6	2 to 4	0,05	0,03 to 0,04	0,02

C.6 Examples of suitable tools

The descriptions below are given for guidance only. They should facilitate research for the reader and also testing for selecting the most appropriate cutting tools from the various producers in each country.

Only a life duration test with macro graphical cutting lip examination can be used for drawing reliable conclusions. A high-performing tool type or sharpening obtained at one supplier may perform less well at another. The following are examples only.

C.6.1 High-speed steel drill

Diameter: 15 mm to 20 mm

Morse taper: No. 2 or 3

Useful length: 60 mm to 70 mm

Helix angle: 15° (or, failing this, 30°)

Point angle: 140° (or, failing this, 130°, but no less)

Clearance angle: 5° to 7°

Back-clearance angle: About 15°

Rake angle: Positive (i.e. in the same direction as the helix), but may be 3° to 6°

Drill sharpening: 3 rake angles: clearance, back-clearance and web clearance

Web thinning permits having a cross-edge of 1 mm to 2 mm.

C.6.2 Carbide drill

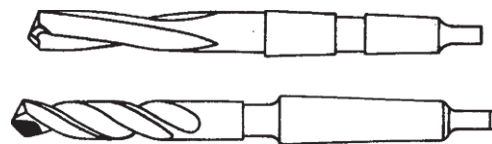

Figure C.1 — Carbide drill

Diameter: Approximately 15 mm

Useful length: Approximately 35 mm

Morse taper: No. 2

Helix angle: 10° to 15° (or, failing these, 30°)

Point angle: 130°

Clearance angle: 2° to 4°

Back-clearance angle: About 15°

Rake angle: Positive (i.e. in the same direction as the helix) but may be 2° to 5°

Sharpening: 3 rake angles: clearance, back-clearance and web clearance.

The remark for web thinning as in [C.6.1](#) applies here. Here it is very important not to reduce the cross-edge to less than 1 mm. Otherwise, the risk of rupture of the point is very high.

This type of drill is not to be used with the hardest ferronickels. The risk of carbide flaking or of point rupture increases when hardness increases and the steel land wear beyond the carbide tip becomes very important due to blocked chips inside the hole inducing friction. (The latter disadvantage is suppressed when using solid carbide tools.)

C.6.3 Oil-hole drill

These drills are used with compressed air instead of oil feeding. A special coupling ring is used for this purpose (see [Table C.4](#) and [Figure C.2](#)).

Such drills are not made of steels with high cobalt and molybdenum contents. Hence, they cannot be used for very hard ferronickels.

Chip recovery as depicted in [Figure C.6](#) shall be used with chips drilling technique.

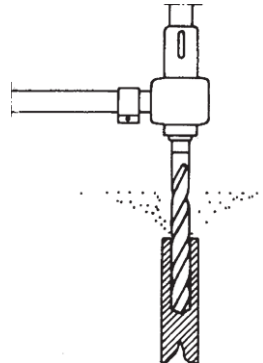

Figure C.2 — Oil-hole drill

Table C.4 — Characteristics of oil-hole drills

Characteristic	Drill diameter	
	15,875 mm	19,050 mm
Total length	241,3 mm	266,7 mm
Groove length	123,825 mm	149,225 mm
Helix angle	34°	34°
Point angle	118°	118°
Clearance angle ^a	10°	10°
Black-clearance angle ^b (approximately)	10°	10°
^a As measured at the intersection of the side flank with the land (margin). ^b This angle shall be altered to improve performance. Such sharpening or so-called “flattened-lip” reduces the effective inclination of the axis with respect to the side flank and has proved advantageous for many applications.		

C.6.4 Chip-breaking mill cutter

NOTE For the terminology of milling cutters see ISO 3855.



Figure C.3 — Chip-breaking mill cutter

Diameter: 20 mm to 30 mm

Number of teeth (or flutes): 4, 5, or 6

Profile of the longitudinal edge of the length of each flute: Rough-formed cutting edge, round profile

Useful length: 30 mm to 45 mm

Clearance angle: 3° to 4°

Rake angle: 2° to 5°

Mounting: By an intermediate socket with SA 40 or SA 50 taper

This type of milling cutter is suitable for working with the cylindrical part.

Cut depth: 0,5 mm to 2 mm, depending on the hardness of the material

C.6.5 End-mill cutter

NOTE For the terminology of milling cutters see ISO 3855.



Figure C.4 — End-mill cutter

Diameter: 20 mm to 50 mm

Morse taper: No. 3 or 4

Number of teeth (or flutes): 4, 5 or 6

Useful length: 35 mm to 75 mm

Clearance angle: 4° to 6°

Rake angle: 2° to 5°

This type of milling cutter is more suitable for working with the end than with the cylindrical part.

Cut depth: 0,5 mm to 2 mm, depending on the hardness of the material

C.6.6 Diesinking cutter head



Figure C.5 — Diesinking cutter head

Diameter: 50 mm or 80 mm

Number of teeth (or flutes): 6 or 10

Useful length: 10 mm to 15 mm

Clearance angle: 4° to 6°

Rake angle: 2° to 5°

Mounting: by an intermediate socket with socket with SA 40 or SA 50 taper

This type of milling cutter is used only on end but under the same conditions as an end mill cutter.

Cut depth: 0,5 mm to 2 mm, depending on the hardness of the material

From life duration tests made by some producers, it appears that the lowest wear (or greatest permissible number of cuts before wearing out and sharpening of the milling cutter) is obtained with this type of cutter.

NOTE Tungsten carbide milling cutters have a shorter life than steel milling cutters for ferronickel machining.

C.7 Drilling chip collection box

An assembly similar to that of [Figure C.6](#) may be used for this purpose; it is particularly suited when using an oil-hole drill with compressed air supply (see [C.6.3](#)). This assembly shall be made of materials which will not contaminate the chips.

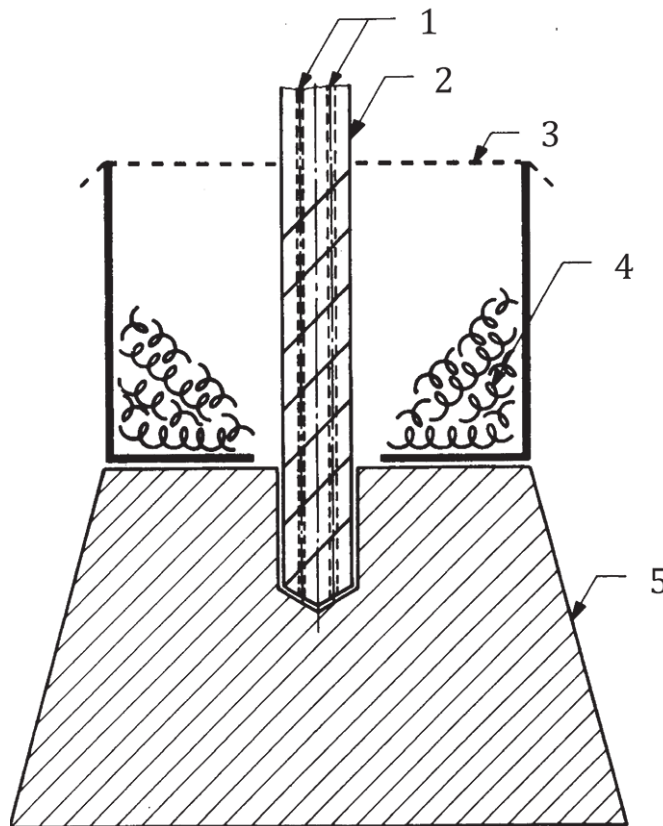

Key

- 1 compressed air
- 2 drill
- 3 wire mesh cover
- 4 chips
- 5 ferronickel ingot or piece

NOTE For use especially when using oil-hole drills fed with compressed air.

Figure C.6 — Drilling chip collection box

Bibliography

- [1] ISO 3855, *Milling cutters — Nomenclature*
- [2] ISO 4957, *Tool steels*
- [3] ISO 6352:1985, *Ferronickel — Determination of nickel content — Dimethylglyoxime gravimetric method*
- [4] ISO 6501, *Ferronickel — Specification and delivery requirements*

