**Aerospace — Nuts, hexagonal, self-locking,
with MJ threads, classifications: 1 100 MPa
(at ambient temperature)/235 °C, 1 100 MPa
(at ambient temperature)/315 °C and
1 100 MPa (at ambient temperature)/
425 °C — Dimensions**

*Aéronautique et espace — Écrous hexagonaux à freinage interne, à
filetage MJ, classifications: 1 100 MPa (à température ambiante)/235 °C,
1 100 MPa (à température ambiante)/315 °C et 1 100 MPa (à température
ambiante)/425 °C — Dimensions*



Reference number
ISO 7995:2002(E)

© ISO 2002

PDF disclaimer

This PDF file may contain embedded typefaces. In accordance with Adobe's licensing policy, this file may be printed or viewed but shall not be edited unless the typefaces which are embedded are licensed to and installed on the computer performing the editing. In downloading this file, parties accept therein the responsibility of not infringing Adobe's licensing policy. The ISO Central Secretariat accepts no liability in this area.

Adobe is a trademark of Adobe Systems Incorporated.

Details of the software products used to create this PDF file can be found in the General Info relative to the file; the PDF-creation parameters were optimized for printing. Every care has been taken to ensure that the file is suitable for use by ISO member bodies. In the unlikely event that a problem relating to it is found, please inform the Central Secretariat at the address given below.

© ISO 2002

All rights reserved. Unless otherwise specified, no part of this publication may be reproduced or utilized in any form or by any means, electronic or mechanical, including photocopying and microfilm, without permission in writing from either ISO at the address below or ISO's member body in the country of the requester.

ISO copyright office
Case postale 56 • CH-1211 Geneva 20
Tel. + 41 22 749 01 11
Fax + 41 22 749 09 47
E-mail copyright@iso.ch
Web www.iso.ch

Printed in Switzerland

Foreword

ISO (the International Organization for Standardization) is a worldwide federation of national standards bodies (ISO member bodies). The work of preparing International Standards is normally carried out through ISO technical committees. Each member body interested in a subject for which a technical committee has been established has the right to be represented on that committee. International organizations, governmental and non-governmental, in liaison with ISO, also take part in the work. ISO collaborates closely with the International Electrotechnical Commission (IEC) on all matters of electrotechnical standardization.

International Standards are drafted in accordance with the rules given in the ISO/IEC Directives, Part 3.

The main task of technical committees is to prepare International Standards. Draft International Standards adopted by the technical committees are circulated to the member bodies for voting. Publication as an International Standard requires approval by at least 75 % of the member bodies casting a vote.

Attention is drawn to the possibility that some of the elements of this International Standard may be the subject of patent rights. ISO shall not be held responsible for identifying any or all such patent rights.

ISO 7995 was prepared by Technical Committee ISO/TC 20, *Aircraft and space vehicles*, Subcommittee SC 4, *Aerospace fastener systems*.

This third edition cancels and replaces the second edition (ISO 7995:1988), which has been technically revised.

.....

Introduction

The dimensions specified in this International Standard have been determined to allow production of a part which will satisfy the requirements of the procurement specification ISO 5858.

Aerospace — Nuts, hexagonal, self-locking, with MJ threads, classifications: 1 100 MPa (at ambient temperature)/235 °C, 1 100 MPa (at ambient temperature)/315 °C and 1 100 MPa (at ambient temperature)/425 °C — Dimensions

1 Scope

This International Standard specifies the dimensions of hexagonal nuts, with MJ threads and a self-locking feature achieved by forming the upper portion out-of-round, for classifications: 1 100 MPa¹/235 °C², 1 100 MPa¹/315 °C², 1 100 MPa¹/425 °C².

This International Standard is only applicable for the compilation of aerospace product standards.

2 Normative references

The following normative documents contain provisions which, through reference in this text, constitute provisions of this International Standard. For dated references, subsequent amendments to, or revisions of, any of these publications do not apply. However, parties to agreements based on this International Standard are encouraged to investigate the possibility of applying the most recent editions of the normative documents indicated below. For undated references, the latest edition of the normative document referred to applies. Members of ISO and IEC maintain registers of currently valid International Standards.

ISO 5855-2:1999, *Aerospace — MJ threads — Part 2: Limit dimensions for bolts and nuts*

ISO 8788:2000, *Aerospace — Nuts, metric — Tolerances of form and position*

3 Configuration and dimensions

See Figure 1 and Table 1. Dimensions and tolerances are expressed in millimetres. They apply after any surface coating(s) but before the application of any lubricant.

1) Corresponds to the minimum tensile stress which the nut is able to withstand at ambient temperature without breaking or cracking when tested with a bolt of a higher strength class.

2) Maximum temperature that the nut is able to withstand, without permanent alteration to its original characteristics, after ambient temperature has been restored. The maximum temperature is conditioned by the sealing ring material or by the surface treatment.

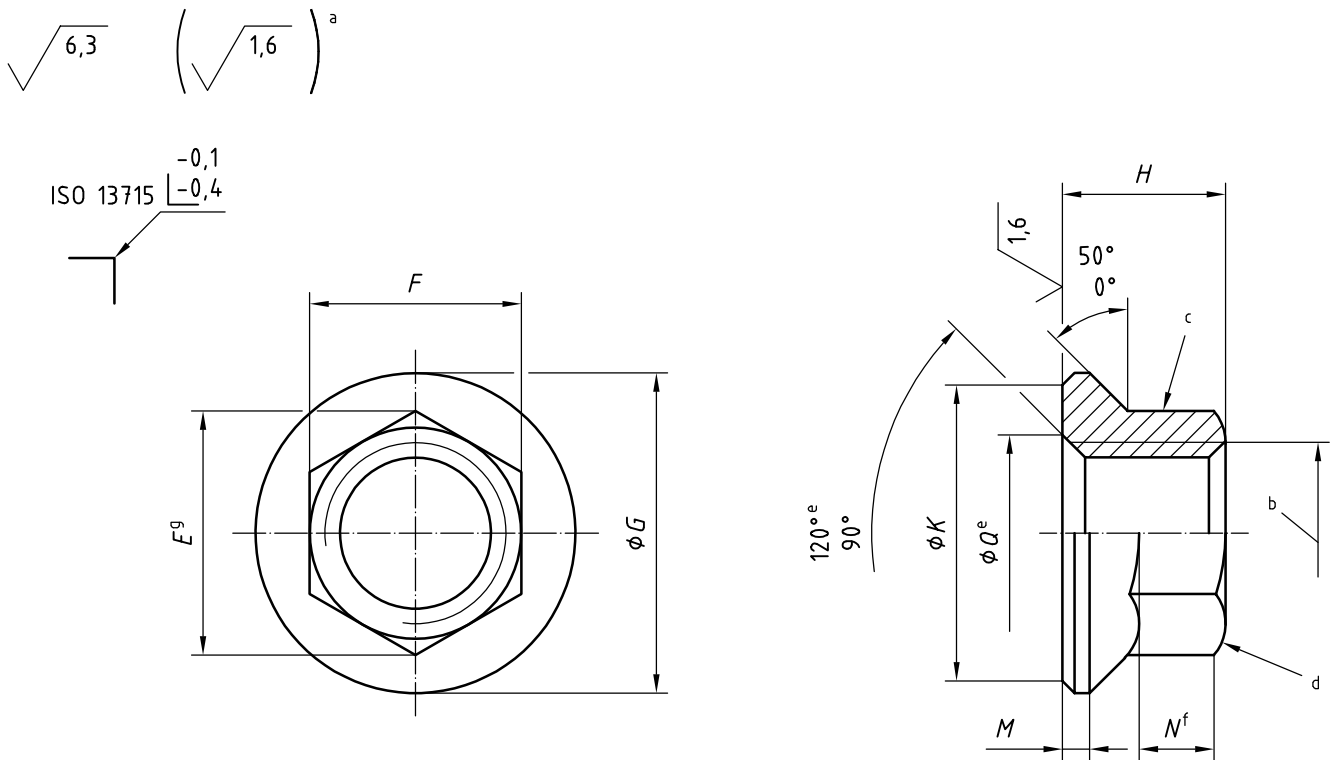

Tolerances of form and position shall conform to those specified in ISO 8788. Details of form not stated are at the manufacturer's discretion.

- a These values, in micrometres, apply before any surface coating(s) is(are) applied. The values do not apply to threads the surface texture of which will be as achieved by the usual manufacturing methods.
- b Thread.
- c Form out-of-round in this area to achieve the self-locking requirement. Tooling marks permissible in this area.
- d Chamfer, radius or broken edge.
- e All forms of entry (radius or chamfer) permissible within the limiting dimensions.
- f Wrench pad engagement.
- g Applies before forming out-of-round, but finished nuts shall fit a standard socket wrench.

Figure 1

Table 1

Diameter code	Thread ^a	<i>E</i>	<i>F</i>		<i>G</i>	<i>H</i>	<i>K</i>	<i>M</i>	<i>N</i>	<i>Q</i>	
		min.	nom.	tol.	max.	max.	min.	min.	min.	max.	min.
030	MJ3 × 0,5-4H6H	4,2	4	h12	6	3	5,3	0,4	1,2	3,8	3,2
040	MJ4 × 0,7-4H6H	5,3	5		7,4	4	6,7	0,5	1,5	4,8	4,2
050	MJ5 × 0,8-4H6H	6,5	6		9,1	5	8,3	0,6	2	5,8	5,2
060	MJ6 × 1-4H5H	7,6	7		10,6	5,4	9,8	0,7	2,3	7,1	6,3
070	MJ7 × 1-4H5H	8,7	8		12,1	6,3	11,3	0,8	2,7	8,1	7,3
080	MJ8 × 1-4H5H	10,9	10	h13	13,6	7,2	12,8	0,9	3,2	9,1	8,3
100	MJ10 × 1,25-4H5H	13,2	12		16,8	9	15,8	1,1	3,8	11,1	10,3
120	MJ12 × 1,25-4H5H	15,5	14		19,9	10,8	18,8	1,4	4,5	13,1	12,3

^a In accordance with ISO 5855-2. In the self-locking zone, the tolerances apply before forming out-of-round.

Bibliography

- [1] ISO 5858:1999, *Aerospace — Nuts, self-locking, with maximum operating temperature less than or equal to 425 °C — Procurement specification*
- [2] ISO 13715:2000, *Technical drawings — Edges of undefined shape — Vocabulary and indications*

ICS 49.030.30

Price based on 4 pages

© ISO 2002 – All rights reserved