**Iron ores for blast furnace feedstocks —
Determination of reduction under load**

*Minerais de fer pour charges de hauts fourneaux — Détermination de la
réduction sous charge*



Reference number
ISO 7992:2007(E)

© ISO 2007

PDF disclaimer

This PDF file may contain embedded typefaces. In accordance with Adobe's licensing policy, this file may be printed or viewed but shall not be edited unless the typefaces which are embedded are licensed to and installed on the computer performing the editing. In downloading this file, parties accept therein the responsibility of not infringing Adobe's licensing policy. The ISO Central Secretariat accepts no liability in this area.

Adobe is a trademark of Adobe Systems Incorporated.

Details of the software products used to create this PDF file can be found in the General Info relative to the file; the PDF-creation parameters were optimized for printing. Every care has been taken to ensure that the file is suitable for use by ISO member bodies. In the unlikely event that a problem relating to it is found, please inform the Central Secretariat at the address given below.



COPYRIGHT PROTECTED DOCUMENT

© ISO 2007

All rights reserved. Unless otherwise specified, no part of this publication may be reproduced or utilized in any form or by any means, electronic or mechanical, including photocopying and microfilm, without permission in writing from either ISO at the address below or ISO's member body in the country of the requester.

ISO copyright office
Case postale 56 • CH-1211 Geneva 20
Tel. + 41 22 749 01 11
Fax + 41 22 749 09 47
E-mail copyright@iso.org
Web www.iso.org

Published in Switzerland

Contents

Page

| | |
|------------------------------------------------------------------------------------------------|-----------|
| Foreword | iv |
| Introduction | v |
| 1 Scope | 1 |
| 2 Normative references | 1 |
| 3 Terms and definitions | 1 |
| 4 Principle | 1 |
| 5 Sampling, sample preparation and preparation of test portions | 2 |
| 6 Apparatus | 2 |
| 7 Test conditions | 3 |
| 8 Procedure | 4 |
| 9 Expression of results | 5 |
| 10 Test report | 6 |
| 11 Verification | 7 |
| Annex A (normative) Flowsheet of the procedure for the acceptance of test results | 11 |
| Annex B (informative) Derivation of equation for reducibility | 12 |

Foreword

ISO (the International Organization for Standardization) is a worldwide federation of national standards bodies (ISO member bodies). The work of preparing International Standards is normally carried out through ISO technical committees. Each member body interested in a subject for which a technical committee has been established has the right to be represented on that committee. International organizations, governmental and non-governmental, in liaison with ISO, also take part in the work. ISO collaborates closely with the International Electrotechnical Commission (IEC) on all matters of electrotechnical standardization.

International Standards are drafted in accordance with the rules given in the ISO/IEC Directives, Part 2.

The main task of technical committees is to prepare International Standards. Draft International Standards adopted by the technical committees are circulated to the member bodies for voting. Publication as an International Standard requires approval by at least 75 % of the member bodies casting a vote.

Attention is drawn to the possibility that some of the elements of this document may be the subject of patent rights. ISO shall not be held responsible for identifying any or all such patent rights.

ISO 7992 was prepared by Technical Committee ISO/TC 102, *Iron ore and direct reduced iron*, Subcommittee SC 3, *Physical testing*.

This second edition cancels and replaces the first edition (ISO 7992:1992), which has been revised to homogenise with other physical test standards.

Introduction

This International Standard concerns one of a number of physical test methods that have been developed to measure various physical parameters and to evaluate the behaviour of iron ores, including reducibility, disintegration, crushing strength, apparent density, etc. This method was developed to provide a uniform procedure, validated by collaborative testing, to facilitate comparisons of tests made in different laboratories.

The results of this test should be considered in conjunction with other tests used to evaluate the quality of iron ores as feedstocks for blast furnace processes.

This International Standard may be used to provide test results as part of a production quality control system, as a basis of a contract, or as part of a research project.

.....

Iron ores for blast furnace feedstocks — Determination of reduction under load

CAUTION This International Standard may involve hazardous materials, operations and equipment. This standard does not purport to address all of the safety issues associated with its use. It is the responsibility of the user of this International Standard to establish appropriate safety and health practices and determine the applicability of regulatory limitations prior to its use.

1 Scope

This International Standard specifies a method to provide a relative measure for evaluating the structural stability of iron ores, when reduced under conditions resembling those prevailing in the reduction zone of a blast furnace.

This International Standard is applicable to lump ores and hot-bonded pellets.

2 Normative references

The following referenced documents are indispensable for the application of this document. For dated references, only the edition cited applies. For undated references, the latest edition of the referenced document (including any amendments) applies.

ISO 2597-1:2006, *Iron ores — Determination of total iron content — Part 1: Titrimetric method after tin (II) chloride reduction.*

ISO 3082:2000 ¹⁾, *Iron ores — Sampling and sample preparation procedures*

ISO 9035:1989, *Iron ores — Determination of acid-soluble iron(II) content — Titrimetric method*

ISO 9507:1990, *Iron ores — Determination of total iron content — Titanium (III) chloride reduction methods*

ISO 11323:2002, *Iron ore and direct reduced iron — Vocabulary*

3 Terms and definitions

For the purposes of this document, the terms and definitions given in ISO 11323 apply.

4 Principle

The test portion is isothermally reduced in a fixed bed, at 1 050 °C, under static load, using a reducing gas consisting of CO, H₂ and N₂, until a degree of reduction of 80 % is obtained. The differential gas pressure across the bed and the change in the test bed height are measured at 80 % reduction.

1) Under revision to incorporate ISO 10836 – *Iron ores – Method of sampling and sample preparation for physical testing.*

5 Sampling, sample preparation and preparation of test portions

5.1 Sampling and sample preparation

Sampling of a lot and preparation of a test sample shall be in accordance with ISO 3082.

The size range for pellets and lump ores shall be – 12,5 mm + 10,0 mm.

A test sample of at least 6,0 kg, on a dry basis, of the sized material shall be obtained.

Oven-dry the test sample to constant mass at $105\text{ °C} \pm 5\text{ °C}$ and cool it to room temperature before preparation of the test portions.

NOTE Constant mass is achieved when the difference in mass between two subsequent measurements becomes less than 0,05 % of the initial mass of the test sample.

5.2 Preparation of test portions

Collect each test portion by taking ore particles at random.

NOTE Manual methods of division recommended in ISO 3082, such as riffing, can be applied to obtain the test portions.

At least 5 test portions, each of approximately 1 200 g (\pm the mass of 1 particle) shall be prepared from the test sample: 4 test portions for testing, 1 for chemical analysis.

Weigh the test portions to the nearest 1 g and register the mass of each test portion on its recipient label.

6 Apparatus

6.1 General

The test apparatus shall comprise:

- a) ordinary laboratory equipment, such as an oven, hand tools, a time-control device and safety equipment;
- b) a reduction-tube assembly, including a loading device, manometer and height-measuring device;
- c) a furnace, equipped with a balance for permitting the mass loss of the test portion to be read at any time during the test;
- d) a system to supply the gases and regulate the flow rates;
- e) a weighing device.

Figure 1 shows an example of the test apparatus.

6.2 Reduction tube, with a double wall made of non-scaling, heat-resistant metal to withstand temperatures higher than $1\ 050\text{ °C}$ and resistant to deformation. The internal diameter of the inner reduction tube shall be $125\text{ mm} \pm 1\text{ mm}$. A removable perforated plate, made of non-scaling, heat-resistant metal to withstand temperatures higher than $1\ 050\text{ °C}$, shall be mounted in the reduction tube to support the test portion and to ensure uniform gas flow through it. The perforated plate shall be 10 mm thick, with a diameter 1 mm less than the tube internal diameter. The holes in the plate shall be 3 mm to 4 mm in diameter, at a pitch center distance of 5 mm to 6 mm. The internal diameter of the outer reduction tube shall be enough to allow gas flow preheating before entering the inner reduction tube.

Figure 2 shows an example of a reduction tube. Figure 3 shows the principle for oxygen flushing of thermocouples to avoid mismeasurement due to carbon deposition.

6.3 Loading device, capable of supplying a total static load of $50 \text{ kPa} \pm 2 \text{ kPa}$ evenly to the test portion. The load shall be transferred by means of a ram with a rigid perforated footplate, so as to distribute it evenly to the surface of the porcelain balls placed on top of the test portion. The foot-plate shall be 10 mm thick, with a diameter 1 mm less than the tube internal diameter. The holes in the plate shall be 3 mm to 4 mm in diameter, at a pitch center distance of 5 mm to 6 mm.

6.4 Device for measuring differential gas pressure, having a resolution of 0,01 kPa.

6.5 Height-measuring device, having a resolution of 0,1 mm.

6.6 Porcelain balls, having a size range between 10,0 mm and 12,5 mm.

6.7 Furnace, having a heating capacity and temperature control able to maintain the entire test portion, as well as the gas entering the bed at $1\ 050 \text{ }^\circ\text{C} \pm 10 \text{ }^\circ\text{C}$.

6.8 Balance, capable of weighing the reduction-tube assembly, including the test portion, to an accuracy of 1 g. The balance shall have an appropriate device to suspend the reduction-tube assembly.

6.9 Gas-supply system, capable of supplying the gases and regulating gas flow rates. A frictionless connection between the gas-supply system and the reduction tube shall be ensured to not affect the weight loss determination during reduction.

6.10 Weighing device, capable of weighing the test sample and test portions to an accuracy of 1 g.

7 Test conditions

7.1 General

Volumes and flow rates of gases used are as measured at a reference temperature of $0 \text{ }^\circ\text{C}$ and at a reference atmospheric pressure of 101,325 kPa (1,013 25 bar).

7.2 Reducing gas

7.2.1 Composition

The reducing gas shall consist of:

| | |
|----------------|----------------------------------------------------------|
| CO | $40,0 \text{ } \% \pm 0,5 \text{ } \%$ (volume fraction) |
| H ₂ | $2,0 \text{ } \% \pm 0,5 \text{ } \%$ (volume fraction) |
| N ₂ | $58,0 \text{ } \% \pm 0,5 \text{ } \%$ (volume fraction) |

7.2.2 Purity

Impurities in the reducing gas shall not exceed:

| | |
|------------------|-------------------------|
| CO ₂ | 0,2 % (volume fraction) |
| O ₂ | 0,1 % (volume fraction) |
| H ₂ O | 0,2 % (volume fraction) |

7.2.3 Flow rate

The flow rate of the reducing gas, during the entire reducing period, shall be maintained at 83 L/min \pm 1 L/min.

7.3 Heating and cooling gas

Nitrogen (N₂) shall be used as the heating and cooling gas. Impurities shall not exceed 0,1 % (volume fraction).

The flow rate of N₂ shall be maintained at 50 L/min until the test portion reaches 1 050 °C and at 83 L/min during the temperature-equilibration period. If desired, the test portion may be cooled under nitrogen to below 100 °C. During cooling, the flow of N₂ shall be maintained at 5 L/min.

7.4 Temperature of the test portion

The temperature of the entire test portion shall be maintained at 1 050 °C \pm 10 °C during the entire reducing period and, as such, the reducing gas shall be preheated before entering the test portion.

7.5 Loading of the test portion

During the entire heating and reducing periods, the test portion shall be subjected to a constant load of 50 kPa \pm 2 kPa applied over the surface of the bed.

8 Procedure

8.1 Number of determinations for the test

Carry out the test as many times as required by the procedure in Annex A.

8.2 Chemical analysis

Take, at random, one of the test portions prepared in 5.2 and use it for the determination of the iron(II) oxide content (w_1) in accordance with ISO 9035 and the total iron content (w_2) in accordance with ISO 2597-1 or ISO 9507.

8.3 Reduction

In order to achieve a more uniform gas flow, place a double-layer bed of porcelain balls (6.6) in the reduction tube (6.2) on the perforated plate, and level its surface. Measure the height of the top surface of the porcelain layer.

Take, at random, another test portion prepared in 5.2 and record its mass (m_0). Place it on the bed of porcelain balls and level its surface.

Place a further double layer of the porcelain balls upon the test portion, and level its surface. Measure the height of the top surface of this porcelain layer.

Close the top of the reduction tube by connecting the heating assembly containing the loading device (6.3) to the reduction tube. Insert the reduction-tube assembly into the furnace (6.7) and suspend it centrally from the balance (6.8), ensuring that there is no contact with the furnace wall or heating elements.

NOTE Since the heating rate under inert gas flow has no influence on the test results, the reduction tube containing the test portion may be inserted into the heated furnace.

Connect the thermocouple, ensuring that its tip is at the central position, as shown in Figure 2. Connect the measurement devices for the differential pressure (6.4) and for the change in the height of the test bed (6.5).

Connect the gas-supply system (6.9), the discharge line and the compressed air to the loading device. Apply a load of $50 \text{ kPa} \pm 2 \text{ kPa}$.

Pass a flow of N_2 through the test portion at a rate of 50 L/min and commence heating. When the temperature of the test portion approaches $1\,050 \text{ }^\circ\text{C}$, increase the flow rate to 83 L/min . Continue heating while maintaining the flow of N_2 , until the mass of the test portion is constant and the temperature is constant at $1\,050 \text{ }^\circ\text{C} \pm 10 \text{ }^\circ\text{C}$ for 10 min .

DANGER — Carbon monoxide and the reducing gas, which contains carbon monoxide, are toxic and therefore hazardous. Testing shall be carried out in a well ventilated area or under a hood. Precautions should be taken for the safety of the operator, in accordance with the safety codes of each country.

Record the mass of the test portion (m_1) and the time. Immediately introduce the reducing gas at a flow rate of 83 L/min to replace the N_2 . Record the differential pressure across the test bed, the height of the test bed and the mass of the test portion (m_t) continuously, or at least every 5 min for the first 30 min , and thereafter at 10 min intervals.

Calculate the degree of reduction, R_t , relative to the iron(III) state, after $t \text{ min}$, as follows ²⁾:

$$R_t = \left(\frac{0,111 w_1}{0,430 w_2} + \frac{m_1 - m_t}{m_0 \times 0,430 w_2} \times 100 \right) \times 100 \quad (1)$$

where

m_0 is the mass, in grams, of the test portion;

m_1 is the mass, in grams, of the test portion immediately before starting the reduction;

m_t is the mass, in grams, of the test portion, after reduction time t ;

w_1 is the iron(II) oxide content, as a percentage by mass, of the test sample prior to the test, determined in accordance with ISO 9035, calculated from the iron(II) content by multiplying it by the oxide conversion factor $\text{FeO/Fe(II)} = 1,286$.

w_2 is the total iron content, as a percentage by mass, of the test portion prior to the test, determined in accordance with ISO 2597-1 or ISO 9507.

When the degree of reduction reaches 80% , turn off the power, stop the flow of the reducing gas and record the time.

NOTE If, after 4 h , 80% of reduction has not been achieved, the reduction may be stopped.

If any further evaluations are to be performed on the reduced test portion, the flow of N_2 after reduction should be continued until the test portion reaches room temperature.

9 Expression of results

9.1 Preparation of the reduction curve

Prepare the reduction curve by plotting the degree of reduction R_t against time t .

2) The derivation of the equation is given in Annex B.

9.2 Calculation of the differential pressure at 80 % reduction (Δp_{80})

The differential pressure at 80 % reduction, expressed in kPa, is calculated as follows.

Plot the differential gas pressure against the degree of reduction and read off, from the curve, the differential pressure (Δp_{80}) corresponding to 80 % reduction.

Record the result to 2 decimal places.

9.3 Calculation of the change in the height of the test bed at 80 % reduction (Δh_{80})

The change in the height of the test bed at 80 % reduction, Δh_{80} , expressed as a percentage, is calculated as follows.

Plot the percentage change in the height of the test bed against the degree of reduction and read off, from the curve, the percentage change in the height of the test bed (Δh_{80}) corresponding to 80 % reduction.

Record the result to one decimal place.

9.4 Repeatability and acceptance of test results

Follow the procedure in Annex A for Δp_{80} index by using the repeatability $r = 0,30 \overline{\Delta p_{80}}$ (kPa). The results shall be reported to 2 decimal places.

10 Test report

The test report shall include the following information:

- a) a reference to this International Standard, i.e. ISO 7992:2007;
- b) all details necessary for the identification of the sample;
- c) the name and address of the test laboratory;
- d) the date of the test;
- e) the date of the test report;
- f) the signature of the person responsible for the test;
- g) details of any operation and any test conditions not specified in this International Standard or regarded as optional, as well as any incident which may have had an influence on the results;
- h) the differential gas pressure at 80 % reduction, Δp_{80} ;
- i) the change in the height of the test bed at 80 % reduction, Δh_{80} ;
- j) the total iron and iron(II) contents of the test portion before reduction;
- k) the time taken to reach 80 % reduction;
- l) the reducibility dR/dt (O/Fe = 0,9), expressed in percentage per minute.

11 Verification

Regular checking of the apparatus is essential to assure test result reliability. The frequency of checking is a matter for each laboratory to determine.

The conditions of the following items shall be checked:

- weighing device;
- reduction tube;
- temperature control and measurement devices;
- loading device;
- gas flow meters;
- purity of gases;
- device for measuring the differential gas pressure;
- height-measuring device;
- cleanliness of porcelain balls;
- balance;
- time-control device.

It is recommended that internal reference material be prepared and used periodically to check test repeatability.

Appropriate records of verification activities shall be maintained.

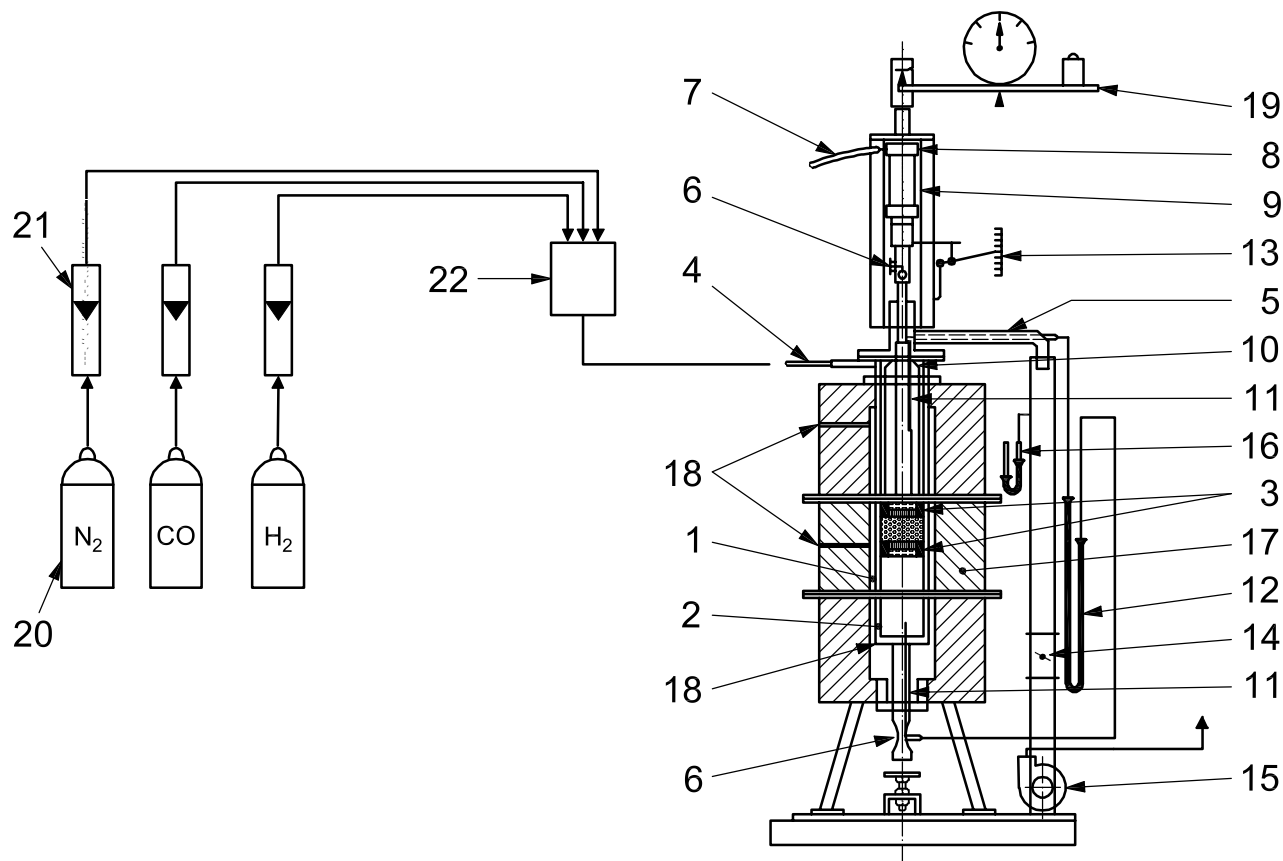

Key

Reduction tube

- 1 outer reduction tube
- 2 inner reduction tube
- 3 upper and lower perforated plates comprising test portion
- 4 gas inlet
- 5 gas outlet
- 6 thermocouple for measuring the reduction temperature

Loading device

- 7 compressed air inlet
- 8 pressure cylinder
- 9 frame for pressure cylinder
- 10 loading ram

Device for measuring differential gas pressure

- 11 differential-gas-pressure upper and lower probes
- 12 differential-gas-pressure manometer

Height-measuring device

- 13 linear scale

Waste gas

- 14 throttle valve
- 15 waste-gas fan
- 16 suction gauge

Furnace

- 17 electrically heated furnace
- 18 furnace-wall thermocouples
- 19 balance

Gas-supply system

- 20 gas cylinders
- 21 gas flowmeters
- 22 mixing vessel

Figure 1 — Example of the test apparatus (schematic diagram)

Dimensions in millimetres

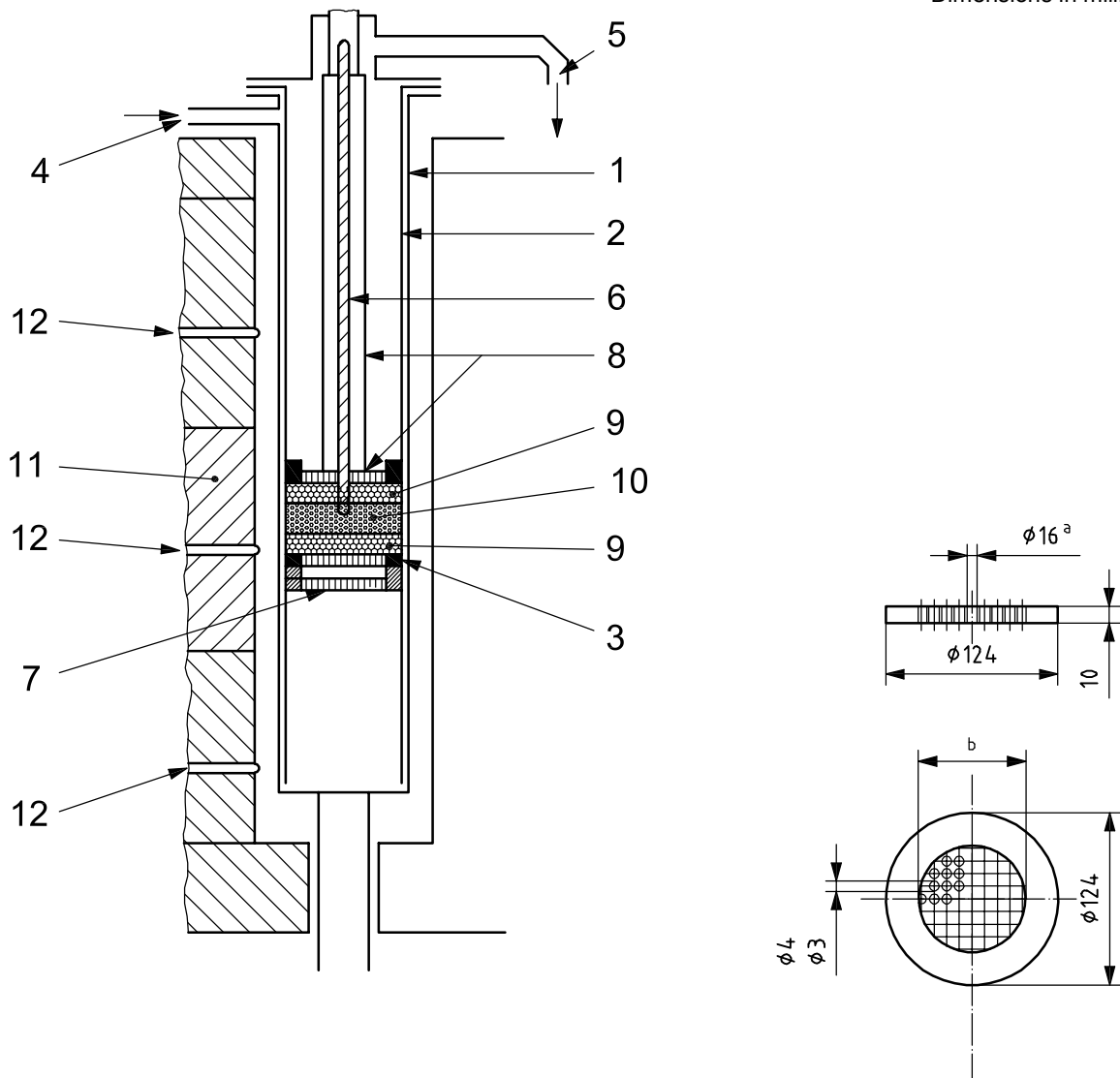

Key

Reduction tube

- 1 outer reduction tube
- 2 inner reduction tube (\varnothing 125 mm)
- 3 removable perforated plate
- 4 opening for gas inlet
- 5 opening for gas outlet
- 6 thermocouple for measuring the reduction temperature
- 7 perforated support
- 8 loading ram with rigid perforated footplate
- 9 porcelain balls (2 layers)
- 10 test portion (1 200 g)
- 11 furnace wall
- 12 furnace-wall thermocouples (upper, medial and lower)

a \varnothing 16 for thermocouple entrance.

b 14 holes \times 5 or 6 pitch.

NOTE Key numbers do not coincide with the ones in Figures 1 and 3

Figure 2 — Example of a reduction tube (schematic diagram)

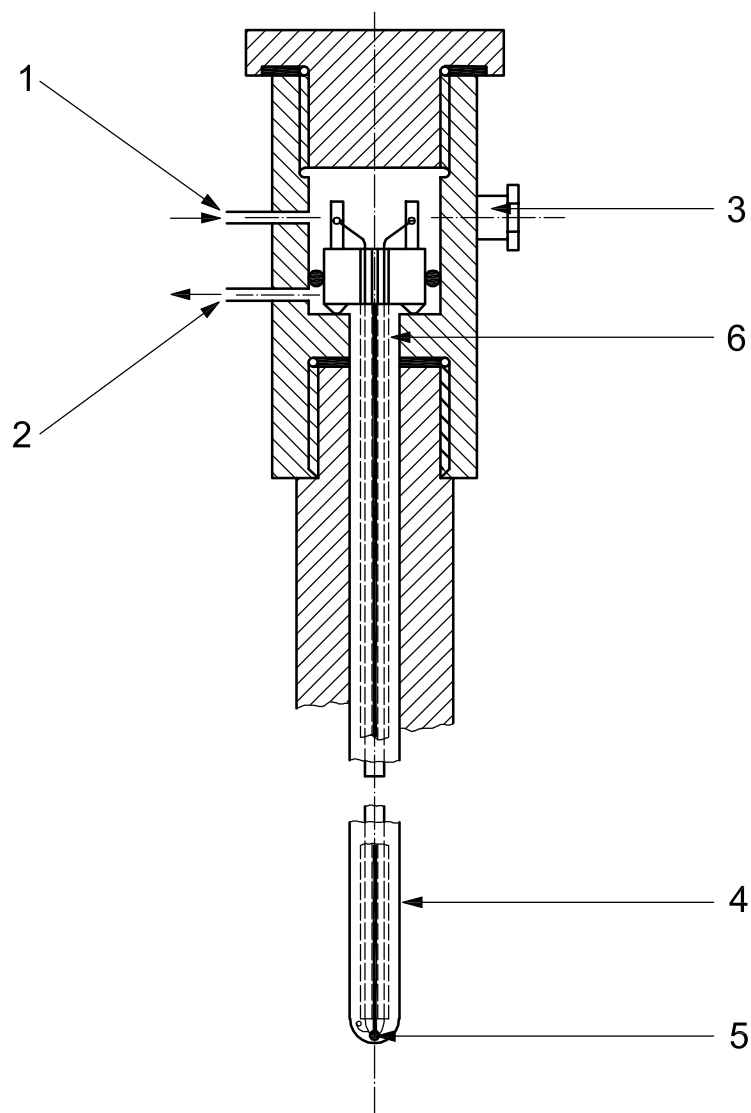

Key

- 1 oxygen inlet
- 2 oxygen outlet
- 3 thermocouple exit
- 4 protective tube
- 5 thermocouple tip
- 6 inner tube with four borings

NOTE Key numbers do not coincide with the ones in Figures 1 and 2.

Figure 3 — Principle of oxygen flushing of thermocouples to avoid mismeasurement due to carbon deposition

Annex A (normative)

Flowsheet of the procedure for the acceptance of test results

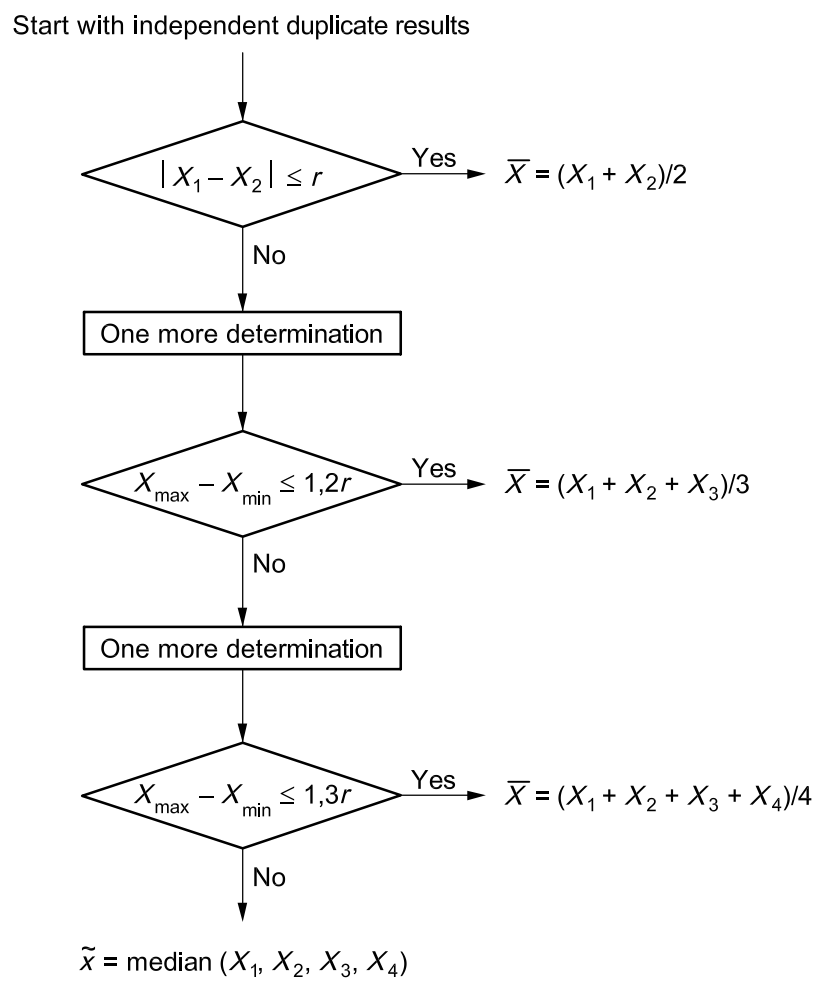

r : see 9.4

Annex B (informative)

Derivation of equation for reducibility

The “Degree of reduction” describes the extent to which oxygen has been removed from iron oxides, and is defined generally as shown below:

$$\text{Degree of reduction} = \frac{\text{oxygen removed from iron oxide}}{\text{original oxygen combined with iron}} \quad (\text{B.1})$$

The equation in 8.3 is derived on the assumption that all oxygen combined with iron is present in the form of hematite (Fe_2O_3), whereas, for most iron ore materials, some magnetite (Fe_3O_4), wustite (FeO), and metallic iron is also present. Therefore, the degree of reduction is estimated from the loss in mass of the test portion during reduction plus the difference between the theoretical oxygen content of the original sample, based on all iron being associated as Fe_2O_3 , and the true oxygen content based on actual amounts of Fe_2O_3 , Fe_3O_4 and FeO in the sample.

$$R_t = \frac{m_0 w_1 \times \frac{8}{71,85}}{m_0 w_2 \times \frac{48}{111,7}} \times 100 + \frac{m_1 - m_t}{m_0 \times \frac{w_2}{100} \times \frac{48}{111,7}} \times 100 \quad (\text{B.2})$$

.....

www.iso.org

ICS 73.060.10

Price based on 12 pages