

# Bolts — Test methods

## National foreword

This British Standard has been prepared under the direction of the Aerospace Standards Policy Committee. It is identical with ISO 7961 : 1994 *Aerospace — Bolts — Test methods*, published by the International Organization for Standardization (ISO).

**Cross-reference.** The Technical Committee has reviewed the provisions of ISO 7500-1 : 1986, to which normative reference is made in the text, and has decided that they are acceptable for use in conjunction with this standard.

**Compliance with a British Standard does not of itself confer immunity from legal obligations.**

---

# Contents

	Page
National foreword	Inside front page
Committees responsible	Back page
<hr/>	
<b>Method</b>	
1 Scope	1
2 Normative references	1
3 Tests	1
4 Test validity	12
5 Test reports	12
<hr/>	
<b>Annexes</b>	
A (normative) Calibration of apparatus	13
B (normative) Test reports	14
C (informative) Formulae	15
<hr/>	
<b>Tables</b>	
1 Rates of load application — Tensile test	4
2 Rates of load application — Double shear test	7
B.1 Information to appear in test report	14
<hr/>	
<b>Figures</b>	
1 Tensile test — Test device	2
2 Tensile test — Position of the nut in relation to the complete threads (shank side)	2
3 Tensile test — Upper and lower cup details	3
4 Double shear test — Test device	5
5 Double shear test — Upper and lower blocks	6
6 Stress corrosion test — Test cylinder (principle)	11

# Aerospace — Bolts — Test methods

## 1 Scope

This International Standard specifies test methods for bolts for aerospace constructions.

It is applicable whenever quoted in reference.

## 2 Normative reference

The following standard contains provisions which, through reference in this text, constitute provisions of this International Standard. At the time of publication, the edition indicated was valid. All standards are subject to revision, and parties to agreements based on this International Standard are encouraged to investigate the possibility of applying the most recent edition of the standard indicated below. Members of IEC and ISO maintain registers of currently valid International Standards.

ISO 7500-1:1986, *Metallic materials — Verification of static uniaxial testing machines — Part 1: Tensile testing machines*.

## 3 Tests

### 3.1 Tensile test at ambient temperature

#### 3.1.1 Apparatus

##### 3.1.1.1 Test device (see figure 1).

The test device shall be centred such that the stress at four equi-spaced points around the test sample is uniform within 1 %, or such that the coaxiality between the bolt and the clearance holes is less than or equal to 0,025 mm to ensure the application of the tensile load along the axis of the bolt<sup>1)</sup>.

Other types of device may be used provided they respect the requirements of figure 3.

**3.1.1.1.1 Cups**, fixed or removable, in conformity with figure 3, which specifies only functional requirements.

**3.1.1.1.2 Test nut** (free-running or self-locking) or **threaded part** (assuming the role of a nut), of sufficient strength to guarantee bolt failure.

**3.1.1.2 Tapered spacer**, placed under the head during the test, when required by the procurement specification or definition document to evaluate the effect of angularity. The minimum clearance between the hole and the bolt shank shall be 0,13 mm. At least 90 % of the bolt bearing area shall be supported by the spacer which shall have a diameter sufficient to support the width across the corners of the bolt. The tolerance on the hole diameter in the spacer shall be  $\begin{matrix} +0,08 \\ 0 \end{matrix}$  mm.

**3.1.1.3 Washers**, used under bolt heads or nuts only in the case outlined in 3.1.1.2.

**3.1.1.4 Tensile or compressive test machine**, depending on the fixture, capable of applying the test loads.

#### 3.1.2 Procedure

**3.1.2.1** Assemble the bolt in the test device (3.1.1.1) as shown in figure 1. Install the nut (3.1.1.1.2) as shown in figure 2. Place the complete assembly between the loading platens of the machine.

**3.1.2.2** Apply the load specified in the procurement specification or definition document at the rate specified in table 1<sup>1)</sup>, in a controlled way.

1) Calibration requirements: see ISO 7500-1:1986 and annex A of this International Standard.

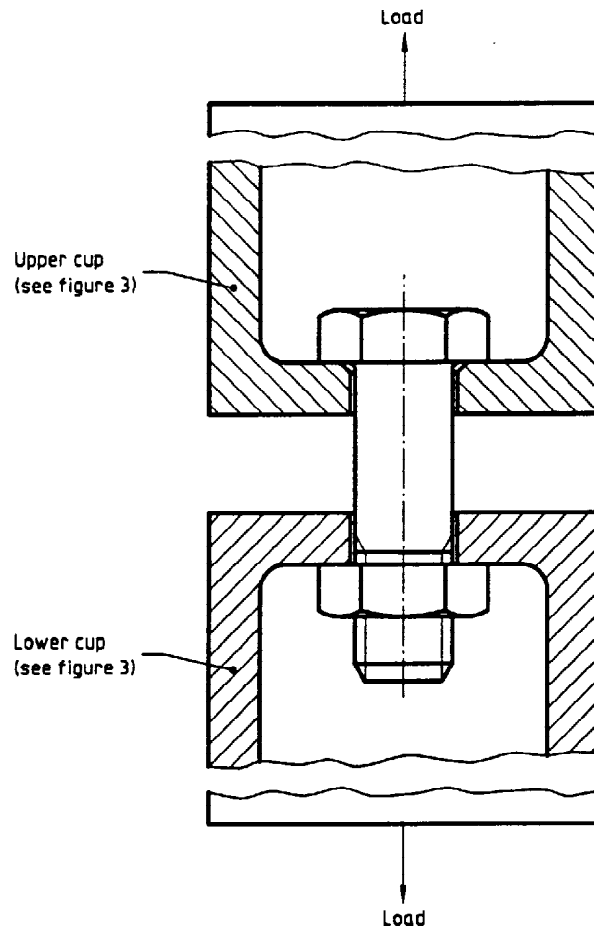

Figure 1 — Tensile test — Test device

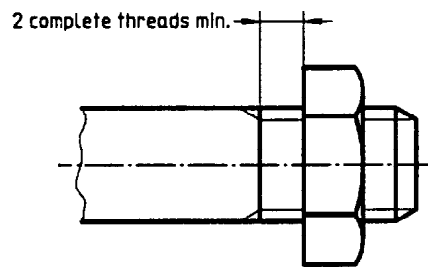
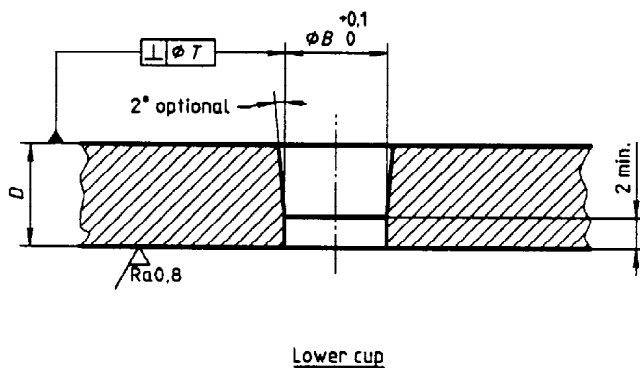
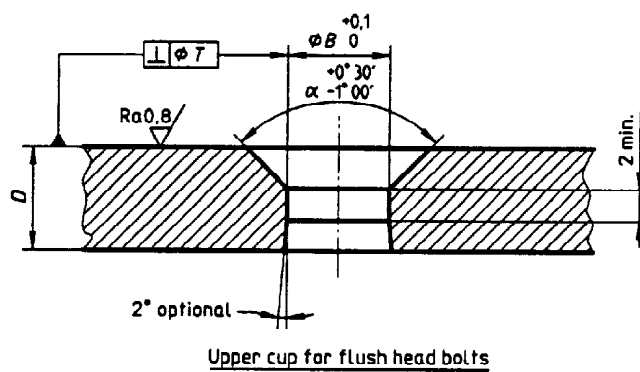
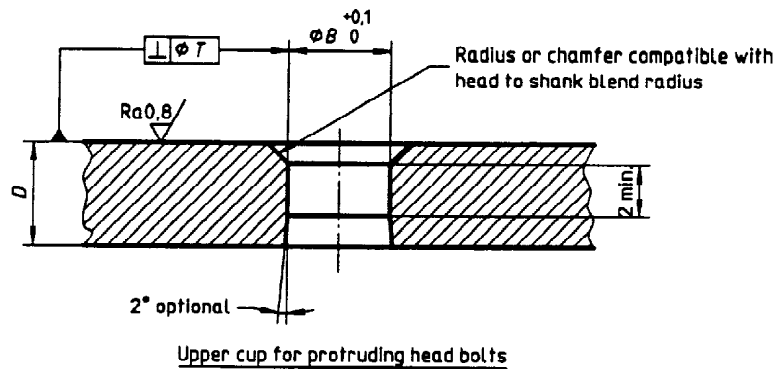

Figure 2 — Tensile test — Position of the nut in relation to the complete threads (shank side)

Dimensions in millimetres,  
surface roughness in micrometres



$$B \text{ nom.} = D + 0,025$$

$D$  = Nominal diameter of bolt

$T$  = Perpendicularity tolerance corresponding to  $2^\circ$

$\alpha$  = Nominal angle of countersunk head

Break sharp edges

Material: Steel of hardness  $> 43$  HRC

**Figure 3 — Tensile test — Upper and lower cup details**

Table 1 — Rates of load application — Tensile test

Nominal shank diameter <sup>1)</sup>	Rate kN/min	Nominal shank diameter <sup>1)</sup>	Rate kN/min	Nominal shank diameter <sup>1)</sup>	Rate kN/min
3	5	12	80	27	400
4	9	14	110	30	500
5	14	16	140	33	600
6	20	18	180	36	700
7	27	20	220	39	850
8	35	22	270		
10	55	24	320		

1) For other shank diameters, bolts shall be tested at a loading rate, accurate to  $\pm 10\%$ , of 750 N per minute per 1 mm<sup>2</sup> of nominal shank cross-section.

### 3.2 Double shear test

#### 3.2.1 Apparatus

See figures 4 and 5, the latter only defining functional requirements.

NOTE 1 Totally enclosed top and bottom blades may be used as an alternative.

#### 3.2.2 Procedure

**3.2.2.1** Assemble the bolt into the lower part of the guillotine. The blend radius under the head and the threaded portion shall not be in contact with the lower part of the guillotine (see figure 4).

**3.2.2.2** Apply the load required in the procurement specification or definition document at the rate specified in table 2, in a controlled way.

If this load is attained without breakage of the bolt, the test may be terminated<sup>1)</sup>.

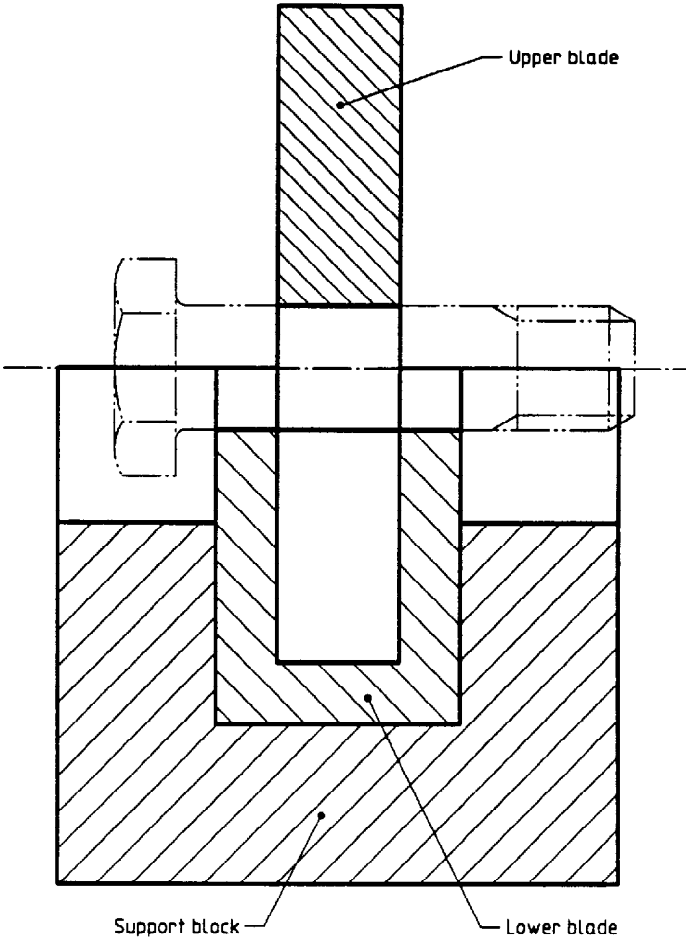
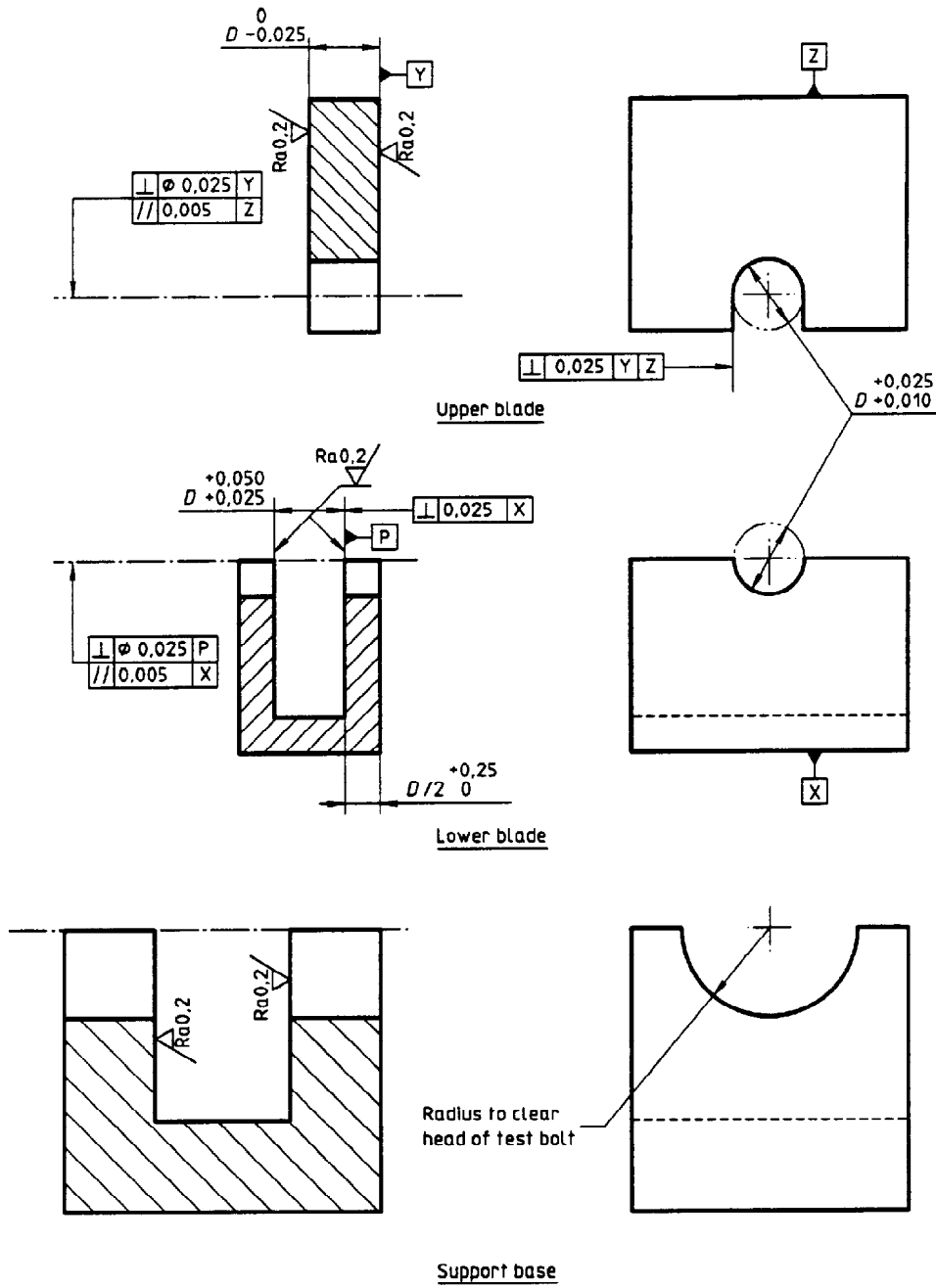

Figure 4 — Double shear test — Test device



Dimensions in millimetres,  
surface roughness in micrometres



Shear edges radius or break edge 0,13 max.

Rework when edges reach a radius of or break edge of 0,25 max.

$D$  = Nominal diameter of the bolt

Material: Steel of hardness 60 HRC to 62 HRC

**Figure 5 — Double shear test — Upper and lower blocks**

**Table 2 — Rates of load application — Double shear test**

Nominal shank diameter <sup>1)</sup>	Rate kN/min	Nominal shank diameter <sup>1)</sup>	Rate kN/min	Nominal shank diameter <sup>1)</sup>	Rate kN/min
3	10	12	160	27	800
4	18	14	215	30	990
5	27	16	280	33	1 200
6	40	18	350	36	1 400
7	54	20	440	39	1 700
8	70	22	530		
10	110	24	630		

1) For other shank diameters, bolts shall be tested at a loading rate, accurate to  $\pm 10\%$ , of 750 N per minute per 1 mm<sup>2</sup> of double the nominal shank cross-section.

### 3.3 Tension fatigue test

#### 3.3.1 Apparatus

##### 3.3.1.1 Test device (see figure 1).

Universal joints and spherical seats shall not be used in the test column. The test device shall be centred such that the stress at four equi-spaced points around the test sample shall be uniform within 3 % of the mean stress value<sup>1)</sup>.

Other types of device may be used provided they respect the requirements of figure 3.

Test bolts shall not be re-used.

**3.3.1.1.1 Cups**, fixed or removeable, in conformity with figure 3, which specifies only functional requirements.

**3.3.1.1.2 Test nut or threaded part** (assuming the role of a nut), with a height greater than or equal to  $0,8D$  and of sufficient strength to ensure bolt breakage.

NOTE 2 Test nuts or threaded parts may be re-used provided that it meets the dimensional requirements and has not been damaged by a previous test.

For referee purposes, only unused nuts or threaded parts shall be used.

**3.3.1.2 Load measuring system**, of an accuracy within  $\pm 2\%$  of the applied maximum load<sup>1)</sup>.

**3.3.1.3 Automatic load maintaining system.**

**3.3.1.4 Fixtures**, designed to incorporate the features indicated in figure 3.

#### 3.3.2 Procedure

##### 3.3.2.1 Installation

Test bolts shall be assembled so that a minimum of two and a maximum of three complete threads are exposed between the nut or threaded part (3.3.1.1.2) bearing face and incomplete threads on the shank side.

In the case of flush head bolts, the bearing between the bolt head and the loading cup in which it is to be tested shall be uniform.

There shall be no contact in the head-shank junction area.

##### 3.3.2.2 Test conditions

###### 3.3.2.2.1 Torque

There shall be no tensile stress due to torque or any other installation procedure.

###### 3.3.2.2.2 Load level

The fatigue test loads shall comply with the values specified in the procurement specification or definition document.

###### 3.3.2.2.3 Frequency

The frequency of the test shall conform with the requirements of the procurement specification or definition document. The maximum temperature of the bolt during test shall not exceed 50 °C.

### 3.4 Stress durability test of ambient temperature

#### 3.4.1 Apparatus

##### 3.4.1.1 For torque or elongation loading

**3.4.1.1.1 Steel blocks or spacers**, heat treated to obtain a minimum Rockwell hardness of 45 HRC.

**3.4.1.1.2 Threaded part**, with sufficient strength to withstand the full tensile strength of the bolt being tested.

##### 3.4.1.2 For external loading

**3.4.1.2.1 Test device**, as specified in 3.1.1.1.

**3.4.1.2.2 Adapted fixture<sup>1)</sup>**.

#### 3.4.2 Procedure

Assemble the bolt in the test device (3.4.1.2.1) and apply the load specified in the procurement specification or definition document.

For the torque loading method, the load is achieved by torque tightening to a pre-determined torque; this torque may be determined by formula or by calibrating torque against a load cell assimilating the test assembly<sup>2)</sup>.

For the elongation loading method, the load is achieved by measuring bolt extension; this extension may be determined by formula or by calibrating extension against a load cell assimilating the test assembly<sup>2)</sup>.

During the test, the loaded portion of the bolt shank shall have two full threads exposed between the incomplete threads on the shank side and the bearing face of the threaded part. Keep the bolt at ambient temperature in the loaded condition for the period of time specified in the procurement specification or definition document.

At the end of this time, disassemble and examine the bolt for the presence of cracks.

Bolts suspected of having cracks shall be sectioned and microscopically examined using  $\times 100$  magnification.

Cracked or fractured test bolts constitute failure of the bolt.

2) Formulae: see annex C.

### 3.5 Inspection for grinding burns

#### 3.5.1 Procedure

##### 3.5.1.1 Clean

Remove all foreign matter from the bolts such as grease, dirt or oxide film.

##### 3.5.1.2 Wetting test

Rinse the bolts in cold water. If water breaks occur, reclean the bolts.

##### 3.5.1.3 "Nital" etch

Immerse the bolts for 2 min to 2,5 min in a 3 % (V/V) solution of nitric acid (relative density 1,38) in ethanol, at ambient temperature. Agitate the bath.

##### 3.5.1.4 Rinse

Rinse the bolts for at least 2 min in running water at a temperature below 25 °C.

##### 3.5.1.5 Bleaching

Immerse the bolts for 2 min to 2,5 min in a 5 % (V/V) solution of hydrochloric acid (relative density 1,18) in ethanol, at ambient temperature. Agitate the bath.

##### 3.5.1.6 Rinse

Rinse the bolts for 10 s to 30 s in running water at a temperature below 25 °C.

##### 3.5.1.7 Neutralization

Neutralization may be performed with either of the following baths:

###### 3.5.1.7.1 Ammonia solution

Immerse the bolts for 30 s to 60 s in a solution of 50 g/l of ammonia (relative density 0,90), at ambient temperature.

###### 3.5.1.7.2 Soda solution

Immerse the bolts for 30 s to 60 s in a solution of 50 g/l of soda at ambient temperature.

##### 3.5.1.8 Rinse

Rinse the bolts for 10 s to 30 s in running water at a temperature below 25 °C.

**3.5.1.9 Dry**

Dry the bolts with filtered compressed air at ambient temperature.

**3.5.1.10 Examine for grinding burns**

These burns appear as either white streaks (untempered martensite) or dark grey (zone of overtempering) on an even light grey background on the surface of the bolts.

**3.5.1.11 De-embrittle**

Carry out a maximum of 12 h of "Nital" etch (3.5.1.3) de-embrittlement treatment on the bolts at a temperature of  $130\text{ °C} \pm 10\text{ °C}$  or  $190\text{ °C} \pm 10\text{ °C}$  for at least 2 h, depending on whether the tempering temperature of the parts is less than or equal to  $200\text{ °C}$  or greater than  $200\text{ °C}$ .

NOTE 3 After bleaching (3.5.1.5) and up to drying (3.5.1.9), operations should be carried out quickly to avoid oxidation. This oxidation builds up a chamois colour reducing contrast at a defect. Rinsing in running water at a temperature below  $25\text{ °C}$  produces a uniform light grey colour on bolts without grinding defects, instead of a chamois colour for higher temperatures.

**3.6 Tensile test at elevated temperature****3.6.1 Apparatus**

**3.6.1.1 Test device**, as specified in 3.1.1.1. Materials and dimensional tolerances shall be consistent with the temperature.

**3.6.1.2 Furnace**, in which regulation and thermocouples used shall determine, indicate and control the temperature of the bolt over its entire length within  $\pm 3\text{ °C}$  to  $1\ 260\text{ °C}$ <sup>1)</sup>.

Thermocouples shall

— have the following accuracy:

$\pm 1\text{ °C}$  from  $18\text{ °C}$  to  $276\text{ °C}$ ,

$\pm 0,4\%$  from  $277\text{ °C}$  to  $1\ 260\text{ °C}$ ;

— be fitted with ceramic insulators from 10 mm from the junction to 300 mm outside the furnace, and after, with an insulating material;

— have their hot spot clamped against the bolt so as not to be affected by the ambient conditions;

— be attached to each end of the bolt and, if possible, in the middle.

**3.6.1.3 Tensile or compressive test machine**, depending on the fixture, capable of applying the test loads.

**3.6.2 Procedure**

**3.6.2.1** Mount the bolt to be tested, fitted with its thermocouples, in the test device (3.6.1.1), and place this, with the furnace between the platens of the machine.

**3.6.2.2** Heat the furnace to the temperature specified in the procurement specification or definition document. The minimum time to reach this temperature shall be 60 min per 25 mm of bolt diameter.

**3.6.2.3** Maintain this temperature for 30 min before applying the load, then throughout the test.

**3.6.2.4** Apply the load specified in the procurement specification or definition document at the rate specified in table 1, in a controlled way.

**3.6.2.5** Record the bolt temperature for the full duration of the test.

**3.7 Stress relaxation test at elevated temperature****3.7.1 Apparatus**

**3.7.1.1 Test device**, as specified in 3.1.1.1. Materials and dimensional tolerances shall be consistent with the temperature.

**3.7.1.2 Tensile test machine**, capable of ensuring that the initial length of the bolt is maintained under load and to the nearest 0,005 mm. This shall be accomplished by means of an extensometer connected to a mechanism to apply or remove the load whenever the initial length changes by 0,005 mm<sup>1)</sup>.

The load applied to the bolt shall be measured within  $\pm 2\%$  and recorded.

**3.7.1.3 Furnace**, in which regulation and thermocouples used shall determine, indicate and control the temperature of the bolt over its entire length within  $\pm 3\text{ °C}$  to  $1\ 260\text{ °C}$ <sup>1)</sup>.

The thermocouples shall

— have the following accuracy:

$\pm 1\text{ °C}$  from  $18\text{ °C}$  to  $276\text{ °C}$ ,

$\pm 0,4\%$  from  $277\text{ °C}$  to  $1\ 260\text{ °C}$ ;

— be fitted with ceramic insulators from 10 mm of the junction to 300 mm outside the furnace, and after, with an insulating material;

- have their hot spot clamped against the bolt so as not to be affected by the ambient conditions;
- be attached to each end of the bolt, and if possible in the middle.

### 3.7.2 Procedure

**3.7.2.1** Mount the bolt to be tested, fitted with its thermocouples, in the test device (3.7.1.1), and place this, with the furnace (3.7.1.3), between the platens of the machine.

**3.7.2.2** Heat the furnace to the temperature specified in the procurement specification or definition document. The minimum time to reach this temperature shall be 60 min per 25 mm of bolt diameter.

**3.7.2.3** Maintain this temperature for 30 min before applying the load, then throughout the test.

**3.7.2.4** Apply the load specified in the procurement specification or definition document.

**3.7.2.5** Maintain the test temperature and bolt length, and record load against time for the specified test duration. Plot the stress relaxation curve. Use the tensile stress area values specified in the bolt procurement specification or definition document to calculate the stress from the recorder load values.

**3.7.2.6** Record the bolt temperature for the full duration of the test.

## 3.8 Stress corrosion test

**CAUTION — It is recommended to take safety precautions to protect from explosive fracture of the test bolt.**

### 3.8.1 Apparatus

**3.8.1.1 Test cylinders**, in conformity with figure 6 which only specifies functional requirements, unless otherwise specified in the procurement specification or definition document. They may only be re-used if they are undamaged and completely free from corrosive products.

The materials of the companion test nut and cylinders shall be those specified in the procurement specification or definition document or of galvanic compatibility with the bolt tested.

**3.8.1.2 Measuring instrument**, capable of showing variations in bolt length of 10  $\mu\text{m}$  with an accuracy of 2,5  $\mu\text{m}$ .

**3.8.1.3 Alternate immersion-emersion device**, permitting 10 min  $\pm$  1 min of immersion in the salt solution, of the bolt fitted in the test cylinder (3.8.1.1), and emersion, for drying in circulating air during the remainder of the 60 min cycle. The racks supporting the test bolt assembly shall not contact the salt solution.

The materials of the test chamber and accessories shall not affect the test conditions.

The vented atmosphere of the test chamber shall be

- free from oil and dust;
- maintained at 24 °C  $\pm$  3 °C;
- sufficient to dry test samples completely in 50 min.

### 3.8.1.4 Salt solution,

- having a controlled and maintained content of 3,5 % (m/m)  $\pm$  0,5 % (m/m) of sodium chloride with not more than 0,01 % sodium iodide and not more than 0,3 % total impurities;
- prepared from distilled or deionized water with not more than 200 ppm of total chlorides;
- having a pH maintained between 6,5 and 7,5, controlled every 24 h and adjusted with chemically pure dilute hydrochloric acid or sodium hydroxide;
- to be used for only for one type of bolt alloy;
- to be changed at least every 7 days.

### 3.8.2 Procedure

**3.8.2.1** Prepare the ends of the test bolt so that its length can be measured accurately on a repeated basis.

**3.8.2.2** Clean the bolts to be tested with non-chlorinated solvents until the surface is free of water break.

After cleaning there shall be minimum handling with clean lintless gloves.

**3.8.2.3** Insert the bolt to be tested into the test cylinder (3.8.1.1), fit the companion nut and tighten manually. A minimum of two full threads shall extend beyond the nut.

Measure the overall length of the bolt.

Torque tighten the nut producing 75 % of the minimum specified strength of the bolt, using torque, load and elongation comparison curves.

Seal the ends of the test bolt to avoid corrosion.

Dimensions in millimetres,  
surface roughness in micrometres

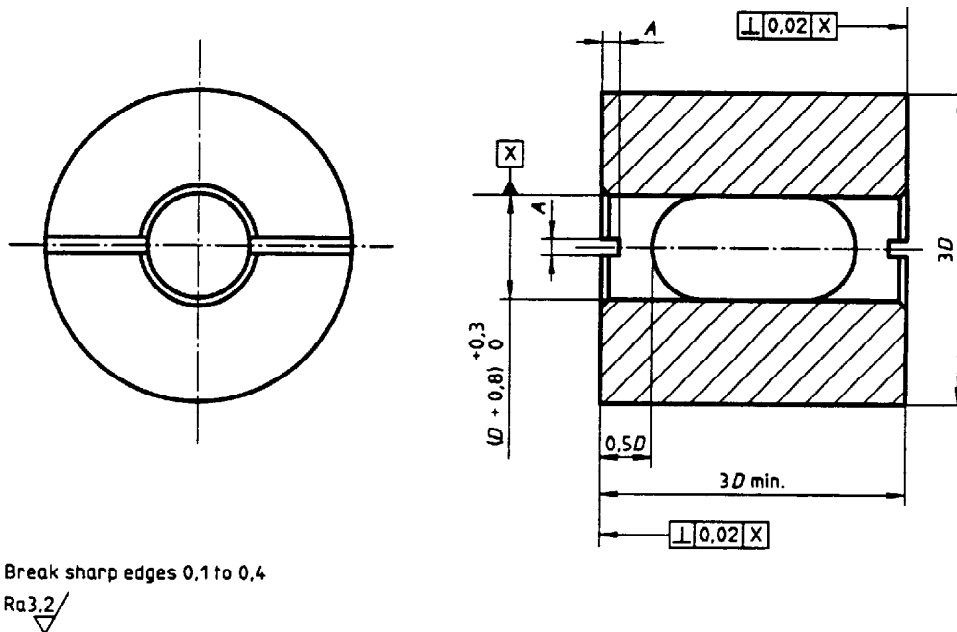

$D$  = Nominal diameter of the bolt

$A = (R + 0,8) \pm 0,25$  limited to 1,5 min.

$R$  = Radius under bolt head

Material and thermic treatment: see 3.8.1.1

**Figure 6 — Stress corrosion test — Test cylinder (principle)**

**3.8.2.4** Reclean the bolt nut, cylinder assembly then suspend it from the immersion-emersion arm using a non-metallic cord or hook to avoid

- all contact with metallic materials;
- any transfer of corrosion products and condensation between test cylinders;

and to ensure drying of the exposed parts of the bolt during emersion.

**3.8.2.5** Start and repeat the immersion-emersion cycle (see 3.8.1.3) until the failure of the bolt, or for the specified time, examining the bolts with the naked eye every 24 h and at the end of the test to ascertain any indications of cracks or fracture.

### 3.9 Stress rupture test at elevated temperature

#### 3.9.1 Apparatus

**3.9.1.1 Test device**, as specified in 3.1.1.1. Materials and dimensional tolerances shall be consistent with the temperature.

**3.9.1.2 Tensile test machine**, capable of loading and maintaining the constant load and within the limits specified in the procurement specification or definition document to an accuracy of 1 % for the entire range of test loads<sup>1)</sup>.

**3.9.1.3 Furnace**, in which regulation and thermocouples used shall determine, indicate and control the temperature of the bolt over its entire length within  $\pm 3$  °C to 1 260 °C<sup>1)</sup>.

The thermocouples shall

— have the following accuracy:

$\pm 1$  °C from 18 °C to 276 °C,

$\pm 0,4$  % from 277 °C to 1 260 °C;

— be fitted with ceramic insulators from 10 mm from the junction to 300 mm outside the furnace, and after, with an insulating material;

— have their hot spot clamped against the bolt so as not to be affected by the ambient conditions;

— be attached to each end of the bolt and, if possible, in the middle.

**3.9.1.4 Time recorder**, with an accuracy of  $\pm 1$  %.

#### 3.9.2 Procedure

**3.9.2.1** Fit the bolt to be tested, previously cleaned in a nonchloride solvent, in the test device (3.9.1.1) then place the assembly between the platens of the machine.

**3.9.2.2** Attach the thermocouples to the bolt to be tested in accordance with 3.9.1.3.

**3.9.2.3** Attain and maintain, at the test temperature specified in the procurement specification or definition document, for at least 30 min to ensure thermic balance and a uniform temperature of the bolt to be tested.

**3.9.2.4** Apply the test load specified in the procurement specification or definition document, in 1 min, without either shock or overload.

**3.9.2.5** Maintain the load and the temperature for the remainder of the specified test duration, or if it occurs beforehand, until the fracture of the bolt under test.

### 4 Test validity

All tests leading to a result which does not conform with the requirements of the procurement specification or definition document, but not attributable to the bolt being tested, shall not be considered as valid or useful. The test shall be repeated.

### 5 Test reports

Test reports shall contain the relevant information specified in annex B.

**Annex A**  
(normative)

**Calibration of apparatus**

- A.1** Calibration with the exception of the fatigue machine shall be carried out periodically and at least every 12 months.
- A.2** Fatigue machines shall be calibrated dynamically at installation and also when load cells and/or amplifiers are changed. They shall be calibrated statically every 1 000 functional hours, or every 6 months.
- A.3** Calibration shall be conducted by a National official body or an organisation controlled by such a body.



## Annex B (normative)

### Test reports

For each test, the report shall contain the information specified in table B.1.

**Table B.1 — Information to appear in test report**

Parameters	Tensile test at ambient temperature	Double shear test	Tension fatigue test	Stress durability test at ambient temperature	Inspection for grinding burns	Tensile test at elevated temperature	Stress relaxation test at elevated temperature	Stress corrosion test	Stress rupture test at elevated temperature
Part number	x	x	x	x	x	x	x	x	x
Batch identity	x	x	x	x	x	x	x	x	x
Manufacturer	x	x	x	x	x	x	x	x	x
Material	x	x	x	x	x	x	x	x	x
Procurement specification or definition document reference	x	x	x	x	x	x	x	x	x
Test load				x		x	x		x
Breaking load	x	x				x			x
Position of failure	x		x			x			
Test duration							x	x	
Time/cycles to failure			x				x	x	
Test temperature						x	x		
Initial bolt length							x		
Bolt elongation									x
Decision	x	x	x	x	x	x	x	x	x

## Annex C (informative)

### Formulae

#### C.1 Estimated torque to induce specified load

$$T = 0,001KDF$$

where

- $T$  is the torque, in newton metres;  
 $K = 0,1$  (friction factor);  
 $D$  is the nominal diameter of test bolt, in millimetres;  
 $F$  is the induced load, in newtons.

where

- $e$  is the total bolt elongation, in millimetres;  
 $F$  is the induced load, in newtons;  
 $E$  is the modulus of elasticity for the material of the test bolt, in gigapascals;  
 $L$  is the length of grip, in millimetres;  
 $A$  is the cross-sectional area of bolt shank, in square millimetres;  
 $L_t$  is the thread length between bearing faces, in millimetres;  
 $A_t$  is the tensile stress area of thread (specified in the bolt procurement specification or definition document), in square millimetres.

#### C.2 Estimated elongation to induce specified load

$$e = 0,001 \times \frac{F}{E} \left( \frac{L}{A} + \frac{L_t}{A_t} \right)$$

---

## List of references

See national foreword.

---

---

## **Committees responsible for this British Standard**

The preparation of this British Standard was entrusted by the Aerospace Standards Policy Committee (ACE/-) to Technical Committee ACE/12, upon which the following bodies were represented:

The Association of Electronics, Telecommunications and Business Equipment  
Industries  
British Industrial Fasteners Federation  
Ministry of Defence  
Society of British Aerospace Companies Ltd.

This British Standard, having been prepared under the direction of the Aerospace Standards Policy Committee, was published under the authority of the Standards Board and comes into effect on 15 August 1994

© BSI 1994

The following BSI references relate to the work on this standard:  
Committee reference ACE/12  
Draft for comment 91/82709 DC

ISBN 0 580 23219 0

### **Amendments issued since publication**

<b>Amd. No.</b>	<b>Date</b>	<b>Text affected</b>

**BSI, 2 Park Street, London W1A 2BS**

**BSI, Linford Wood, Milton Keynes MK14 6LE**