**Hydrodynamic plain journal bearings
under steady-state conditions —
Circular cylindrical bearings —**

**Part 1:
Calculation procedure**

*Paliers lisses hydrodynamiques radiaux fonctionnant en régime
stabilisé — Paliers circulaires cylindriques —*

Partie 1: Méthode de calcul





COPYRIGHT PROTECTED DOCUMENT

© ISO 2013

All rights reserved. Unless otherwise specified, no part of this publication may be reproduced or utilized otherwise in any form or by any means, electronic or mechanical, including photocopying, or posting on the internet or an intranet, without prior written permission. Permission can be requested from either ISO at the address below or ISO's member body in the country of the requester.

ISO copyright office
Case postale 56 • CH-1211 Geneva 20
Tel. + 41 22 749 01 11
Fax + 41 22 749 09 47
E-mail copyright@iso.org
Web www.iso.org

Published in Switzerland

Contents

	Page
Foreword	iv
1 Scope	1
2 Normative references	1
3 Basis of calculation, assumptions, and preconditions	1
4 Calculation procedure	3
5 Symbols and units	5
6 Definition of symbols	6
6.1 Load-carrying capacity	6
6.2 Frictional power loss	9
6.3 Lubricant flow rate	10
6.4 Heat balance	11
6.5 Minimum lubricant film thickness and specific bearing load	13
6.6 Operational conditions	14
6.7 Further influencing factors	15
Annex A (normative) Calculation examples	17
Bibliography	32

Foreword

ISO (the International Organization for Standardization) is a worldwide federation of national standards bodies (ISO member bodies). The work of preparing International Standards is normally carried out through ISO technical committees. Each member body interested in a subject for which a technical committee has been established has the right to be represented on that committee. International organizations, governmental and non-governmental, in liaison with ISO, also take part in the work. ISO collaborates closely with the International Electrotechnical Commission (IEC) on all matters of electrotechnical standardization.

The procedures used to develop this document and those intended for its further maintenance are described in the ISO/IEC Directives, Part 1. In particular the different approval criteria needed for the different types of ISO documents should be noted. This document was drafted in accordance with the editorial rules of the ISO/IEC Directives, Part 2. www.iso.org/directives.

Attention is drawn to the possibility that some of the elements of this document may be the subject of patent rights. ISO shall not be held responsible for identifying any or all such patent rights. Details of any patent rights identified during the development of the document will be in the Introduction and/or on the ISO list of patent declarations received. www.iso.org/patents.

Any trade name used in this document is information given for the convenience of users and does not constitute an endorsement.

The committee responsible for this document is ISO/TC 123, *Plain bearings*, Subcommittee SC 4, *Methods of calculation of plain bearings*.

This second edition cancels and replaces the first edition (ISO 7902-1:1998), which has been technically revised.

ISO 7902 consists of the following parts, under the general title *Hydrodynamic plain journal bearings under steady-state conditions — Circular cylindrical bearings*:

- *Part 1: Calculation procedure*
- *Part 2: Functions used in the calculation procedure*
- *Part 3: Permissible operational parameters*

Hydrodynamic plain journal bearings under steady-state conditions — Circular cylindrical bearings —

Part 1: Calculation procedure

1 Scope

This part of ISO 7902 specifies a calculation procedure for oil-lubricated hydrodynamic plain bearings, with complete separation of the shaft and bearing sliding surfaces by a film of lubricant, used for designing plain bearings that are reliable in operation.

It deals with circular cylindrical bearings having angular spans, Ω , of 360°, 180°, 150°, 120°, and 90°, the arc segment being loaded centrally. Their clearance geometry is constant except for negligible deformations resulting from lubricant film pressure and temperature.

The calculation procedure serves to dimension and optimize plain bearings in turbines, generators, electric motors, gear units, rolling mills, pumps, and other machines. It is limited to steady-state operation, i.e. under continuously driven operating conditions, with the magnitude and direction of loading as well as the angular speeds of all rotating parts constant. It can also be applied if a full plain bearing is subjected to a constant force rotating at any speed. Dynamic loadings, i.e. those whose magnitude and direction vary with time, such as can result from vibration effects and instabilities of rapid-running rotors, are not taken into account.

2 Normative references

The following documents, in whole or in part, are normatively referenced in this document and are indispensable for its application. For dated references, only the edition cited applies. For undated references, the latest edition of the referenced document (including any amendments) applies.

ISO 3448, *Industrial liquid lubricants — ISO viscosity classification*

ISO 7902-2:1998, *Hydrodynamic plain journal bearings under steady-state conditions — Circular cylindrical bearings — Part 2: Functions used in the calculation procedure*

ISO 7902-3, *Hydrodynamic plain journal bearings under steady-state conditions — Circular cylindrical bearings — Part 3: Permissible operational parameters*

3 Basis of calculation, assumptions, and preconditions

3.1 The basis of calculation is the numerical solution to Reynolds' differential equation for a finite bearing length, taking into account the physically correct boundary conditions for the generation of pressure:

$$\frac{\partial}{\partial x} \left(h^3 \frac{\partial p}{\partial x} \right) + \frac{\partial}{\partial x} \left(h^3 \frac{\partial p}{\partial z} \right) = 6\eta(u_J + u_B) \frac{\partial h}{\partial x} \quad (1)$$

The symbols are given in [Clause 5](#).

See References [1] to [3] and References [11] to [14] for the derivation of Reynolds' differential equation and References [4] to [6], [12], and [13] for its numerical solution.

3.2 The following idealizing assumptions and preconditions are made, the permissibility of which has been sufficiently confirmed both experimentally and in practice.

- a) The lubricant corresponds to a Newtonian fluid.
- b) All lubricant flows are laminar.
- c) The lubricant adheres completely to the sliding surfaces.
- d) The lubricant is incompressible.
- e) The lubricant clearance gap in the loaded area is completely filled with lubricant. Filling up of the unloaded area depends on the way the lubricant is supplied to the bearing.
- f) Inertia effects, gravitational and magnetic forces of the lubricant are negligible.
- g) The components forming the lubrication clearance gap are rigid or their deformation is negligible; their surfaces are ideal circular cylinders.
- h) The radii of curvature of the surfaces in relative motion are large in comparison with the lubricant film thicknesses.
- i) The lubricant film thickness in the axial direction (z -coordinate) is constant.
- j) Fluctuations in pressure within the lubricant film normal to the bearing surfaces (y -coordinate) are negligible.
- k) There is no motion normal to the bearing surfaces (y -coordinate).
- l) The lubricant is isoviscous over the entire lubrication clearance gap.
- m) The lubricant is fed in at the start of the bearing liner or where the lubrication clearance gap is widest; the magnitude of the lubricant feed pressure is negligible in comparison with the lubricant film pressures.

3.3 The boundary conditions for the generation of lubricant film pressure fulfil the following continuity conditions:

- at the leading edge of the pressure profile: $p(\varphi_1, z) = 0$;
- at the bearing rim: $p(\varphi, z = \pm B/2) = 0$;
- at the trailing edge of the pressure profile: $p[\varphi_2(z), z] = 0$;
- $\partial p / \partial \varphi [\varphi_2(z), z] = 0$.

For some types and sizes of bearing, the boundary conditions may be specified.

In partial bearings, if Formula (2) is satisfied:

$$\varphi_2 - (\pi - \beta) < \pi/2 \tag{2}$$

then the trailing edge of the pressure profile lies at the outlet end of the bearing:

$$p(\varphi = \varphi_2, z) = 0 \tag{3}$$

3.4 The numerical integration of the Reynolds' differential equation is carried out (possibly by applying transformation of pressure as suggested in References [3], [11], and [12]) by a transformation to a differential formula which is applied to a grid system of supporting points, and which results in a system of linear formulae. The number of supporting points is significant to the accuracy of the numerical

integration; the use of a non-equidistant grid as given in References [6] and [13] is advantageous. After substituting the boundary conditions at the trailing edge of the pressure profile, integration yields the pressure distribution in the circumferential and axial directions.

The application of the similarity principle to hydrodynamic plain bearing theory results in dimensionless magnitudes of similarity for parameters of interest, such as load-carrying capacity, frictional behaviour, lubricant flow rate, and relative bearing length. The application of magnitudes of similarity reduces the number of numerical solutions required of Reynolds' differential equation specified in ISO 7902-2. Other solutions may also be applied, provided they fulfil the conditions laid down in ISO 7902-2 and are of a similar numerical accuracy.

3.5 ISO 7902-3 includes permissible operational parameters towards which the result of the calculation shall be oriented in order to ensure correct functioning of the plain bearings.

In special cases, operational parameters deviating from ISO 7902-3 may be agreed upon for specific applications.

4 Calculation procedure

4.1 Calculation is understood to mean determination of correct operation by computation using actual operating parameters (see [Figure 1](#)), which can be compared with operational parameters. The operating parameters determined under varying operating conditions shall therefore lie within the range of permissibility as compared with the operational parameters. To this end, all operating conditions during continuous operation shall be investigated.

4.2 Freedom from wear is guaranteed only if complete separation of the mating bearing parts is achieved by the lubricant. Continuous operation in the mixed friction range results in failure. Short-time operation in the mixed friction range, for example starting up and running down machines with plain bearings, is unavoidable and does not generally result in bearing damage. When a bearing is subjected to heavy load, an auxiliary hydrostatic arrangement may be necessary for starting up and running down at a slow speed. Running-in and adaptive wear to compensate for deviations of the surface geometry from the ideal are permissible as long as they are limited in area and time and occur without overloading effects. In certain cases, a specific running-in procedure may be beneficial, depending on the choice of materials.

4.3 The limits of mechanical loading are a function of the strength of the bearing material. Slight permanent deformations are permissible as long as they do not impair correct functioning of the plain bearing.

4.4 The limits of thermal loading result not only from the thermal stability of the bearing material but also from the viscosity-temperature relationship and by degradation of the lubricant.

4.5 A correct calculation for plain bearings presupposes that the operating conditions are known for all cases of continuous operation. In practice, however, additional influences frequently occur, which are unknown at the design stage and cannot always be predicted. The application of an appropriate safety margin between the actual operating parameters and permissible operational parameters is recommended. Influences include, for example:

- spurious forces (out-of-balance, vibrations, etc.);

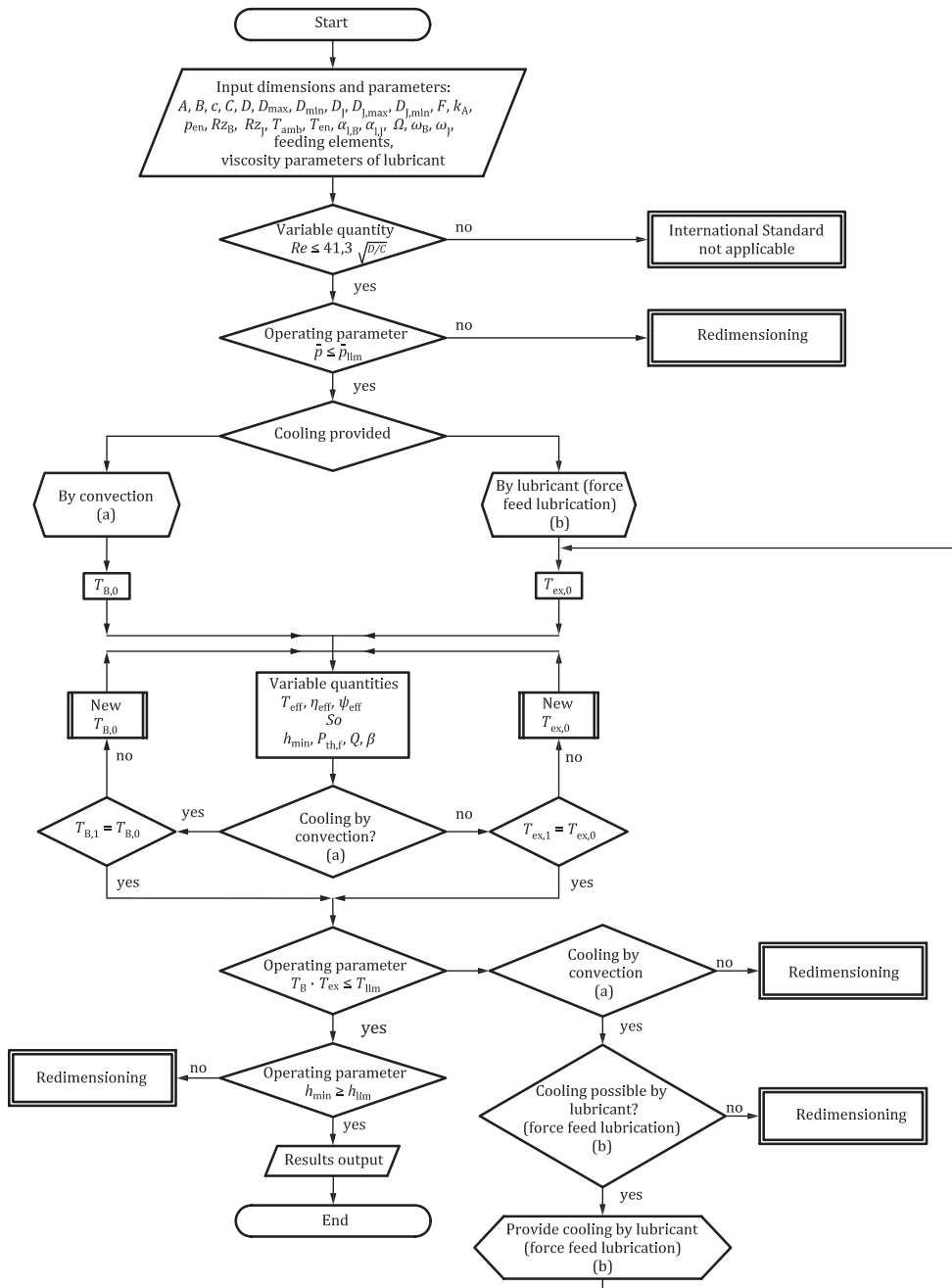

Figure 1 — Outline of calculation

- deviations from the ideal geometry (machining tolerances, deviations during assembly, etc.);
- lubricants contaminated by dirt, water, air, etc.;
- corrosion, electrical erosion, etc.

Data on other influencing factors are given in 6.7.

4.6 The Reynolds number shall be used to verify that ISO 7902-2, for which laminar flow in the lubrication clearance gap is a necessary condition, can be applied:

$$Re = \frac{\rho U_j \frac{C_{R,eff}}{2}}{\eta} = \frac{\pi D N_j \frac{C_{R,eff}}{2}}{\nu} \leq 41,3 \sqrt{\frac{D}{C_{R,eff}}} \quad (4)$$

In the case of plain bearings with $Re > 41,3 \sqrt{D/C_{R,eff}}$ (for example as a result of high peripheral speed), higher loss coefficients and bearing temperatures shall be expected. Calculations for bearings with turbulent flow cannot be carried out in accordance with this part of ISO 7902.

4.7 The plain bearing calculation takes into account the following factors (starting with the known bearing dimensions and operational data):

- the relationship between load-carrying capacity and lubricant film thickness;
- the frictional power rate;
- the lubricant flow rate;
- the heat balance.

All these factors are mutually dependent.

The solution is obtained using an iterative method; the sequence is outlined in the flow chart in [Figure 1](#).

For optimization of individual parameters, parameter variation can be applied; modification of the calculation sequence is possible.

5 Symbols and units

See [Figure 2](#) and [Table 1](#).

Minimum lubricant film thickness, h_{\min} :

$$h_{\min} = \frac{D - D_j}{2} - e = 0,5D\psi(1 - \varepsilon) \quad (5)$$

where the relative eccentricity, ε , is given by

$$\varepsilon = \frac{e}{\frac{D - D_j}{2}} \quad (6)$$

If

$$\varphi_2 - (\pi - \beta) < \frac{\pi}{2} \quad (7)$$

then

$$h_{\min} = 0,5D\psi(1 + \varepsilon \cos \varphi_2) \quad (8)$$

6 Definition of symbols

6.1 Load-carrying capacity

A characteristic parameter for the load-carrying capacity is the dimensionless Sommerfeld number, So :

$$So = \frac{F\psi_{\text{eff}}^2}{DB\eta_{\text{eff}}\omega_h} = So\left(\epsilon, \frac{B}{D}, \Omega\right) \tag{9}$$

Values of So as a function of the relative eccentricity, ϵ , the relative bearing length, B/D , and the angular span of bearing segment, Ω , are given in ISO 7902-2. The variables ω_h , η_{eff} , and ϕ_{eff} take into account the thermal effects and the angular velocities of shaft, bearing, and bearing force (see 6.4 and 6.7).

The relative eccentricity, ϵ , together with the attitude angle, β (see ISO 7902-2), describes the magnitude and position of the minimum thickness of lubricant film. For a full bearing ($\Omega = 360^\circ$), the oil should be introduced at the greatest lubricant clearance gap or, with respect to the direction of rotation, shortly before it. For this reason, it is useful to know the attitude angle, β .

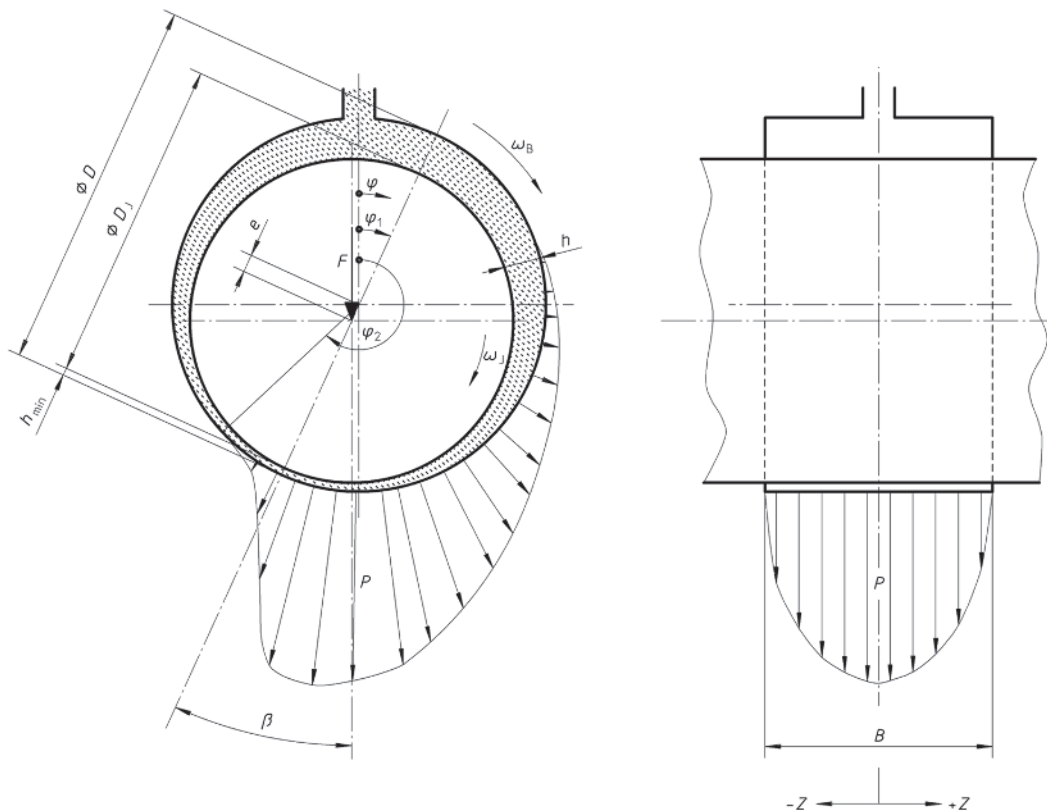

Figure 2 — Illustration of symbols

Table 1 — Symbols and their designations

Symbol	Designation	Unit
A	Area of heat-emitting surface (bearing housing)	m^2
b_G	Width of oil groove	m
B	Nominal bearing width	m
c	Specific heat capacity of the lubricant	$\text{J}/(\text{kg}\cdot\text{K})$
C	Nominal bearing clearance	m

Table 1 (continued)

Symbol	Designation	Unit
$C_{R,eff}$	Effective bearing radial clearance	m
d_L	Oil hole diameter	m
D	Nominal bearing diameter (inside diameter)	m
D_J	Nominal shaft diameter	m
$D_{J,max}$	Maximum value of D_J	m
$D_{J,min}$	Minimum value of D_J	m
D_{max}	Maximum value of D	m
D_{min}	Minimum value of D	m
e	Eccentricity between the axis of the shaft and the bearing axis	m
E	Modulus of elasticity	1
f	Coefficient of friction	1
F	Bearing force (nominal load)	N
F_f	Friction force in the loaded area of the lubricant film	N
F_f'	Frictional force in the unloaded area of the lubricant film	N
G	Shear modulus	1
h	Local lubricant film thickness	m
h_{lim}	Minimum permissible lubricant film thickness	m
h_{min}	Minimum lubricant film thickness	m
h_{wav}	Waviness of sliding surface	m
$h_{wav,eff}$	Effective waviness of sliding surface	m
$h_{wav,eff,lim}$	Maximum permissible effective waviness	m
k_A	Outer heat transmission coefficient	w/(m ² ·K)
l_G	Length of oil groove	m
l_p	Length of oil pocket	m
L_H	Length of bearing housing Rotational	m
N_B	Frequency of the bearing Rotational	s ⁻¹
N_F	Frequency of the bearing force Rotational	s ⁻¹
N_J	Frequency of the shaft	s ⁻¹
p	Local lubricant film pressure	Pa
\bar{p}	Specific bearing load	Pa
P_{en}	Lubricant feed pressure	Pa
p_{lim}	Maximum permissible lubricant film pressure	Pa
\bar{p}_{lim}	Maximum permissible specific bearing load	Pa
P_f	Frictional power	W
P_{th}	Heat flow rate	W
$P_{th,amb}$	Heat flow rate to the ambient	W
$P_{th,f}$	Heat flow rate due to frictional power	W
$P_{th,L}$	Heat flow rate in the lubricant	W
Q	Lubricant flow rate	m ³ /s

Table 1 (continued)

Symbol	Designation	Unit
Q_1	Lubricant flow rate at the inlet to clearance gap	m ³ /s
Q_2	Lubricant flow rate at the outlet to clearance gap	m ³ /s
Q_3	Lubricant flow rate due to hydrodynamic pressure	m ³ /s
Q_3^*	Lubricant flow rate parameter due to hydrodynamic pressure	1
Q_p	Lubricant flow rate due to feed pressure	m ³ /s
Q_p^*	Lubricant flow rate parameter due to feed pressure	1
Rz_B	Average peak-to-valley height of bearing sliding surface	m
Rz_J	Average peak-to-valley height of shaft mating surface	m
Re	Reynolds number	1
So	Sommerfeld number	1
T_{amb}	Ambient temperature	°C
T_B	Bearing temperature	°C
$T_{B,0}$	Assumed initial bearing temperature	°C
$T_{B,1}$	Calculated bearing temperature resulting from iteration procedure	°C
T_{en}	Lubricant temperature at bearing entrance	°C
T_{ex}	Lubricant temperature at bearing exit	°C
$T_{ex,0}$	Assumed initial lubricant temperature at bearing exit	°C
$T_{ex,1}$	Calculated lubricant temperature at bearing exit	°C
T_J	Shaft temperature	°C
T_{lim}	Maximum permissible bearing temperature	°C
\bar{T}_L	Mean lubricant temperature	°C
U_B	Linear velocity (peripheral speed) of bearing	m/s
U_J	Linear velocity (peripheral speed) of shaft	m/s
V_a	Air ventilating velocity	m/s
x	Coordinate parallel to the sliding surface in the circumferential direction	m
y	Coordinate perpendicular to the sliding surface	m
z	Coordinate parallel to the sliding surface in the axial direction	m
$\alpha_{l,B}$	Linear heat expansion coefficient of the bearing	K ⁻¹
$\alpha_{l,J}$	Linear heat expansion coefficient of the shaft	K ⁻¹
β	Attitude angle (angular position of the shaft eccentricity related to the direction of load)	°
δ_J	Angle of misalignment of the shaft	rad
ε	Relative eccentricity	1
η	Dynamic viscosity of the lubricant	Pa·s
η_{eff}	Effective dynamic viscosity of the lubricant	Pa·s
ν	Kinematic viscosity of the lubricant	Pa·s
ξ	Coefficient of resistance to rotation in the loaded area of the lubricant film	1
ξ'	Coefficient of resistance to rotation in the unloaded area of the lubricant film	1

Table 1 (continued)

Symbol	Designation	Unit
ξ_G	Coefficient of resistance to rotation in the area of circumferential groove	1
ξ_P	Coefficient of resistance to rotation in the area of the pocket	1
ρ	Density of lubricant	kg/m ³
φ	Angular coordinate in the circumferential direction	rad
φ_1	Angular coordinate of pressure leading edge	rad
φ_2	Angular coordinate of pressure trailing edge	rad
ψ	Relative bearing clearance	1
$\bar{\psi}$	Mean relative bearing clearance	1
ψ_{eff}	Effective relative bearing clearance	1
ψ_{max}	Maximum relative bearing clearance	1
ψ_{min}	Minimum relative bearing clearance	1
ω_B	Angular velocity of bearing	s ⁻¹
ω_h	Hydrodynamic angular velocity	s ⁻¹
ω_J	Angular velocity of shaft	s ⁻¹
Ω	Angular span of bearing segment	°
Ω_G	Angular span of lubrication groove	°
Ω_P	Angular span of lubrication pocket	°

6.2 Frictional power loss

Friction in a hydrodynamic plain bearing due to viscous shear stress is given by the coefficient of friction $f = F_f/F$ and the derived non-dimensional characteristics of frictional power loss ξ and f/ψ_{eff}

$$\xi = \frac{F_f \psi_{\text{eff}}}{DB \eta_{\text{eff}} \omega_h} \quad (10)$$

$$\frac{f}{\psi_{\text{eff}}} = \frac{\xi}{So} \quad (11)$$

They are applied if the frictional power loss is encountered only in the loaded area of the lubricant film.

It is still necessary to calculate frictional power loss in both the loaded and unloaded areas then the values

$$f, F_f, \xi, \frac{f}{\psi_{\text{eff}}}$$

are substituted by:

$$f', F_f', \xi', \frac{f'}{\psi_{\text{eff}}}$$

in Formulae (10) and (11). This means that the whole of the clearance gap is filled with lubricant.

The values of f/ψ_{eff} and f'/ψ_{eff} for various values of ε , B/D , and Ω are given in ISO 7902-2. It also gives the approximation formulae, based on Reference [15], which are used to determine frictional power loss values in the bearings, taking account of the influence of lubricating pockets and grooves.

The frictional power in a bearing or the amount of heat generated is given by:

$$P_f = P_{th,f} = fF \frac{D}{2} \omega_h \quad (12)$$

$$P_f' = f'F \frac{D}{2} \omega_h \quad (13)$$

6.3 Lubricant flow rate

The lubricant fed to the bearing forms a film of lubricant separating the sliding surfaces. The pressure build-up in this film forces lubricant out of the ends of the bearing. This is the proportion Q of the lubricant flow rate, resulting from the build-up of hydrodynamic pressure.

$$Q_3 = D^3 \psi_{\text{eff}} \omega_h Q_3^* \quad (14)$$

where $Q_3^* = Q_3^*(\varepsilon, B/D, \Omega_1)$ is given in ISO 7902-2.

There is also a flow of lubricant in the peripheral direction through the narrowest clearance gap into the diverging, pressure-free gap. For increased loading and with a small lubrication gap clearance; however, this proportion of the lubricant flow is negligible.

The lubricant feed pressure, p_{en} , forces additional lubricant out of the ends of the plain bearing. This is the amount Q_p of the lubricant flow rate resulting from feed pressure:

$$Q_p = \frac{D^3 \psi_{\text{eff}}^3 p_{\text{en}}}{\eta_{\text{eff}}} Q_p^* \quad (15)$$

where $Q_p^* = Q_p^*(\varepsilon, B/D, \Omega)$ is given in ISO 7902-2.

6.3.1 Lubricant feed elements are lubrication holes, lubrication grooves, and lubrication pockets. The lubricant feed pressure, p_{en} , should be markedly less than the specific bearing load, \bar{p} , to avoid additional hydrostatic loads. Usually, p_{en} lies between 0,05 MPa and 0,2 MPa. The depth of the lubrication grooves and lubrication pockets is considerably greater than the bearing clearance.

6.3.2 Lubrication grooves are elements designed to distribute lubricant in the circumferential direction. The recesses machined into the sliding surface run circumferentially and are kept narrow in the axial direction. If lubrication grooves are located in the vicinity of pressure rise, the pressure distribution is split into two independent pressure “hills” and the load-carrying capacity is markedly reduced (see [Figure 3](#)). In this case, the calculation shall be carried out for half the load applied to each half bearing. However, because of the build-up of hydrodynamic pressure, Q_3 , only half of the lubricant flow rate shall be taken into account when balancing heat losses (see [6.4](#)), since the return into the lubrication groove plays no part in dissipating heat. It is more advantageous, for a full bearing, to arrange the lubrication groove in the unloaded part. The entire lubricant flow amount, Q_p , goes into the heat balance.

6.3.3 Lubrication pockets are elements for distributing the lubricant over the length of the bearing. The recesses machined into the sliding surface are oriented in the axial direction and should be as short as possible in the circumferential direction. Relative pocket lengths should be such shall $b_p / B < 0,7$. Although larger values increase the oil flow rate, the oil emerging over the narrow, restricting webs at the ends plays no part in dissipating heat. This is even more true if the end webs are penetrated axially. For full bearings ($\Omega = 360^\circ$), a lubrication pocket opposite to the direction of load as well as two lubrication pockets normal to the direction of loading are machined in. Since the lubricant flow rate, even in the unloaded part of the bearing, provides for the dissipation of frictional heat arising from shearing, the lubricating pockets shall be fully taken into account in the heat balance. For shell segments ($\Omega < 360^\circ$), the lubricant flow rate due to feed pressure through lubrication pockets at the inlet or outlet of the shell

segment makes practically no contribution to heat dissipation, since the lubrication pockets are scarcely restricted at the segment ends and the greater proportion of this lubricant flow emerges directly.

If the lubricant fills the loaded area of the bearing and there is no lubricant in the unloaded part, then the heat dissipation counts as lubricant flow rate in the loaded part only.

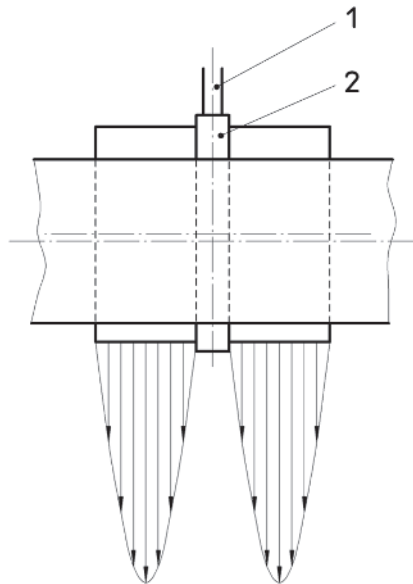

Key

- 1 lubrication hole
- 2 lubrication groove

Figure 3

The influence of the type and the arrangement of the lubricant feed elements on the lubricant flow rate are dealt with in ISO 7902-2.

The overall lubricant flow rate is given by:

$$Q = Q_3 \quad (16)$$

for lubricant filling only the loaded area of the bearing;

$$Q = Q_3 + Q_p \quad (17)$$

for lubricant filling the whole circular lubrication clearance gap including unloaded part, i.e. 2π .

6.4 Heat balance

The thermal condition of the plain bearing can be obtained from the heat balance. The heat flow, $P_{th,f}$, arising from frictional power in the bearing, P_f , is dissipated via the bearing housing to the environment and the lubricant emerging from the bearing. In practice, one or other of the two types of heat dissipation dominates. By neglecting the other, an additional safety margin is obtained during the design stage. The following assumptions can be made:

- a) Pressureless-lubricated bearings (for example ring lubrication) dissipate heat mainly through convection to the environment: $P_{th,f} = P_{th,amb}$
- b) Pressure-lubricated bearings dissipate heat mainly via the lubricant: $P_{th,f} = P_{th,L}$

6.4.1 Heat dissipation by convection

Heat dissipation by convection takes place by thermal conduction in the bearing housing and radiation and convection from the surface of the housing to the environment. The complex processes during the heat transfer can be summed up by:

$$P_{th,amb} = k_A A (T_B - T_{amb}) \quad (18)$$

where

$$k_A = 15 \text{ to } 20 \text{ W / (m}^2 \cdot \text{K)}$$

or, by ventilating the bearing housing with air at a velocity of $V_a > 1,2 \text{ m/s}$

$$k_A = 7 + 12 \sqrt{V_a} \quad (19)$$

(See References [3] and [14].)

Should the area of the heat-emitting surface, A , of the bearing housing not be known exactly, the following can be used as an approximation:

— for cylindrical housings

$$A = 2 \frac{\pi}{4} (D_H^2 - D^2) + \pi D_H B_H \quad (20)$$

— for pedestal bearings

$$A = \pi H \left(B_H + \frac{H}{2} \right) \quad (21)$$

— for bearings in the machine structure

$$A = (15 \text{ to } 20) DB \quad (22)$$

where

B_H is the length of the axial housing;

D_H is the length of the outside diameter of the housing;

H is the length of the total height of the pedestal bearing.

6.4.2 Heat dissipation via the lubricant

In the case of force-feed lubrication, heat dissipation is via the lubricant:

$$P_{th,L} = \rho c Q (T_{ex} - T_{en}) \quad (23)$$

For mineral lubricants, the volume-specific heat is given by:

$$\rho c = 1,8 \times 10^6 \text{ J / (m}^3 \cdot \text{K)} \quad (24)$$

From the heat balance, it follows that

$$P_{th,f} = P_{th,amb}$$

for pressureless-lubricated bearings and

$$P_{th,f} = P_{th,L}$$

for pressure-lubricated bearings.

This gives bearing temperature, T_B (see Reference [15]), and lubricant outlet temperature, T_{ex} (see Reference [15]). The effective film lubricant temperature with reference to the lubricant viscosity is

a) in the case of pure convection: $T_{eff} = T_B$

b) in the case of heat dissipation via the lubricant: $T_{eff} = \bar{T}_L = 0,5 (T_{en} + T_{ex})$

At high peripheral speed, it is possible to select, instead of these mean values, a temperature which lies nearer to the lubricant outlet temperature.

The values calculated for T_B and T_{ex} shall be checked for their permissibility by comparison with the permissible operational parameters, T_{lim} , given in ISO 7902-3.

In the sequence of calculations, at first only the operational data T_{amb} or T_{en} are known, but not the effective temperature, T_{eff} , which is required at the start of the calculation. The solution is obtained by first starting the calculation using an estimated temperature rise, i.e.

a) $T_{B,0} - T_{amb} = 20 \text{ K}$

b) $T_{ex,0} - T_{en} = 20 \text{ K}$

and the corresponding operating temperatures, T_{eff} . From the heat balance, corrected temperatures, $T_{B,1}$ or $T_{ex,1}$, are obtained, which, by averaging with the temperatures previously assumed ($T_{B,0}$ or $T_{ex,0}$), are iteratively improved until the difference between the values with index 0 and 1 becomes negligibly small, for example 2 K. The condition then attained corresponds to the steady condition. During the iterative steps, the influencing factors given in 6.7 shall be taken into account. As a rule, the iteration converges rapidly. It can also be replaced by graphical interpolation in which, for calculating $P_{th,f}$ and $P_{th,amb}$ or $P_{th,L}$, several temperature differences are assumed. If the heat flows $P_{th,amb} = f(T_B)$ or $P_{th,L} = f(T_{ex})$ are plotted, then the steady condition is given by the intersection of the two curves (see Figure A.1).

6.5 Minimum lubricant film thickness and specific bearing load

The clearance gap, h , in a circular cylindrical journal bearing with the shaft offset is a function given by:

$$h = 0,5D\psi_{eff} (1 + \varepsilon \cos \varphi) \quad (25)$$

starting with $\varphi = \varphi_1$, in the widest clearance gap (see Figure 1).

The minimum lubricant film thickness

$$h = 0,5D\psi_{eff} (1 - \varepsilon) \quad (26)$$

shall be compared with the permissible operational parameter, h_{lim} , specified in ISO 7902-3.

The specific bearing load:

$$\bar{p} = \frac{F}{DB} \quad (27)$$

shall be compared with the permissible operational parameter, p_{lim} , specified in ISO 7902-3.

6.6 Operational conditions

Should the plain bearing be operated under several, varying sets of operating conditions over lengthy periods, then they shall be checked for the most unfavourable \bar{p} , h_{\min} , and T_B . First, a decision shall be reached as to whether or not the bearing can be lubricated without pressure and whether or not the heat dissipation by convection suffices. The most unfavourable thermal case shall be investigated, which, as a rule, corresponds to an operating condition at high rotary frequency together with heavy loading. If, for pure convection, excessive bearing temperatures occur, which even by increasing the dimensions of the bearing or of the surface area of the housing to their greatest possible extent cannot be lowered to permissible values, then force-feed lubrication and oil cooling are necessary.

If an operating condition under high thermal loading (low dynamic lubricant viscosity) is followed directly by one with high specific bearing load and low rotary frequency, this new operating condition should be investigated while keeping the thermal condition from the preceding operating point.

The transition to mixed friction is due to contact of the roughness peaks of the shaft and bearing under the criteria for h_{\lim} specified in ISO 7902-3, whereby deformation is also to be taken into account. A transition eccentricity:

$$\varepsilon_u = 1 - \frac{h_{\lim}}{\frac{D}{2}\psi_{\text{eff}}} \quad (28)$$

and a transition Sommerfeld number:

$$So_u = \frac{F\psi_{\text{eff}}^2}{DB\eta_{\text{eff}}\omega_h} = f\left(\varepsilon_u, \frac{B}{D}, \Omega\right) \quad (29)$$

(see ISO 7902-2)

can be assigned to this value. Thus, the individual transition conditions (load, viscosity, and rotary speed) can be determined. The transition condition can be described by just three coexistent parameters. In order to be able to determine one of them, the two others have to be substituted in the manner appropriate to this condition. For rapid run-down of the machine, the thermal state corresponds mostly to the previous continuously driven operating condition of high thermal loading. If cooling is shut off immediately when the machine is switched off, this can result in an accumulation of heat in the bearing, so that a yet more unfavourable value has to be selected for h_{eff} . If the machine runs down slowly, lowering of the temperature of the lubricant or bearing is to be expected.

6.7 Further influencing factors

The calculation procedure applies to steady-state operation, in particular for loading that is constant in magnitude and direction and in which it is possible for the shaft and the bearing to rotate with uniform speed. The effective angular velocity is given by:

$$\omega_h = \omega_J + \omega_B \quad (30)$$

The calculation procedure, however, also applies for the case of a constant load which rotates at an angular velocity ω_F . In this case, the angular velocity is given by:

$$\omega_h = \omega_J + \omega_B - 2\omega_J \quad (31)$$

For an out-of-balance force rotating with the shaft ($\omega_F = \omega_J$), then:

$$\omega_h = -\omega_J + \omega_B \quad (32)$$

The absolute value of ω_h shall be used to calculate the Sommerfeld number. It shall be borne in mind that in the case where $\omega_h < 0$, the shaft eccentricity is at the angle $-\beta$ (see [Figure 4](#)).

NOTE All rotary motions and angular directions are positive with respect to the direction of shaft rotation.

The dynamic viscosity is strongly dependent on temperature. It is thus necessary to know the temperature dependence of the lubricant and its specification (see ISO 3448). The effective dynamic viscosity, η_{eff} , is determined by means of the effective lubricant film temperature, T_{eff} ; that is η_{eff} results from averaging temperatures T_{en} and T_{ex} and not from averaging the dynamic viscosities $\eta(T_{\text{en}})$ and $\eta(T_{\text{ex}})$.

The dynamic viscosity is also pressure-dependent, but to a lesser degree. For bearings in steady-state conditions and under the usual specific bearing loads, \bar{p} , the pressure dependence can, however, be neglected. This neglecting of pressure dependency represents an additional design factor of safety.

For non-Newtonian lubricants (intrinsically viscous oils, multi-range oils), reversible and irreversible fluctuations in viscosity occur as a function of the shear loading within the lubricant clearance gap and of the service life. These effects are investigated only for a few lubricants and are not taken into account in ISO 7902 [7].

The operation bearing clearance results from the fit and the thermal expansion behaviour of bearing and shaft. In the installed condition (20 °C), the relative bearing clearance is given by:

$$\psi_{\text{max}} = \frac{D_{\text{max}} - D_{J,\text{min}}}{D} \quad (33)$$

$$\psi_{\text{min}} = \frac{D_{\text{min}} - D_{J,\text{max}}}{D} \quad (34)$$

$$\bar{\psi} = 0,5 (\psi_{\text{max}} + \psi_{\text{min}}) \quad (35)$$

The deciding factor in the calculation is the effective relative bearing clearance, ψ_{eff} , at the effective lubricant film temperature, T_{eff} , which can be regarded (subject to the assumptions in 3.5) as the mean temperature of bearing and shaft. Insofar, as the coefficients of linear expansion of the shaft, $\alpha_{J,J}$, and of the bearing, $\alpha_{I,B}$, do not differ, the clearance when cold (20 °C) is equal to the clearance when hot (T_{eff}). Should shaft and bearing (bearing liner with housing) show different temperatures (T_J , T_B) due to external influences, then this shall be taken into account [see Formula (37)]. The linear expansion of the thin bearing layer can be neglected.

For coefficients of linear expansion which differ for shaft and bearing, the thermal change of the relative bearing clearance is given by:

$$\Delta\psi = (\alpha_{I,B} - \alpha_{I,J})(T_{\text{eff}} - 20\text{ }^{\circ}\text{C}) \quad (36)$$

$$\Delta\psi = \alpha_{I,B}(T_B - 20\text{ }^{\circ}\text{C}) - \alpha_{I,J}(T_S - 20\text{ }^{\circ}\text{C}) \quad (37)$$

$$\psi_{\text{eff}} = \bar{\psi} + \Delta\psi \quad (38)$$

Permissible operational values for the bearing clearance are given in ISO 7902-3.

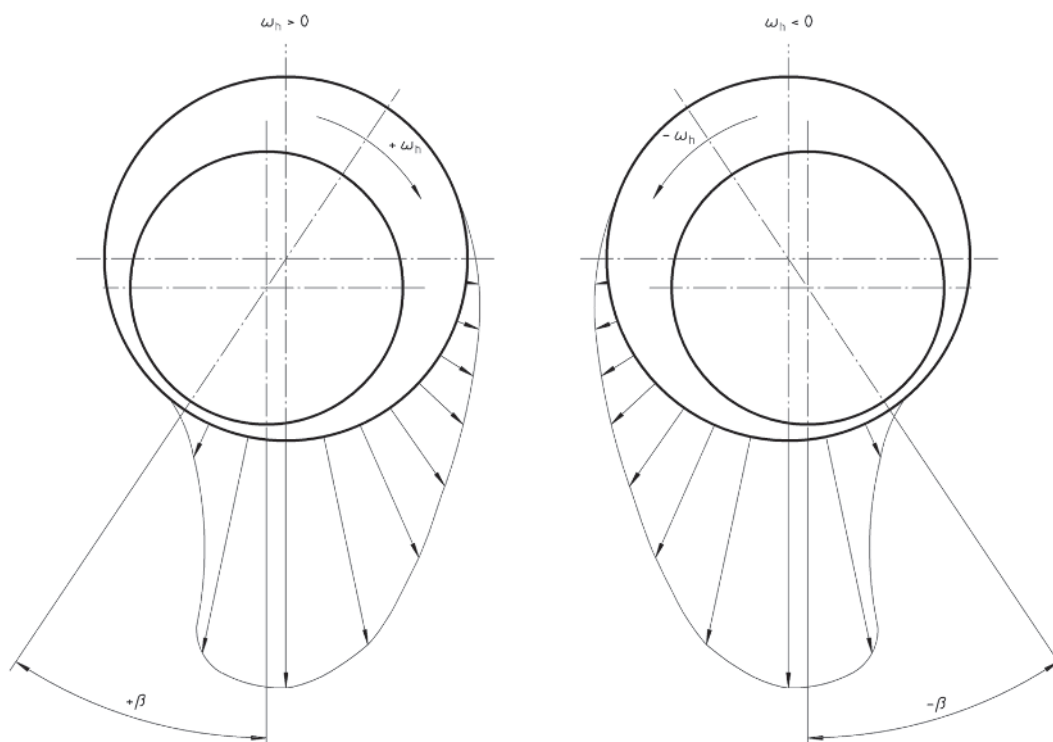

Figure 4

Annex A (normative)

Calculation examples

A.1 Example 1

A full bearing ($\Omega = 360^\circ$) with dimensions $D = 120$ mm and $B = 60$ mm, operated under a load $F = 36\,000$ N at a rotational frequency, N_J , $33,33\text{ s}^{-1}$ is to be investigated. It is assumed that this operating condition is the critical one for the heat balance. The bearing housing, of surface area $A = 0,3\text{ m}^2$, and the solid liner are made of aluminium alloy, the shaft being of steel. Oil is supplied via a hole with $d_L = 5$ mm, diametrically opposite the loaded area in the bearing liner, as shown in [Figure 1](#). The lubricant employed is an oil of viscosity grade ISO VG 100 (see ISO 3448-3). First of all, an investigation is to be made as to whether the bearing can perform without force-feed lubrication. In this case, heat dissipation occurs only by convection. The ambient temperature should be $T_{\text{amb}} = 40\text{ }^\circ\text{C}$ and the maximum permissible bearing temperature should be $T_{\text{lim}} = 70\text{ }^\circ\text{C}$.

Should T_{lim} be exceeded, then force-feed lubrication with external oil cooling is to be provided. In such a case, it is assumed that the lubricant is fed to the bearing at an overpressure of $p_{\text{en}} = 5 \times 10^5$ Pa and an oil inlet temperature of $T_{\text{en}} = 58\text{ }^\circ\text{C}$.

Dimensions and operational data

Bearing force	$F = 36\,000\text{ N}$
Rotational frequency of shaft	$N_J = 33,33\text{ s}^{-1}$
Rotational frequency of bearing	$N_B = 0\text{ s}^{-1}$
Angular span	$\Omega = 360^\circ$
Maximum bore of bearing	$D_{\text{max}} = 120,070 \times 10^{-3}\text{ m}$
Minimum bore of bearing	$D_{\text{min}} = 120,050 \times 10^{-3}\text{ m}$
Lubrication hole diameter	$d_L = 5 \times 10^{-3}\text{ m}$
Maximum diameter of shaft	$D_{J,\text{max}} = 119,950 \times 10^{-3}\text{ m}$
Minimum diameter of shaft	$D_{J,\text{min}} = 119,930 \times 10^{-3}\text{ m}$
Relative bearing length	$B/D = 0,5$
Mean peak-to-valley height of bearing	$Rz_B = 2 \times 10^{-6}\text{ m}$
Mean peak-to-valley height of shaft	$Rz_J = 1 \times 10^{-6}\text{ m}$
Coefficient of linear expansion of bearing	$\alpha_{l,B} = 23 \times 10^{-6}\text{ K}^{-1}$
Coefficient of linear expansion of shaft	$\alpha_{l,B} = 11 \times 10^{-6}\text{ K}^{-1}$
Lubricant oil	ISO VG 100

T_{eff} °C	$\eta_{\text{eff}}(T_{\text{eff}})$ Pa·s
40	0,098
50	0,057
60	0,037
70	0,025

Area of heat-emitting surface of the bearing housing	$A = 0,3 \text{ m}^2$
Heat transfer coefficient	$k_A = 20 \text{ W}/(\text{m}^2 \cdot \text{K})$
Ambient temperature	$T_{\text{amb}} = 40 \text{ °C}$
Lubricant inlet temperature for force-feed lubrication	$T_{\text{en}} = 58 \text{ °C}$
Lubrication feed overpressure for force-feed lubrication	$p_{\text{en}} = 5 \times 10^5 \text{ Pa}$
Specific heat by volume of the lubricant	$\rho c = 1,8 \times 10^6 \text{ J}/(\text{m}^3 \cdot \text{K})$

Limiting values

Maximum permissible specific bearing load	$\bar{p}_{\text{lim}} = 10 \times 10^6 \text{ Pa}$
Maximum permissible bearing temperature	$T_{\text{lim}} = 70 \text{ °C}$
Minimum permissible lubricant film thickness	$h_{\text{lim}} = 9 \times 10^{-6} \text{ m}$

Calculation based on the flow chart (see [Figure 1](#))

Check the laminar flow [see Formula (4)] at an assumed bearing temperature $T_{B,0} = 60 \text{ °C}$ and an assumed lubricant density $\rho = 900 \text{ kg}/\text{m}^3$:

$$Re = \frac{\pi \times 120 \times 10^{-3} \times 33,33 \times 1,48 \times 10^{-3} \times 120 \times 10^{-3} \times 900}{2 \times 0,037} = 27,14$$

$$< 41,3 \sqrt{\frac{120 \times 10^{-3}}{1,48 \times 10^{-3} \times 120 \times 10^{-3}}} = 1073,5 \tag{A.1}$$

$$Re = 27,14 < 1073,5$$

From Formula (27):

$$\bar{p} = \frac{36000}{120 \times 10^{-3} \times 60 \times 10^{-3}} = 5 \times 10^6 \text{ Pa} \tag{A.2}$$

The specific bearing \bar{p} is permissible, since $\bar{p} < \bar{p}_{\text{lim}}$

Heat dissipation by convection

Assumed initial bearing temperature

$$T_{B,0} = T_{\text{eff}} = 60 \text{ °C}$$

Effective dynamic viscosity of the lubricant at $T_{\text{eff}} = 60 \text{ °C}$ from the input parameters

$$\eta_{\text{eff}} = 0,037 \text{ Pa}\cdot\text{s}$$

Relative bearing clearances [see Formulae (33), (34), and (35)]

$$\psi_{\max} = \frac{(120,070 - 119,930) \times 10^{-3}}{120 \times 10^{-3}} = 1,1667 \times 10^{-3}$$

$$\psi_{\max} = \frac{(120,050 - 119,950) \times 10^{-3}}{120 \times 10^{-3}} = 0,833 \times 10^{-3} \quad (\text{A.3})$$

$$\bar{\psi} = 0,5(1,1667 + 0,833) \times 10^{-3} = 10^{-3}$$

Thermal change of the relative bearing clearance [see Formula (36)]

$$\Delta\psi = (23 - 11) \times 10^{-6} \times (60 - 20) = 0,48 \times 10^{-3} \quad (\text{A.4})$$

Effective relative bearing clearance [see Formula (38)]

$$\psi_{\text{eff}} = (1 + 0,48) \times 10^{-3} = 1,48 \times 10^{-3} \quad (\text{A.5})$$

Effective angular velocity [see Formula (30)]

— Angular velocity of the shaft:

$$\omega_J = 2 \times \pi \times N_J = 209,42 \text{ s}^{-1} \quad (\text{A.6})$$

— Angular velocity of the bearing:

$$\omega_B = 0 \quad (\text{A.7})$$

$$\omega_h = 209,42 + 0 = 209,42 \text{ s}^{-1} \quad (\text{A.8})$$

Sommerfeld number [see Formula (9)]:

$$S_o = \frac{36\,000 \times 1,48^2 \times 10^{-6}}{120 \times 10^{-3} \times 60 \times 10^{-3} \times 0,037 \times 209,42} = 1,408 \quad (\text{A.9})$$

Relative eccentricity (see ISO 7902-2):

$$\varepsilon = f\left(S_o, \frac{B}{D}, \Omega\right) = 0,773 \quad (\text{A.10})$$

Minimum lubricant film thickness [see Formula (26) and [Figure 1](#)]:

$$h_{\min} = 0,5 \times 120 \times 120^{-3} \times 1,48 \times 10^{-3} \times (1 - 0,773) = 20,2 \times 10^{-6} \text{ m} \quad (\text{A.11})$$

Specific coefficient of friction [see Formula (10) and ISO 7902-2]:

$$\frac{f'}{\psi_{\text{eff}}} = f\left(S_o, \frac{B}{D}, \Omega\right) = 3,68 \quad (\text{A.12})$$

Coefficient of friction:

$$f' = \frac{f'}{\psi_{\text{eff}}} \times \psi_{\text{eff}} = 3,68 \times 1,48 \times 10^{-3} = 5,45 \times 10^{-3} \quad (\text{A.13})$$

Heat flow due to frictional power in bearing [see Formula (12)]:

$$P_{\text{th},f} = 5,45 \times 10^{-3} \times 36\,000 \times \frac{120 \times 10^{-3}}{2} \times 209,42 = 2465,3 \text{ N} \cdot \text{m} / \text{s} = 2465,3 \text{ W} \quad (\text{A.14})$$

Heat flow rate via bearing housing and shaft to the environment [see Formula (18)]

$$P_{\text{th},\text{amb}} = 20 \times 0,3 \times (T_{\text{B},1} - 40)$$

From $P_{\text{th},f} = P_{\text{th},\text{amb}}$ it follows that

$$T_{\text{B},1} = \frac{2465,3}{20 \times 0,3} + 40 = 450,9 \text{ }^\circ\text{C} \quad (\text{A.15})$$

Since $T_{\text{B},1} > T_{\text{B},0}$, the assumption of a bearing temperature of $T_{\text{B},0} = 60 \text{ }^\circ\text{C}$ has to be corrected.

Improved assumption of the bearing temperature:

$$T_{\text{B},0}^i + 1 = T_{\text{B},0}^i + 0,2(T_{\text{B},1}^i - T_{\text{B},0}^i) = 60 + 0,2 \times (450,9 - 60) = 138,18$$

NOTE The assumption can be presented in alternative ways.

The further steps of the iteration are given in [Table A.1](#). In the fifth step of the calculation, the difference between the assumed bearing temperature, $T_{\text{B},0}$, and the calculated bearing temperature, $T_{\text{B},1}$, is less than $1 \text{ }^\circ\text{C}$. The bearing temperature, T_{B} , has thus been calculated to a sufficient degree of accuracy.

Since $T_{\text{B}} > T_{\text{lim}}$, heat dissipation by convection does not suffice. This bearing has therefore to be cooled by the lubricant (force-feed lubrication).

Table A.1

Variable	Unit	Step of the calculation				
		1	2	3	4	5
$T_{B0} = T_{eff}$	°C	60	138,2	135,5	134,4	133,8
η_{eff}	Pa·s	0,037	0,003 6	0,003 9	0,003 95	0,004
ψ_{eff}	1	$1,48 \times 10^{-3}$	$2,392 \times 10^{-3}$	$2,386 \times 10^{-3}$	$2,373 \times 10^{-3}$	$2,36 \times 10^{-3}$
S_o	1	1,408	37,95	34,85	34,04	33,24
ε	1	0,773	0,977	0,974	0,973 8	0,973
h_{min}	m	$20,2 \times 10^{-6}$	$3,3 \times 10^{-6}$	$3,72 \times 10^{-6}$	$3,73 \times 10^{-6}$	$3,82 \times 10^{-6}$
f/ψ_{eff}	1	3,68	0,47	0,501	0,508	0,52
P_f	W	2 465,3	508,55	540,7	545,3	558,18
T_B	°C	450,9	124,8	130,1	131,2	133
$T_{B,0}$	°C	138,2	135,5	134,4	138,8	

Heat dissipation via the lubricant (force-feed lubrication)

Assumed initial lubricant outlet temperature:

$$T_{\text{ex},0} = T_{\text{en}} + 20 \text{ °C} = 78 \text{ °C} \quad (\text{A.16})$$

Effective lubricant film temperature (see 6.4):

$$T_{\text{eff}} = 0,5 \times (58 + 78) = 68 \text{ °C} \quad (\text{A.17})$$

Effective dynamic viscosity of the lubricant at $T_{\text{eff}} = 68 \text{ °C}$ from the given parameters:

$$\eta_{\text{eff}} = 0,027 \text{ Pa} \cdot \text{s} \quad (\text{A.18})$$

Thermal modification of the relative bearing clearance [see Formula (36)]:

$$\Delta\psi = (23 - 11) \times 10^{-6} \times (68 - 20) = 0,576 \times 10^{-3} \quad (\text{A.19})$$

Effective relative bearing clearance [see Formula (38)]:

$$\psi_{\text{eff}} = (1 + 0,576) \times 10^{-3} = 1,576 \times 10^{-3} \quad (\text{A.20})$$

Sommerfeld number [see Formula (9)]:

$$So = \frac{36\,000 \times 1,576^2 \times 10^{-6}}{120 \times 10^{-3} \times 60 \times 10^{-3} \times 0,027 \times 209,42} = 2,196 \quad (\text{A.21})$$

Relative eccentricity (see ISO 7902-2):

$$\varepsilon = f\left(So, \frac{B}{D}, \Omega \right) = 0,825 \quad (\text{A.22})$$

Minimum lubricant film thickness [see Formula (26) and Figure 1]:

$$h_{\text{min}} = 0,5 \times 120 \times 10^{-3} \times 1,576 \times 10^{-3} (1 - 0,825) = 16,35 \times 10^{-6} \text{ m} \quad (\text{A.23})$$

Specific coefficient of friction [see Formula (11) and ISO 7902-2]:

$$\frac{f'}{\psi_{\text{eff}}} = \frac{f'}{\psi_{\text{eff}}}\left(So, \frac{B}{D}, \Omega \right) = 2,78 \quad (\text{A.24})$$

Coefficient of friction:

$$f' = \frac{f'}{\psi_{\text{eff}}} \times \psi_{\text{eff}} = 2,78 \times 1,576 \times 10^{-3} = 4,881 \times 10^{-3} \quad (\text{A.25})$$

Heat flow rate due to frictional power in bearing [see Formula (12)]:

$$P_{\text{th},f} = 4,881 \times 10^{-3} \times 36\,000 \times \frac{120 \times 10^{-3}}{2} \times 209,42 = 1981,7 \text{ N} \cdot \text{m} / \text{s} = 1981,7 \text{ W} \quad (\text{A.26})$$

$$Q_3 = 120^3 \times 10^{-3} \times 1,576 \times 10^{-3} \times 209,42 \times 0,0968 = 55,21 \times 10^{-6} \text{ m}^3 / \text{s} \quad (\text{A.27})$$

Lubricant flow rate due to feed pressure [see Formula (10) of ISO 7902-2:1998]:

$$q_L = 1,204 + 0,368 \times \frac{5}{60} - 1,046 \times \left(\frac{5}{60}\right)^2 + 1,942 \times \left(\frac{5}{60}\right)^3 = 1,228 \quad (\text{A.28})$$

$$Q_p^* = \frac{\pi}{48} \times \frac{(1 + 0,825)^3}{\ln\left(\frac{60}{5}\right) \times 1,228} = 0,1304 \quad (\text{A.29})$$

$$Q_p = \frac{120^3 \times 10^{-9} \times 1,576^3 \times 10^{-9} \times 5 \times 10^5}{0,027} \times 0,1304 = 16,33 \times 10^{-6} \text{ m}^3 / \text{s} \quad (\text{A.30})$$

Lubricant flow rate [see Formula (17)]:

$$Q = (55,21 + 16,33) \times 10^{-6} = 71,54 \times 10^{-6} \text{ m}^3 / \text{s} \quad (\text{A.31})$$

Heat flow rate via the lubricant [see Formula (23)]:

$$P_{th,L} = 1,8 \times 10^6 \times 71,54 \times 10^{-6} \times (T_{ex} - 58) \quad (\text{A.32})$$

Since $P_{th,f} = P_{th,L}$

$$T_{ex,1} = \frac{1981,7}{1,8 \times 10^6 \times 71,54 \times 10^{-6}} + 58 = 73,4 \text{ } ^\circ\text{C} \quad (\text{A.33})$$

Since $T_{ex,1} < T_{ex,0}$, the assumption of a lubricant outlet temperature of $T_{ex,0} = 78 \text{ } ^\circ\text{C}$ has to be corrected.

Improved assumption of the lubricant outlet temperature:

$$T_{ex,0} = 0,5 \times (78 + 73,4) = 75,7 \text{ } ^\circ\text{C} \quad (\text{A.34})$$

The further steps of the iteration are given in [Table A.2](#).

Table A.2

Variable	Unit	Step of the calculation		
		1	2	3
T_{en}	$^\circ\text{C}$	58	58	58
$T_{ex,0}$	$^\circ\text{C}$	78	75,7	74,9
T_{eff}	$^\circ\text{C}$	68	66,85	66,45
η_{eff}	Pa·s	0,027 1	0,028 3	0,028 7
ψ_{eff}	1	$1,576 \times 10^{-3}$	$1,562 \times 10^{-3}$	$1,557 \times 10^{-3}$
So	1	2,196	2,057	2,023
ε	1	0,825 4	0,824 6	0,818
h_{min}	m	$16,55 \times 10^{-6}$	$16,87 \times 10^{-6}$	17×10^{-6}
f/ψ_{eff}	1	2,78	2,84	2,9
P_f	W	1 981,7	2 006 × 65	2 038,96
Q_3	m^3/s	$55,21 \times 10^{-6}$	$54,49 \times 10^{-6}$	$54,09 \times 10^{-6}$

Table A.2

Variable	Unit	Step of the calculation		
		1	2	3
Q_p	m ³ /s	$16,33 \times 10^{-6}$	$15,04 \times 10^{-6}$	$14,64 \times 10^{-6}$
Q	m ³ /s	$71,54 \times 10^{-6}$	$69,53 \times 10^{-6}$	$68,73 \times 10^{-6}$
$T_{ex,1}$	°C	73,4	74	74,5
$T_{ex,0}$	°C	75,7	74,9	

In the third step of the calculation, the difference between the assumed initial lubricant outlet temperature, $T_{ex,0}$, and the calculated lubricant outlet temperature, $T_{ex,1}$, is smaller than 1 °C. The lubricant outlet temperature, T_{ex} , has therefore been calculated to a sufficient degree of accuracy.

Since $T_{ex} < T_{lim}$, the lubricant outlet temperature is permissible.

Since $h_{min} > h_{lim}$, the minimum lubricant film thickness is permissible.

Instead of the iteration calculation, it is possible to use graphical interpolation. This is done by performing the calculation for a series of assumed temperatures, T_B or T_{ex} , expected (which cover the range of the expected solution).

In [Table A.3](#), all intermediate results for the case of heat dissipation via the lubricant (force-feed lubrication) are given. The fourth step of the calculation gives the same values as the graphical solution shown in [Figure A.1](#).

Table A.3

Variable	Unit	Step of the calculation			
		1	2	3	4
T_{en}	°C	58	58	58	58
T_{ex}	°C	62	82	102	74,87
T_{eff}	°C	60	70	80	66,44
η_{eff}	Pa·s	0,037	0,025	0,018	0,028 7
ψ_{eff}	1	$1,48 \times 10^{-3}$	$1,6 \times 10^{-3}$	$1,72 \times 10^{-3}$	$1,557 \times 10^{-3}$
So	1	1,408	2,429	3,934	2,023
ε	1	0,771	0,838 3	0,880 1	0,818
h_{min}	m	$20,34 \times 10^{-6}$	$15,52 \times 10^{-6}$	$12,37 \times 10^{-6}$	17×10^{-6}
f'/ψ_{eff}	1	3,65	2,572	1,89	2,895
P_f	W	2 443,58	1 861,5	1 470,49	2 038,96
Q	m ³ /s	$57,54 \times 10^{-6}$	$75,46 \times 10^{-6}$	$99,05 \times 10^{-6}$	$68,73 \times 10^{-6}$
P_Q	W	414,2	3 259,87	7 844,76	2 087,06

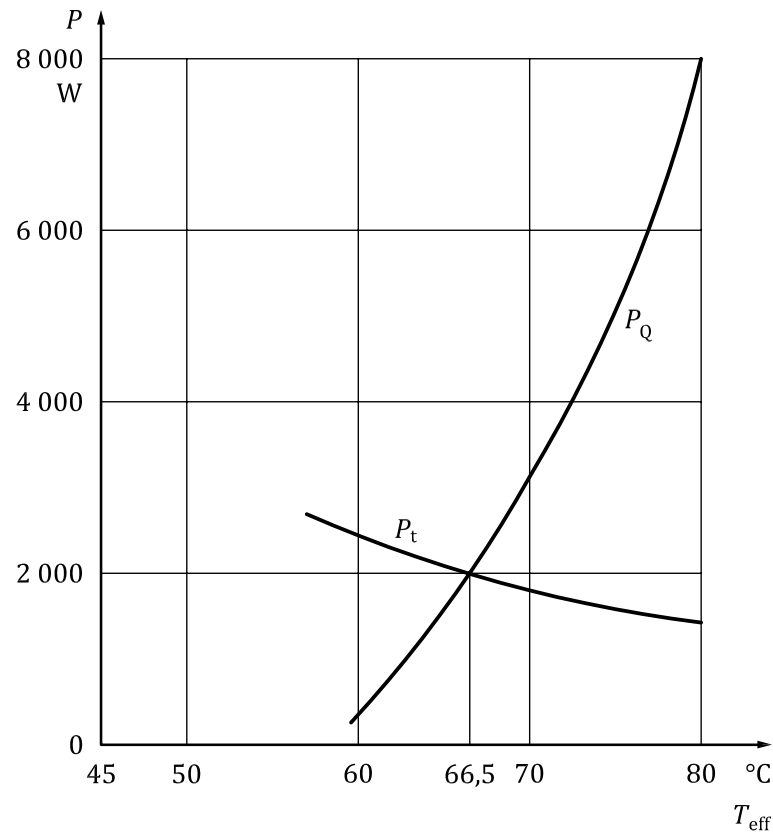

Figure A.1

A.2 Example 2

A partial bearing with dimensions $D = 1\,010$ mm and $B = 758$ mm ($\Omega = 150^\circ$) lubricated via a lubrication pocket, as shown in [Figure A.2](#), with slight overpressure. According to [6.3](#), the oil flow rate Q_p plays no part in the heat balance. Heat dissipation is thus due to the lubricant flow rate, Q_3 , alone, as a result of generation of internal pressure. The oil inlet temperature is $T_{en} = 24$ °C. There is no difference in the thermal expansion between shaft, bearing liner, and bearing housing.

Dimensions and operational data

Bearing force	$F = 10^6$ N
Rotational frequency of shaft	$N_j = 1,428\,3$ s ⁻¹
Angular velocity of shaft	$\omega_j = \omega_h = 8,974$ s ⁻¹
Angular span	$\Omega = 150^\circ$
Bearing bore	$D = 1\,010 \times 10^{-3}$ m
Mean relative bearing clearance	$\bar{\psi} = 10^{-3}$
Thermal modification of the relative bearing clearance	$\Delta\psi = 0$
Relative bearing length	$B/D = 0,75$

Lubricant oil

ISO VG 46

T_{eff} °C	$\eta_{\text{eff}}(T_{\text{eff}})$ Pa·s
20	0,132 4
30	0,072 1
40	0,043

Lubricant inlet temperature for force-feed lubrication

$$T_{\text{en}} = 24 \text{ °C}$$

Specific heat by volume of the lubricant

$$\rho c = 1,8 \times 10^6 \text{ J}/(\text{m}^3 \cdot \text{K})$$

Limiting values

Maximum permissible specific bearing load

$$\bar{p}_{\text{lim}} = 10 \times 10^6 \text{ Pa}$$

Maximum permissible bearing temperature

$$T_{\text{lim}} = 70 \text{ °C}$$

Minimum permissible lubrication film thickness

$$h_{\text{lim}} = 9 \times 10^{-6} \text{ m}$$

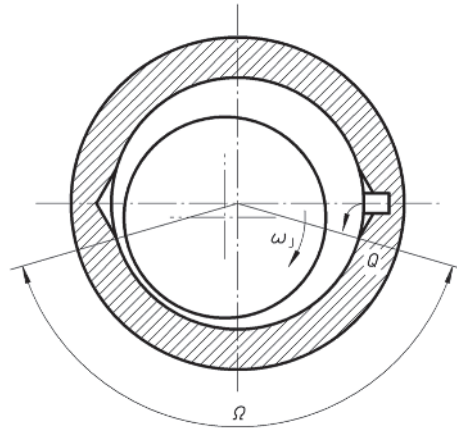

Figure A.2

Calculation based on the flow chart (see [Figure 4](#))

Check the laminar flow [see Formula (4)] at an assumed effective lubricant film temperature $T_{\text{eff}} = 40 \text{ °C}$ and an assumed lubricant density $\rho = 900 \text{ kg}/\text{m}^3$:

$$Re = \frac{\pi \times 1\,010 \times 10^{-3} \times 1,428\,3 \times 10^{-3} \times 1\,010 \times 10^{-3} \times 900}{2 \times 0,043} = 47,9$$

$$< 41,3 \sqrt{\frac{10^{-3}}{1}} = 1\,306 \tag{A.35}$$

$$Re = 47,9 < 1\,306$$

Flow is laminar. Thus, ISO 7902 is applicable in this case.

From Formula (27):

$$\bar{p} = \frac{10^6}{785 \times 10^{-3} \times 1\,010 \times 10^{-3}} = 1,306 \times 10^6 \text{ Pa} \tag{A.36}$$

The specific bearing load \bar{p} is permissible, since $\bar{p} < \bar{p}_{\text{lim}}$

Heat dissipation is via the lubricant.

[Table A.4](#) gives the intermediate results in the individual steps of the calculation. In the fourth step of the calculation, the difference between the assumed initial lubricant outlet temperature, $T_{ex,0}$, and the calculated outlet temperature, $T_{ex,1}$, is less than 1 °C. The lubricant outlet temperature, T_{ex} , has therefore been calculated to a sufficient degree of accuracy.

Since $T_{ex} < T_{lim}$, the lubricant outlet temperature is permissible. Since $h_{min} > h_{lim}$, the minimum lubricant film thickness is permissible

Table A.4

Variable	Unit	Step of the calculation			
		1	2	3	4
T_{en}	°C	24	24	24	24
$T_{ex,0}$	°C	44	38,5	36,2	35,1
T_{eff}	°C	34	31,3	30,1	29,55
η_{eff}	Pa·s	0,058	0,07	0,074	0,077
So	1	2,507	2,079	1,967	1,89
ε	1	0,798	0,767	0,758	0,75
h_{min}	m	$102,01 \times 10^{-6}$	$117,67 \times 10^{-6}$	$122,21 \times 10^{-6}$	$126,25 \times 10^{-6}$
f'/ψ_{eff}	1	1,65	1,822	1,87	1,92
P_f	W	7 477,6	8 248	8 338,6	8 701,2
Q_3	m ³ /s	$46,04 \times 10^{-5}$	$46,60 \times 10^{-5}$	$46,69 \times 10^{-5}$	$46,88 \times 10^{-5}$
$T_{ex,1}$	°C	33	33,83	34,08	34,31
$T_{ex,0}$	°C	38,5	36,2	35,1	

A.3 Example 3

A partial bearing with angular span $\Omega = 150^\circ$ is to be investigated; the lubricant is supplied to the loaded area of the bearing under overpressure via the upper half, as shown in [Figure A.3](#).

The upper half has a circumferential groove. Two lubricating pockets are located at the joint face at $\pm 90^\circ$ to the application of the load; one of the pockets is a feeding one.

Heat is dissipated via the lubricant and, according to [6.4](#), overall lubricant flow rate is to be calculated from Formulae (16) and (17). There is no difference in expansion between shaft, bearing, and bearing housing.

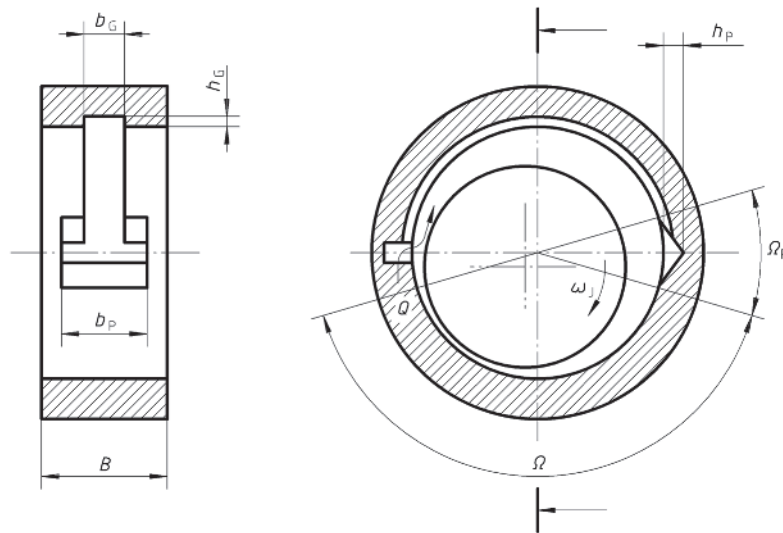

Figure A.3

Dimensions and operational data

Bearing force	$F = 18\,000\text{ N}$
Rotational frequency of shaft	$N_J = 25\text{ s}^{-1}$
Angular velocity of shaft	$\omega_J = \omega_h = 157\text{ s}^{-1}$
Angular span	$\Omega = 150^\circ$
Bearing bore	$D = 200 \times 10^{-3}\text{ m}$
Mean relative bearing clearance	$\bar{\psi} = 2 \times 10^3$
Thermal modification of the relative bearing clearance	$\Delta\psi = 0$
Relative bearing length	$B/D = 0,5$
Width of a 180° lubricating groove	$b_G = 30 \times 10^{-3}\text{ m}$
Depth of a lubricating groove	$h_G = 2,5 \times 10^{-3}\text{ m}$
Width of the lubricating pocket	$b_P = 60 \times 10^{-3}\text{ m}$
Depth of the lubricating pocket	$h_P = 2,5 \times 10^{-3}\text{ m}$
Lubricant oil	ISO VG 32

T_{eff} °C	$\eta_{\text{eff}}(T_{\text{eff}})$ Pa·s
40	0,031
50	0,022
60	0,014
70	0,009 4

Lubricant inlet temperature for force-feed lubrication	$T_{\text{en}} = 40\text{ °C}$
Lubricant feed overpressure for force-feed lubrication	$p_{\text{en}} = 0,5 \times 10^5\text{ Pa}$

Specific heat by volume of the lubricant

$$\rho c = 1,8 \times 10^{-6} \text{ J}/(\text{kg}\cdot\text{K})$$

Limiting values

Maximum permissible specific bearing load

$$\bar{p}_{\text{lim}} = 10 \times 10^6 \text{ Pa}$$

Maximum permissible bearing temperature

$$T_{\text{lim}} = 80 \text{ }^\circ\text{C}$$

Minimum permissible lubrication film thickness

$$h_{\text{lim}} = 20 \times 10^{-6} \text{ m}$$

Calculation based on the flow chart (see [Figure 4](#))

Check the laminar flow [see Formula (4)] at an assumed bearing temperature $T_{B,0} = 60 \text{ }^\circ\text{C}$ and an assumed lubricant density $\rho = 900 \text{ kg}/\text{m}^3$:

$$Re = \frac{\pi \times 200 \times 10^{-3} \times 25 \times 2 \times 10^{-3} \times 200 \times 10^{-3} \times 900}{2 \times 0,014} = 201,96$$

$$< 41,3 \sqrt{\frac{200 \times 10^{-3}}{2 \times 10^{-3} \times 200 \times 10^{-3}}} = 923,5 \tag{A.37}$$

$$Re = 201,96 < 923,5$$

Flow is laminar. Thus, ISO 7902 is applicable in this case.

From Formula (27):

$$\bar{p} = \frac{18\,000}{0,5 \times 200 \times 10^{-3} \times 200 \times 10^{-3}} = 0,9 \times 10^6 \text{ Pa} \tag{A.38}$$

The specific bearing load \bar{p} is permissible, since $\bar{p} < \bar{p}_{\text{lim}}$

Heat dissipation is via the lubricant. [Table A.5](#) gives the intermediate results in the various steps of the calculation.

Table A.5

Variable	Unit	Step of the calculation			
		1	2	3	4
T_{en}	$^\circ\text{C}$	40	40	40	40
$T_{\text{ex},0}$	$^\circ\text{C}$	60	52,1	48,6	47,3
T_{eff}	$^\circ\text{C}$	50	46,1	44,3	43,7
η_{eff}	$\text{Pa}\cdot\text{s}$	0,022	0,024	0,027 5	0,028
S_o	1	1,042	0,955 4	0,833 8	0,818 9
ϵ	1	0,734	0,725	0,7	0,698
h_{min}	m	$53,2 \times 10^{-6}$	55×10^{-6}	60×10^{-6}	$60,4 \times 10^{-6}$
f/ψ_{eff}	1	4,6	4,8	5,4	5,45
P_f	W	1 966,3	2 229	2 519,9	2 535,6
Q_3	m^3/s	$109,27 \times 10^{-6}$	$109,02 \times 10^{-6}$	$108,52 \times 10^{-6}$	$108,5 \times 10^{-6}$
Q_p	m^3/s	$153,72 \times 10^{-6}$	$139,84 \times 10^{-6}$	$119,49 \times 10^{-6}$	$117,15 \times 10^{-6}$
Q	m^3/s	$262,99 \times 10^{-6}$	$248,86 \times 10^{-6}$	$228,01 \times 10^{-6}$	$225,65 \times 10^{-6}$
$T_{\text{ex},1}$	$^\circ\text{C}$	44,2	45	46,1	46,3
$T_{\text{ex},0}$	$^\circ\text{C}$	52,1	48,6	47,6	

The specific feature of this calculation is the determination of frictional power and lubricant flow rate based on the flow in the lubricating pockets and grooves. The first step of the calculation is given as an example.

Frictional power in the lubricating pockets and grooves (see ISO 7902-2):

$$\xi_P = 2 \times 0,5 \times \frac{\pi}{6} \left[4 + 0,001 2 \left(\frac{900 \times 157 \times 2,5 \times 10^{-3} \times 200 \times 10^{-3}}{2 \times 0,022} \right) 0,94 \right] = 2,74 \quad (\text{A.39})$$

$$\xi_G = 0,5 \times \pi \left[4 + 0,001 2 \left(\frac{900 \times 157 \times 2,5 \times 10^{-3} \times 200 \times 10^{-3}}{2 \times 0,022} \right) 0,94 \right] = 8,22 \quad (\text{A.40})$$

Friction force in the whole lubricant film:

$$F' = \frac{0,022 \times 157 \times 100 \times 10^{-3} \times 200 \times 10^{-3}}{2 \times 10^{-3}} \left[1,042 \times 4,6 - \frac{60 \times 10^{-3}}{100 \times 10^{-3}} \left(\frac{\pi}{3 \times 2 \sqrt{1 - 0,734^2}} - \frac{2 \times 10^{-3} \times 200 \times 10^{-3}}{2 \times 2,5 \times 10^{-3}} 2,74 \right) - \frac{30 \times 10^{-3}}{100 \times 10^{-3}} \left(\frac{\pi}{2 \sqrt{1 - 0,734^2}} - \frac{2 \times 10^{-3} \times 200 \times 10^{-3}}{2 \times 2,5 \times 10^{-3}} 8,22 \right) \right] \quad (\text{A.41})$$

Heat flow rate due to frictional power in bearing:

$$P_{th,f} = 125,24 \times \frac{200 \times 10^{-3}}{2} \times 157 = 1966,3 \text{ N} \cdot \text{m} / \text{s} = 1966,3 \text{ W} \quad (\text{A.42})$$

Lubricant flow rate due to generation of internal pressure [see Formula (14)]:

$$Q_3 = 200^3 \times 10^{-9} \times 2 \times 10^{-3} \times 157 \times 0,043 5 = 109,27 \times 10^{-6} \text{ m}^3 / \text{s} \quad (\text{A.43})$$

Lubricant flow rate due to feed pressure [see Formulae (15) and (16) of ISO 7902-2:1998] is the sum of flow rates from lubricating pockets and grooves:

$$Q_p = 1,188 + 1,582 \left(\frac{60 \times 10^{-3}}{100 \times 10^{-3}} \right) - 2,585 \left(\frac{60 \times 10^{-3}}{100 \times 10^{-3}} \right)^2 + 5,563 \left(\frac{60 \times 10^{-3}}{100 \times 10^{-3}} \right)^3 = 2,408 2 \quad (\text{A.44})$$

$$Q_p^* = \frac{\pi}{6} \frac{1}{\ln \left(\frac{100 \times 10^{-3}}{60 \times 10^{-3}} \right)} \frac{2,408 2}{2,408 2} + \frac{1}{48} \frac{\pi (1 + 1 \times 5 \times 0,734^2) + 6 \times 0,734 + 1 \times 33 \times 0,734^3}{\frac{100 \times 10^{-3} - 30 \times 10^{-3}}{200 \times 10^{-3}}} = 1,056 8 \quad (\text{A.45})$$

$$Q_p = \frac{200^3 \times 10^{-9} \times 2^3 \times 10^{-9} \times 0,5 \times 10^5}{0,022} \cdot 1,0568 = 153,72 \times 10^{-6} \text{ m}^3 / \text{s} \quad (\text{A.46})$$

Lubricant flow rate [see Formulae (16) and (17)]:

$$Q = (109,27 + 153,72) \times 10^{-6} = 262,99 \times 10^{-6} \text{ m}^3 / \text{s} \quad (\text{A.47})$$

Heat dissipation via lubricant [see Formula (23)]:

$$P_{th,L} = 1,8 \times 10^6 \times 262,99 \times 10^6 (T_{2,1} - 40) \quad (\text{A.48})$$

$P_{th,f} = P_{th,L}$ yields:

$$T_{ex,1} = \frac{2\,222,1}{1,8 \times 10^6 \times 262,99 \times 10^{-6}} + 40 = 44,7 \text{ } ^\circ\text{C} \quad (\text{A.49})$$

Table A.6 gives the results of the calculation, taking account of the lubricant flow rate via a lubricating pocket. As before, it is assumed that lubricant fills both the loaded and unloaded areas of the lubricating clearance.

In this case, in the first step of the calculation, lubricant flow rate from the pocket is

$$Q_p = 2,408\,2$$

$$Q_p^* = \frac{\pi}{6} \frac{1}{\ln\left(\frac{100 \times 10^{-3}}{60 \times 10^{-3}}\right)} \times 2,408\,2 = 0,4254 \quad (\text{A.50})$$

$$Q_p = \frac{200^3 \times 10^{-9} \times 2^3 \times 10^{-9} \times 0,5 \times 10^5}{0,022} \cdot 0,4254 = 61,88 \times 10^{-6} \text{ m}^3 / \text{s}$$

Table A.6

Variable	Unit	Step of the calculation			
		1	2	3	4
T_{en}	$^\circ\text{C}$	40	40	40	40
$T_{ex,0}$	$^\circ\text{C}$	60	53,9	51,1	50
T_{eff}	$^\circ\text{C}$	50	47	45,5	45
η_{eff}	Pa·s	0,022	0,023 5	0,025 2	0,026 3
S_o	1	1,042	0,957 7	0,909 9	0,881 9
ε	1	0,734	0,727	0,717	0,71
h_{min}	m	$53,2 \times 10^{-6}$	$54,6 \times 10^{-6}$	$56,6 \times 10^{-6}$	59×10^{-6}
f'/ψ_{eff}	1	4,6	4,75	5	5,18
P_f	W	2 419,7	2 494,6	2 625,8	2 722, 9
Q_3	m^3/s	$109,27 \times 10^{-6}$	$109,15 \times 10^{-6}$	$109,02 \times 10^{-6}$	$108,77 \times 10^{-6}$
Q_p	m^3/s	$61,88 \times 10^{-6}$	$57,93 \times 10^{-6}$	$54,02 \times 10^{-6}$	$49,86 \times 10^{-6}$
Q	m^3/s	$171,15 \times 10^{-6}$	$167,08 \times 10^{-6}$	$163,04 \times 10^{-6}$	$158,63 \times 10^{-6}$
$T_{ex,1}$	$^\circ\text{C}$	47,9	48,3	48,9	49,5
$T_{ex,0}$	$^\circ\text{C}$	53,9	51,1	50	

Bibliography

- [1] REYNOLDS O. On the theory of lubrication and its application to Mr. Beauchamp Tower's experiments including an experimental determination of the viscosity of olive oil. *Phil. Trans.* (1866), **177**, pp. 157-234. *Ostwalds Klassiker der exakten Wissenschaften, Leipzig*. Nr. 218, Leipzig, 1927
- [2] SOMMERFELD A. Zur hydrodynamischen Theorie der Schmiermittelreibung. *Zeitschrift für Mathematik und Physik*. 1904, **40** pp. 97-155
- [3] VOGELPOHL G. Beiträge zur Gleitlagerberechnung. *VDI-Forschungsheft*, Nr. 386, Düsseldorf, 1954
- [4] SASSENFELD. H. and WALTHER A. Gleitlagerberechnung. *VDI-Forschungsheft*, Nr. 441, Düsseldorf, 1954.
- [5] RAIMONDI A.A., & BOYD J. A solution for the finite journal bearing and its application to analysis and design *Trans. A.S.L.E* (1958), **1**, part 1, pp. 159-174; part 2, pp. 175-194; part 3, pp. 194-209
- [6] BUTENSCHON H.-J. *Das hydrodynamische zylindrische Gleitlager endlicher Breite unter instationärer Belastung*. Dissertation, TU Karlsruhe, 1976
- [7] WISSUSSEK. D. *Der Einfluß reversibler und irreversibler Viskositätsänderungen auf das Verhalten hydrodynamischer stationär belasteter Gleitlager*. Dissertation, TU Hannover, 1975
- [8] LANG O.R., & STEINHILPERS W. *Gleitlager, Konstruktionsbücher*, **31**, Springer Verlag Berlin, Heidelberg, New York, 1978
- [9] DILLENKOFER. H. *Einfluß der Lage der Ölzuführungsstelle auf das Betriebsverhalten stationär belasteter zylindrischer Gleitlager endlicher Breite*. Dissertation, Universität Stuttgart, 1975
- [10] HOPPE. J. *Einfluß der Oberflächenwelligkeit von Lagerzapfen auf das Verhalten hydrodynamisch geschmierter Radialgleitlager*. Dissertation, Universität Karlsruhe, 1981
- [11] PINKUS. C. and STERNLICHT B. *Theory of hydrodynamic lubrication*. McGraw-Hill Book Company, Inc, New York, Toronto, London, 1961
- [12] KVINITSKY B. KIRKATCH N.F., & POLTAVSKY Y.D The solution of Reynolds' equation under natural boundary conditions for hydrodynamic journal bearings, *Wear*, **37**, 2, pp. 217-231, Elsevier Sequoia, Lausanne, 1978
- [13] KVINITSKY B.I. and KIRKATCH N.F. *Calculation of plain journal bearings (reference book)*. Mashinostroenic, Moscow, 1979
- [14] KOROVCHINSKY. M.V. *Theoretical basis for plain bearings operation*. Mashgiz, Moscow, 1959
- [15] CONSTANTINESCU V. Basic Relationships in Turbulent Lubrication and their Extension to include Thermal Effects. *Transactions of the ASME*, Series, F, No. 2, **95**, 1973, pp. 35-43
- [16] ISO 4378-5, *Plain bearings — Terms, definitions, classification and symbols — Part 5: Application of symbols*

